

# ASCO™ Solenoid Valves

Pilot Operated, Hung Diaphragm, 3/8" to 1 1/2"

## Features and Benefits

- Two way shut-off valves for the control air, inert gas, water, oil and other gases/liquids compatible with the sealing material used
- Valves do not require a minimum operating pressure
- All products are covered by Pressure Equipment Directive 2014/68/EU and are suitable for group 1 and 2 fluids
- The solenoid valves satisfy all relevant EU directives

## General

**Differential pressure** See «SPECIFICATIONS» [1 bar = 100 kPa]  
**Maximum viscosity** 65 cSt (mm<sup>2</sup>/s)  
**Response time** 15 - 120 ms

Fluids (*)	Temperature range (TS)	Seal materials (*)
air, inert gas, water, oil	-20°C to +85°C	NBR (nitrile)

## Materials of components in contact with fluid

(\*) Ensure that compatibility of materials in contact with fluids is verified.

	Brass body	Stainless steel body
<b>Body</b>	Brass	AISI 304 SS (AISI 316 SS on request)
<b>Core tube</b>	Stainless steel	Stainless steel
<b>Core and plugnut</b>	Stainless steel	Stainless steel
<b>Springs</b>	Stainless steel	Stainless steel
<b>Seat</b>	Brass	Stainless steel
<b>Seals, diaphragm and disc</b>	NBR	NBR
<b>Disc holder (NO function)</b>	PA	PA
<b>Shading coil</b>	Copper	Silver

## Electrical characteristics

**Coil insulation class** F or H  
**Connector** Spade plug (cable Ø 6-10 mm)  
**Connector specification** ISO 4400 / EN 175301-803, form A  
**Electrical safety** IEC 335  
**Electrical enclosure protection** Moulded IP65 (EN 60529)  
**Standard voltages** DC (=): 24V - 48V  
 AC (~): 24V - 48V - 115V - 230V / 50 Hz  
 (Other voltages and 60 Hz on request)

Prefix option	Power ratings				Operator ambient temperature range (TS) <sup>(1)</sup> (°C)	Replacement coil		Type <sup>(2)</sup>
	Inrush ~ (VA)	Holding ~ (VA) (W)		= (W)		~ 230 V/50 Hz	= 24 V DC	
		(VA)	(W)					
SC	55	23	10.5	-	-20 to +75	400425-117	-	01
	78	35	16.7	-	-20 to +50	400425-217	-	01
	110	33.6	15.4	12/16.8	-20 to +75	400525-117	400625-142	02
	240	43	20	16.8/23	-20 to +50	400525-217	400625-242	02

<sup>(1)</sup> 3/8" up to 1" max. operator ambient temperature range (TS) 60°C.

<sup>(2)</sup> For dimensions, see drawing(s) for each construction type on the following page(s).

## Specifications

Pipe size	Orifice size (mm)	Flow coefficient Kv (m <sup>3</sup> /h) (l/min)		Operating pressure differential (bar)							Power coil (W)		Catalog number		Options			
				Min.	Max. (PS)								Brass	Stainless steel	Maintained manual operator	FPM	EPDM	CR
					Air (*)	Water (*)	Oil (*)	~	=	~								
<b>NC - Normally closed</b>																		
Rp 3/8"	16	2.6	43	0	16	16	16	16	-	-	10.5	16.8	SCE210C493	-	MO	V	E	J
Rp 1/2"	16	3.4	57	0	16	16	16	16	-	-	10.5	16.8	SCE210C494	-	MO	V	E	J
					16	16	16	16	16	-	-	16.7	16.8	-	SCE210C487	MO	V	E
Rp 3/4"	19	4.3	72	0	16	16	16	16	-	-	10.5	16.8	SCE210D495	-	MO	V	E	J
		3.9	65	0	16	16	16	16	16	-	-	16.7	16.8	-	SCE210C488	MO	V	E
Rp 1"	25	9.6	160	0	16	16	16	16	10	15.4	23	23	SCE210B454 <sup>(3)</sup>	-	MO	V	E	J
													-	SCE210D489	-	V	E	J
Rp 1 1/4"	28	12.8	213	0	9	6	9	6	9	4	15.4	23	SCE210B155 <sup>(3)</sup>	-	MO	V	E	J
Rp 1 1/2"	32	19.3	322	0	9	5	9	5	9	3	15.4	23	SCE210B156 <sup>(3)</sup>	-	MO	V	E	J

<sup>(3)</sup> Mounting position, DC only: piping horizontal, solenoid upright.

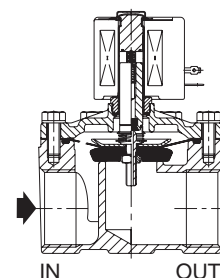
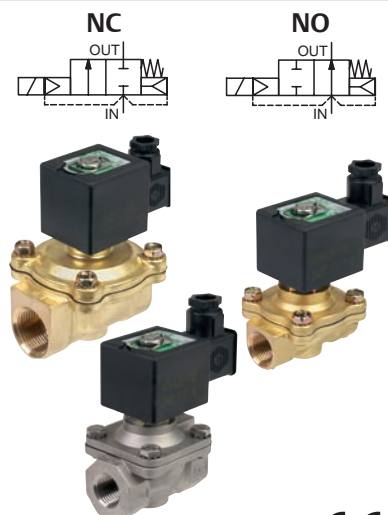

NC function

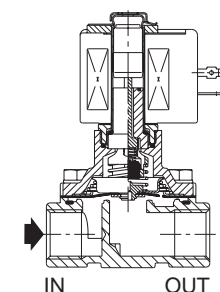

NO function

**Specifications**

Pipe size	Orifice size (mm)	Flow coefficient Kv (m <sup>3</sup> /h) (l/min)		Operating pressure differential (bar)						Power coil (W)		Catalog number		Options				
				Min.	Max. (PS)			Brass	Stainless steel					Maintained manual operator	FPM	EPDM	CR	
					Air (*)	Water (*)	Oil (*)											
<b>NO - Normally open</b>																		
Rp 3/8"	16	2.6	43	0	16	16	16	16	16	10	10.5	23	<b>SCE210C433</b>	-	-	V	E	J
Rp 1/2"	16	3.4	57	0	16	16	16	16	16	10	10.5	23	<b>SCE210C434</b>	-	-	V	E	J
		2.6	43	0	16	16	16	16	16	10	10.5	23	-	<b>SCE210B430</b>	-	V	E	J
Rp 3/4"	19	4.7	79	0	16	16	16	16	16	10	10.5	23	<b>SCE210C435</b>	-	-	V	E	J
	16	2.6	43	0	16	16	16	16	10	10.5	23	-	<b>SCE210B438</b>	-	V	E	J	
Rp 1"	25	11.2	185	0	16	-	16	-	16	-	20	-	<b>SCE210B457</b> <sup>(1)</sup>	-	-	V	E	J
Rp 1 1/4"	28	12.8	213	0	9	-	9	-	9	-	20	-	<b>SCE210B058</b> <sup>(1)</sup>	-	-	V	E	J
Rp 1 1/2"	32	19.3	322	0	9	-	9	-	9	-	20	-	<b>SCE210B059</b> <sup>(1)</sup>	-	-	V	E	J

(\*) Ensure that compatibility of materials in contact with fluids is verified.  
<sup>(1)</sup> Mounting position: piping horizontal, solenoid upright.

**Options**

- Valves can also be supplied with FPM (fluoroelastomer), EPDM (ethylene-propylene) and CR (chloroprene) diaphragms, seals and discs. Use the appropriate optional suffix letter for identification
- Waterproof enclosure with embedded screw terminal coil according to protection class IP67, CEE-10
- Explosionproof enclosures for use in zones 1/21-2/22, categories 2-3 to ATEX Directive 2014/34/EU
- Electrical enclosures according to "NEMA" standards are available
- Compliance with "UL", "CSA" and other local approvals available on request
- Mounting brackets for brass bodied valves, suffix MB (Except pipe size Rp 1, 1 1/4 and 1 1/2)
- For protection against corrosion caused by the environment or the fluid, contact us
- Other pipe connections are available on request
- Connector with visual indication and peak voltage suppression or with cable length of 2 m

**Installation**

- The solenoid valves can be mounted in any position without affecting operation, unless indicated otherwise in the specifications table.
- Stainless steel valves are standard supplied with mounting brackets
- Pipe connection is E = Rp (ISO 7/1)
- Installation/maintenance instructions are included with each valve

**Spare parts kit and accessories**

Catalog number	Spare parts kits no.		Mounting bracket
	~	=	
SCE210C493/C494	<b>C302272</b>	<b>C326540</b>	<b>038713-000</b>
SCE210D495	<b>C302276</b>	<b>C326541</b>	<b>038713-000</b>
SCE210B454	<b>C302283</b>	<b>C326542</b>	-
SCE210B155	<b>C302283</b>	<b>C133801</b>	-
SCE210B156	<b>C302286</b>	<b>C133802</b>	-
SCE210C433/C434	<b>C326551</b>	<b>C326543</b>	<b>038713-000</b>
SCE210C435	<b>C326552</b>	<b>C326544</b>	<b>038713-000</b>
SCE210B457	<b>C302337</b>	-	-
SCE210B058	<b>C302339</b>	-	-
SCE210B059	<b>C302340</b>	-	-
SCE210C487/C488	<b>C302328</b>	<b>C326548</b>	<b>standard</b>
SCE210B430/B438	<b>C326553</b>	<b>C326550</b>	<b>standard</b>
SCE210D489	<b>C302329</b>	<b>C326549</b>	-

- Not available

**Ordering Examples Valves:**

SC	E	210	C 493	230V / 50 Hz
SC	E	210	C 494	<b>MO</b> 115V / 50 Hz
SC	E	210	C 487	<b>V</b> 24V / DC
SC	E	210	D 489	230V / 50 Hz

prefix — pipe thread — basic number — voltage — suffix

**Ordering Examples Kits:**

C302272 <sup>(2)</sup>	
C302276	<b>V</b>
C302280	<b>E</b>

basic number — suffix

<sup>(2)</sup> Standard prefixes/suffixes are also applicable to kits.

## Dimensions (mm), Weight (kg)



**TYPE 01-02**  
Prefix "SC" Solenoid  
Epoxy moulded  
IEC 335 / ISO 4400  
IP65

Type 01: SCE210C493/C494/D495 (AC)  
SCE210C487/C488 (AC)

Type 02: SCE210C493/C494/D495/C487/C488 (DC)  
SCE210D489/B454/B155 (AC/DC)

Type 02: SCE210B156 (AC/DC)

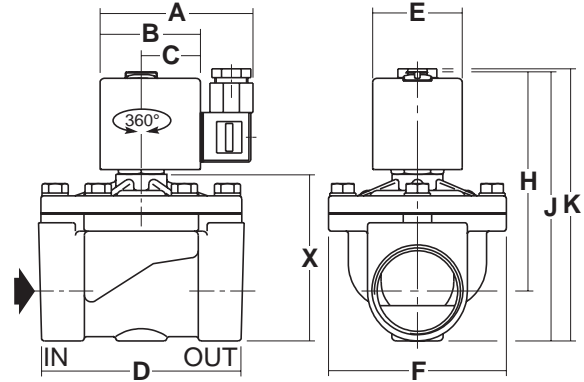
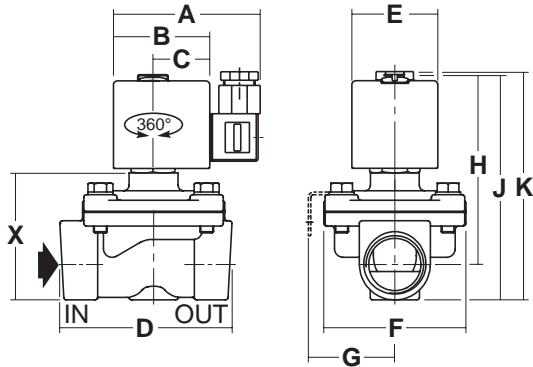

Type 01: SCE210C433/C434/C435 (AC)  
SCE210B430/B438 (AC)

Type 02: SCE210B457/B058/B059 (AC/DC)

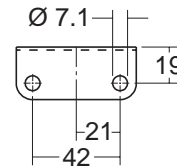
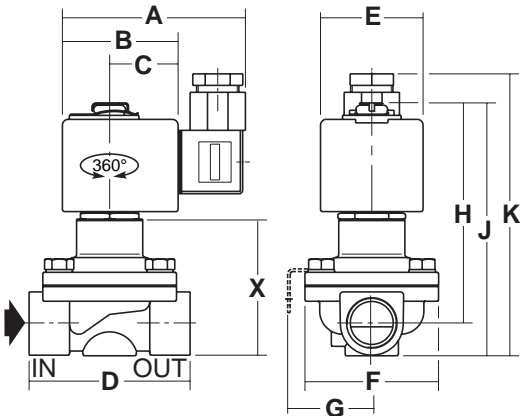

Mounting brackets for valves: (0.3 kg)  
SCE210C493/C494/D495  
SCE210C487/C488/D489  
SCE210C433/C434/C435

Type	Prefix option	Catalog number	A	B	C	D	E	F	G	H	J	K	X	Weight <sup>(1)</sup>
01	SC	SCE210C493/C494	86	51	30	70	45	58	41	83	98	112	46	0.9
		SCE210D495	86	51	30	71	45	58	41	87	105	119	54	1.0
		SCE210C487/C488	86	51	30	71	45	58	41	87	105	119	55	1.0
		SCE210C433/C434	86	51	30	70	45	58	41	95	109	120	60	0.9
		SCE210C435	86	51	30	71	45	58	41	99	117	127	68	1.0
02	SC	SCE210B430/B438	86	51	30	71	45	58	41	98	116	127	67	1.0
		SCE210C493/C494	91	56	33	70	50	58	41	93	107	104	46	1.0
		SCE210D495	91	56	33	71	50	58	41	97	115	111	54	1.1
		SCE210C487/C488	91	56	33	71	50	58	41	97	116	112	55	1.1
		SCE210D489	91	56	33	95	50	98	41	112	134	134	75	2.2
		SCE210C433/C434	91	56	33	70	50	58	41	101	116	112	60	1.1
		SCE210C435	91	56	33	71	50	58	41	105	123	119	68	1.2
		SCE210B430/B438	91	56	33	71	50	58	41	105	123	119	67	1.1
		SCE210B454	91	56	33	95	50	83	-	114	134	131	75	2.0
		SCE210B457	91	56	33	95	50	83	-	155	176	160	98	2.1
		SCE210B155	86	56	33	95	50	83	-	112	143	148	86	2.0
		SCE210B156	86	56	33	111	50	99	-	125	153	158	96	2.8
		SCE210B058	86	56	33	95	50	83	-	161	187	187	130	2.0
		SCE210B059	86	56	33	111	50	99	-	167	194	194	137	2.5

<sup>(1)</sup> Incl. coil(s) and connector(s)