

End bearings

Axially locating flanged housing with SKF angular contact ball bearings (back to back arrangement).

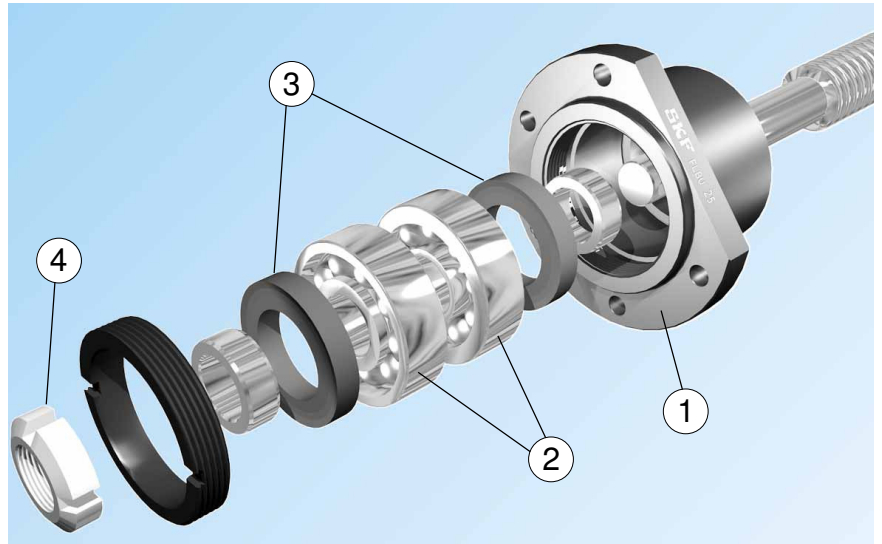

The “FLBU” flanged bearing unit consists of :

- precision housing, made of burnished steel (1)
- two SKF preloaded angular contact ball bearings, 72 or 73 series (2)
- two garter seals (3)
- locknut, self-locking Nylstop type (4) or, on demand, high precision KMT

The “FLBU” flanged thrust bearing unit provides the following benefits :

- lubrication for life
- very easy mounting (matched bearings, hand mounting on the shaft end) as well as easy disassembly with the optional high precision KMT nut.

In standard version, the “FLBU” thrust bearing unit is assembled according to drawing page 27. If you require a different assembly, please indicate it when ordering.

		Angular contact ball bearing (40°)			Lock nut						
		Basic load rating (axial)		SKF Bearing designation	Self locking nut		High precision nut 4/				
Size d ₀	Flanged bearing unit designation	C _a (kN)	C _{0a} (kN)		Designation	Hook spanner	Designation	Hook spanner	Tightening torque (Nm)	Grub screws	
										Size	Max tightening torque (Nm)
16	FLBU 16 1/	12.2	12.8	7200 BECB 2/	CN 70-10	HN 1	KMT 0	HN 2/3	4	M 5	4.5
20	FLBU 20	13.3	14.7	7201 BEGA 3/	CN 70-12	HN 1	KMT 1	HN 3	8	M 5	4.5
25	FLBU 25	27.9	31.9	7303 BEGA 3/	CN 70-17	HN 3	KMT 3	HN 4	15	M 6	4.5
32	FLBU 32	24.6	31.9	7204 BEGA 3/	CN 70-20	HN 4	KMT 4	HN 5	18	M 6	8
40	FLBU 40	41.9	59.6	7206 BEGA 3/	CN 70-30	HN 6	KMT 6	HN 6	32	M 6	8
50	FLBU 50	54.5	79.8	7207 BEGA 3/	CN 70-35	HN 7	KMT 7	HN 7	40	M 6	8
63	FLBU 63 1/	128	196.1	7310 BEGA 3/	CN 70-50	HN 10	KMT 10	HN 10/11	60	M 6	8
80	FLBU 80 1/	148	230.7	7311 BEGA 3/	CN 70-55	HN 11	KMT 11	HN 12/13	70	M 8	18

1/ Dimensions on request
2/ No backlash elimination

3/ Light preload
4/ Optional

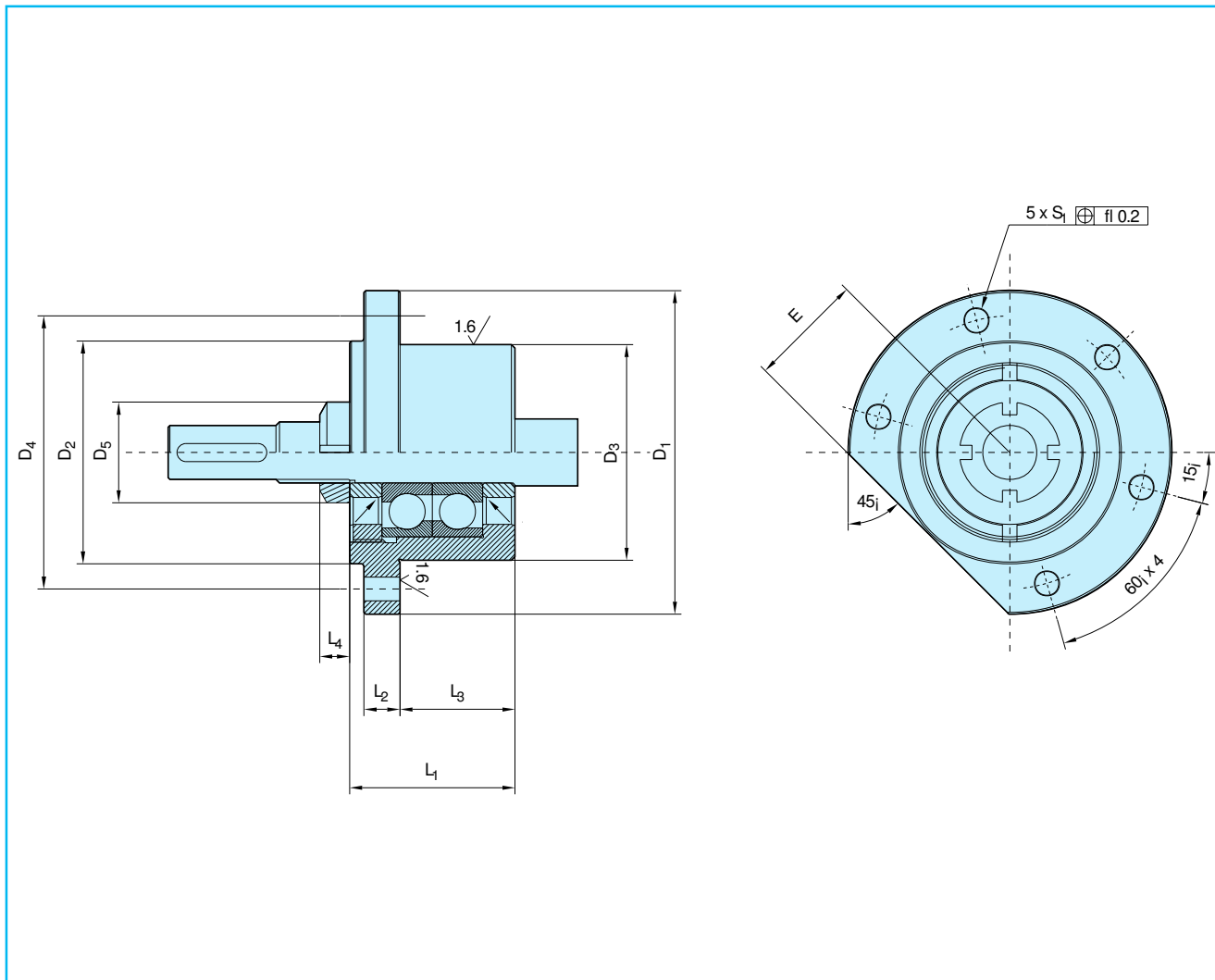

Dimensions (mm)

Size d ₀	L ₁	L ₂	L ₃	L ₄		D ₁	D ₂	D ₃	D ₄	D ₅		S ₁ H13	Fixing screws	E
				Self locking nut	High precision nut 1/					Self locking nut	High precision nut 1/			
16	37	10	22	7	14	76	50	47	63	18	28	6.6	M6 x 30	26
20	42	10	25	7.5	14	76	50	47	63	21	30	6.6	M6 x 30	27
25	46	10	32	8.3	18	90	62	60	76	28	37	6.6	M6 x 30	32
32	49	13	32	8.3	18	90	59	60	74	32	40	9	M8 x 40	32
40	53	16	32	11	20	120	80	80	100	44	49	11	M10 x 45	44
50	59	20	32	11	22	130	89	90	110	50	54	13	M12 x 60	49
63	85	25	43.5	11.7	25	165	124	124	146	68	75	13	M12 x 60	64
80	90	20	60	13.8	25	190	140	140	166	74	85	17	M16 x 65	70

1/ Optional

End bearings

Fixed plummer housing with SKF angular contact ball bearings (back to back arrangement)

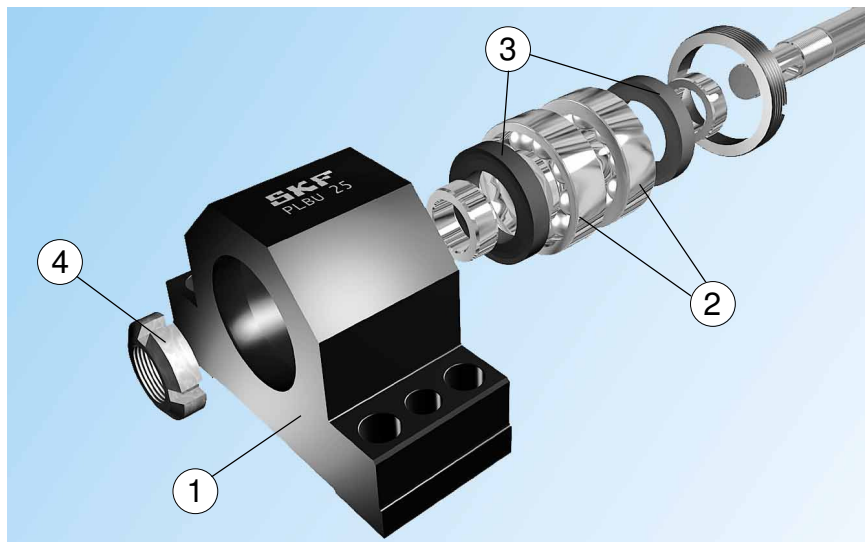

The “PLBU” plummer bearing unit consists of :

- precision housing, made of burnished steel, with precision reference edges on both sides, steel (1)
- two SKF preloaded angular contact ball bearings, 72 or 73 series (2)
- two garter seals (3)
- locknut, self-locking Nylstop type (4) or, on demand, high precision KMT

The “PLBU” plummer bearing unit provides the following benefits :

- lubrication for life
- very easy mounting (matched bearing, hand mounting on the shaft ends) as well as easy disassembly with the optional high precision KMT nut
- good rigidity guaranteed by foot mounting with dowel pins

		Angular contact ball bearing (40°)			Lock nut						
		Basic load rating (axial)		SKF Bearing designation	Self locking nut		High precision nut 4/				
Size d ₀	Plummer bearing unit designation (fixed)	C _a (kN)	C _{oa} (kN)		Designation	Hook spanner	Designation	Hook spanner	Tightening torque (Nm)	Grub screws	
										Size	Max tightening torque (Nm)
16	PLBU 16 1/	12.2	12.8	7200 BECB 2/	CN 70-10	HN 1	KMT 0	HN 2/3	4	M 5	4.5
20	PLBU 20	13.3	14.7	7201 BEGA 3/	CN 70-12	HN 1	KMT 1	HN 3	8	M 5	4.5
25	PLBU 25	27.9	31.9	7303 BEGA 3/	CN 70-17	HN 3	KMT 3	HN 4	15	M 6	4.5
32	PLBU 32	24.6	31.9	7204 BEGA 3/	CN 70-20	HN 4	KMT 4	HN 5	18	M 6	8
40	PLBU 40	41.9	59.6	7206 BEGA 3/	CN 70-30	HN 6	KMT 6	HN 6	32	M 6	8
50	PLBU 50	54.5	79.8	7207 BEGA 3/	CN 70-35	HN 7	KMT 7	HN 7	40	M 6	8
63	PLBU 63 1/	128	196.1	7310 BEGA 3/	CN 70-50	HN 10	KMT 10	HN 10/11	60	M 6	8
80	PLBU 80 1/	148	230.7	7311 BEGA 3/	CN 70-55	HN 11	KMT 11	HN 12/13	70	M 8	18

1/ Dimensions on request
2/ No backlash elimination

3/ Light preload
4/ Optional

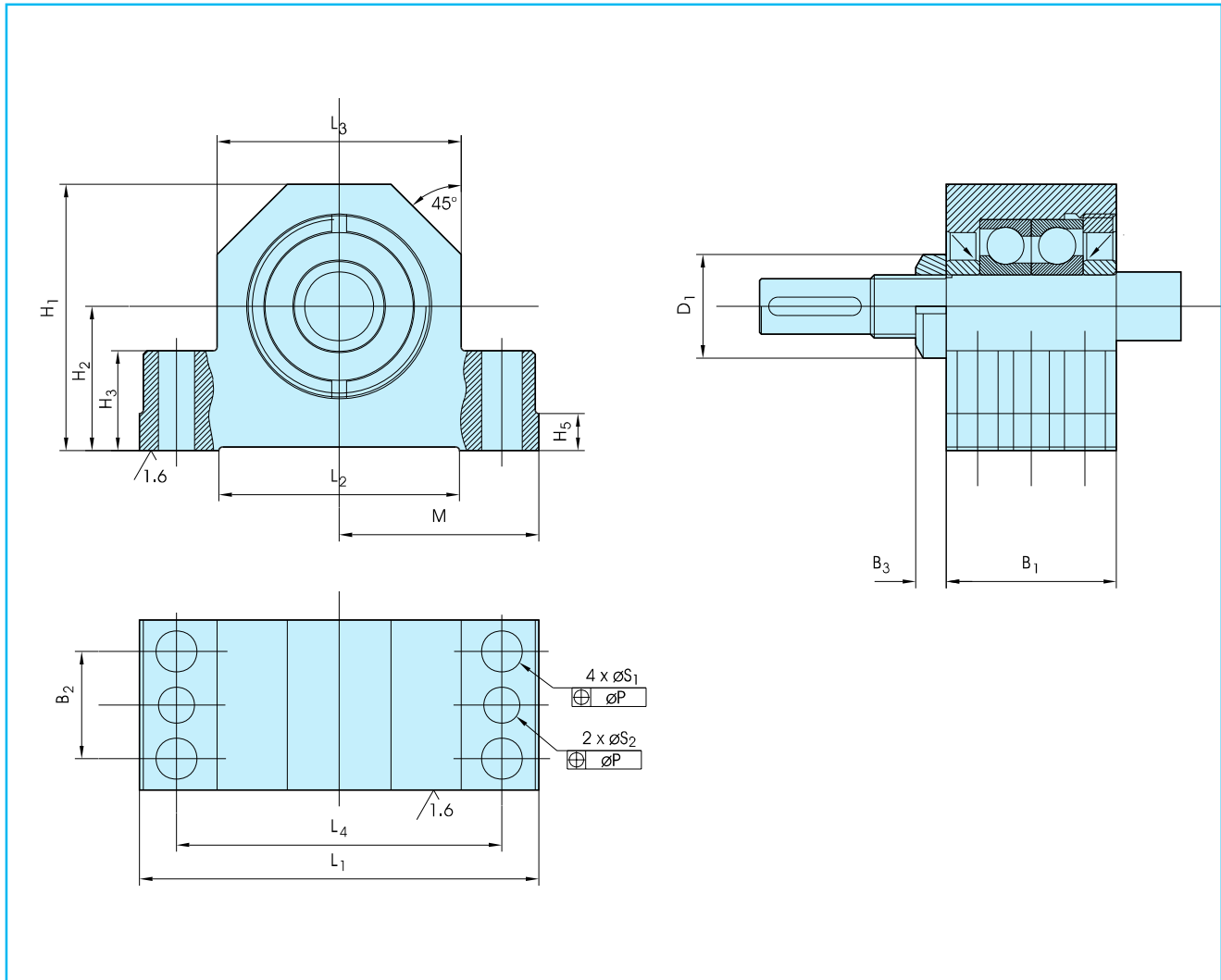

Dimensions (mm)

Size d ₀	L ₁	L ₂	L ₃	L ₄	M	B ₁	B ₂	B ₃		H ₁	H ₂	H ₃	H ₄	H ₅	S ₁	P	Fixing screws	S ₂	D ₁		Tapered pin (hardened) or straight pin (DIN6325)	
								Self locking nut	High precision nut 1/										H12	Self locking nut		High precision nut 1/
16	86	52	52	68	43	37	23	7	14	58	32	22	15	8	9	0.15	M8 x 35	7.7	18	28	8 x 40	
20	94	52	60	77	47	42	25	7.5	14	64	34	22	17	8	9	0.15	M8 x 35	7.7	21	30	8 x 40	
25	108	65	66	88	54	46	29	8.3	18	72	39	27	19	10	11	0.2	M10 x 40	9.7	28	37	10 x 50	
32	112	65	70	92	56	49	29	8.3	18	77	45	27	20	10	11	0.2	M10 x 40	9.7	32	40	10 x 50	
40	126	82	80	105	63	53	32	11	20	98	58	32	23	12	13	0.2	M12 x 50	9.7	44	49	10 x 50	
50	144	80	92	118	72	59	35	11	22	112	65	38	25	12	13	0.2	M12 x 55	9.7	50	54	10 x 55	
63	190	110	130	160	95	85	40	11.7	25	130	65	49	35	15	13	0.2	M12 x 65	9.7	68	75	10 x 65	
80	205	120	145	175	102.5	90	60	13.8	25	162	90	50	40	25	17	0.2	M16 x 80	11.7	74	85	12 x 80	

1/ Optional

End bearings

Axially free plummer housing with SKF deep-groove ball bearing

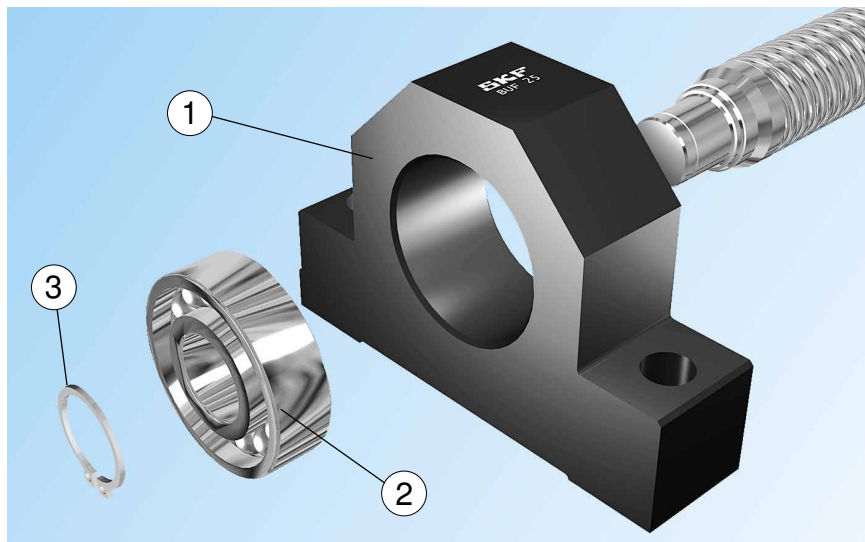

The “BUF” plummer bearing unit consists of :

- bearing housing made of burnished steel, with one reference side ①
- grease-tight deep-groove SKF ball bearing, greased for life, type 62... 2RS1 ②
- retaining ring ③

In standard version, the “BUF” thrust bearing unit is assembled according to drawing page 31. If you require a different assembly, please indicate it when ordering.

		Deep-groove ball bearing						Retaining ring (DIN 471)
		Basic load rating (radial)		SKF Bearing designation	Dimensions (mm)			
Size d_0	Plummer bearing unit designation (free)	C_a (kN)	C_{oa} (kN)		d	D	B	
16	BUF 16 1/	5.07	2.36	6200.2RS1	10	30	9	10x1
20	BUF 20	5.07	2.36	6200.2RS1	10	30	9	10x1
25	BUF 25	9.56	4.75	6203.2RS1	17	40	12	17x1
32	BUF 32	9.56	4.75	6203.2RS1	17	40	12	17x1
40	BUF 40	19.5	11.2	6206.2RS1	30	62	16	30x1.5
50	BUF 50	19.5	11.2	6206.2RS1	30	62	16	30x1.5
63	BUF 63 1/	33.2	21.6	6209.2RS1	45	85	19	45x1.75
80	BUF 80 1/	33.2	21.6	6209.2RS1	45	85	19	45x1.75

1/ Dimensions on request

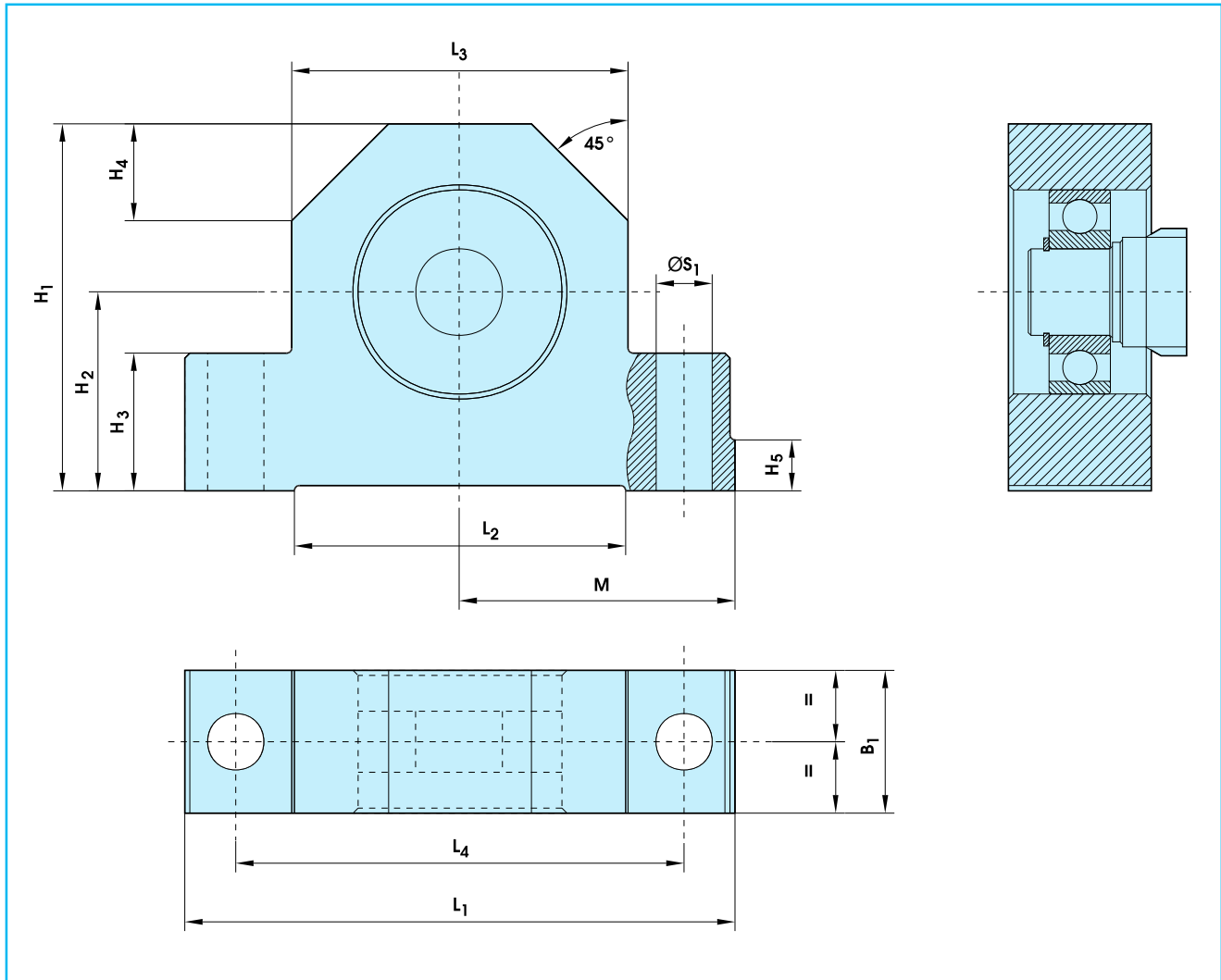

Dimensions (mm)

Size d_0	L_1	L_2	L_3	L_4	M	B_1	H_1	H ₂	H_3	H_4	H_5	S_1	Fixing screws
					js8			js8				H12	
16	86	52	52	68	43	24	58	32	22	15	8	9	M8 x 35
20	94	52	60	77	47	26	64	34	22	17	8	9	M8 x 35
25	108	65	66	88	54	28	72	39	27	19	10	11	M10 x 40
32	112	65	70	92	56	34	77	45	27	20	10	11	M10 x 40
40	126	82	80	105	63	38	98	58	32	23	12	13	M12 x 50
50	144	80	92	118	72	39	112	65	38	25	12	13	M12 x 55
63	190	110	130	160	95	38	130	65	49	35	15	13	M12 x 65
80	205	120	145	175	102.5	40	162	90	50	40	25	17	M16 x 80

