

60.0050

PRZEWÓD POLIETYLENOWY
PE HOSES

Wymiary przewodu Dimension $D_z \times g$	Max. ciśnienie pracy przy temp. 20°C Working pressure at 20°C [MPa]	Nr zamówieniowy Code number	
		Przewód biały white hose	Przewód niebieski blue hose
4×1	0.6	60.0050.0401B	60.0050.0401N
6×1	0.6	60.0050.0601B	60.0050.0601N
8×1	0.6	60.0050.0801B	60.0050.0801N
10×1	0.6	60.0050.1001B	60.0050.1001N
12×2	0.6	60.0050.1202B	60.0050.1202N
16×2	0.6	60.0050.1602B	60.0050.1602N
20×2	0.6	60.0050.2002B	60.0050.2002N

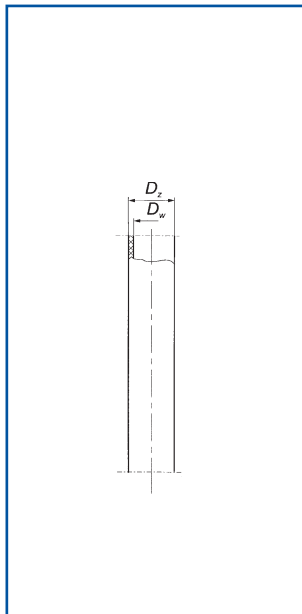
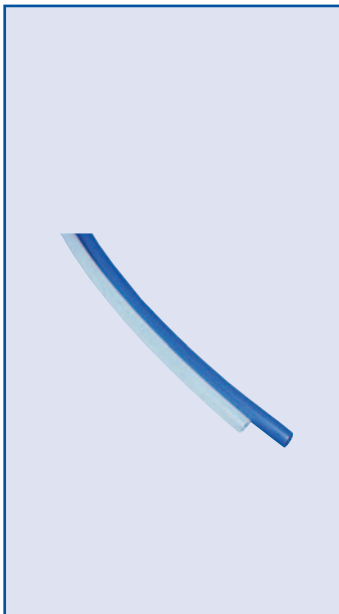

60.0051

PRZEWÓD POLIETYLENOWY KALIBROWANY
(DO PRZYŁĄCZEK WTYKOWYCH)
PE HOSES FOR QUICK FITTINGS

Wymiary przewodu Dimension $D_z \times D_w$	Max. ciśnienie pracy przy temp. 20°C Working pressure at 20°C [MPa]	Nr zamówieniowy Code number	
		Przewód biały white hose	Przewód niebieski blue hose
4/2	1.2	60.0051.01B	60.0051.01N
6/4	1.2	60.0051.02B	60.0051.02N
8/6	0.8	60.0051.03B	60.0051.03N
10/8	0.7	60.0051.04B	60.0051.04N

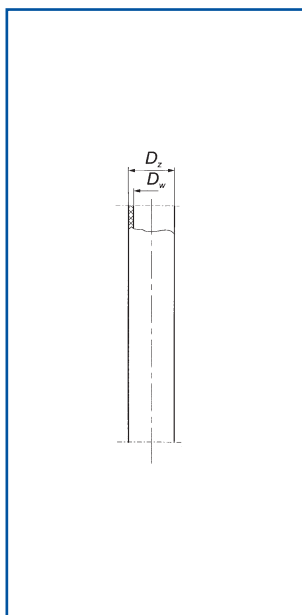
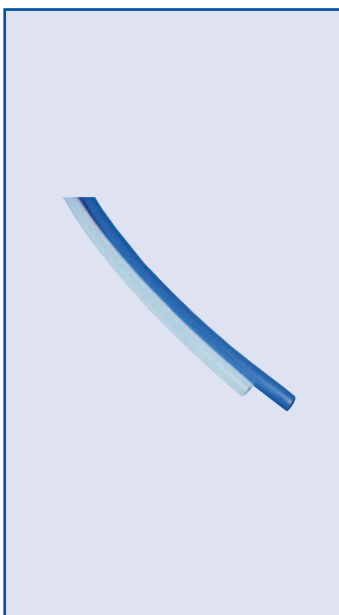

60.0052

PRZEWÓD POLIAMIDOWY PA
PA HOSES

Wymiary przewodu Dimension $D_z \times D_w$	Max. ciśnienie pracy przy temp. 20°C Working pressure at 20°C [MPa]	Min. promień gięcia Min. bending radius [mm]	Numer zamówieniowy Code number	
			Przewód biały white hose	Przewód niebieski blue hose
4/2	4	16	60.0052.0402B	60.0052.0402N
6/4	2	35	60.0052.0604B	60.0052.0604N
8/6	1.5	65	60.0052.0806B	60.0052.0806N
10/8	1.2	100	60.0052.1008B	60.0052.1008N

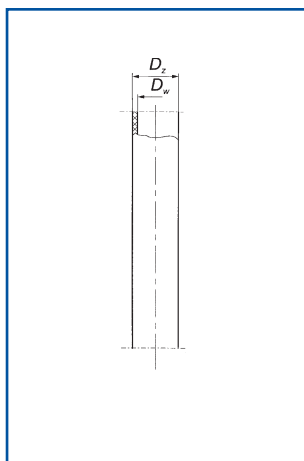

80.0259

PRZEWÓD POLIAMIDOWY PA

Przewód poliamidowy	kolorowy 12/9
BIAŁY	80.0259.12 BI
CZARNY	80.0259.12 CZ
CZERWONY	80.0259.12 CZR
NIEBIESKI	80.0259.12 NI

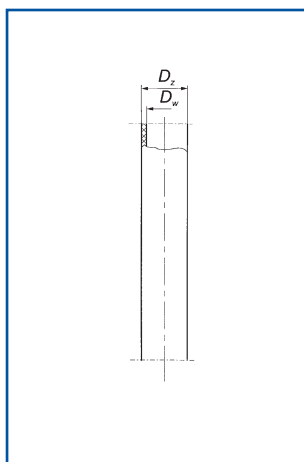
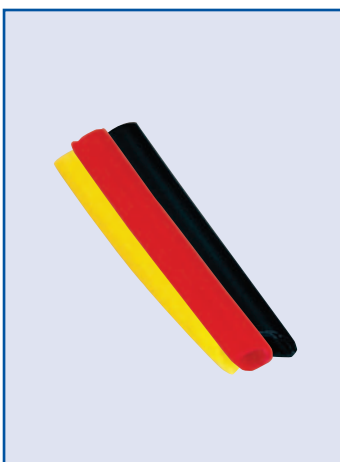

80.0259.149/150

PRZEWÓD POLIURETANOWY PU

PU HOSES

Wymiary przewodu Dimension	Max. ciśnienie pracy przy temp. 20°C Working pressure at 20°C	Numer zamówieniowy Code number
$D_z \times D_w$	[MPa]	
4/2	12	80.0259.149.042
6/4	10	80.0259.150.064
8/5	10	80.0259.150.185
8/6	7	80.0259.150.186
10/8	6	80.0259.150.108
12/8	8	80.0259.150.128

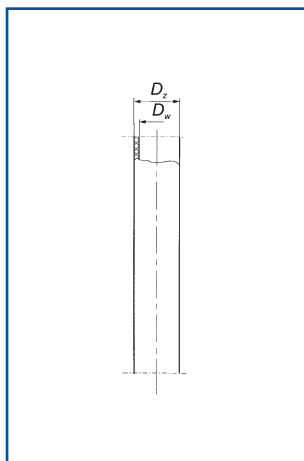
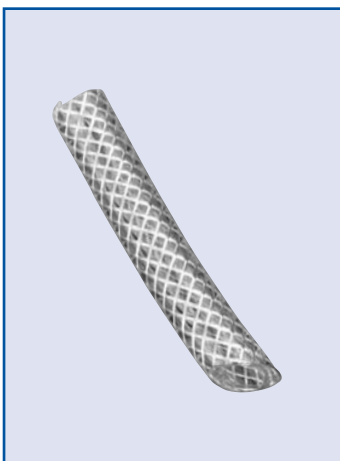

80.0053

WAŻ ZBROJONY Z PCV / PCV HOSES

Wymiary przewodu Dimension	Max. ciśnienie pracy przy temp. 20°C Working pressure at 20°C	Numer zamówieniowy Code number
$D_z \times D_w$	[MPa]	
10/4	2.3	80.0053.1004
12/6	2.3	80.0053.1206
14/8	2.2	80.0053.1408
15/9	1.9	80.0053.1509
16/10	1.7	80.0053.1610
18.5/12.5	1.4	80.0053.185125
20/13	1.4	80.0053.2013
23/16	1.3	80.0053.2316
26/19	1.1	80.0053.2619
34/25	0.9	80.0053.3425
42/32	0.7	80.0053.4232
58/50	0.7	80.0053.5850

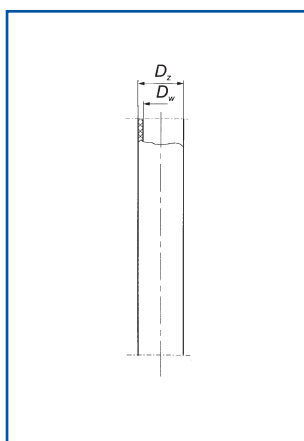
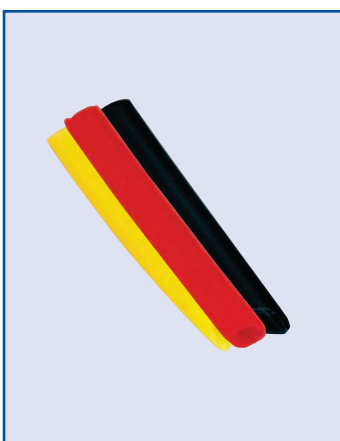

80.0259

PRZEWÓD POLIETYLENOWY KOLOROWY

PE COLOR HOSES FOR QUICK FITTINGS

Wymiary przewodu Dimension	Max. ciśnienie pracy przy temp. 20°C Working pressure at 20°C	Numer zamówieniowy Code number				
		Przewód biały white hose	Przewód niebieski blue hose	Przewód czerwony red hose	Przewód żółty yellow hose	Przewód czarny black hose
$D_z \times D_w$	[MPa]					
4/2	0.6	80.0259.05N	80.0259.05B	80.0259.05R	80.0259.05G	80.0259.05S
6/4	0.6	80.0259.01N	80.0259.01B	80.0259.01R	80.0259.01G	80.0259.01S
8/6	0.6	80.0259.02N	80.0259.02B	80.0259.02R	80.0259.02G	80.0259.02S
10/8	0.6	80.0259.03N	80.0259.03B	80.0259.03R	80.0259.03G	80.0259.03S

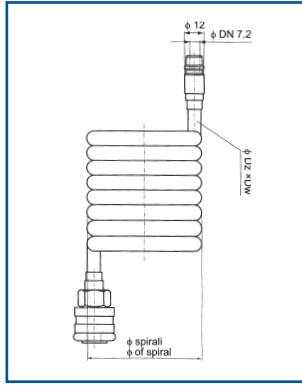

80.0001

WAŻ ELASTYCZNY SPIRALNY Z POLIAMIDU PA FLEXIBLE PA HOSES

Wymiar węża Dimension $D_z \times D_w$	Max. ciśnienie pracy przy temp. 20°C Working pressure at 20°C [MPa]	Długość węża Hose length [m]	Średnica spirali Spiral diameter [mm]	Numer zamówieniowy Code number
10/8	1.0	10	110	80.0001.1008.10
10/8	1.0	15	110	80.0001.1008.15
12/10	1.0	10	110	80.0001.1210.10
12/10	1.0	15	110	80.0001.1210.15

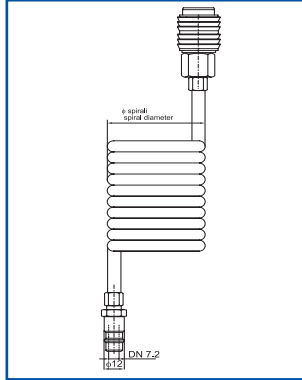

80.0003

WAŻ ELASTYCZNY SPIRALNY Z POLIURETANU PU FLEXIBLE PU HOSES

Wymiar węża Dimension $D_z \times D_w$	Max. ciśnienie pracy przy temp. 20°C Working pressure at 20°C [MPa]	Długość węża Hose length [m]	Średnica spirali Spiral diameter [mm]	Numer zamówieniowy Code number
8/5	1.0	4	55	80.0003.0805.04
8/5	1.0	8	55	80.0003.0805.08
8/5	1.0	15	55	80.0003.0805.12
12/8	1.0	4	90	80.0003.1208.04
12/8	1.0	9	90	80.0003.1208.08
12/8	1.0	15	90	80.0003.1208.12



80.0022

OPASKA ZACISKOWA CLAMPING GRIP

PRZEWÓD TUBE	Nr zamówieniowy Code number
8 ÷ 12	80.0022.0812
8 ÷ 16	80.0022.0816
12 ÷ 22	80.0022.1222
16 ÷ 27	80.0022.1627
20 ÷ 32	80.0022.2030
25 ÷ 40	80.0022.2540
32 ÷ 50	80.0022.3250
50 ÷ 70	80.0022.5070
70 ÷ 90	80.0022.7090
60 ÷ 80	80.0022.6080
80 ÷ 100	80.0022.80100

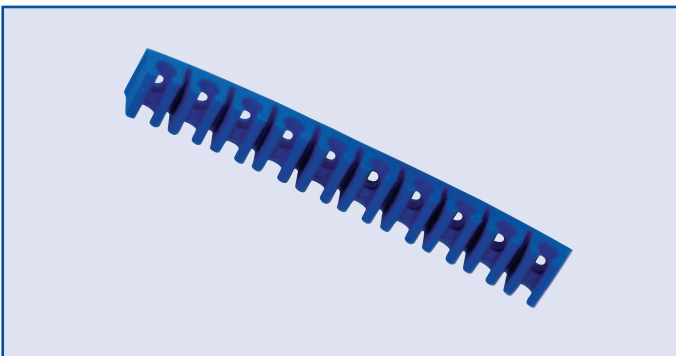

80.0100

PROWADNICA DO PRZEWODÓW Z TWORZYWA FOR PLASTIC HOSES

Średnica zewnętrzna D_z przewodu Outside hose diameter	Ilość uchwytów Numbers of grippers	Nr zamówieniowy Code number
6	10	80.0100.06
8	10	80.0100.08
10	6	80.0100.10



80.1750.0001

UCINAK DO PRZEWODÓW Z TWORZYWA SZTUCZNEGO PLASTIC PIPE CUTTER

Numer zamówieniowy Code number	80.1750.0001