

# Compact Proportional Solenoid Valve

Repeatability:  
**3% or less**

Hysteresis:  
**10% or less**

Fluid	Flow rate control range <small>Note)</small>	Series
Air, Inert gas	0 to 6 ℓ/min	<b>PVQ10</b>
	0 to 100 ℓ/min	<b>PVQ30</b>

Note) Varies depending on the model.

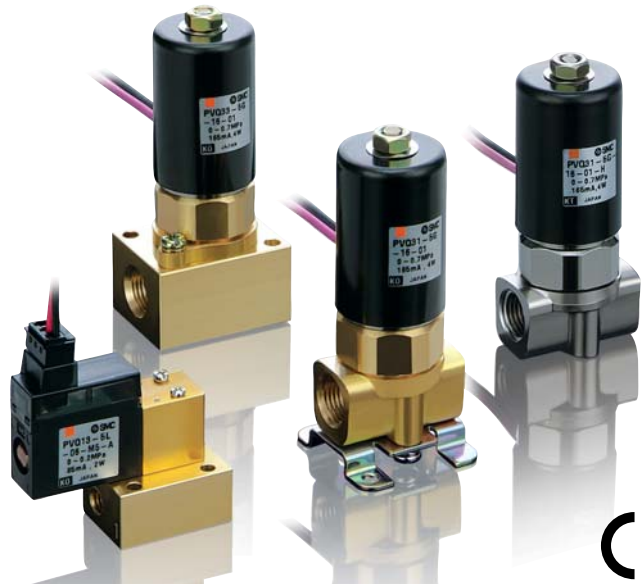

Control the flow rate smoothly according to the current

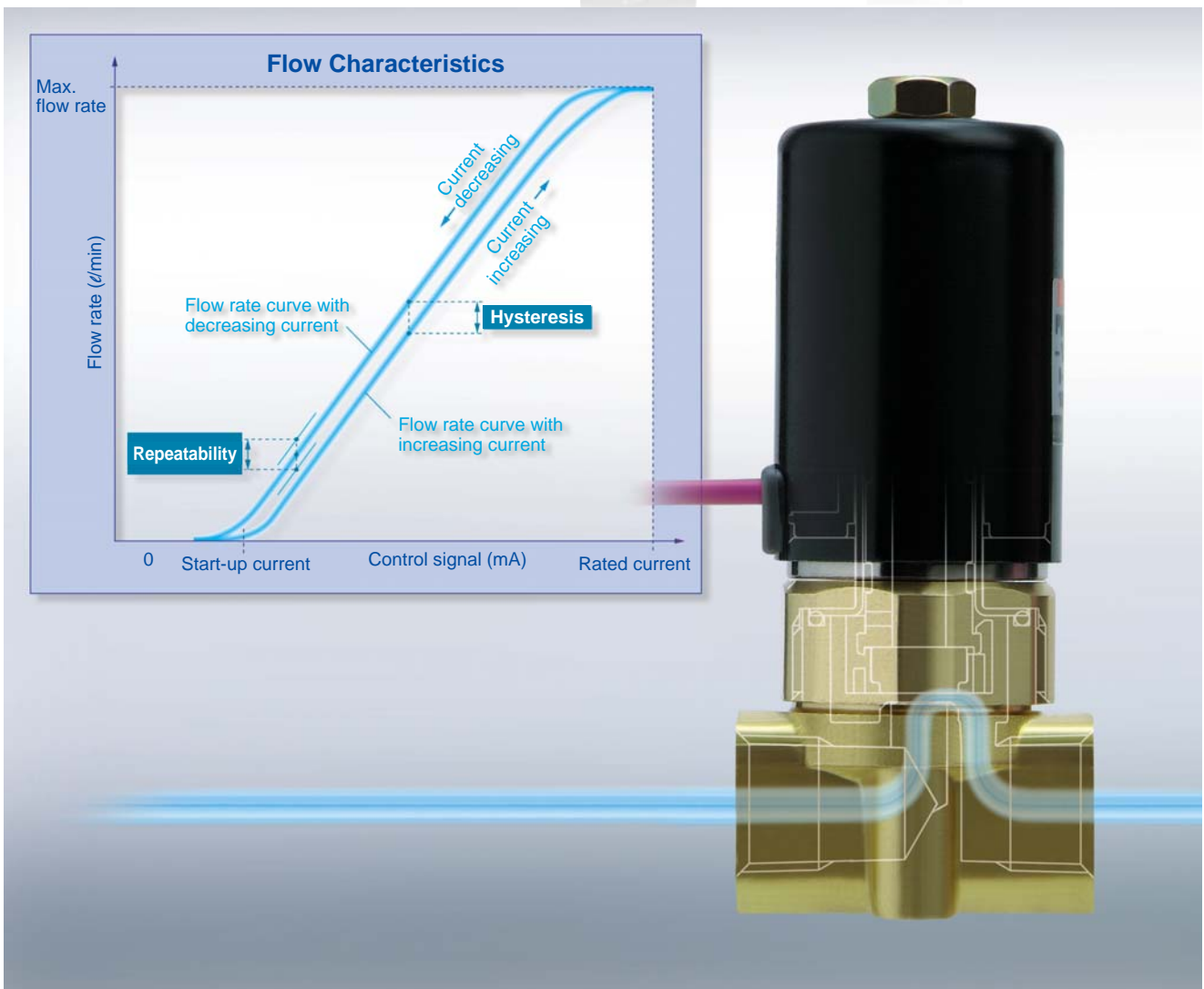

Series **PVQ**

**SMC**  
CAT.EUS70-33A-UK

- **Service life: Lasts 25 million cycles.** (PVQ30)  
(SMC in-house life test conditions)

Specially coated sliding surface realised 25 million cycles within a set operation range

- **Body material: Brass (C36)** (PVQ10),  
**Brass (C37) or Stainless steel** (PVQ30)

**Seal material: FKM** (PVQ10, PVQ30)

- **Valve returns to closed position when power supply is turned off.**

- **Leakage amount: 5 cm<sup>3</sup>/min or less at OFF**

- **Can be used for vacuum applications.** (Minimum operating pressure 0.1 Pa-abs)

- **Operation noise during opening/closing of the valve reduced**

PVQ10	ON	25.6 to 29.1 dB	PVQ30	ON	38.9 to 42.4 dB
	OFF	28.6 to 31.6 dB		OFF	48.4 to 49.7 dB

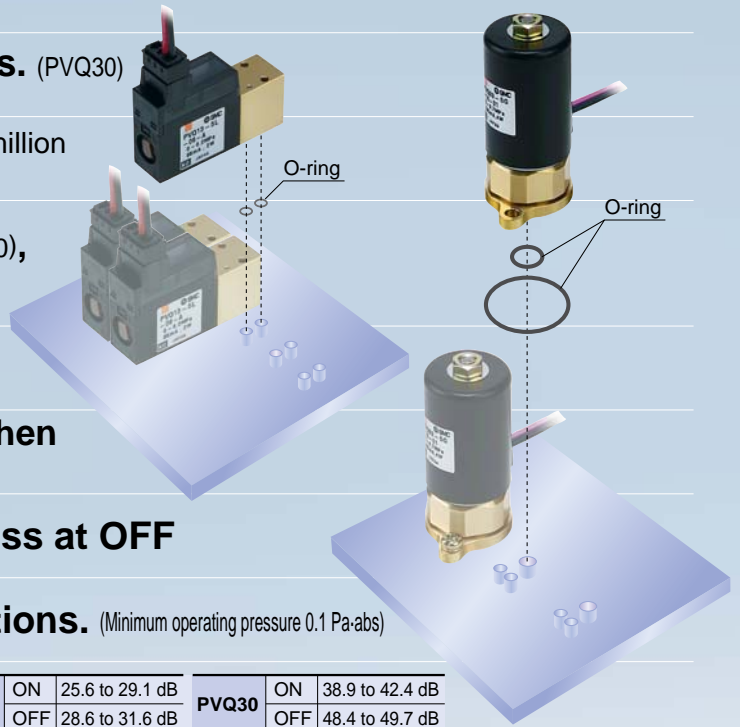

### Working Principle

The armature is attracted to the core by an electromagnetic force as the coil is energised. When the applied current varies, the attraction force also varies proportionally to it. The flow rate is controlled by the movement (stroke) of the armature, depending on the balance between the attraction force and the spring load.

Note) Sliding resistance at this point is the hysteresis of the flow.

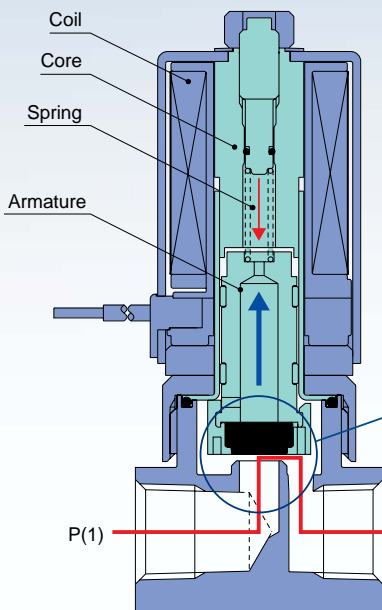

PVQ30

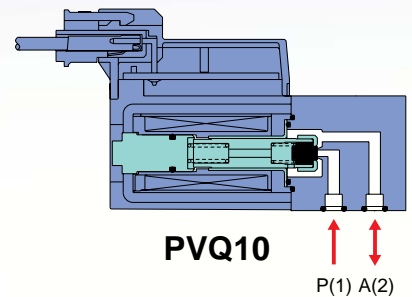
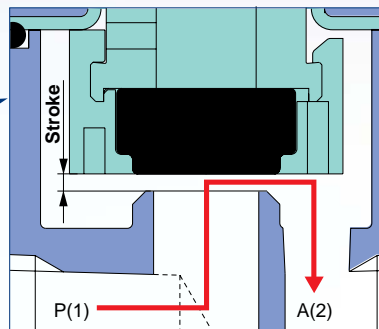

### Proportional Solenoid Valve

Flow rate can be controlled smoothly with one proportional solenoid valve by current control.

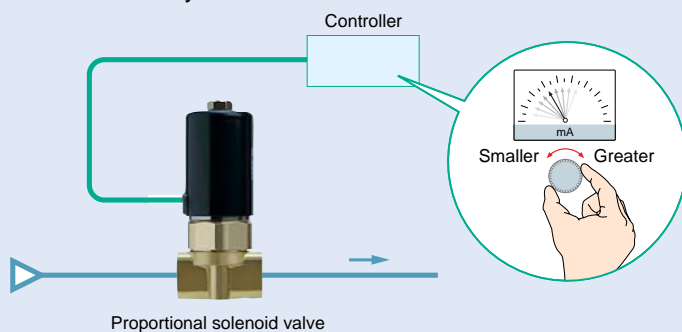

### Conventional (2 port valve)

One 2-port valve is required for each flow rate.

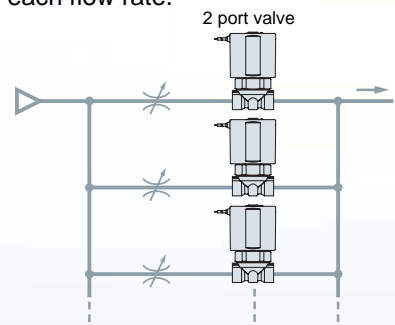

## Applications

### Air-blow

- Blow-off of debris or water.  
Work transportation

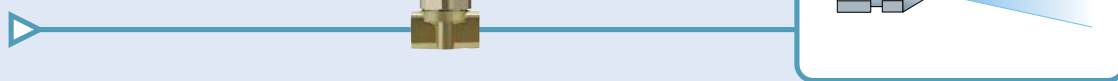

### Spin control of handpiece

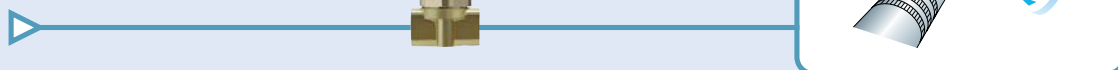



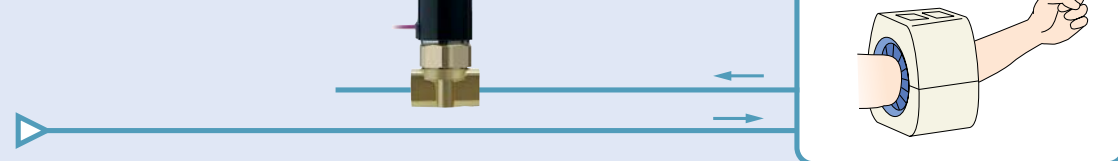

### Blood pressure gauge

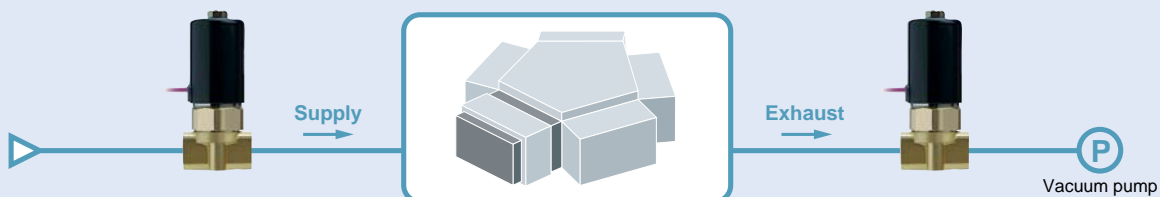

### Vacuum chamber supply flow control

Smooth air supply/exhaust is possible by reducing the initial air supply.  
Prevents dust being stirred up inside the chamber.

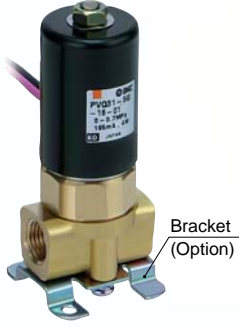

Model	PVQ13				PVQ31		PVQ33	
Piping type	Base mounted				Body ported		Base mounted	
								
Valve construction	Direct operated poppet				Direct operated poppet			
Valve type	N.C.				N.C.			
Orifice size (mm)	0.3	0.4	0.6	0.8	1.6	2.3	4	
Max. operating pressure (MPa)	0.7	0.45	0.2	0.1	0.7	0.35	0.12	
Flow rate (ℓ/min)	0 to 5	0 to 6		0 to 5	0 to 100		0 to 75	
Applied current (Power supply)	0 to 85 mA (24 VDC) 0 to 170 mA (12 VDC)				0 to 165 mA (24 VDC) 0 to 330 mA (12 VDC)			
Port size	M5				1/8			

# Series PVQ Model Selection

## <To use orifice $\phi 1.6$ (See PVQ30: Chart 1)>

Condition 1.  $P_1 = 0.7 \text{ MPa}$ ,  $P_2 = 0 \text{ MPa}$  (Atmospheric pressure)

Refer to curve A when  $\Delta P$  is 0.7 MPa.

- Ex) At increasing currents, when a 140 mA current is applied, a flow rate of 85  $\ell/\text{min}$  is achieved. (See ①.)  
 If current decreases at this point, the flow rate may not change by 135 mA due to hysteresis. (See ②.)  
 The flow rate at an increasing and decreasing current is not the same due to hysteresis. (① 85  $\ell/\text{min}$ ., ③ 93  $\ell/\text{min}$ .)

Condition 2.  $P_1 = 0.7 \text{ MPa}$ ,  $P_2 = 0.2 \text{ MPa}$

Refer to curve B when  $\Delta P$  is 0.5 MPa.

- Ex) At increasing currents, when a 150 mA current is applied, a flow rate of 65  $\ell/\text{min}$  is achieved. (See ④.)  
 If  $P_2$  increases by 0.15 MPa,  $\Delta P$  decreases by 0.15 MPa and becomes 0.35 MPa (See curve C), and when the same current is applied the flow rate is 40  $\ell/\text{min}$ . (See ⑤.)

- The flow rate decreases due to a change (increase) in the outlet pressure, even if the inlet pressure and the current value are the same.

Condition 3. Under vacuum pressure

- For vacuum specifications, the operating pressure range is from 0.1 Pa-abs to max. operating pressure differential.
- A(2) port is applicable with vacuum pressure.

<Chart 1> PVQ30 ( $\phi 1.6$ )

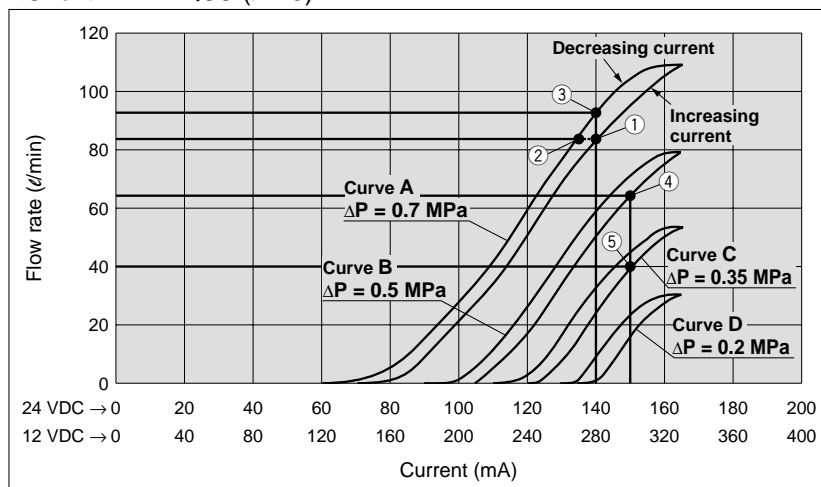

## ● Q. Required flow rate = 0 to 75 $\text{d}/\text{min}$ .

$P_1$  = No conditions,  $P_2$  = 0 MPa (Atmospheric pressure)

In this case, all of PVQ30 series orifice sizes satisfy the required flow rate. (Flow rate when rated current is applied)  
The table below shows the pressure differentials needed to satisfy the required flow rate. In the flow rate characteristic charts, a pressure differential over the flow rate indicated by the dashed line (75  $\text{d}/\text{min}$ .) up to the max. operating pressure differential will satisfy the required flow rate.

**Table. Pressure differential needed to satisfy the required flow rate = 0 to 75  $\text{d}/\text{min}$ .**

	$\phi 1.6$	$\phi 2.3$	$\phi 4.0$
Pressure differential ( $\Delta P$ )	0.5 to 0.7 MPa	0.25 to 0.35 MPa	0.12 MPa

$\Delta P = (P_1 - P_2)$  MPa  
 $\Delta P$ : Pressure differential  
 $P_1$ : Inlet pressure  
 $P_2$ : Outlet pressure

### PVQ30 ( $\phi 1.6$ )

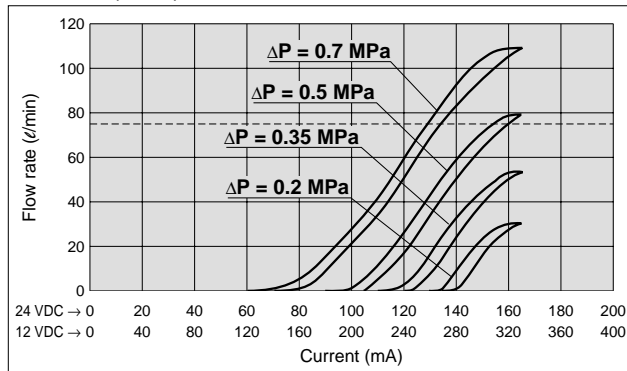

### PVQ30 ( $\phi 2.3$ )

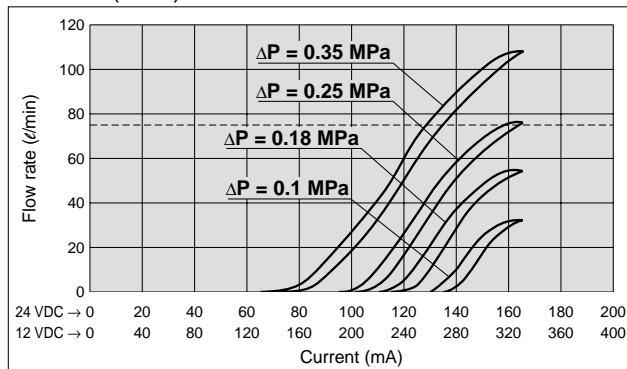

### PVQ30 ( $\phi 4.0$ )

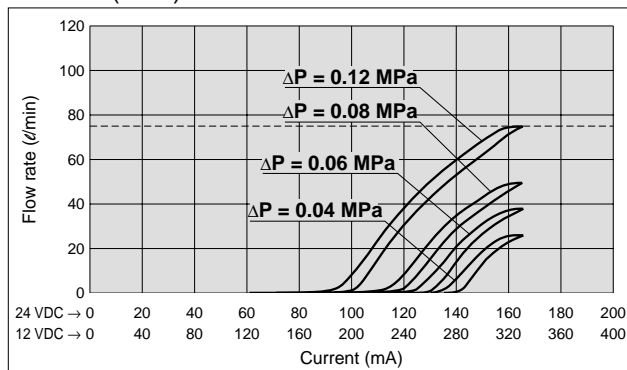

## ● Note

- 1) Follow the same procedure for selecting PVQ10 series.
- 2) Flow rate depends on individual differences between valves and piping conditions. Refer to the flow characteristic chart to select the model with adequate margin for the required flow rate.

# Compact Proportional Solenoid Valve Series PVQ10



## How to Order

Base mounted



PVQ 13 — 5 L — 03 — M5 — A

Valve type  
13 N.C.

Voltage  
5 24 VDC  
6 12 VDC

Electrical entry

L	L plug connector	
M	M plug connector	

With / Without lead wire  
- With lead wire  
O Without lead wire

Body / Seal material

Symbol	Body	Seal
A	Brass (C36)	FKM
H	Stainless steel	FKM

Port size

-	Without sub-plate (with mounting screw M1.7 x 17L, 2 pcs.)	
M5	With sub-plate M5 x 0.8	

Orifice size

Symbol	Orifice dia.	Max. operating pressure
03	0.3 mm $\varnothing$	0.7 MPa
04	0.4 mm $\varnothing$	0.45 MPa
06	0.6 mm $\varnothing$	0.2 MPa
08	0.8 mm $\varnothing$	0.1 MPa

## Specifications

Standard specifications	Valve construction	Direct operated poppet	
	Fluid	Air, Inert gas	
	Seal material	FKM	
	Body material	Brass (C36), Stainless steel	
	Fluid temperature	0 to +50°C	
	Ambient temperature	0 to +50°C	
	Action	N.C. (Normally closed)	
	Mounting orientation	Unrestricted	
	Port size	M5	
	Coil specifications	Power supply	24 VDC
Coil current		0 to 85 mA	0 to 170 mA
Power consumption		0 to 2 W	
Coil insulation		Class B	

Characteristic specifications	Orifice diameter (mm $\varnothing$ )	0.3	0.4	0.6	0.8
	Max. operating pressure differential (MPa) <sup>Note 1)</sup>	0.7	0.45	0.2	0.1
	Max. operating pressure (MPa)	1			
	Min. operating pressure (MPa) (Vacuum) <sup>Note 2)</sup>	0 (0.1 Pa.abs)			
	Flow rate (l/min) (at max. operating pressure differential)	0 to 5	0 to 6		0 to 5
	Hysteresis (at max. operating pressure differential)	10% or less			
	Repeatability (at max. operating pressure differential)	3% or less			
	Start-up current (at max. operating pressure differential)	50% or less			

Note 1) Maximum operating pressure differential indicates pressure differential (difference between the inlet and outlet pressure) which can be allowed for operation with the valve closed or open. If the pressure differential exceeds the max. operating pressure differential of orifice, the valve may leak.

Note 2) For vacuum applications, the max. operating pressure range is 0.1 Pa.abs to max. operating pressure differential. A(2) port is applicable for vacuum pressure.

## Flow Characteristics

**PVQ10 (∅0.3)**

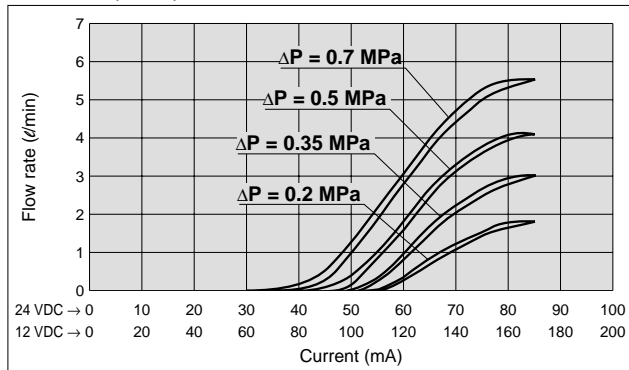

**PVQ10 (∅0.4)**

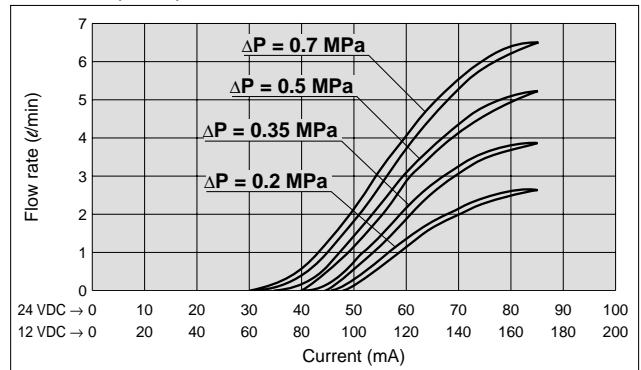

**PVQ10 (∅0.6)**

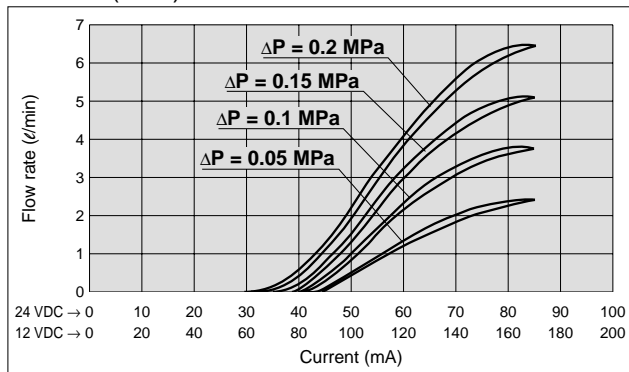

**PVQ10 (∅0.8)**

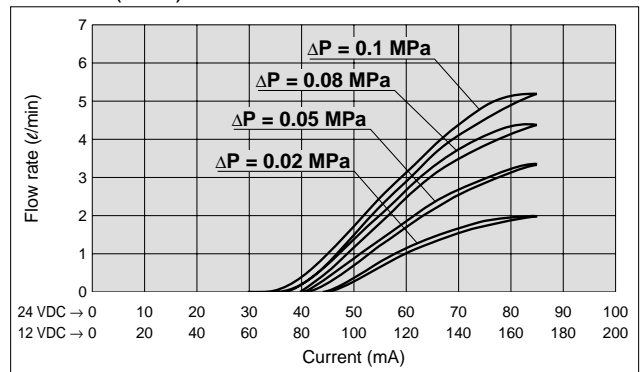

## Construction

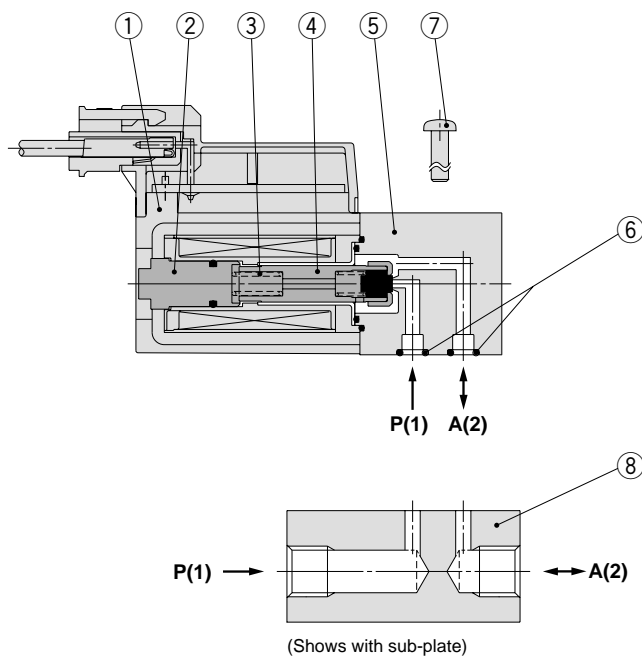

## Component Parts

No.	Description	Material	Note
1	Solenoid coil assembly	—	
2	Core	Stainless steel	
3	Return spring	Stainless steel	
4	Armature assembly	Stainless steel, Aluminium, FKM	
5	Body	Brass (C36)	
6	O-ring	FKM	
7	Round head combination screw	Steel	M1.7 x 0.35 x 17L, 2 pcs.
8	Sub-plate	Brass (C37)	Part no. PVQ10-15-M5

# Series PVQ10

## Dimensions

### L plug connector PVQ13-□L-□-M5

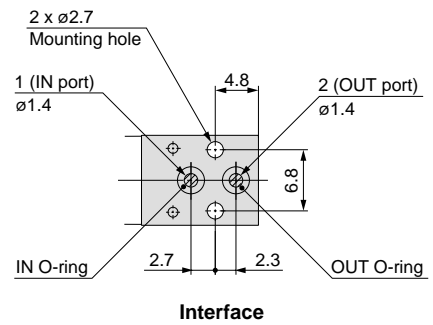
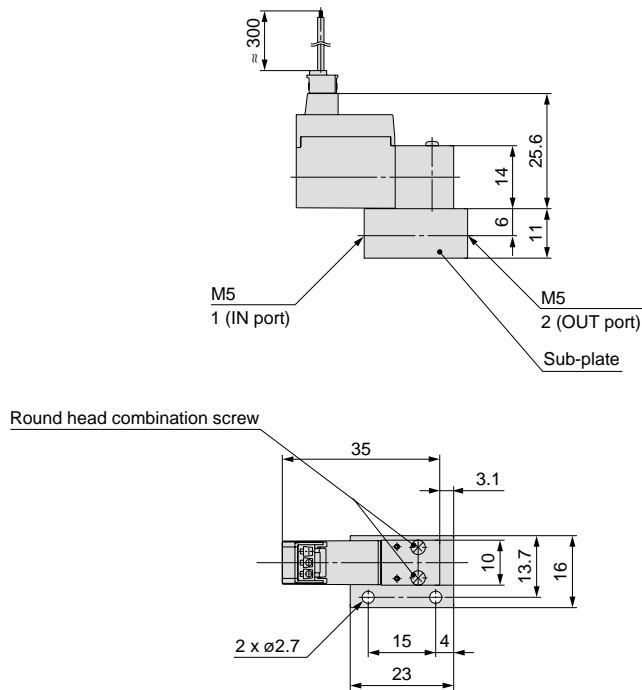

### M plug connector PVQ13-□M-□-M5

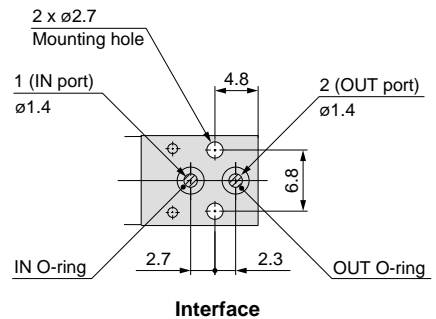
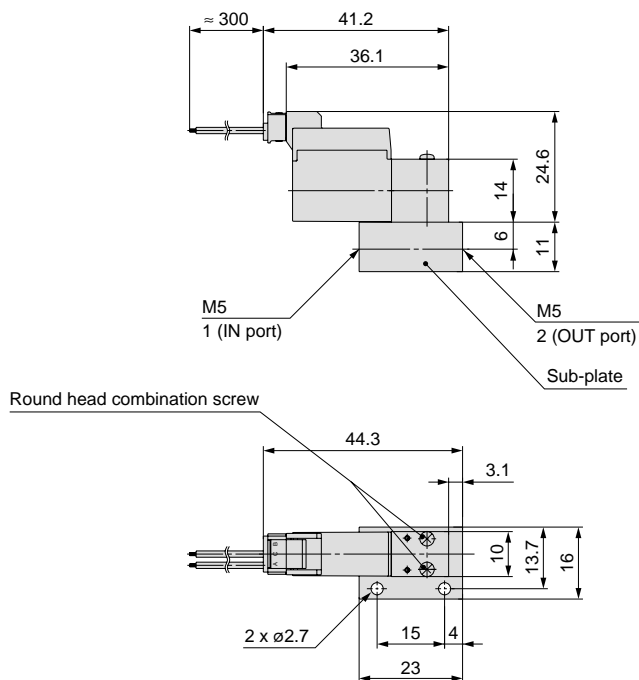



# Compact Proportional Solenoid Valve Series PVQ30



## How to Order

Body ported

Base mounted



**Valve type**

31	N.C.
----	------

**Port size**

01	1/8 (6A)
----	----------

**Option**

-	None
F	Foot bracket

\* Bracket is not mounted but is provided at the time of shipment.

**Body / Seal material**

Symbol	Body	Seal
-	Brass (C37)	FKM
H	Stainless steel	FKM

**Thread type (with sub-plate)**

-	Rc
F	G
N	NPT
T	NPTF

**Valve type**

33	N.C.
----	------

**Voltage**

5	24 VDC
6	12 VDC

**Electrical entry: Grommet**

**Orifice size**

Symbol	Orifice dia.	Max. operating pressure
16	1.6 mmø	0.7 MPa
23	2.3 mmø	0.35 MPa
40	4 mmø	0.12 MPa

**Port size**

-	Without sub-plate (with mounting screw M3 x 8L, 2 pcs.)	
01	With sub-plate 1/8 (6A)	

## Specifications

Standard specifications	Valve construction	Direct operated poppet	
	Fluid	Air, Inert gas	
	Seal material	FKM	
	Body material	Brass (C37, Standard), Stainless steel	
	Fluid temperature	0 to +50°C	
	Ambient temperature	0 to +50°C	
	Action	N.C. (Normally closed)	
	Mounting orientation	Unrestricted	
	Enclosure	IP40	
	Port size	Rc 1/8	
Coil specifications	Power supply	24 VDC	12 VDC
	Coil current	0 to 165 mA	0 to 330 mA
	Power consumption	0 to 4 W	
	Coil insulation	Class B	

Characteristic specifications	Orifice diameter (mmø)	1.6	2.3	4.0
	Max. operating pressure differential (MPa) <small>Note 1)</small>	0.7	0.35	0.12
	Max. operating pressure (MPa)	1		
	Min. operating pressure (MPa) (Vacuum) <small>Note 2)</small>	0 (0.1 Pa.abs)		
	Flow rate (l/min) (at max. operating pressure differential)	0 to 100	0 to 75	
	Hysteresis (at max. operating pressure differential)	10% or less	13% or less	
	Repeatability (at max. operating pressure differential)	3% or less		
	Start-up current (at max. operating pressure differential)	50% or less		

Note 1) Maximum operating pressure differential indicates pressure differential (difference between the inlet and outlet pressure) which can be allowed for operation with the valve closed or open. If the pressure differential exceeds the max. operating pressure differential of orifice, the valve may leak.

Note 2) For vacuum applications, the max. operating pressure range is 0.1 Pa-abs to max. operating pressure differential. A(2) port is applicable for vacuum pressure-

# Series PVQ10

## Flow Characteristics

Air

PVQ30 (ø1.6)

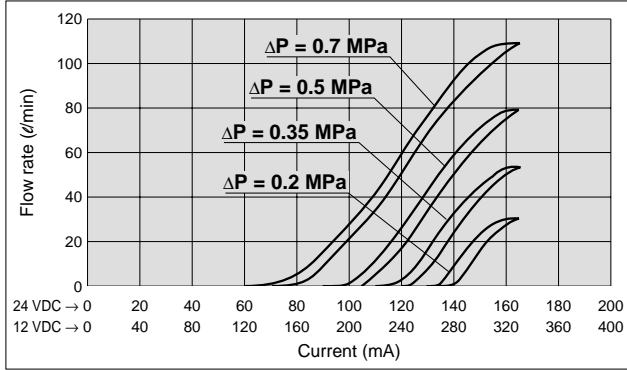

PVQ30 (ø2.3)

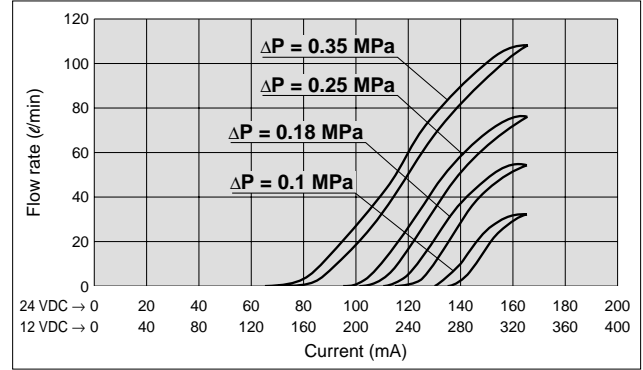

PVQ30 (ø4.0)

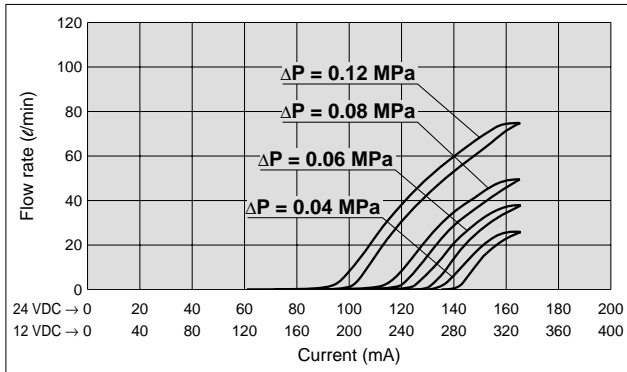

## Construction

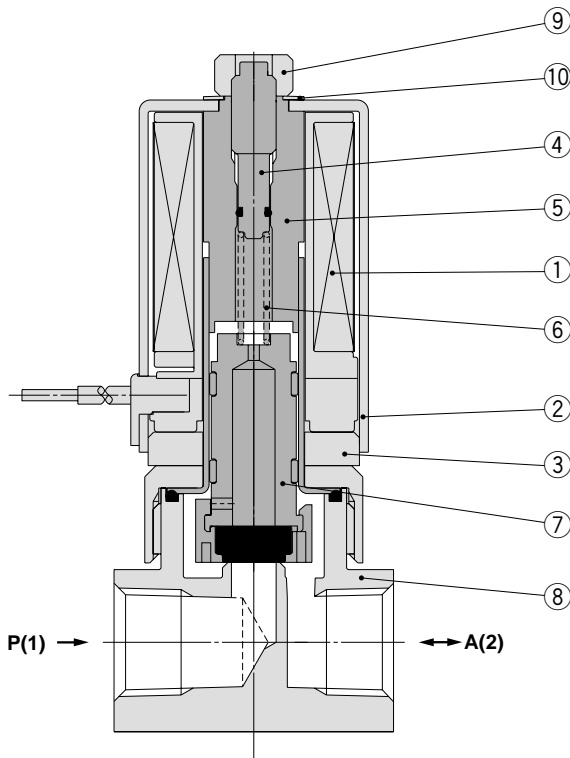

### Component Parts

No.	Description	Material	Note
1	Solenoid coil assembly	—	
2	Coil cover	Steel (SPCE)	
3	Magnetic plate	Magnetic iron (SUY)	
4	Adjusting screw	Stainless steel	
5	Tube assembly	Stainless steel	
6	Return spring	Stainless steel	
7	Armature assembly	Stainless steel, PPS, PTFE, FKM	
8	Body	Brass (C37) or Stainless steel	
9	Nut	Steel	
10	Wave washer	Stainless steel	
11	Round head combination screw	Copper	M3 x 8L, 2 pcs.
12	Sub-plate	Brass (C37)	Part no.: PVQ30-15-01□
13	O-ring	FKM	
14	O-ring	FKM	

Option (Body ported only)

• Bracket assembly: VDW20-15A-1

## Dimensions

### PVQ31

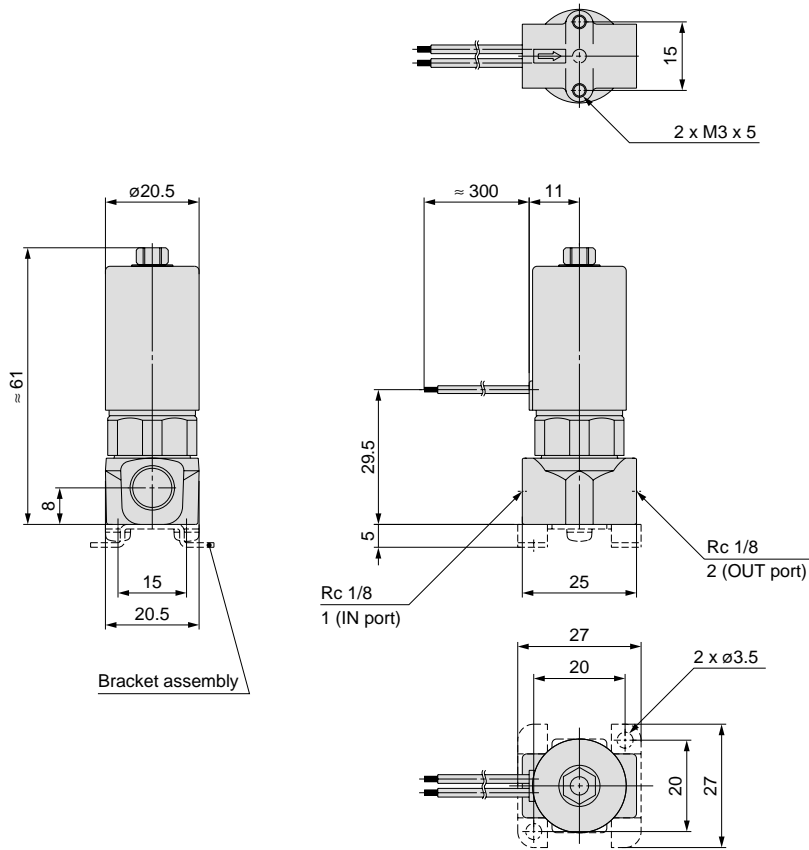

### PVQ33

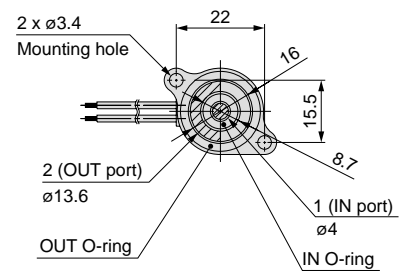
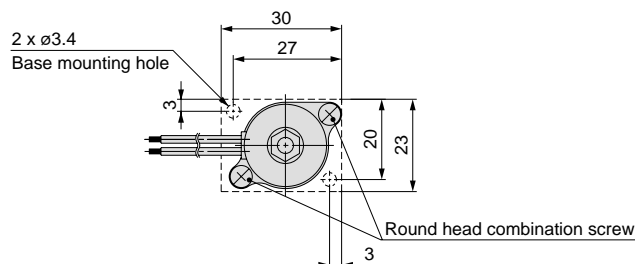
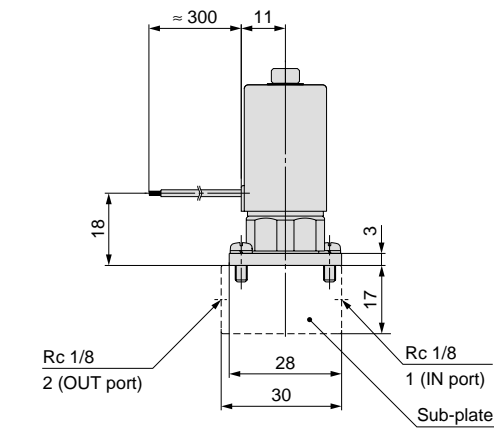
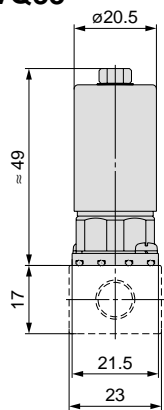

### Interface

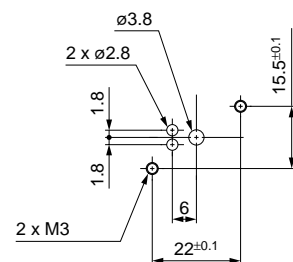

### Machining dimensions of the base

# Glossary

## ■ Proportional control

The fluid is controlled proportionally according to an input signal (current).

## ■ Max. operating pressure differential

Indicates the max. pressure differential (difference between the inlet and the outlet pressure) which is allowed for operation with the valve closed or open.

## ■ Max. operating pressure

Indicates the limit pressure that can be applied to the inlet. (The pressure differential of the proportional valve must be no more than the maximum operating pressure differential)

## ■ Orifice diameter

Diameter of the hole sealing the body of the proportional valve. This does not indicate the effective cross section.

## ■ Hysteresis

Maximum flow rate difference between the current increase and the current decrease (for the same current). (Percentage divided by the max. flow rate)

## ■ Repeatability

Deviation of output flow rate when the same current is applied. (Percentage divided by max. flow rate)

## ■ Start-up current

Current at which the flow rate is actually output when increasing the current from zero. (Percentage divided by the rated current)





Series PVQ

# Safety Instructions

These safety instructions are intended to prevent a hazardous situation and/or equipment damage. These instructions indicate the level of potential hazard by labels of "Caution", "Warning" or "Danger". To ensure safety, be sure to observe ISO 4414 <sup>Note 1)</sup>, JIS B 8370 <sup>Note 2)</sup> and other safety practices.

## ■ Explanation of the Labels

Labels	Explanation of the labels
 <b>Danger</b>	In extreme conditions, there is a possible result of serious injury or loss of life.
 <b>Warning</b>	Operator error could result in serious injury or loss of life.
 <b>Caution</b>	Operator error could result in injury <sup>Note 3)</sup> or equipment damage. <sup>Note 4)</sup>

Note 1) ISO 4414: Pneumatic fluid power – General rules relating to systems

Note 2) JIS B 8370: General Rules for Pneumatic Equipment

Note 3) Injury indicates light wounds, burns and electrical shocks that do not require hospitalization or hospital visits for long-term medical treatment.

Note 4) Equipment damage refers to extensive damage to the equipment and surrounding devices.

## ■ Selection/Handling/Applications

### 1. The compatibility of the pneumatic equipment is the responsibility of the person who designs the pneumatic system or decides its specifications.

Since the products specified here are used in various operating conditions, their compatibility for the specific pneumatic system must be based on specifications or post analysis and/or tests to meet the specific requirements. The expected performance and safety assurance are the responsibility of the person who has determined the compatibility of the system. This person should continuously review the suitability of all items specified, referring to the latest catalogue information with a view to giving due consideration to any possibility of equipment failure when configuring a system.

### 2. Only trained personnel should operate pneumatically operated machinery and equipment.

Fluids can be dangerous if handled incorrectly. Assembly, handling or repair of the systems using pneumatic equipment should be performed by trained and experienced operators.

### 3. Do not service machinery/equipment or attempt to remove components until safety is confirmed.

1. Inspection and maintenance of machinery/equipment should only be performed once measures to prevent falling or runaway of the driven objects have been confirmed.
2. When equipment is removed, confirm the safety process as mentioned above. Turn off the supply pressure for this equipment and exhaust all residual compressed air in the system.
3. Carefully restart the machinery, confirming that safety measures are being implemented.

### 4. Contact SMC if the product will be used in any of the following conditions:

1. Conditions and environments beyond the given specifications, or if product is used outdoors.
2. With fluids whose application causes concern due to the type of fluid or additives, etc.
3. An application which has the possibility of having negative effects on people and/or property, requiring special safety analysis.

## ■ Exemption from Liability

1. SMC, its officers and employees shall be exempted from liability for any loss or damage arising out of earthquakes or fire, action by a third person, accidents, customer error with or without intention, product misuse, and any other damages caused by abnormal operating conditions.

2. SMC, its officers and employees shall be exempted from liability for any direct or indirect loss or damage, including consequential loss or damage, loss of profits, or loss of chance, claims, demands, proceedings, costs, expenses, awards, judgments and any other liability whatsoever including legal costs and expenses, which may be suffered or incurred, whether in tort (including negligence), contract, breach of statutory duty, equity or otherwise.

3. SMC is exempted from liability for any damages caused by operations not contained in the catalogues and/or instruction manuals, and operations outside of the specification range.

4. SMC is exempted from liability for any loss or damage whatsoever caused by malfunctions of its products when combined with other devices or software.



# 2/3 Port Process Valves Precautions 1

Be sure to read this before handling.

For detailed precautions on every series, refer to main text.

## Design

### Warning

#### 1. Cannot be used as an emergency shutoff valve, etc.

The valves presented in this catalog are not designed for safety applications such as an emergency shutoff valve. If the valves are used in this type of system, other reliable safety assurance measures should also be adopted.

#### 2. Extended periods of continuous energisation

Please consult SMC when using with energisation for long periods of time.

#### 3. This solenoid valve cannot be used for explosion proof applications.

#### 4. Maintenance space

The installation should allow sufficient space for maintenance activities (removal of the valve, etc.).

#### 5. Actuator drive

When an actuator, such as a cylinder, is to be driven using a valve, take appropriate measures to prevent potential danger caused by actuator operation.

#### 6. Pressure (including vacuum) holding

It is not usable for applications such as holding the pressure (including vacuum) inside of a pressure vessel because air leakage is entailed in the valve.

## Selection

### Warning

#### 1. Confirm the specifications.

Give careful consideration to the operating conditions such as the application, fluid and environment, and use within the operating ranges specified in this catalogue.

#### 2. Fluid

##### 1) Gas

Refer to specification for internal/external leakage.

##### 2) Corrosive gas

Cannot be used since it will lead to cracks by stress corrosion or result in other incidents.

#### 3. Fluid quality

The use of a fluid which contains foreign matter can cause malfunction and seal failure. These problems are due to wear of the valve seat and armature, and sticking to the sliding parts of the armature. Install a suitable filter (strainer) immediately upstream from the valve. As a general rule, use 80 to 100 mesh.

## Selection

### Warning

#### 4. Air quality

##### 1) Use clean air.

Do not use compressed air which includes chemicals, synthetic oils containing organic solvents, salt or corrosive gases, etc., as it can cause damage or malfunction.

##### 2) Install air filters.

Install air filters close to the valves at their upstream side. A nominal filtration rating of 5 µm or less should be selected.

##### 3) Install an air dryer or after-cooler, etc.

Compressed air that includes excessive drainage may cause malfunction of the valves and other pneumatic equipment. To prevent this, install an air dryer or after-cooler, etc.

##### 4) If excessive carbon powder is generated, eliminate it by installing mist separators at the upstream side of the valves.

If excessive carbon powder is generated by the compressor, it may adhere to the inside of the valves and cause a malfunction.

Refer to SMC's "Best Pneumatics" catalogue for further details on compressed air quality.

#### 5. Ambient environment

Use within the operable ambient temperature range. Confirm the compatibility between the product's composition materials and the ambient atmosphere. Be sure that the used fluid does not touch the external surface of the product.

#### 6. Countermeasures against static electricity

Take actions to prevent static electricity since some fluids may cause static electricity.

### Caution

#### 1. Leakage voltage

Particularly when using a resistor in parallel with a switching element and using a C-R element (surge voltage suppressor) to protect the switching element, take note that leakage current will flow through the resistor, C-R element, etc., creating a possible danger that the valve may not turn off.

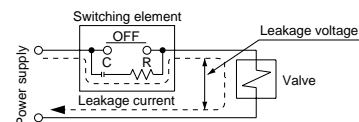

DC coil: 2% or less of rated voltage



# 2/3 Port Process Valves Precautions 2

Be sure to read this before handling.

For detailed precautions on every series, refer to main text.

## Mounting

### Warning

1. If air leakage increases or the equipment does not operate properly, stop operation.

After mounting is completed, confirm that it has been done correctly by performing a suitable function test.

2. Do not apply external forces to the coil section.

When tightening is performed, apply a wrench or other tool to the outside of the piping connection parts.

3. Do not warm the coil assembly with a heat insulator, etc.

Use tape, heaters, etc., to prevent freezing on the piping and body only. They can cause the coil to burn out.

4. Secure with brackets, except in the case of steel piping and copper fittings.

5. Avoid sources of vibration or adjust the arm from the body to the minimum length so that resonance will not occur.

6. Instruction manual

The product should be mounted and operated after the instruction manual is thoroughly read and its contents are understood. Keep the instruction manual where it can be referred to as needed.

7. Painting and coating

Warnings or specifications printed or labeled on the product should not be erased, removed or covered up.

## Piping

### Caution

1. Preparation before piping

Before piping is connected, it should be thoroughly blown out with air (flushing) or washed to remove chips, cutting oil and other debris from inside the pipe.

Avoid pulling, compressing or bending the valve body when piping.

2. Wrapping of pipe tape

When connecting pipes, fittings, etc., be sure that chips from the pipe threads and sealing material do not enter the valve.

Furthermore, when pipe tape is used, leave 1.5 to 2 thread ridges exposed at the end of the threads.

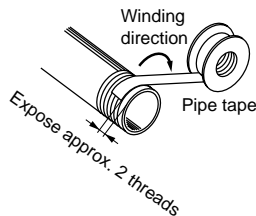

3. Avoid connecting ground lines to piping, as this may cause electric corrosion of the system.

## Piping

### Caution

4. Always tighten threads with the proper tightening torque.

When attaching fittings to valves, tighten with the proper tightening torque shown below.

#### Tightening Torque for Piping

Connection threads	Proper tightening torque N·m
M5	1.5 to 2
Rc 1/8	7 to 9

\* Reference

Tightening of M5 fitting threads

After tightening by hand, tighten approximately 1/6 turn further with a tightening tool. However, when using miniature fittings, tighten an additional 1/4 turn after tightening by hand. (In cases where there are gaskets in two places, such as a universal elbow or universal tee, double the additional tightening to 1/2 turn.)

5. Connection of piping to products

When connecting piping to a product, refer to its instruction manual to avoid mistakes regarding the supply port, etc.

## Wiring

### Caution

1. As a rule, use electrical wire with a cross sectional area of 0.5 to 1.25 mm<sup>2</sup> for wiring.

Furthermore, do not allow excessive force to be applied to the lines.

2. Use electrical circuits which do not generate chattering in their contacts.

3. Use voltage which is within  $\pm 10\%$  of the rated voltage.

When using a DC power supply where importance is placed on responsiveness, stay within  $\pm 5\%$  of the rated value. The voltage drop is the value in the lead wire section connecting the coil.

4. When a surge from the solenoid affects the electrical circuitry, install a surge absorber, etc., in parallel with the solenoid.



# 2/3 Port Process Valves Precautions 3

Be sure to read this before handling.  
For detailed precautions on every series, refer to main text.

## Operating Environment

### Warning

1. Do not use the valves in an atmospheres having corrosive gases, chemicals, salt water, water, steam, or where there is direct contact with any of these.
2. Do not use in explosive atmospheres.
3. Do not use in locations subject to vibration or impact.
4. Do not use in locations where radiated heat will be received from nearby heat sources.
5. Employ suitable protective measures in locations where there is contact with water droplets, oil or welding spatter, etc.

## Lubrication

### Caution

1. This solenoid valve can be operated without lubrication.

If a lubricant is used in the system, use turbine oil Class 1, ISO VG32 (with no additives).

In order to select the proper lubricant, refer to the table below [Brand names of Class 1 turbine oils (With no additives) compliant with ISO VG32].

#### Class 1 Turbine Oil (with no additive), ISO VG32

Classification of viscosity (cst) (40°C)	Viscosity according to ISO Grade	32
Idemitsu Kosan Co.,Ltd.		Turbine oil P-32
Nippon Oil Corp.		Turbine oil 32
Cosmo Oil Co.,Ltd.		Cosmo turbine 32
Japan Energy Corp.		Kyodo turbine 32
Kygnus Oil Co.		Turbine oil 32
Kyushu Oil Co.		Stork turbine 32
Nippon Oil Corp.		Mitsubishi turbine 32
Showa Shell Sekiyu K.K.		Turbine 32
Tonen General Sekiyu K.K.		General R turbine 32
Fuji Kosan Co.,Ltd.		Fucoal turbine 32

Please contact SMC regarding Class 2 turbine oil (with additives), ISO VG32.

## Maintenance

### Warning

1. Removing the product
  1. Shut the fluid supply off and release the fluid pressure in the system.
  2. Shut the power supply off.
  3. Dismount the product.
2. Low frequency operation  
Switch valves at least once every 30 days to prevent malfunction. Also, in order to use it under the optimum state, conduct a regular inspection every 6 months.
3. Do not disassemble the product. Products which have been disassembled cannot be guaranteed.  
If disassembly is necessary, please contact SMC.

### Caution

1. Filters and strainers
  1. Be careful regarding clogging of filters and strainers.
  2. Replace filter elements after one year of use, or earlier if the pressure drop reaches 0.1 MPa.
  3. Clean strainers when the pressure drop reaches 0.1 MPa.
2. Exhaust the drain from an air filter periodically.





# Series PVQ Specific Product Precautions

Be sure to read this before handling.

## Power Source Selection

### ⚠ Caution

**This product makes proportional control possible with constant current.**

If controlled with voltage, the output flow rate cannot be kept constant due to current fluctuation. Use a stable DC power source with sufficient capacity without much ripple.

## Handling

### ⚠ Caution

**1. This product is adjusted to the respective specifications at the SMC factory before delivery.**

Do not disassemble the product or remove parts as it could cause breakdown of the product.

**2. Flow rate is controlled by balancing the valve body.**

Do not expose the product to external vibration and impact as they change the flow rate.

## Pressure Difference

### ⚠ Caution

**Leakage from the valve may be caused if the pressure difference is larger than the maximum operating pressure differential of the respective models.**

## Operation in Vacuum

### ⚠ Caution

**When the product is used in vacuum, apply vacuum pressure to A (2) port.**

Pressure at P(1) port should be larger than the pressure at A(2) port.

## Valve Mounting

### ⚠ Caution

**When mounting a valve to the sub-plate, tighten the screw securely with the tightening torque shown in the table below after checking the installation condition of the O-ring on the interface side.**

#### Proper Tightening Torque (N·m)

PVQ10 (Base mounted)	PVQ30 (Base mounted)
0.15 to 0.22	0.8 to 1.0

## Continuous Energisation

### ⚠ Warning

**Do not touch the valve directly. The coil can be hot depending on the ambient temperature or energising time.**

Install a protective cover over the valve if it can be touched directly.







## EUROPEAN SUBSIDIARIES:



### Austria

SMC Pneumatik GmbH (Austria).  
Girakstrasse 8, A-2100 Korneuburg  
Phone: +43 2262-62280, Fax: +43 2262-62285  
E-mail: [office@smc.at](mailto:office@smc.at)  
<http://www.smc.at>



### France

SMC Pneumatique, S.A.  
1, Boulevard de Strasbourg, Parc Gustave Eiffel  
Bussy Saint Georges F-77607 Marne La Vallée Cedex 3  
Phone: +33 (0)1-6476 1000, Fax: +33 (0)1-6476 1010  
E-mail: [contact@smc-france.fr](mailto:contact@smc-france.fr)  
<http://www.smc-france.fr>



### Netherlands

SMC Pneumatics BV  
De Ruyterkade 120, NL-1011 AB Amsterdam  
Phone: +31 (0)20-5318888, Fax: +31 (0)20-5318880  
E-mail: [info@smcpneumatics.nl](mailto:info@smcpneumatics.nl)  
<http://www.smcpneumatics.nl>



### Spain

SMC España, S.A.  
Zuazobidea 14, 01015 Vitoria  
Phone: +34 945-184 100, Fax: +34 945-184 124  
E-mail: [post@smcsmces.es](mailto:post@smcsmces.es)  
<http://www.smc.es>



### Belgium

SMC Pneumatics N.V./S.A.  
Nijverheidsstraat 20, B-2160 Wommelgem  
Phone: +32 (0)3-355-1464, Fax: +32 (0)3-355-1466  
E-mail: [post@smcpneumatics.be](mailto:post@smcpneumatics.be)  
<http://www.smcpneumatics.be>



### Germany

SMC Pneumatik GmbH  
Boschring 13-15, D-63329 Egelsbach  
Phone: +49 (0)6103-4020, Fax: +49 (0)6103-402139  
E-mail: [info@smc-pneumatik.de](mailto:info@smc-pneumatik.de)  
<http://www.smc-pneumatik.de>



### Norway

SMC Pneumatics Norway A/S  
Vollsvæien 13 C, Granfos Næringspark N-1366 Lysaker  
Phone: +47 67 12 90 20, Fax: +47 67 12 90 21  
E-mail: [post@smc-norge.no](mailto:post@smc-norge.no)  
<http://www.smc-norge.no>



### Sweden

SMC Pneumatics Sweden AB  
Ekhagsvägen 29-31, S-141 71 Huddinge  
Phone: +46 (0)8-603 12 00, Fax: +46 (0)8-603 12 90  
E-mail: [post@smcpneumatics.se](mailto:post@smcpneumatics.se)  
<http://www.smc.nu>



### Bulgaria

SMC Industrial Automation Bulgaria EOOD  
16 Kliment Ohridski Blvd., fl.13 BG-1756 Sofia  
Phone: +359 2 9744492, Fax: +359 2 9744519  
E-mail: [office@smc.bg](mailto:office@smc.bg)  
<http://www.smc.bg>



### Greece

SMC Hellas EPE  
Anageniseos 7-9 - P.C. 14342, N. Philadelphia, Athens  
Phone: +30-210-2717265, Fax: +30-210-2717766  
E-mail: [sales@smchellas.gr](mailto:sales@smchellas.gr)  
<http://www.smchellas.gr>



### Poland

SMC Industrial Automation Polska Sp.z o.o.  
ul. Poloneza 89, PL-02-826 Warszawa,  
Phone: +48 22 211 9600, Fax: +48 22 211 9617  
E-mail: [office@smc.pl](mailto:office@smc.pl)  
<http://www.smc.pl>



### Switzerland

SMC Pneumatik AG  
Dorfstrasse 7, CH-8484 Weisslingen  
Phone: +41 (0)52-396-3131, Fax: +41 (0)52-396-3191  
E-mail: [info@smc.ch](mailto:info@smc.ch)  
<http://www.smc.ch>



### Croatia

SMC Industrijska automatika d.o.o.  
Cromerac 12, 10000 ZAGREB  
Phone: +385 1 377 66 74, Fax: +385 1 377 66 74  
E-mail: [office@smc.hr](mailto:office@smc.hr)  
<http://www.smc.hr>



### Hungary

SMC Hungary Ipari Automatizálási Kft.  
Budafoki út 107-113, H-1117 Budapest  
Phone: +36 1 371 1343, Fax: +36 1 371 1344  
E-mail: [office@smc.hu](mailto:office@smc.hu)  
<http://www.smc.hu>



### Portugal

SMC Sucursal Portugal, S.A.  
Rua de Engº Ferreira Dias 452, 4100-246 Porto  
Phone: +351 22-610-89-22, Fax: +351 22-610-89-36  
E-mail: [post@pt@smc.smces.es](mailto:post@pt@smc.smces.es)  
<http://www.smces.es>



### Turkey

Entek Pnömatik San. ve Tic Ltd. Sti.  
Peşpa Tic. Merkezi Kat: 11 No: 1625, TR-80270 Okmeydanı Istanbul  
Phone: +90 (0)212-221-1512, Fax: +90 (0)212-221-1519  
E-mail: [smc-entek@entek.com.tr](mailto:smc-entek@entek.com.tr)  
<http://www.entek.com.tr>



### Czech Republic

SMC Industrial Automation CZ s.r.o.  
Hudcova 78a, CZ-61200 Brno  
Phone: +420 5 414 24611, Fax: +420 5 412 18034  
E-mail: [office@smc.cz](mailto:office@smc.cz)  
<http://www.smc.cz>



### Ireland

SMC Pneumatics (Ireland) Ltd.  
2002 Citywest Business Campus, Naas Road, Saggart, Co. Dublin  
Phone: +353 (0)1-403 9000, Fax: +353 (0)1-464-0500  
E-mail: [sales@smcpneumatics.ie](mailto:sales@smcpneumatics.ie)  
<http://www.smcpneumatics.ie>



### Romania

SMC Romania srl  
Str Frunzei 29, Sector 2, Bucharest  
Phone: +40 213205111, Fax: +40 213261489  
E-mail: [smcromania@smcromania.ro](mailto:smcromania@smcromania.ro)  
<http://www.smcromania.ro>



### UK

SMC Pneumatics (UK) Ltd  
Vincent Avenue, Crownhill, Milton Keynes, MK8 0AN  
Phone: +44 (0)800 1382930 Fax: +44 (0)1908-555064  
E-mail: [sales@smcpneumatics.co.uk](mailto:sales@smcpneumatics.co.uk)  
<http://www.smcpneumatics.co.uk>



### Denmark

SMC Pneumatik A/S  
Knudsmide 4B, DK-8300 Odder  
Phone: +45 70252900, Fax: +45 70252901  
E-mail: [smc@smc-pneumatik.dk](mailto:smc@smc-pneumatik.dk)  
<http://www.smc.dk>



### Italy

SMC Italia S.p.A  
Via Garibaldi 62, I-20061 Carugate, (Milano)  
Phone: +39 (0)2-92711, Fax: +39 (0)2-9271365  
E-mail: [mailbox@smcitalia.it](mailto:mailbox@smcitalia.it)  
<http://www.smcitalia.it>



### Russia

SMC Pneumatik LLC.  
4B Sverdlovskaja nab, St. Petersburg 195009  
Phone: +7 812 718 5445, Fax: +7 812 718 5449  
E-mail: [info@smc-pneumatik.ru](mailto:info@smc-pneumatik.ru)  
<http://www.smc-pneumatik.ru>



### Estonia

SMC Pneumatics Estonia OÜ  
Laki 12, 106 21 Tallinn  
Phone: +372 6510370, Fax: +372 6510371  
E-mail: [smc@smcpneumatics.ee](mailto:smc@smcpneumatics.ee)  
<http://www.smcpneumatics.ee>



### Latvia

SMC Pneumatics Latvia SIA  
Smerla 1-705, Riga LV-1006  
Phone: +371 781-77-00, Fax: +371 781-77-01  
E-mail: [info@smclv.lv](mailto:info@smclv.lv)  
<http://www.smclv.lv>



### Slovakia

SMC Priemyselna Automatizácia, s.r.o.  
Námestie Matina Benku 10, SK-81107 Bratislava  
Phone: +421 2 444 56725, Fax: +421 2 444 56028  
E-mail: [office@smc.sk](mailto:office@smc.sk)  
<http://www.smc.sk>



### Finland

SMC Pneumatics Finland Oy  
PL72, Tiistinniityntie 4, SF-02231 ESPOO  
Phone: +358 207 513513, Fax: +358 207 513595  
E-mail: [smcfin@smc.fi](mailto:smcfin@smc.fi)  
<http://www.smc.fi>



### Lithuania

SMC Pneumatics Lietuva, UAB  
Oslo g.1, LT-04123 Vilnius  
Phone: +370 5 264 81 26, Fax: +370 5 264 81 26



### Slovenia

SMC industrijska Avtomatika d.o.o.  
Mirnska cesta 7, SLO-8210 Trebnje  
Phone: +386 7 3885412 Fax: +386 7 3885435  
E-mail: [office@smc.si](mailto:office@smc.si)  
<http://www.smc.si>



## OTHER SUBSIDIARIES WORLDWIDE:

ARGENTINA, AUSTRALIA, BOLIVIA, BRASIL, CANADA, CHILE,  
CHINA, HONG KONG, INDIA, INDONESIA, MALAYSIA, MEXICO,  
NEW ZEALAND, PHILIPPINES, SINGAPORE, SOUTH KOREA,  
TAIWAN, THAILAND, USA, VENEZUELA

<http://www.smceu.com>  
<http://www.smcworld.com>