

# Compact Direct Operated 2/3 Port Solenoid Valve for Chemicals



★ Wetted part material:

Body/Plate

**PEEK**

Diaphragm

Choice of

**EPDM, FKM, Kalrez®** Note)

★ Service life: **10 million cycles** or more  
(Based on SMC test conditions)

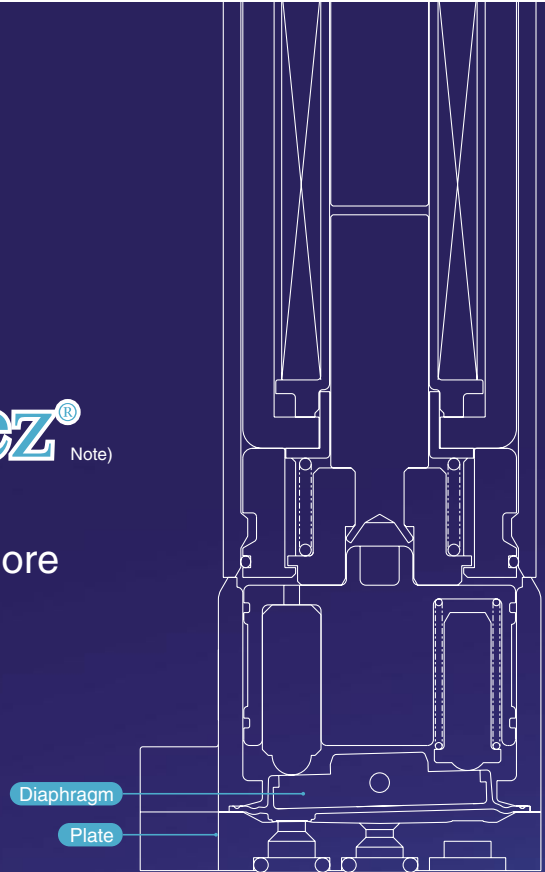

*More variations!*

**New**

Orifice diameter  
**1.1 mm**



LVM09/090

Orifice diameter  
**1.4 mm**



LVM10/100

**New**

Orifice diameter  
**1.6 mm**



LVM15/150

**New**

Orifice diameter  
**2 mm**



LVM20/200

Note) Kalrez® is a registered trademark of DuPont Performance Elastomers.

**Series LVM**

**SMC**  
CAT.EUS70-30B-UK

# Meeting the most advanced needs of process control

## Compact Direct Operated 2/3 Port

### ○ Valve chamber volume

Unit:  $\mu\text{l}$

Series	LVM09/090	LVM10 (For LVM11)	LVM10/100	LVM15/150	LVM20/200
Valve chamber volume	18	11	20	50	84

### ○ Change in volume depending on the open/closed status of the valve (pumping volume)

## 0.01 $\mu\text{l}$ or less (Rocker type)

“Pumping volume” refers to the volume of water that is expelled from the valve chamber by the opening and closing action of the valve (once, with no applied pressure).

With a normal diaphragm valve, because the valve chamber volume varies depending on the ON or OFF status, a difference in volume is discharged into the outlet side of the valve when the valve is switched from ON to OFF. However, with a rocker type valve, there is almost no change in volume, thus no fluid is discharged into the outlet side of the valve.

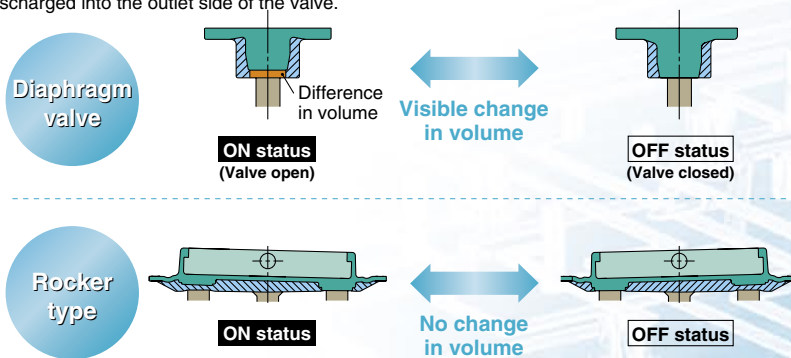

### ○ Type with power-saving circuit can be selected.

Holding power consumption can be reduced substantially.

Unit: W

Series		LVM09/090	LVM10/100	LVM15/150	LVM20/200
Power consumption	Inrush	3.3	2.5	5.5	4
	Holding	0.9	1	1	0.6

### ○ Space-saving

Unit: mm

Series	LVM090	LVM10/100	LVM150	LVM200
Valve width	9.5	13	16	20
Manifold pitch	10.5	14	17	21

Refer to 10 in “Design and Selection” on back page 2 if the valve is to be energised continuously for extended periods of time, or used with a manifold.

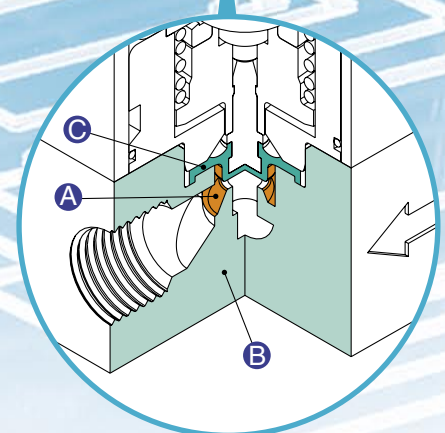
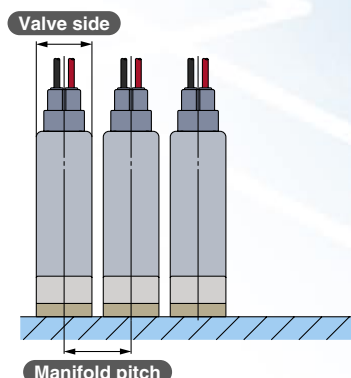

LVM11

### ○ Applications: Various analytical and inspection equipment

Analytical instruments for blood, urine, immune system, etc.

# Solenoid Valve for Chemicals

## Piping/Mounting Variations

### Body ported

- M5 thread

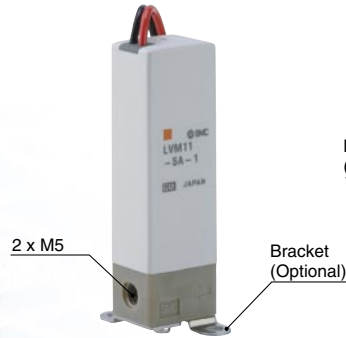

LVM11

- Tubing type

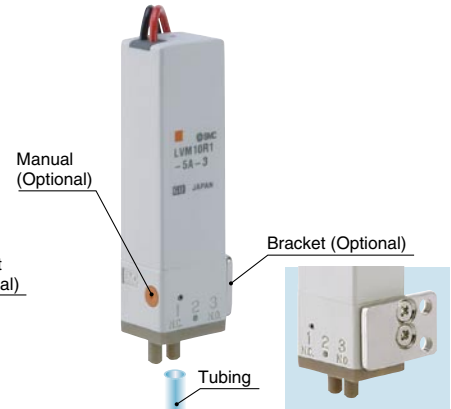

LVM10/100

### Base mounted

- Without sub-plate



LVM09/090

LVM10/100

LVM15/150

LVM20/200

- With sub-plate



LVM10/100



LVM□□□  
(Rocker type)

- A** Valve chamber volume
- B** Body/Plate material: PEEK
- C** Diaphragm material: EPDM, FKM or Kalrez®

PAT.PEND

# Series Variations

	Model	Valve construction	Valve type	Number of ports	Operating pressure range	Orifice diameter (mm)	Valve width		
	LVM09R3	Diaphragm type direct operated poppet (Rocker type)	N.C.	2	-75 kPa to 0.2 MPa	1.1	9.5		
	LVM09R4		N.O.						
	LVM095R		Universal	3					
	LVM11	Diaphragm type direct operated poppet	N.C.	2	0 to 0.25 MPa	1.5	13		
	LVM10R1	Diaphragm type direct operated poppet (Rocker type)	N.C.	2	-75 kPa to 0.25 MPa	1.4	13		
	LVM10R2		N.O.						
	LVM102R		Universal	3					
	LVM10R3		Diaphragm type direct operated poppet (Rocker type)	N.C.	2	-75 kPa to 0.25 MPa	1.4	13	
	LVM10R4			N.O.					
	LVM10R6			N.C.					
	LVM105R	Universal		3					
	LVM15R3	Diaphragm type direct operated poppet (Rocker type)	N.C.	2	-75 kPa to 0.25 MPa (0 to 0.6 MPa)	1.6 (1)	16		
	LVM15R4		N.O.						
	LVM155R		Universal	3					
	LVM20R3	Diaphragm type direct operated poppet (Rocker type)	N.C.	2	-75 kPa to 0.3 MPa	2	20		
	LVM20R4		N.O.						
	LVM205R		Universal	3					

# Series LVM

	Flow characteristics				Fluid temperature (°C)	Volume of valve chamber	Weight (g)	Power consumption (W)	Page
	Water		Air						
	Av	Cv	C	b					
	0.43 x 10 <sup>-6</sup>	0.018	0.06	0.2	0 to 50 (with no condensation)	18	20	2	P.1 to 3
	0.96 x 10 <sup>-6</sup>	0.04	0.13	0.22		11	30	2.5 at inrush 1 at holding	P.4 to 8
	0.72 x 10 <sup>-6</sup>	0.03	0.1	0.2		20	34	1.5	P.4 to 10
	0.72 x 10 <sup>-6</sup>	0.03	0.1	0.2		20	34	1.5	
	0.96 x 10 <sup>-6</sup> (0.36 x 10 <sup>-6</sup> )	0.04 (0.015)	0.13 (0.05)	0.22 (0.2)		50	45	5.5 at inrush 1 at holding	P.11 to 13
	1.56 x 10 <sup>-6</sup>	0.065	0.23	0.27		84	80	2.5	P.14 to 16

\* The values for Av and Cv are based on JIS B 2005:1995, C and b are based on JIB B 8390:2000.

The figures in ( ) indicate high-pressure type.

# Compact Direct Operated 2/3 Port Solenoid Valve for Chemicals Series *LVM09/090*

## How to Order

**Base Mounted** LVM **09R3** **5** **A** **Q**



Symbol	Number of ports	Valve type	
09R3	2	N.C.	
		N.O.	
095R	3	Universal	

### Lead wire length

-	150 mm
3	300 mm
6	600 mm

\* "-" cannot be selected in the case of function Y1.

### Wetted part material

Symbol	Plate	Diaphragm
A	PEEK	EPDM
B	PEEK	FKM
C	PEEK	Kalrez®

### Coil voltage

Symbol	Voltage
5	24 VDC
6	12 VDC

### Function

-	Standard
Y1	With power-saving circuit

## Specifications

Model	Base mounted		
	LVM09R3	LVM09R4	LVM095R
Valve construction	Diaphragm type direct operated poppet (Rocker type)		
Valve type	N.C.	N.O.	Universal
Number of ports	2		3
Fluid <sup>Note 1)</sup>	Air, Water, Pure water, Diluent, Cleaning solvent		
Operating pressure range	-75 kPa to 0.2 MPa		
Orifice diameter	1.1 mm		
Response time	10 ms or less (at pneumatic pressure)		
Leakage	Zero leakage, either external or internal (at water pressure)		
Proof pressure <sup>Note 2)</sup>	0.3 MPa		
Ambient temperature	0 to 50°C		
Fluid temperature	0 to 50°C (with no condensation)		
Volume of valve chamber <sup>Note 3)</sup>	18 μℓ		
Mounting orientation <sup>Note 4)</sup>	Free		
Enclosure	IP40 or equivalent		
Weight	20 g		
Rated voltage	12, 24 VDC		
Allowable voltage fluctuation <sup>Note 5)</sup>	±10% of rated voltage		
Type of coil insulation	Class B		
Power consumption (When rated voltage is at 24 V)	Standard	2 W (0.08 A)	
	With power-saving circuit	Inrush	3.3 W (0.14 A)
		Holding	0.9 W
Coil switching noise <sup>Note 6)</sup>	50 dB		

Note 1) Select an appropriate material for the wetted part when fluids such as a cleaning solvents are used. Also, be sure to confirm the fluid compatibility in advance.

Note 2) Indicates the pressure which does not generate breakage, cracks or external leakage after a one-minute airtight test.

Note 3) Indicates the volume of clearance inside the valve chamber after the volume of the diaphragm is subtracted.

Note 4) Since the body (orifice shape) is designed to eliminate residual liquid, mounting in a vertical direction with the coil at the top is recommended. When residual liquid is not considered, any mounting orientation is available.

Note 5) When the response speed is regarded as important, prevent negative fluctuation of the voltage by adequate regulation.

Note 6) The value is based on SMC's measurement conditions. The noise level will vary with conditions.

Note 7) Refer to 10 in "Design and Selection" on back page 2 if the valve is to be energised continuously for extended periods of time.

## Flow Characteristics

Water		Air	
Av	Cv	C	b
0.43 x 10 <sup>-6</sup>	0.018	0.06	0.2

\* The values for Av and Cv are based on JIS B 2005:1995, C and b are based on JIB B 8390:2000.

**Construction: Base Mounted**

**LVM09R3**

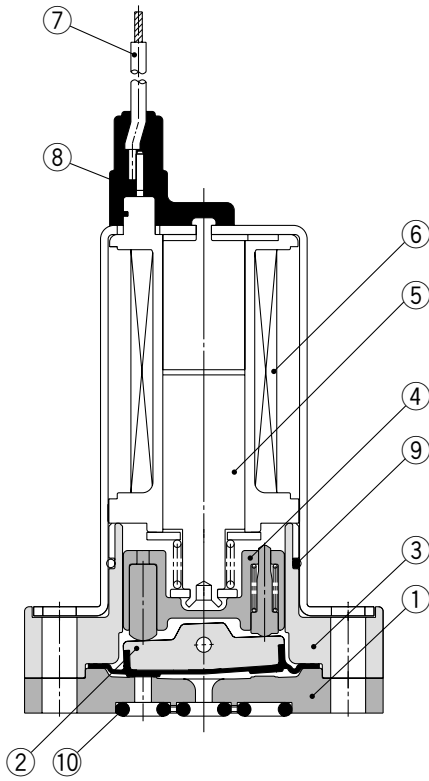

**LVM09R4**

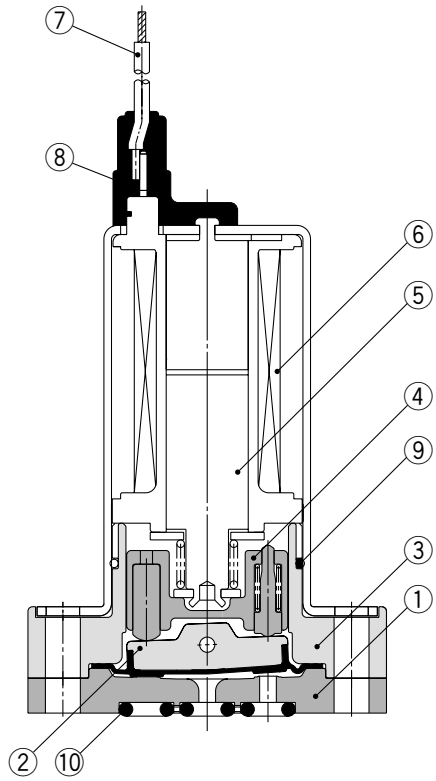

**LVM095R**

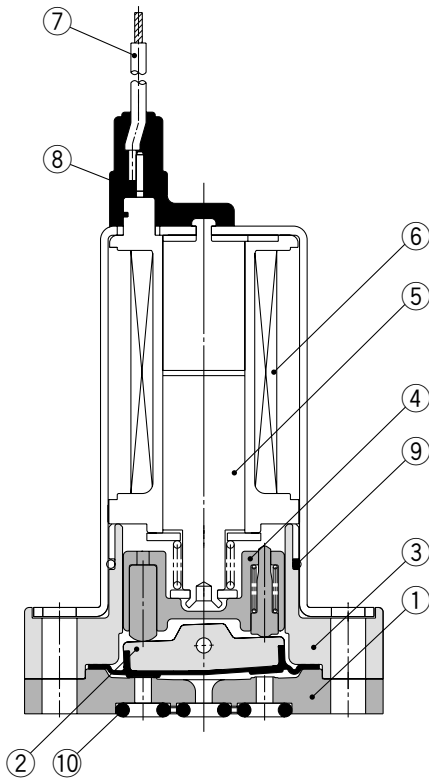

**Component Parts: LVM09R3, 09R4, 095R**

No.	Description	Material
1	Plate	PEEK
2	Diaphragm assembly	EPDM/FKM/Kalrez®
3	Body	PBT
4	Slide bushing assembly	PPS/Stainless steel
5	Armature assembly	—
6	Coil assembly	—
7	Lead wire	—
8	Mold	PET
9	O-ring	NBR
10	Interface gasket	EPDM/FKM/Kalrez®

# Series LVM09/090

## Dimensions: Base Mounted

LVM09R3  
LVM09R4  
LVM095R

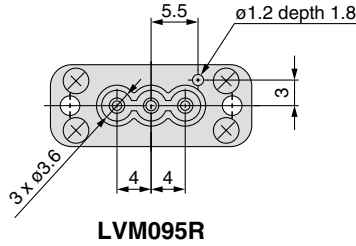

\* The broken lines indicate "with power-saving circuit".

With power-saving circuit (Y1 only)

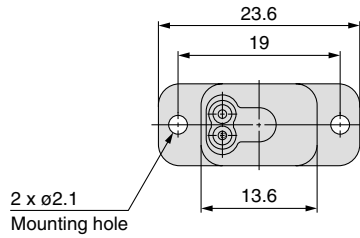
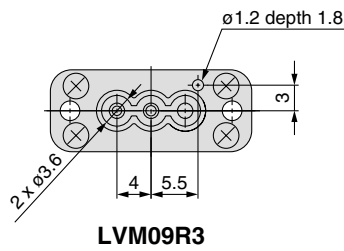
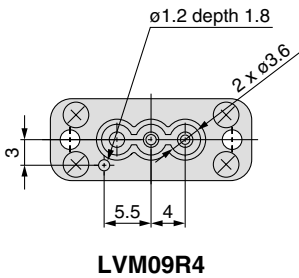
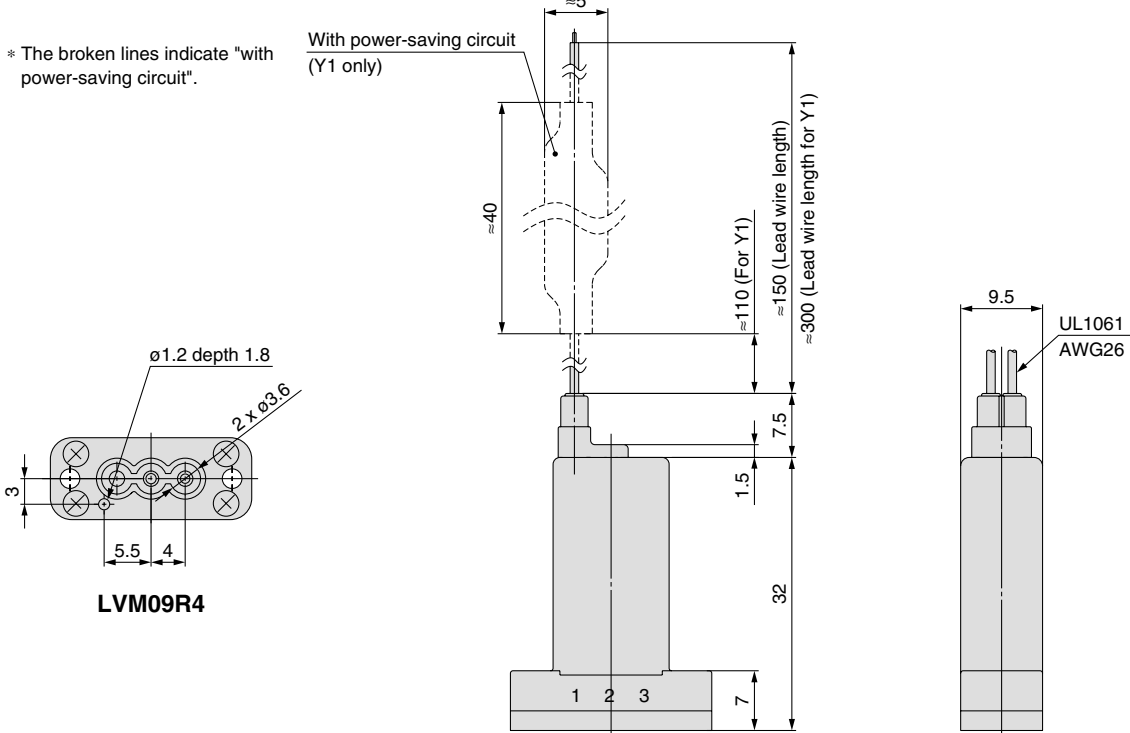

### Recommended interface dimensions

\* Surface roughness = Rz3.2 or less

\* Surface roughness = Rz3.2 or less

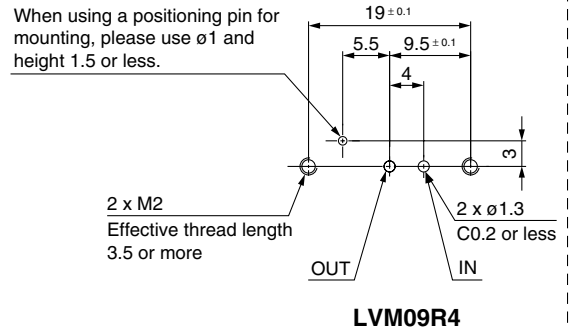
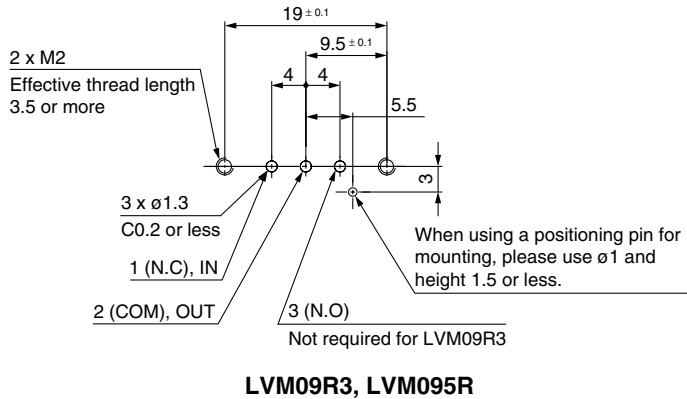



# Compact Direct Operated 2/3 Port Solenoid Valve for Chemicals

## Series *LVM10/100*

### How to Order

Symbol	Number of ports	Valve type	Connection
11		N.C. 	M5 thread
10R1	2	N.C. 	Tubing type
10R2		N.O. 	
102R	3	Universal 	

Symbol	Number of ports	Valve type
10R3		N.C. 
10R4	2	N.O. 
10R6		N.C. 
105R	3	Universal 

• **Wetted part material**

Symbol	Plate	Diaphragm
<b>A</b>	PEEK	EPDM
<b>B</b>	PEEK	FKM
<b>C</b>	PEEK	Kalrez®

• **Option**

-	None
<b>1</b>	Bracket
<b>2</b>	Manual override
<b>3</b>	Bracket, Manual override

\* Only Option 1 can be selected for LVM11

**Body Ported** LVM **11** **5** **A** — **Q**

**Base Mounted** LVM **10R3** **5** **A** **1** — **Q**

• **Function**

-	Standard
<b>Y</b>	With power-saving circuit

\* For LVM11, the type with power-saving circuit is standard.

• **Coil voltage**

Symbol	Voltage
<b>5</b>	24 VDC
<b>6</b>	12 VDC

• **Wetted part material**

Symbol	Plate	Diaphragm
<b>A</b>	PEEK	EPDM
<b>B</b>	PEEK	FKM
<b>C</b>	PEEK	Kalrez®
<b>E</b>	PFA	EPDM
<b>F</b>	PFA	FKM
<b>G</b>	PFA	Kalrez®

• **Lead wire length**

-	300 mm
<b>6</b>	600 mm
<b>10</b>	1000 mm

• **Option**

-	None
<b>1</b>	Bracket
<b>2</b>	Manual override
<b>3</b>	Bracket, Manual override

\* Without a sub-plate, a bracket cannot be attached.

• **Sub-plate material/Port size**

-	Without sub-plate	
<b>1*</b>	PVDF	M6
<b>1U*</b>	PVDF	1/4-28UNF
<b>2</b>	PFA	M6
<b>2U</b>	PFA	1/4-28UNF

\* Combinations with wetted part materials E, F, G are not available.

# Series LVM10/100

## Specifications



Body ported



Body ported  
(Tubing type)



Base mounted  
(Without sub-plate)



Base mounted  
(With sub-plate)

Model	Body ported	Body ported (Tubing type)			Base mounted			
	LVM11	LVM10R1	LVM10R2	LVM102R	LVM10R3	LVM10R4	LVM10R6	LVM105R
Valve construction	Diaphragm type direct operated poppet	Diaphragm type direct operated poppet (Rocker type)						
Valve type	N.C.	N.C.	N.O.	Universal	N.C.	N.O.	N.C.	Universal
Number of ports	2	2		3	2		3	
Fluid <sup>Note 1)</sup>	Air, Water, Pure water, Diluent, Cleaning solvent							
Operating pressure range	0 to 0.25 MPa	-75 kPa to 0.25 MPa						
Orifice diameter	1.5 mm	1.4 mm						
Response time	10 ms or less (at pneumatic pressure)							
Leakage	Zero leakage, either external or internal (at water pressure)							
Proof pressure <sup>Note 2)</sup>	0.38 MPa							
Ambient temperature	0 to 50°C							
Fluid temperature	0 to 50°C (with no condensation)							
Volume of valve chamber	11 μℓ	20 μℓ						
Mounting orientation	Free							
Enclosure	IP40 or equivalent							
Weight	30 g	34 g (without sub-plate), 42 g (with sub-plate)						
Rated voltage	12, 24 VDC							
Allowable voltage fluctuation <sup>Note 5)</sup>	±10% of rated voltage							
Type of coil insulation	Class B							
Power consumption (When rated voltage is at 24 V)	Standard	—		1.5 W (0.06 A)				
	With power-saving circuit	In-rush	2.5 W (0.1 A)					
		Hold-ing	1 W					
Coil switching noise <sup>Note 5)</sup>	50 dB							

Note 1) Select an appropriate material for the wetted part when fluids such as a cleaning solvents are used. Also, be sure to confirm the fluid compatibility in advance.

Note 2) Indicates the pressure which does not generate breakage, cracks or external leakage after a one-minute airtight test.

Note 3) Indicates the volume of clearance inside the valve chamber after the volume of the diaphragm is subtracted.

Note 4) Since the body (orifice shape) is designed to eliminate residual liquid, mounting in a vertical direction with the coil at the top is recommended. When residual liquid is not considered, any mounting orientation is available.

Note 5) When the response speed is regarded as important, prevent negative fluctuation of the voltage by adequate regulation.

Note 6) The value is based on SMC's measurement conditions. The noise level will vary with conditions.

Note 7) Refer to 10 in "Design and Selection" on back page 2 if the valve is to be energised continuously for extended periods of time.

## Flow Characteristics

Valve construction	Water		Air	
	Av	Cv	C	b
Direct operated poppet	0.96 x 10 <sup>-6</sup>	0.04	0.13	0.22
Rocker type	0.72 x 10 <sup>-6</sup>	0.03	0.1	0.2

\* The values for Av and Cv are based on JIS B 2005:1995, C and b are based on JIB B 8390:2000.

**Construction: Body Ported**

**LVM11**

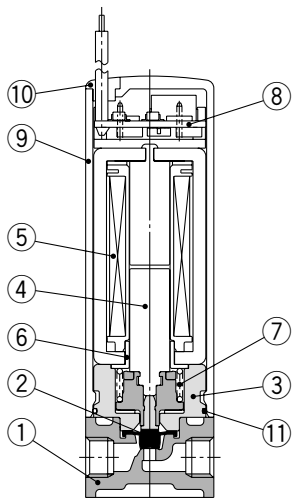

**Component Parts: LVM11**

No.	Description	Material
1	<b>Body</b>	PEEK
2	<b>Diaphragm assembly</b>	EPDM/FKM/Kalrez®
3	<b>Spacer</b>	PBT
4	<b>Armature assembly</b>	Stainless steel/POM
5	<b>Coil assembly</b>	—
6	<b>Sleeve</b>	SUY (iron)
7	<b>Return spring</b>	Stainless steel
8	<b>Board assembly</b>	—
9	<b>Casing</b>	PBT
10	<b>Plug</b>	NBR
11	<b>O-ring</b>	NBR

**LVM10R1**

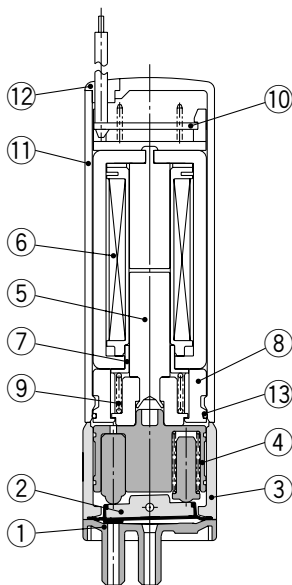

**LVM10R2**

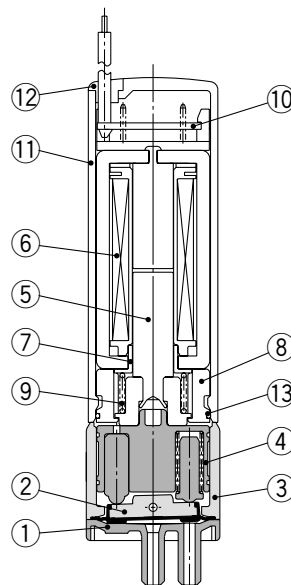

**LVM102R**

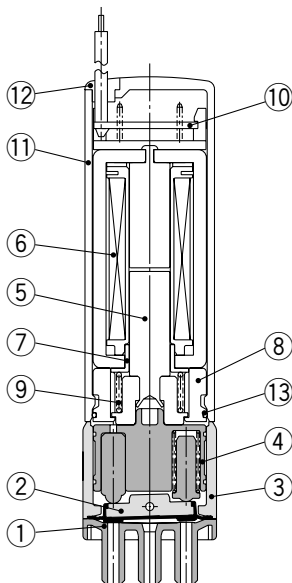

**Component Parts: LVM10R1, 10R2, 102R**

No.	Description	Material
1	<b>Plate</b>	PEEK
2	<b>Diaphragm assembly</b>	EPDM/FKM/Kalrez®
3	<b>Body</b>	PBT
4	<b>Slide bushing assembly</b>	POM/Stainless steel
5	<b>Armature assembly</b>	Stainless steel/PBT
6	<b>Coil assembly</b>	—
7	<b>Sleeve</b>	SUY (iron)
8	<b>Spacer</b>	PBT
9	<b>Return spring</b>	Stainless steel
10	<b>Board assembly</b>	—
11	<b>Casing</b>	PBT
12	<b>Plug</b>	NBR
13	<b>O-ring</b>	NBR

# Series LVM10/100

## Construction: Base Mounted

LVM10R3

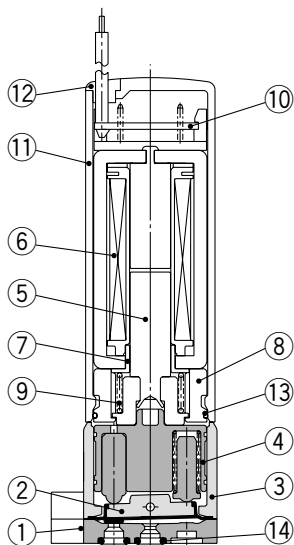

LVM10R4

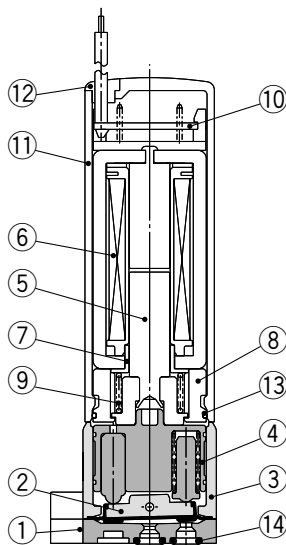

LVM10R6

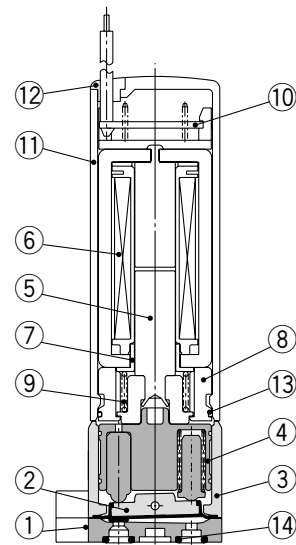

LVM105R

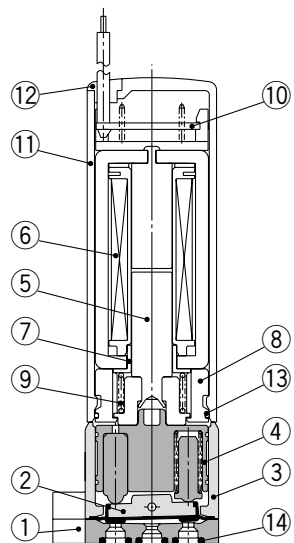

Component Parts: LVM10R3, 10R4, 10R6, 105R

No.	Description	Material
1	Plate	PEEK/PFA
2	Diaphragm assembly	EPDM/FKM/Kalrez®
3	Body	PBT
4	Slide bushing assembly	POM/Stainless steel
5	Armature assembly	Stainless steel/PBT
6	Coil assembly	—
7	Sleeve	SUY (iron)
8	Spacer	PBT
9	Return spring	Stainless steel
10	Board assembly	—
11	Casing	PBT
12	Plug	NBR
13	O-ring	NBR
14	O-ring	EPDM/FKM/Kalrez®

**Compact Direct Operated  
2/3 Port Solenoid Valve for Chemicals Series LVM10/100**

**Dimensions: Body Ported**

**LVM11-□□-□ (N.C.)**

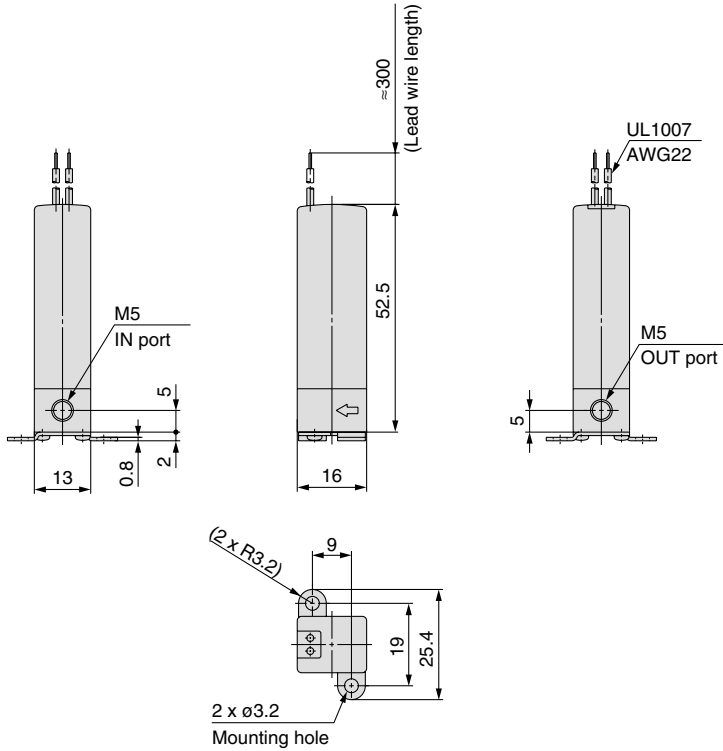

**LVM10R1-□□-□ (N.C.)**

**LVM10R2-□□-□ (N.O.)**

**LVM102R-□□-□ (Universal)**

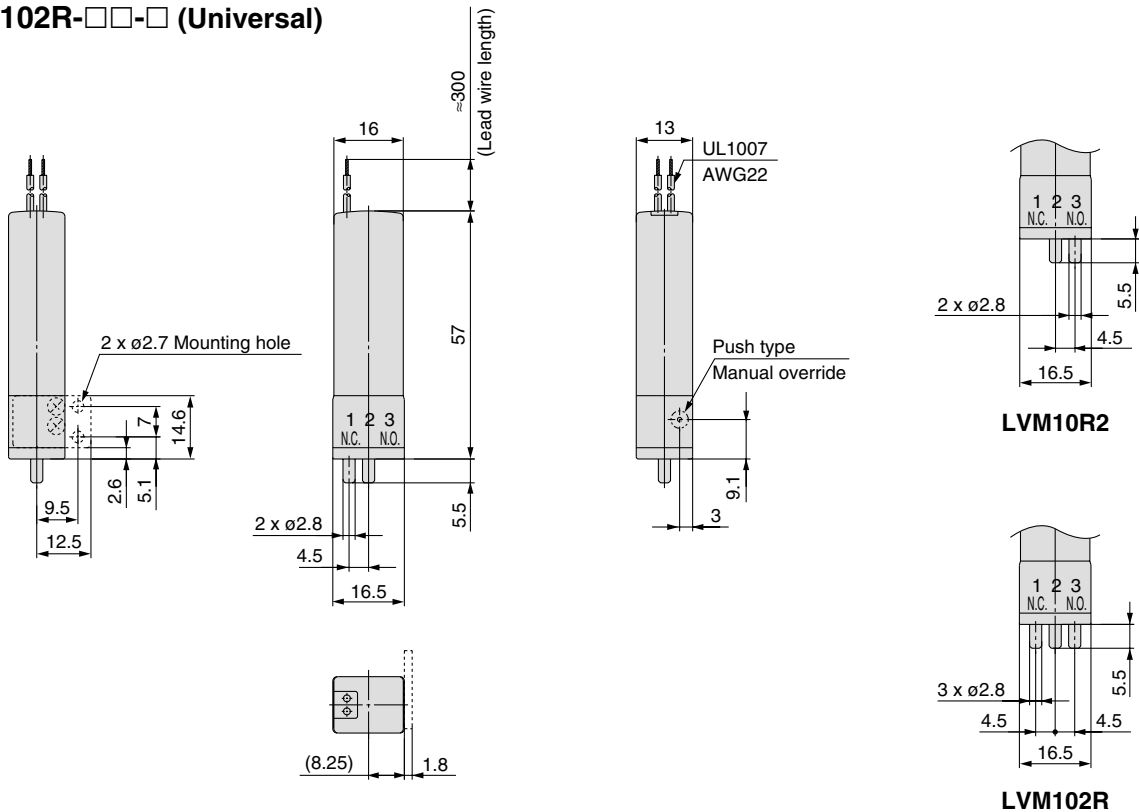

\* The broken lines indicate "with bracket".

# Series LVM10/100

## Dimensions: Base Mounted

LVM10R3-□□-□ (N.C.)

LVM10R4-□□-□ (N.O.)

LVM10R6-□□-□ (N.C.)

LVM105R-□□-□ (Universal)

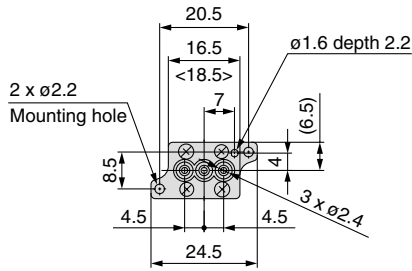

LVM105R

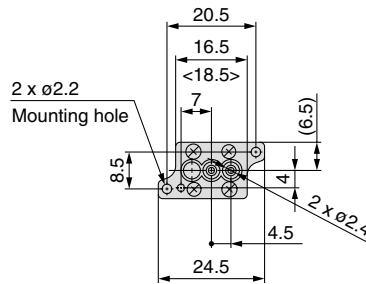

LVM10R4

\* Figures in brackets < > indicate the values for the PFA plate material (wetted part material "E, F, G"). In case of the PFA plate material (wetted part material "E, F, G"), there is no  $\phi 1.6$  positioning hole.

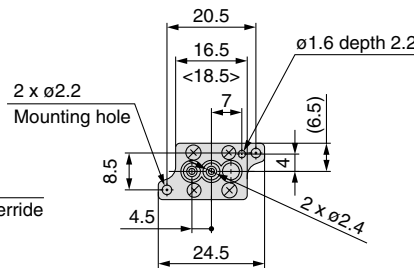
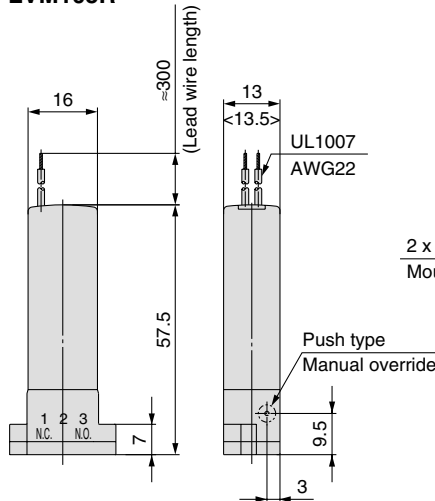

LVM10R3

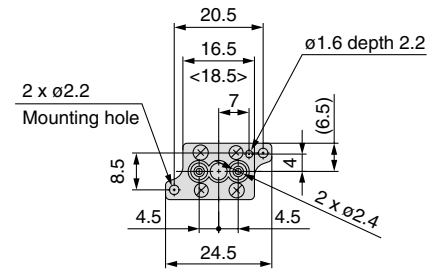

LVM10R6

### Recommended interface dimensions

\* Surface roughness = Rz3.2 or less

\* Surface roughness = Rz3.2 or less

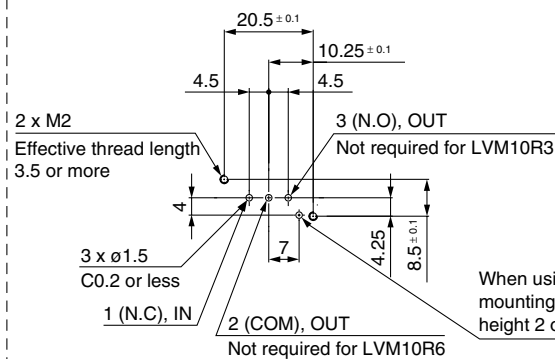

LVM10R3, LVM10R6, LVM105R

When using a positioning pin for mounting, please use  $\phi 1.5$  and height 2 or less.

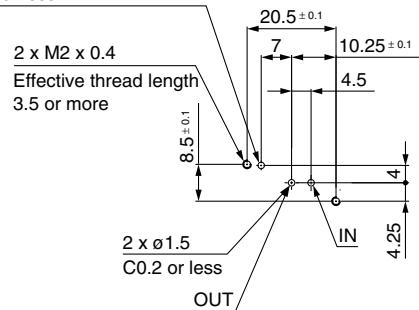

LVM10R4

# Compact Direct Operated 2/3 Port Solenoid Valve for Chemicals *Series LVM10/100*

## Dimensions: Base Mounted

LVM10R3-□□□-□ (N.C.)

LVM10R4-□□□-□ (N.O.)

LVM10R6-□□□-□ (N.C.)

LVM105R-□□□-□ (Universal)

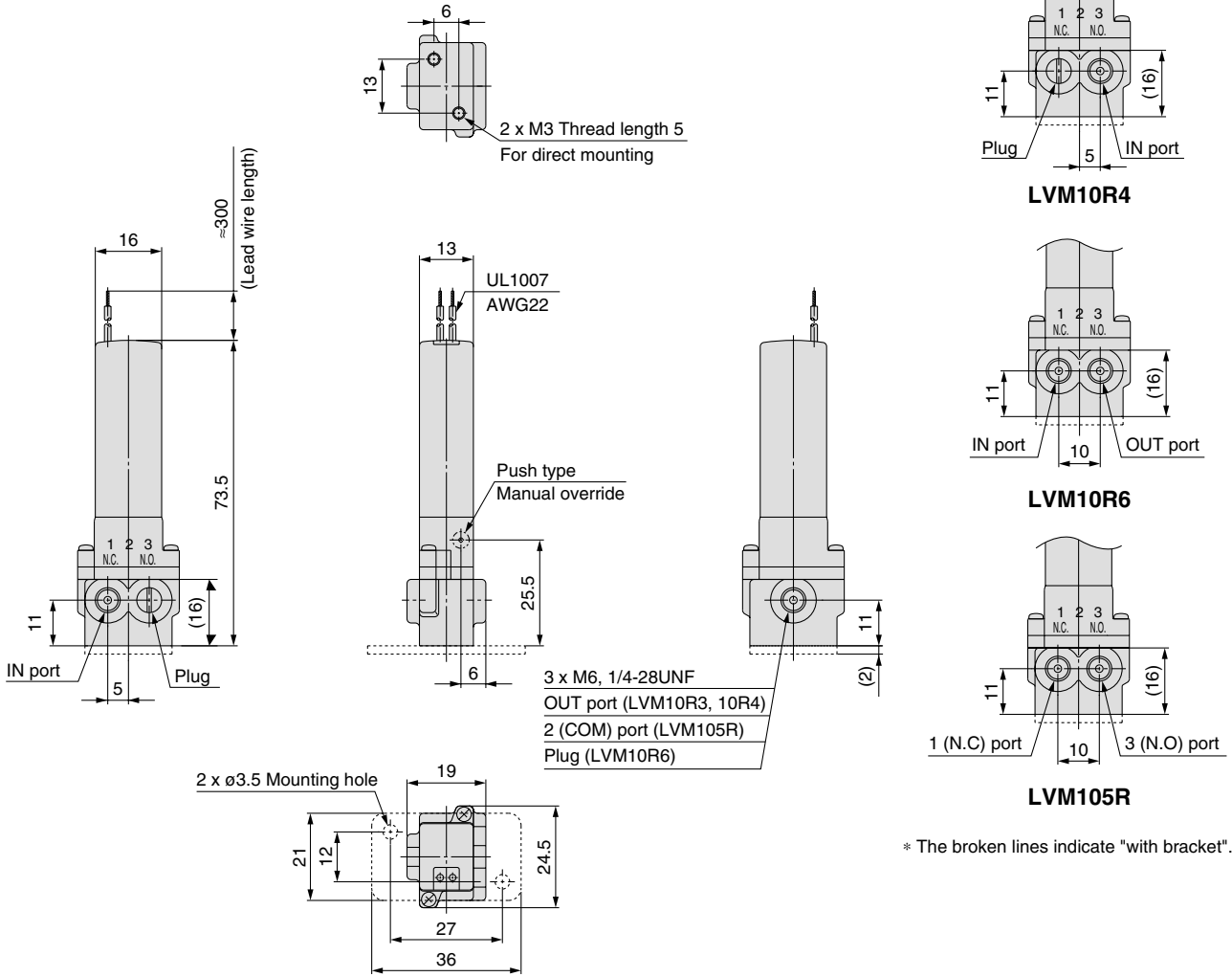

# Compact Direct Operated 2/3 Port Solenoid Valve for Chemicals Series *LVM15/150*

## How to Order



Base Mounted

LVM 15R3 Y - 5 A - [ ] - Q

Symbol

Symbol	Number of ports	Valve type	
15R3	2	N.C.	
15R4		N.O.	
155R	3	Universal	

### Lead wire length

-	300 mm
6	600 mm
10	1000 mm

### Wetted part material

Symbol	Plate	Diaphragm
A	PEEK	EPDM
B	PEEK	FKM
C	PEEK	Kalrez®

### Coil voltage

Symbol	Voltage
5	24 VDC
6	12 VDC

### Function

Symbol	Specifications
Y	Standard (With power-saving circuit)
HY	High-pressure type (With power-saving circuit)

## Specifications

Model	Base mounted		
	LVM15R3	LVM15R4	LVM155R
Valve construction	Diaphragm type direct operated poppet (Rocker type)		
Valve type	N.C.	N.O.	Universal
Number of ports	2		3
Fluid <sup>Note 1)</sup>	Air, Water, Pure water, Diluent, Cleaning solvent		
Operating pressure range	-75 kPa to 0.25 MPa [0 to 0.6 MPa]		
Orifice diameter	1.6 mm [1 mm]		
Response time	15 ms or less (at pneumatic pressure)		
Leakage	Zero leakage, either external or internal (at water pressure)		
Proof pressure <sup>Note 2)</sup>	0.38 MPa [0.9 MPa]		
Ambient temperature	0 to 50°C		
Fluid temperature	0 to 50°C (with no condensation)		
Volume of valve chamber <sup>Note 3)</sup>	50 μℓ		
Mounting orientation <sup>Note 4)</sup>	Free		
Enclosure	IP40 or equivalent		
Weight	45 g		
Rated voltage	12, 24 VDC		
Allowable voltage fluctuation <sup>Note 5)</sup>	±10% of rated voltage		
Type of coil insulation	Class B		
Power consumption (When rated voltage is at 24 V)	Inrush	5.5 W (0.23 A)	
	Holding	1 W	
Coil switching noise <sup>Note 6)</sup>	60 dB		

[ ] indicates high-pressure type.

Note 1) Select an appropriate material for the wetted part when fluids such as a cleaning solvents are used. Also, be sure to confirm the fluid compatibility in advance.

Note 2) Indicates the pressure which does not generate breakage, cracks or external leakage after a one-minute airtight test.

Note 3) Indicates the volume of clearance inside the valve chamber after the volume of the diaphragm is subtracted.

Note 4) Since the body (orifice shape) is designed to eliminate residual liquid, mounting in a vertical direction with the coil at the top is recommended. When residual liquid is not considered, any mounting orientation is available.

Note 5) When the response speed is regarded as important, prevent negative fluctuation of the voltage by adequate regulation.

Note 6) The value is based on SMC's measurement conditions. The noise level will vary with conditions.

Note 7) Refer to 10 in "Design and Selection" on back page 2 if the valve is to be energised continuously for extended periods of time.

## Flow Characteristics

Function	Water		Air	
	Av	Cv	C	b
Standard	0.96 x 10 <sup>-6</sup> [0.36 x 10 <sup>-6</sup> ]	0.04 [0.015]	0.13 [0.05]	0.22 [0.2]

\* The values for Av and Cv are based on JIS B 2005:1995, C and b are based on JIB B 8390:2000.



**Construction: Base Mounted**

**LVM15R3**

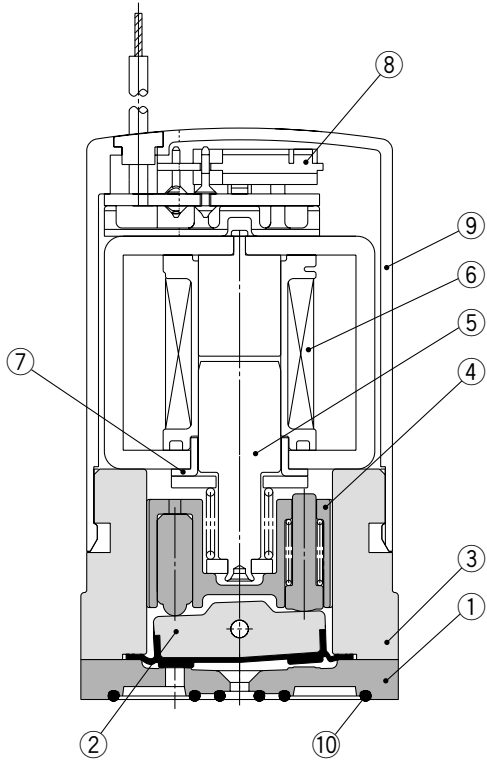

**LVM15R4**

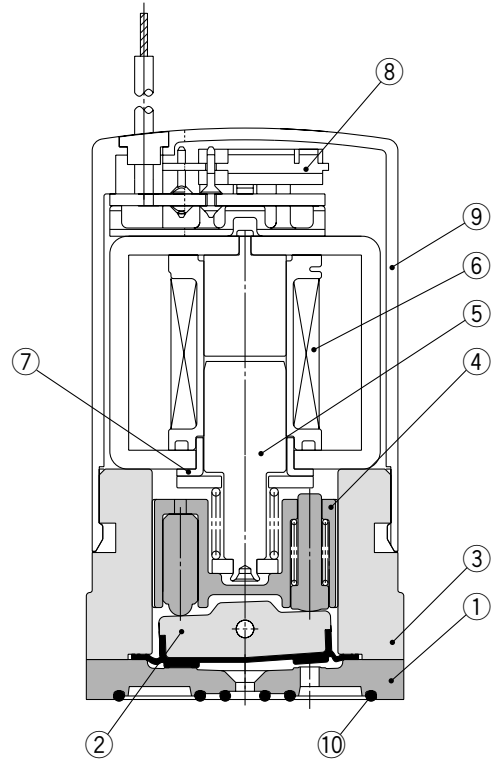

**LVM155R**

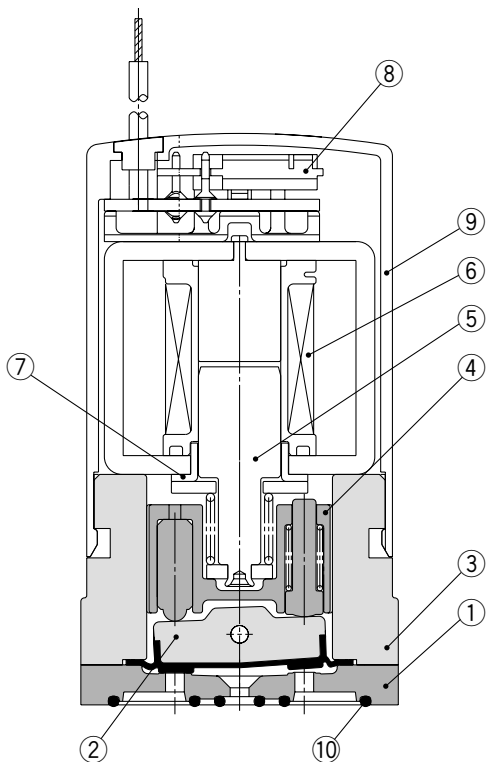

**Component Parts: LVM15R3, 15R4, 155R**

No.	Description	Material
1	Plate	PEEK
2	Diaphragm assembly	EPDM/FKM/Kalrez®
3	Body	PBT
4	Slide bushing assembly	PPS/Stainless steel
5	Armature assembly	—
6	Coil assembly	—
7	Sleeve	SUY (iron)
8	Board assembly	—
9	Casing	PBT
10	Interface gasket	EPDM/FKM/Kalrez®

# Series LVM15/150

## Dimensions: Base Mounted

LVM15R3  
LVM15R4  
LVM155R

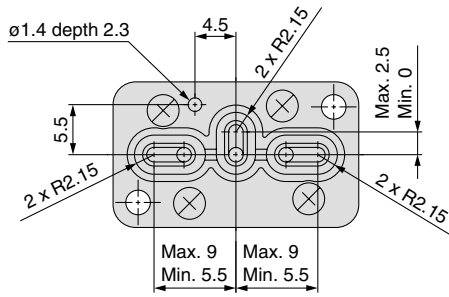

LVM155R

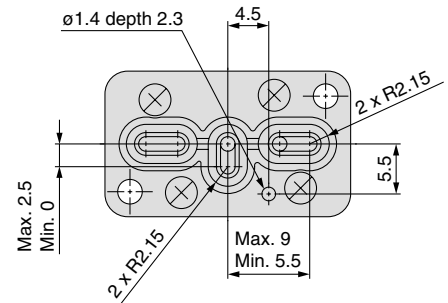
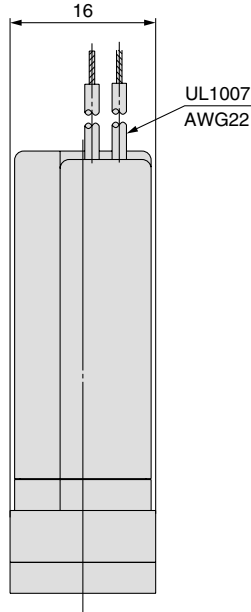
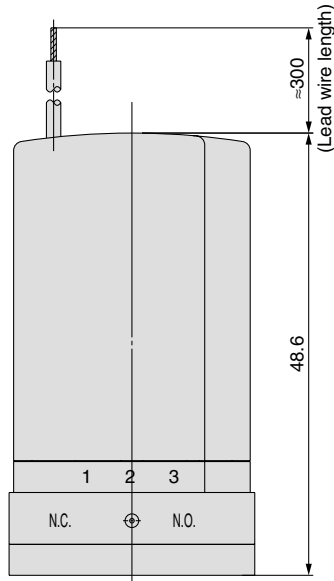

LVM15R4

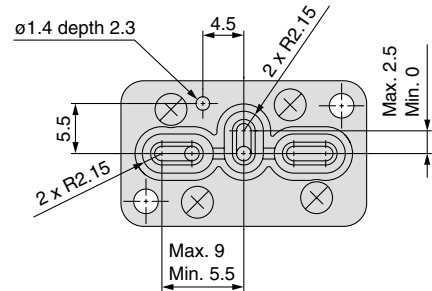
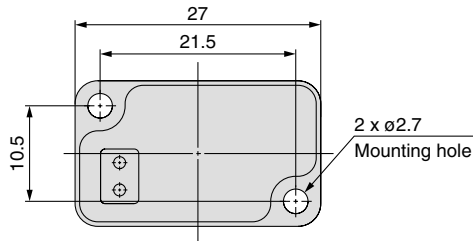

LVM15R3

### Recommended interface dimensions

\* Surface roughness = Rz3.2 or less

\* Surface roughness = Rz3.2 or less

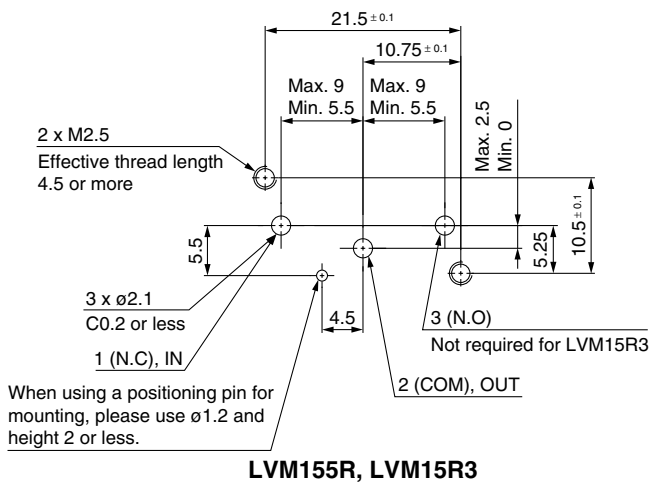

LVM155R, LVM15R3

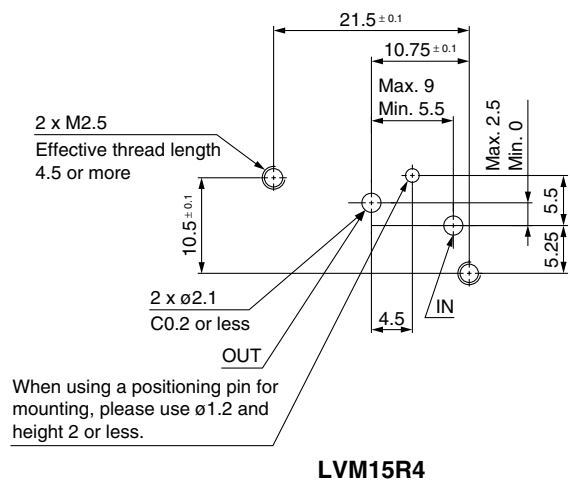

LVM15R4

# Compact Direct Operated 2/3 Port Solenoid Valve for Chemicals Series *LVM20/200*

## How to Order

**Base Mounted** LVM **20R3** - **5** **A** - **Q**

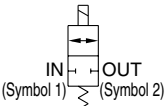
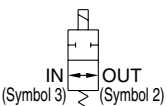
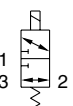
Symbol	Number of ports	Valve type
20R3	2	N.C. 
20R4		N.O. 
205R	3	Universal 

### Lead wire length

-	300 mm
6	600 mm
10	1000 mm

### Wetted part material

Symbol	Plate	Diaphragm
A	PEEK	EPDM
B	PEEK	FKM
C	PEEK	Kalrez®

### Coil voltage

Symbol	Voltage
5	24 VDC
6	12 VDC

### Function

-	Standard
Y	With power-saving circuit



## Specifications

Model	Base mounted		
	LVM20R3	LVM20R4	LVM205R
Valve construction	Diaphragm type direct operated poppet (Rocker type)		
Valve type	N.C.	N.O.	Universal
Number of ports	2		3
Fluid <sup>Note 1)</sup>	Air, Water, Pure water, Diluent, Cleaning solvent		
Operating pressure range	-75 kPa to 0.3 MPa		
Orifice diameter	2 mm		
Response time	20 ms or less (at pneumatic pressure)		
Leakage	Zero leakage, either external or internal (at water pressure)		
Proof pressure <sup>Note 2)</sup>	0.45 MPa		
Ambient temperature	0 to 50°C		
Fluid temperature	0 to 50°C (with no condensation)		
Volume of valve chamber <sup>Note 3)</sup>	84 μℓ		
Mounting orientation <sup>Note 4)</sup>	Free		
Enclosure	IP40 or equivalent		
Weight	80 g		
Rated voltage	12, 24 VDC		
Allowable voltage fluctuation <sup>Note 5)</sup>	±10% of rated voltage		
Type of coil insulation	Class B		
Power consumption (When rated voltage is at 24 V)	Standard		2.5 W (0.1 A)
	With power-saving circuit	Inrush	4 W (0.17 A)
		Holding	0.6 W
Coil switching noise <sup>Note 6)</sup>	60 dB		

Note 1) Select an appropriate material for the wetted part when fluids such as a cleaning solvents are used. Also, be sure to confirm the fluid compatibility in advance.

Note 2) Indicates the pressure which does not generate breakage, cracks or external leakage after a one-minute airtight test.

Note 3) Indicates the volume of clearance inside the valve chamber after the volume of the diaphragm is subtracted.

Note 4) Since the body (orifice shape) is designed to eliminate residual liquid, mounting in a vertical direction with the coil at the top is recommended. When residual liquid is not considered, any mounting orientation is available.

Note 5) When the response speed is regarded as important, prevent negative fluctuation of the voltage by adequate regulation.

Note 6) The value is based on SMC's measurement conditions. The noise level will vary with conditions.

Note 7) Refer to 10 in "Design and Selection" on back page 2, if the valve is to be energised continuously for extended periods of time.

## Flow Characteristics

Water		Air	
Av	Cv	C	b
1.56 x 10 <sup>-6</sup>	0.065	0.23	0.27

\* The values for Av and Cv are based on JIS B 2005:1995, C and b are based on JIB B 8390:2000.

# Series LVM20/200

## Construction: Base Mounted

LVM20R3

LVM20R4

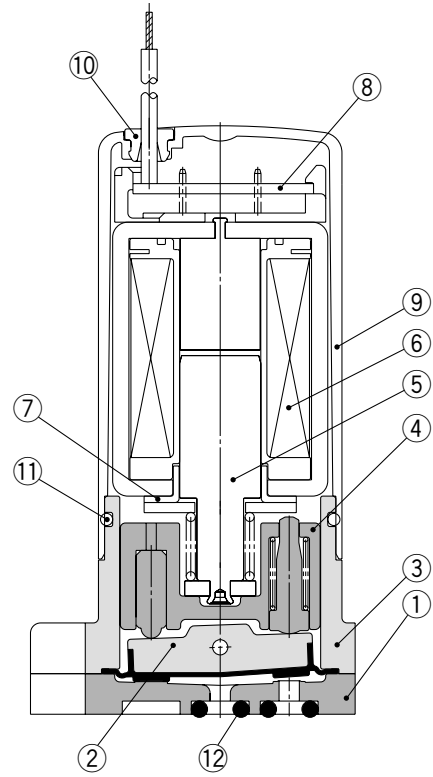
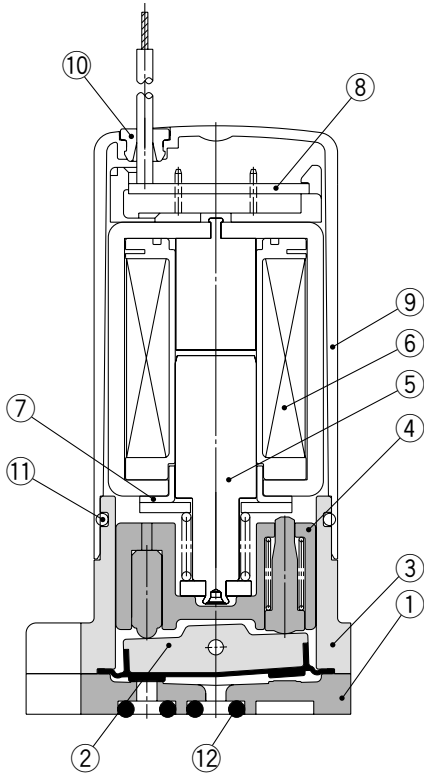

LVM205R

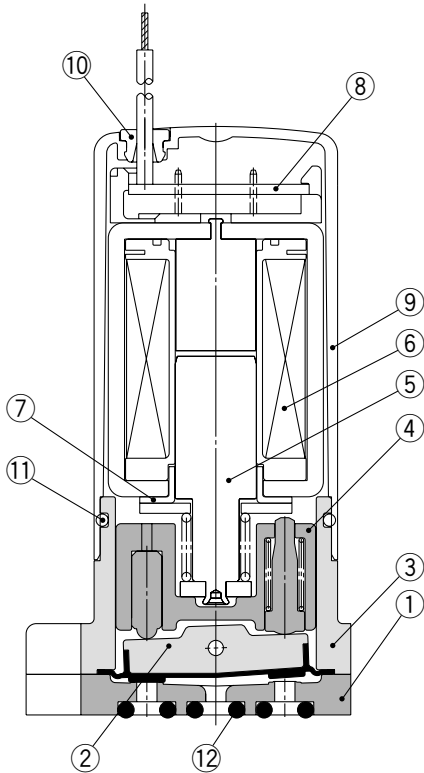

Component Parts: LVM20R3, 20R4, 205R

No.	Description	Material
1	Plate	PEEK
2	Diaphragm assembly	EPDM/FKM/Kalrez®
3	Body	PBT
4	Slide bushing assembly	PPS/Stainless steel
5	Armature assembly	—
6	Coil assembly	—
7	Sleeve	SUY (iron)
8	Board assembly	—
9	Casing	PBT
10	Plug	NBR
11	O-ring	NBR
12	O-ring	EPDM/FKM/Kalrez®

**Dimensions: Base Mounted**

**LVM20R3  
LVM20R4  
LVM205R**

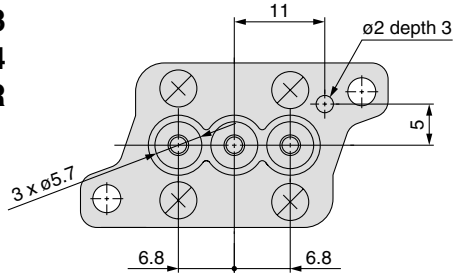

**LVM205R**

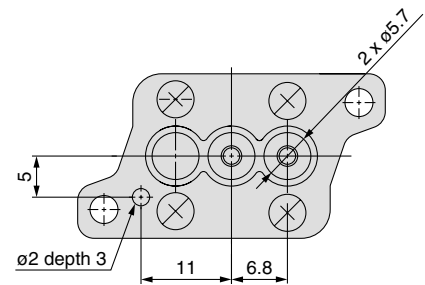
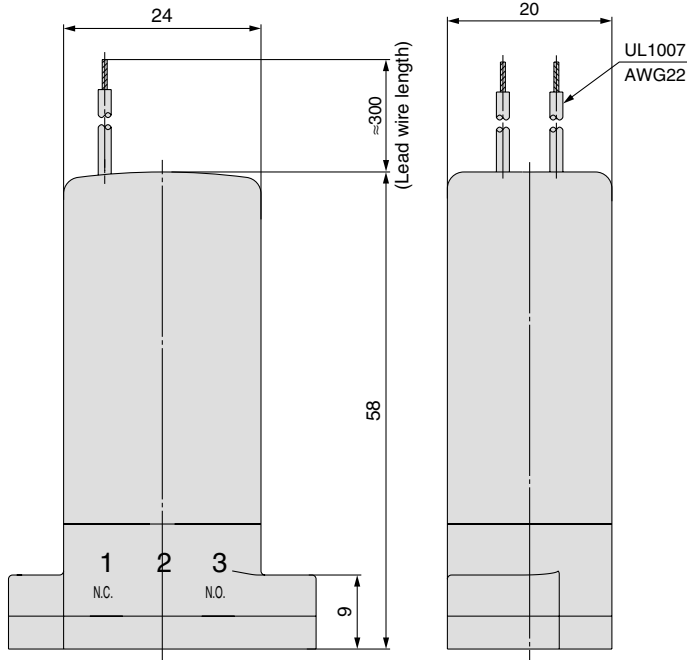

**LVM20R4**

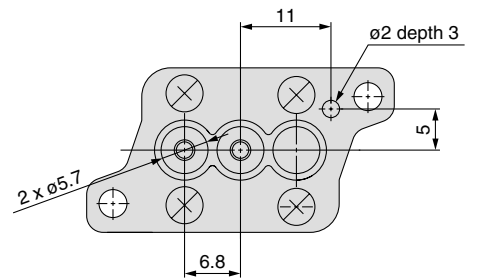
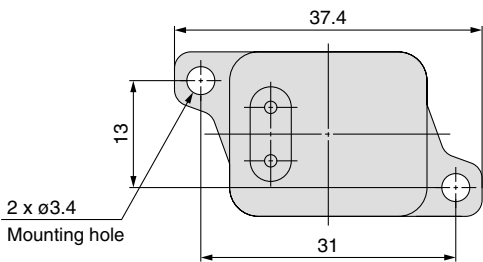

**LVM20R3**

**Recommended interface dimensions**

\* Surface roughness = Rz3.2 or less

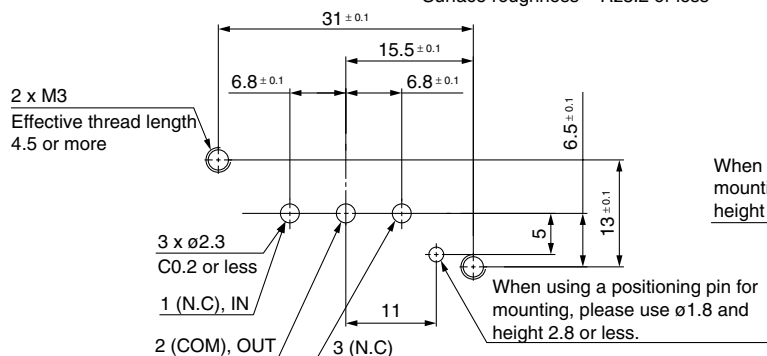

Not required for LVM20R3  
**LVM20R3, LVM205R**

\* Surface roughness = Rz3.2 or less

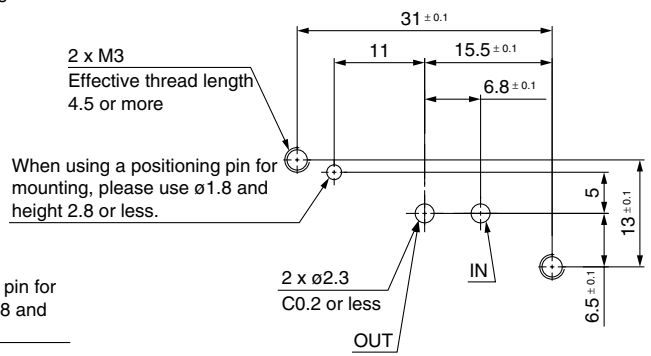

**LVM20R4**





**Series LVM**

# Safety Instructions

The following safety instructions are intended to prevent a hazardous situation and/or equipment damage. These instructions indicate the level of potential hazard by all safety practices, including labels of "**Caution**", "**Warning**" or "**Danger**". To ensure safety, please observe ISO 4414 <sup>Note 1)</sup>, JIS B 8370 <sup>Note 2)</sup>.

 **Caution:** Operator error could result in injury or equipment damage.

 **Warning:** Operator error could result in serious injury or loss of life.

 **Danger :** In extreme conditions, there is a possible result of serious injury or loss of life.

Note 1) ISO 4414: Pneumatic fluid power – General rules relating to systems

Note 2) JIS B 8370: General Rules for Pneumatic Equipment

## Warning

### **1. The compatibility of the equipment is the responsibility of the person who designs the system or decides its specifications.**

Since the products specified here are used in various operating conditions, their compatibility with a specific system must be based on specifications, post analysis and/or tests to meet a specific requirement. The expected performance and safety assurance will be the responsibility of the person who has determined the compatibility of the system. This person should continuously review the suitability of all items specified, referring to the latest catalogue information and taking into consideration the possibility of equipment failure when configuring a system. Be particularly careful in determining the compatibility with the fluid to be used.

### **2. Only trained personnel should operate machinery and equipment.**

Fluids can be dangerous if handled incorrectly. Assembly, handling or maintenance of the system should be performed by trained and experienced operators.

### **3. Do not service machinery/equipment or attempt to remove components until the safety is confirmed.**

1. Inspection and maintenance of machinery/equipment should only be performed once measures to prevent falling or runaway of the driven object have been confirmed. Measures to prevent danger from a fluid should also be confirmed.

2. When equipment is to be removed, confirm the safety processes mentioned above, release the fluid pressure and be certain there is no danger from fluid leakage or fluid remaining in the system.

3. Carefully restart the machinery, confirming that safety measures are being implemented.

### **4. If the equipment will be used in the following conditions or environments, please contact SMC first and be sure to take all necessary safety precautions.**

1. Conditions and environments beyond the given specifications, or if the product is used outdoors.

2. With fluids whose application causes concern due to the type of fluid or additives, etc.

3. An application which has the possibility of having a negative effect on people and/or property, and therefore requires special safety analysis.



# Series LVM Specific Product Precautions 1

Be sure to read this before handling. Contact SMC when it is used in conditions other than the specifications.

## Design and Selection

### Warning

**1. Do not use this product in applications which may adversely affect human life (e.g. medical equipment connected to the human body for drip infusion).**

**2. Confirm the specifications.**

Give careful consideration to the operating conditions such as the application, fluid and environment, and use within the operating ranges specified in this catalogue.

**3. Fluid**

Be sure to confirm the compatibility between the component material and the fluid.

**4. Maintenance space**

The installation should allow sufficient space for maintenance activities.

**5. Fluid pressure range**

Fluid pressure should be within the allowable pressure range.

**6. Ambient environment**

Use within the allowable ambient temperature range. Be sure that the fluid used does not touch the external surface of the product.

**7. Countermeasures against static electricity**

Take measures to prevent static electricity since some fluids can cause static electricity.

**8. Pressure (including vacuum) holding**

It is not usable for an application such as holding the pressure (including vacuum) inside of a pressure vessel because air leakage is entailed in a valve.

**9. Cannot be used as an emergency shutoff valve**

The valves presented in this catalogue are not designed for safety applications such as an emergency shutoff valve. If the valves are used in this type of system, other reliable safety assurance measures should also be adopted.

**10. Extended periods of continuous energisation**

If solenoid valves are to be continuously energised for extended periods of time, use valves with power-saving circuits to minimise the amount of heat released by the coil.

#### Power-saving circuit waveform (example)

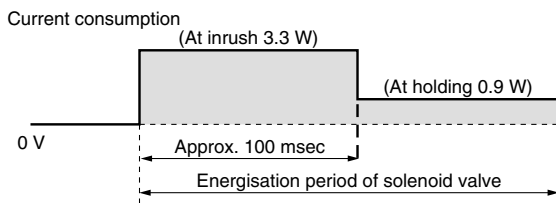

- \* Power consumption for the waveform shown above is that of LVM09/090.
- \* For LVM15/150, the type with power-saving circuit is standard.
- \* For LVM10/100, the inrush is 50 msec.

When a solenoid valve without a power-saving circuit is continuously energised for long periods of time, a temperature increase from the coil heat release can result in worsened performance and shortened service life of the solenoid valve, as well as adverse effects on peripheral equipment in the vicinity. For this reason, when valves are to be continuously energised for extended periods, use a fan or take other measures to disperse heat and keep the valve surface temperatures at 70°C or less.

The table below shows reference values for continuously energised valves (single unit) when surface temperature is 70°C or less.

Series	LVM09/090	LVM10/100	LVM20/200
Period of continuous energisation	5 min. or less	30 min. or less	30 min. or less
Duty ratio	50% or less		
Ambient temperature	25°C or less		
Power-saving circuit	None		

\* Duty ratio: ON time/(ON time + OFF time)

\* For LVM15/150, the type with power-saving circuit is standard.

Please use a fan or take other measures to disperse heat and keep temperatures within the specified range when mounting the solenoid valves inside control panels, etc. Be especially careful when using three or more adjacent valves with manifolds and keeping them continuously energised for extended periods, as this may result in dramatic increases in temperature.

**11. Please use valve pitches equal to or above those shown in the table below when using multiple valves together.**

Series	LVM09/090	LVM10/100	LVM15/150	LVM20/200
Valve pitch	10.5	14	17	21

## Mounting

### Warning

**1. If air leakage increases or the equipment does not operate properly, stop operation.**

After mounting is completed, confirm that it has been done correctly by performing a suitable function test.

**2. Since the body (orifice shape) is designed to eliminate residual liquid, mounting in a vertical direction with the coil on top is recommended.**

When residual liquid is not considered, any mounting position is possible.



# Series LVM Specific Product Precautions 2

Be sure to read this before handling. Contact SMC when it is used in conditions other than the specifications.

## Piping

### ⚠ Caution

#### 1. Preparation before piping

Before piping is connected, it should be thoroughly blown out with air (flushing) or washed to remove chips, cutting oil and other debris from inside the pipe.

#### 2. When tubing is directly connected to the solenoid valve, insert the tubing straight into the nipple for a complete fit.

The reference inner diameter of the tubing is  $\phi 2.5$  or less. Exercise care in selecting the tubing so that the outer diameter of the tubing after being connected does not exceed  $\phi 4.5$ .

The holding force varies by the tubing material. Be sure to confirm the holding force of each material before operation.

After connecting the tubing, care should be taken not to put excessive force (tensile force, compression, bending, etc.) on the tubing. Applying an external force greater than 20 N to the nipple may cause leakage.

Models: LVM10R1, 10R2, 102R

#### 3. Always tighten threads with the proper tightening torque.

Screw the fitting into the solenoid valve and tighten by referring to the tightening torque below.

Models: LVM11, 10R3, 10R4, 10R6, 105R

#### Tightening Torque for Piping

Model	Thread size	Proper tightening torque N·m	
Base mounted LVM09R3, 09R4, 095R	M2	0.1 to 0.14	
Body ported LVM11	M5	1.5 to 2	
Base mounted LVM10R3, 10R4, 10R6, 105R	Without sub-plate	M2 (Note)	0.15 to 0.2
	With sub-plate	M6 or 1/4-28UNF	1.5 to 2
Base mounted LVM15R3, 15R4, 155R	M2.5	0.25 to 0.35	
Base mounted LVM20R3, 20R4, 205R	M3	0.4 to 0.6	

Note) At base mounted

\* Reference

M5, M6, 1/4-28UNF thread type fitting: After tightening by hand, tighten approximately 1/6 turn with a tightening tool.

## Wiring

### ⚠ Caution

#### 1. Use electrical circuits which do not generate chattering in their contacts.

#### 2. Use voltage which is within $\pm 10\%$ of the rated voltage.

However, when the response time is important, control the voltage to avoid variation on the minus side.

#### 3. Apply the correct voltage.

Applying incorrect voltage may cause a malfunction or a burned coil.

#### 4. Connect the wires so that an external force greater than 10 N is not applied to the lead wire.

Otherwise the coil will burn.

#### 5. Units with power-saving circuits use polarised electrical connections.

Red (+), Black (-)

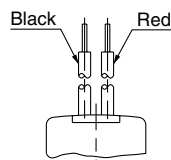

## Fluid Properties

### ⚠ Warning

#### Liquid (chemicals)

Components crystallise or clot depending on their nature. Leakage will occur when a crystallised or clotted component is caught between the sealing parts.

Take measures to clean such component if necessary.

#### Water

Install a filter strainer of about 100 mesh on the inlet side of the piping.

#### Air

Compressed air filtered with a filter with filtration rating of 5  $\mu\text{m}$  or less, which is mounted on the inlet side of the piping, should be used.

## Operating Environment

### ⚠ Warning

#### 1. Do not use in explosive atmospheres.

#### 2. Do not use in locations subject to excessive vibration or impact.

Impact resistance of this solenoid valve is 150 m/s<sup>2</sup>. Vibration resistance of this solenoid valve is 30 m/s<sup>2</sup>.

#### 3. Do not use in locations where radiated heat will be received from nearby heat sources.

## Maintenance

### ⚠ Warning

#### 1. Removing the product

Shut off the fluid supply and release the fluid pressure in the system. Shut off the power supply. Remove the product.

#### 2. Before operating, remove residual chemicals and completely replace it with deionised water, air, etc.

#### 3. Do not disassemble the product.

Products which have been disassembled cannot be guaranteed. If disassembly is necessary, contact SMC.

## Record of changes

- |                  |  |
|------------------|--|
| <b>B edition</b> | * Addition of the LVM09/090, LVM15/150, LVM20/200 series.<br>* Change of model numbers for the LVM10/100 series.<br>* Number of pages from 12 to 28. |
|------------------|--|

LU









**EUROPEAN SUBSIDIARIES:****Austria**

SMC Pneumatik GmbH (Austria).  
Girakstrasse 8, A-2100 Korneuburg  
Phone: +43 2262-62280, Fax: +43 2262-62285  
E-mail: office@smc.at  
http://www.smc.at

**France**

SMC Pneumatique, S.A.  
1, Boulevard de Strasbourg, Parc Gustave Eiffel  
Bussy Saint Georges F-77607 Marne La Vallée Cedex 3  
Phone: +33 (0)1-6476 1000, Fax: +33 (0)1-6476 1010  
E-mail: contact@smc-france.fr  
http://www.smc-france.fr

**Netherlands**

SMC Pneumatics BV  
De Ruyterkade 120, NL-1011 AB Amsterdam  
Phone: +31 (0)20-5318888, Fax: +31 (0)20-5318880  
E-mail: info@smcpneumatics.nl  
http://www.smcneumatics.nl

**Spain**

SMC España, S.A.  
Zuazobidea 14, 01015 Vitoria  
Phone: +34 945-184 100, Fax: +34 945-184 124  
E-mail: post@smc-smces.es  
http://www.smces.es

**Belgium**

SMC Pneumatics N.V./S.A.  
Nijverheidsstraat 20, B-2160 Wommelgem  
Phone: +32 (0)3-355-1464, Fax: +32 (0)3-355-1466  
E-mail: post@smcpneumatics.be  
http://www.smcneumatics.be

**Germany**

SMC Pneumatik GmbH  
Boschring 13-15, D-63329 Egelsbach  
Phone: +49 (0)6103-4020, Fax: +49 (0)6103-402139  
E-mail: info@smc-pneumatik.de  
http://www.smc-pneumatik.de

**Norway**

SMC Pneumatics Norway A/S  
Vollsveien 13 C, Granfos Næringspark N-1366 Lysaker  
Tel: +47 67 12 90 20, Fax: +47 67 12 90 21  
E-mail: post@smc-norge.no  
http://www.smc-norge.no

**Sweden**

SMC Pneumatics Sweden AB  
Ekhagsvägen 29-31, S-141 71 Huddinge  
Phone: +46 (0)8-603 12 00, Fax: +46 (0)8-603 12 90  
E-mail: post@smcpneumatics.se  
http://www.smc.nu

**Bulgaria**

SMC Industrial Automation Bulgaria EOOD  
16 kllment Ohridski Blvd., fl.13 BG-1756 Sofia  
Phone: +359 2 9744492, Fax: +359 2 9744519  
E-mail: office@smc.bg  
http://www.smc.bg

**Greece**

SMC Hellas EPE  
Anageniseous 7-9 - P.C. 14342, N. Philadelphia, Athens  
Phone: +30-210-2717265, Fax: +30-210-2717766  
E-mail: sales@smchellas.gr  
http://www.smchellas.gr

**Poland**

SMC Industrial Automation Polska Sp.z.o.o.  
ul. Poloneza 89, PL-02-826 Warszawa,  
Phone: +48 22 211 9600, Fax: +48 22 211 9617  
E-mail: office@smc.pl  
http://www.smc.pl

**Switzerland**

SMC Pneumatik AG  
Dorfstrasse 7, CH-8484 Weisslingen  
Phone: +41 (0)52-396-3131, Fax: +41 (0)52-396-3191  
E-mail: info@smc.ch  
http://www.smc.ch

**Croatia**

SMC Industrijska automatika d.o.o.  
Crnomerec 12, 10000 ZAGREB  
Phone: +385 1 377 66 74, Fax: +385 1 377 66 74  
E-mail: office@smc.hr  
http://www.smc.hr

**Hungary**

SMC Hungary Ipari Automatizálási Kft.  
Budafoki út 107-113, H-1117 Budapest  
Phone: +36 1 371 1343, Fax: +36 1 371 1344  
E-mail: office@smc.hu  
http://www.smc.hu

**Portugal**

SMC Sucursal Portugal, S.A.  
Rua de Engº Ferreira Dias 452, 4100-246 Porto  
Phone: +351 22-610-89-22, Fax: +351 22-610-89-36  
E-mail: postpt@smc-smces.es  
http://www.smces.es

**Turkey**

Entek Pnömatik San. ve Tic. A\*.  
Perpa Ticaret Merkezi B Blok Kat:11 No: 1625, TR-34386, Okmeydanı, İstanbul  
Phone: +90 (0)212-444-0762, Fax: +90 (0)212-221-1519  
E-mail: smc@entek.com.tr  
http://www.entek.com.tr

**Czech Republic**

SMC Industrial Automation CZ s.r.o.  
Hudcova 78a, CZ-61200 Brno  
Phone: +420 5 414 24611, Fax: +420 5 412 18034  
E-mail: office@smc.cz  
http://www.smc.cz

**Ireland**

SMC Pneumatics (Ireland) Ltd.  
2002 Citywest Business Campus, Naas Road, Saggart, Co. Dublin  
Phone: +353 (0)1-403 9000, Fax: +353 (0)1-464-0500  
E-mail: sales@smcpneumatics.ie  
http://www.smcneumatics.ie

**Romania**

SMC Romania srl  
Str Frunzei 29, Sector 2, Bucharest  
Phone: +40 213205111, Fax: +40 213261489  
E-mail: smcromania@smcromania.ro  
http://www.smcromania.ro

**UK**

SMC Pneumatics (UK) Ltd  
Vincent Avenue, Crownhill, Milton Keynes, MK8 0AN  
Phone: +44 (0)800 1382930 Fax: +44 (0)1908-555064  
E-mail: sales@smcpneumatics.co.uk  
http://www.smcneumatics.co.uk

**Denmark**

SMC Pneumatik A/S  
Knudsminde 4B, DK-8300 Odder  
Phone: +45 70252900, Fax: +45 70252901  
E-mail: smc@smc-pneumatik.dk  
http://www.smc.dk

**Italy**

SMC Italia S.p.A  
Via Garibaldi 62, I-20061 Carugate, (Milano)  
Phone: +39 (0)2-92711, Fax: +39 (0)2-9271365  
E-mail: mailbox@smcitalia.it  
http://www.smcitalia.it

**Russia**

SMC Pneumatik LLC.  
4B Sverdlovskaja nab, St. Petersburg 195009  
Phone: +7 812 718 5445, Fax: +7 812 718 5449  
E-mail: info@smc-pneumatik.ru  
http://www.smc-pneumatik.ru

**Estonia**

SMC Pneumatics Estonia OÜ  
Laki 12, 106 21 Tallinn  
Phone: +372 6510370, Fax: +372 65110371  
E-mail: smc@smcpneumatics.ee  
http://www.smcneumatics.ee

**Latvia**

SMC Pneumatics Latvia SIA  
Smerla 1-705, Riga LV-1006  
Phone: +371 781-77-00, Fax: +371 781-77-01  
E-mail: info@smclv.lv  
http://www.smclv.lv

**Slovakia**

SMC Priemyselna Automatizacia, s.r.o.  
Námestie Matina Benku 10, SK-81107 Bratislava  
Phone: +421 2 444 56725, Fax: +421 2 444 56028  
E-mail: office@smc.sk  
http://www.smc.sk

**Finland**

SMC Pneumatics Finland Oy  
PL72, Tiistinniintie 4, SF-02231 ESPOO  
Phone: +358 207 513513, Fax: +358 207 513595  
E-mail: smcfi@smc.fi  
http://www.smc.fi

**Lithuania**

SMC Pneumatics Lietuva, UAB  
Oslo g.1, LT-04123 Vilnius  
Phone: +370 5 264 81 26, Fax: +370 5 264 81 26

**Slovenia**

SMC industrijska Avtomatika d.o.o.  
Mirnska cesta 7, SLO-8210 Trebnje  
Phone: +386 7 3885412 Fax: +386 7 3885435  
E-mail: office@smc.si  
http://www.smc.si

**OTHER SUBSIDIARIES WORLDWIDE:**

ARGENTINA, AUSTRALIA, BOLIVIA, BRASIL, CANADA, CHILE,  
CHINA, HONG KONG, INDIA, INDONESIA, MALAYSIA, MEXICO,  
NEW ZEALAND, PHILIPPINES, SINGAPORE, SOUTH KOREA,  
TAIWAN, THAILAND, USA, VENEZUELA

<http://www.smc.eu>  
<http://www.smcworld.com>