

Escapements
Series MIW/MIS
ø8, ø12, ø20, ø25, ø32

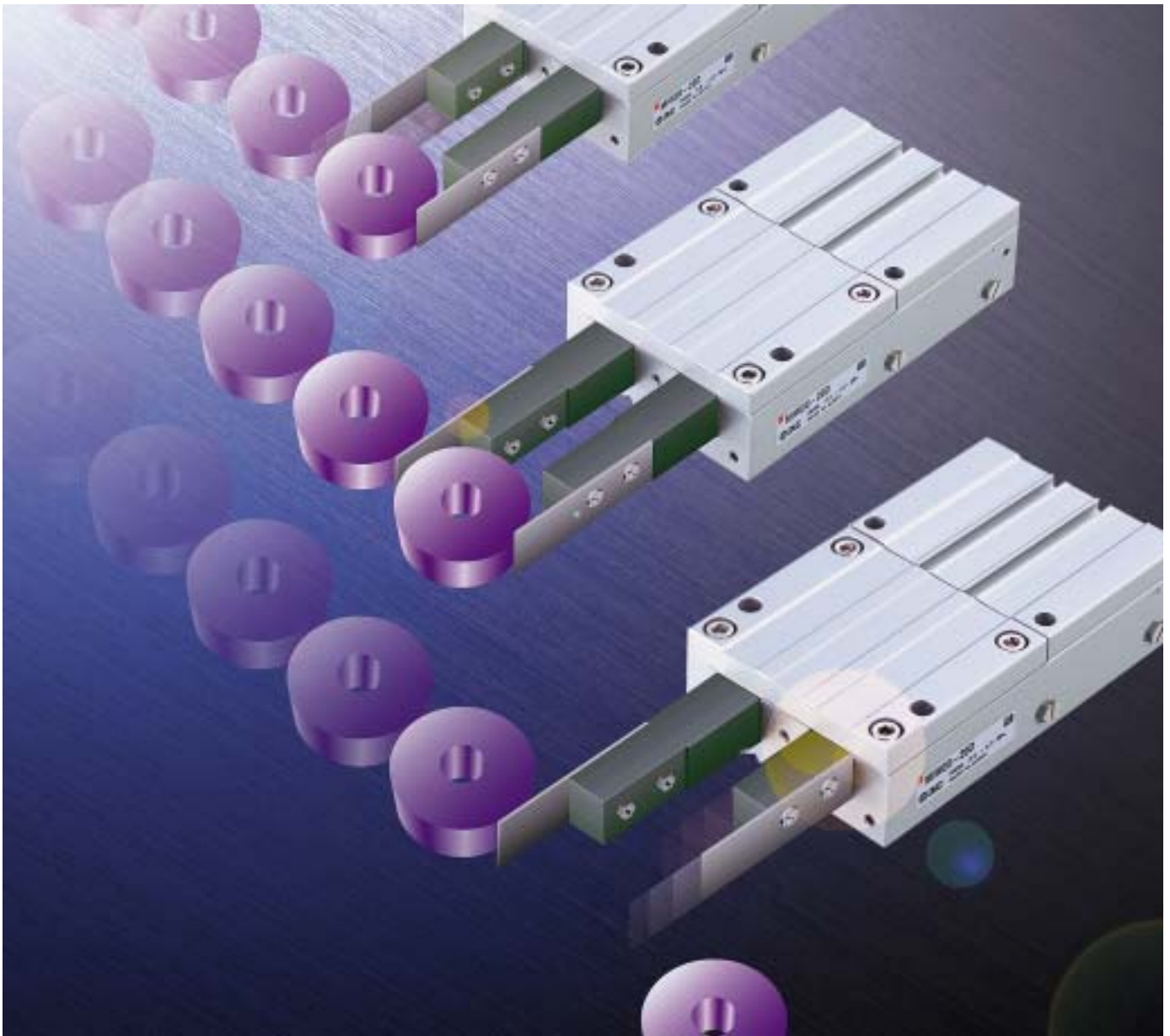

Ideal for separating and feeding individual parts from vibratory feeders, magazines, and hoppers.

ø8, ø25, ø32
additionally released

Ideal for separating and from vibratory feeders,

Scraper (optional)

Optional scraper prevents entry of dust to protect internal components.

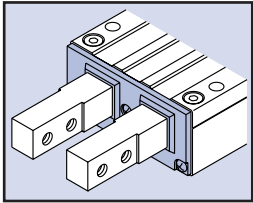

Air passage

Auto switch capable

Floating mechanism

Improves life of the escapement by preventing eccentric loads causing damage to the piston and the seals. As this mechanism separates the fingers from the piston, it is possible to replace the fingers with ease when required.

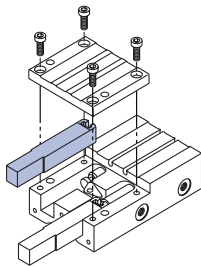

Interlocking

Provides reliable performance of the escapement by interlocking the two piston rods with a cam mechanism and control of air passage to the pistons.

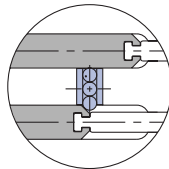

For $\varnothing 25$ and $\varnothing 32$, lock mechanism for heavier load is available.

Stroke adjuster (optional)

Optional stroke adjuster for precise adjustment of the retracted position of each piston rod.

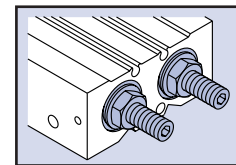

Three variations of fingers

Flexibility in mounting the finger options.

Finger options

Basic type

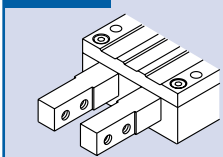

Tapped on upper and lower faces

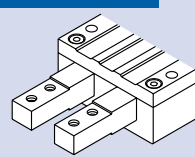

Tapped on all faces

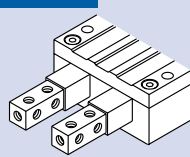

Mounting is possible from 2 directions.

Using through holes from top face

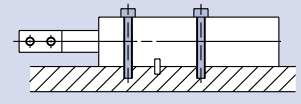

Using tapped holes in the body from bottom face

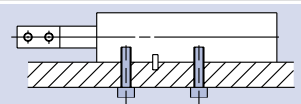

* Positioning pin holes allow for easy mounting.

$\varnothing 8$, $\varnothing 25$, $\varnothing 32$ additionally released



Piping from three directions are possible (Two directions for MIS)

Port position can be adjusted along with setting conditions by changing plug position.

MIW

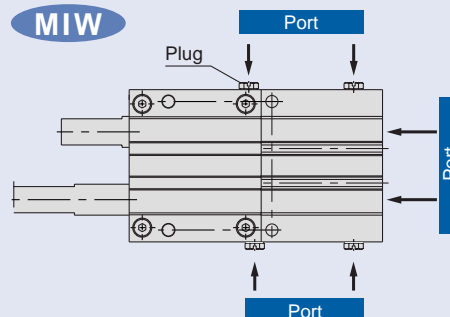

MIS

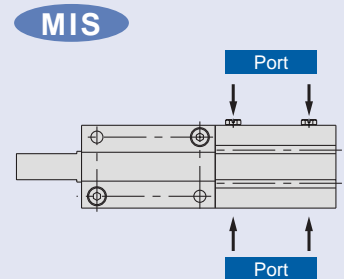

feeding individual parts magazines, and hoppers.

Application examples

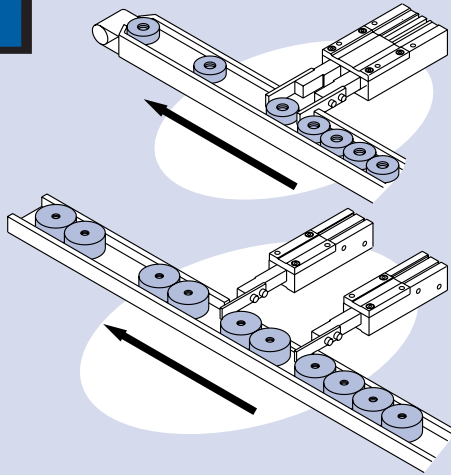

MIW Double finger type

Single valve operation easily separates and feed each work piece.

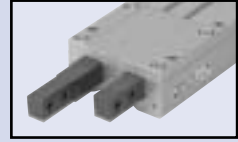

MIS Single finger type

Operating speed and mounting position can be set according to the size of work piece and its operating condition.

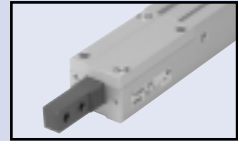

Working principle

The cam locks Finger B.

When Finger A is extended to reach the stroke end, air is supplied to retract Finger B.

Extension of Finger A rotates the cam to unlock Finger B and lock finger A to allow retraction of Finger B.

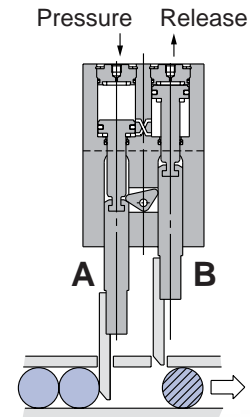
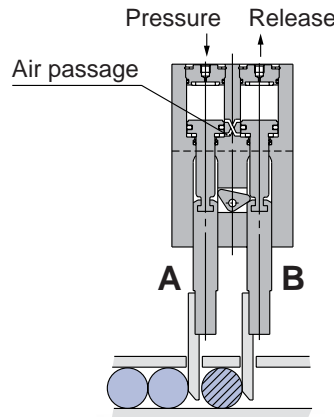
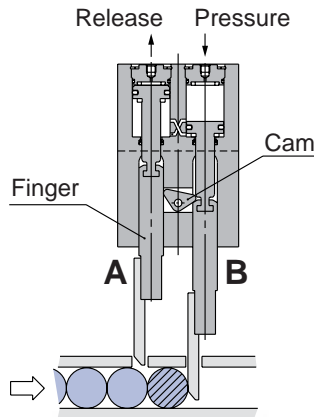

Insertion

Separation

Release

Series variations

Series	Bore size (mm)	Stroke (mm)								Finger option	Stroke adjuster	Scrapper
		8	10	12	20	25	30	32	50			
MIW	8	●								●	●	●
	12			●						●	●	●
	20				●					●	●	●
	25					●				●	●	●
	32							●		●	●	●
MIS	8		●		●					●	●	●
	12		●		●		●			●	●	●
	20		●		●		●			●	●	●
	25				●		●			●	●	●
	32						●		●	●	●	●

Series MIW/MIS Model Selection 1

Model Selection

Selection procedure

Procedure 1 Condition confirmation

Procedure 2 Confirmation of impact by work piece

Procedure 3 Confirmation of allowable lateral load

Procedure 1 Confirmation of conditions

- The work piece moves horizontally on the conveyor.

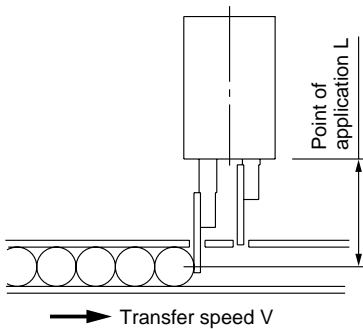

Operation conditions
 Operating pressure P (MPa)
 Work piece weight m (Kg)
 Work piece quantity x (Qty.)
 Point of application L (mm)
 Work piece transfer speed
 V (m/min)
 Coefficient of friction
 between the work piece
 and conveyor μ

- When the work piece drops vertically from a shooter, etc.

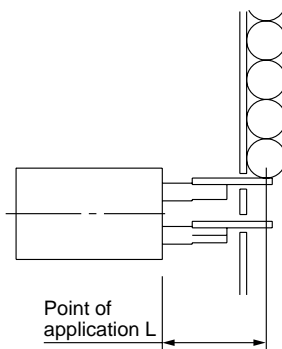

Operation conditions
 Operating pressure P (MPa)
 Work piece weight m (Kg)
 Work piece quantity x (Qty.)
 Point of application L (mm)
 Distance of work piece drop
 H (m/min)
 Gravitational acceleration g (m/s²)

Procedure 2 Confirmation of impact

From the graph of operating range, obtain the point of intersection of the total weight of the work piece xm (kg) indicated by the axis of ordinates and the transfer speed V (m/min) indicated by the axis of abscissas. Select a model so that the intersection will fall below the point of application L indicated by a line.

1. Calculation of work piece collision speed
 The collision speed V is calculated from the distance of work piece fall H .

$$\text{Work piece collision speed } V = \sqrt{2gH/1000} \times 60 \text{ (m/min)}$$

2. From the graph of operating range, obtain the intersection of the total weight of the work piece xm (kg) indicated by the axis of ordinates and the collision speed V (m/min) obtained by calculation. Select a model so that the intersection will fall below the point of application L indicated by a line.

Procedure 3 Confirmation of allowable lateral load

1. Calculation of applied lateral load F
 The lateral load F equals the coefficient between the work piece and the conveyor. Thus, from the total amount of the work piece and coefficient of friction,

$$F = \mu \cdot x \cdot m \cdot g \text{ (N)}$$

1. Calculation of applied lateral load
 The lateral load F equals the total load of the work piece.
 Thus,
$$F = x \cdot m \cdot g \text{ (N)}$$

2. From the graph of allowable lateral load, obtain the allowable lateral load F_{max} from the intersection of the operating pressure and the point of application L indicated by the axis of abscissas. Select a model so that the value will be larger than the lateral load F applied in real operation.
 Lateral load: $F \leq$ Allowable lateral load: F_{max}

Model Selection

Operating range

Procedure 1 Confirmation of conditions

- The work piece moves horizontally on the conveyor.

Operating conditions

Operating pressure	P = 0.4 MPa
Work piece weight	m = 0.1 kg
Work piece quantity	x = 10
Point of application	L = 50 mm
Work piece transfer speed	V = 12 m/min
Coefficient of friction between the work piece and conveyor $\mu = 0.2$	

- When the work piece drops vertically from a shooter, etc.

Operating conditions

Operating pressure	P = 0.4 MPa
Work piece weight	m = 0.05 kg
Work piece quantity	x = 5
Point of application	L = 60 mm
Distance of work piece drop	H = 15 mm
Gravitation acceleration	g = 9.8 m/s

Procedure 2 Confirmation of impact

- Obtain the total amount of the work piece.
Total weight $m = 10 \times 0.1$ (kg) = 1 (kg)
- Obtain the intersection of the transfer speed V and the total weight of work piece m . Confirm that the value is within the operating range of the point of application $L = 50$ mm $\varnothing 12$

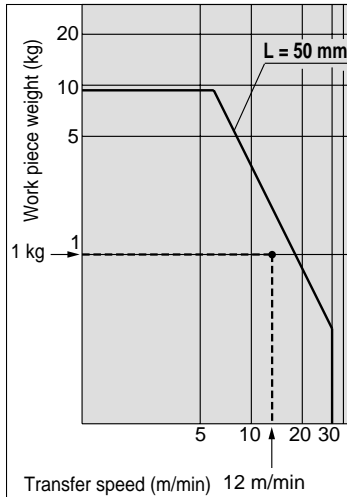

- Obtain the total amount of the work piece.
Total weight $m = 5 \times 0.05$ (kg) = 0.25 (kg)
- Obtain the collision speed of the work piece V .

$$V = \sqrt{2gH/1000 \times 60}$$

$$= \sqrt{2 \times 9.8 \times 15/1000 \times 60} \quad \varnothing 20$$

$$= 32.5 \text{ (m/min)}$$

- Obtain the intersection of the collision speed V and the total weight of the work piece m . Confirm that the value is within the operating range of the point of application $L = 60$ mm.

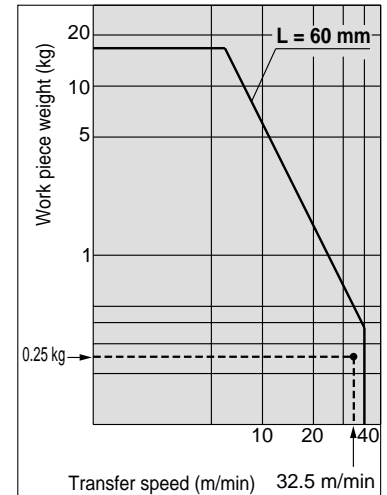

Procedure 3 Confirmation of allowable lateral load

- Calculation of applied lateral load F

$$F = \mu \cdot N \cdot m \cdot g \text{ (N)}$$

$$= 0.2 \times 10 \times 0.1 \times 9.8$$

$$= 2.1 \text{ (N)}$$

- Confirmation of allowable lateral load
From the graph, the allowable lateral load at $L = 50$ mm and $P = 0.4$ MPa is 18 N. Because 2.1 N < 18 N, it is applicable.

**MIW12
MIS12**

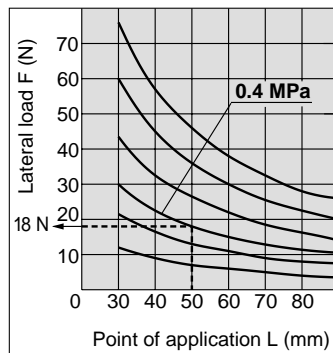

- Calculation of applied lateral load
The lateral load F equals the total load of the work piece. Thus,
 $F = 5 \times 0.05 \times 9.8$
 $= 2.5$ (N)

- Confirmation of allowable lateral load
In the same way, the lateral load at $L = 50$ mm and $P = 0.4$ MPa is 48 N from the graph. Because 2.5 N < 48 N, it is applicable.

Therefore select MIW (MIS) 12.

Therefore select MIW (MIS) 20.

Series MIW/MIS

Model Selection 2

Model Selection

Operating range

The graph at right shows conditions of the work piece to be stopped; that is, the weight, transfer speed and the operating range of the point of application L.

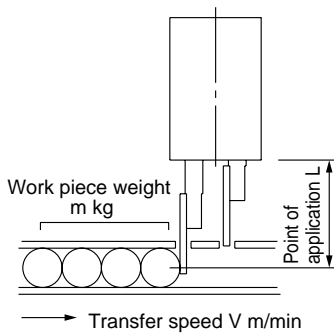

**MIW8
MIS8**

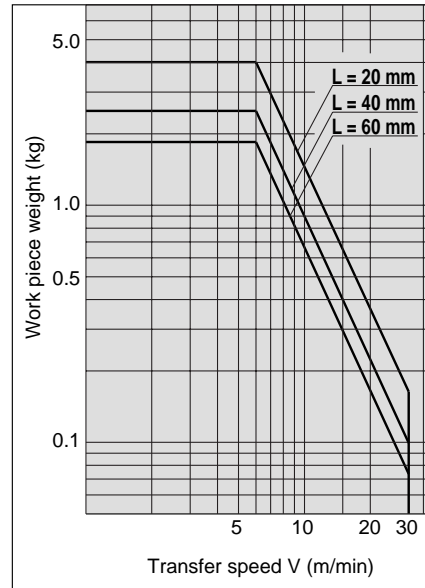

**MIW12
MIS12**

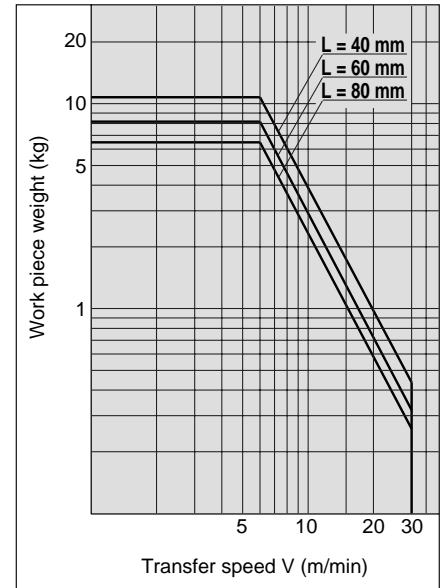

**MIW20
MIS20**

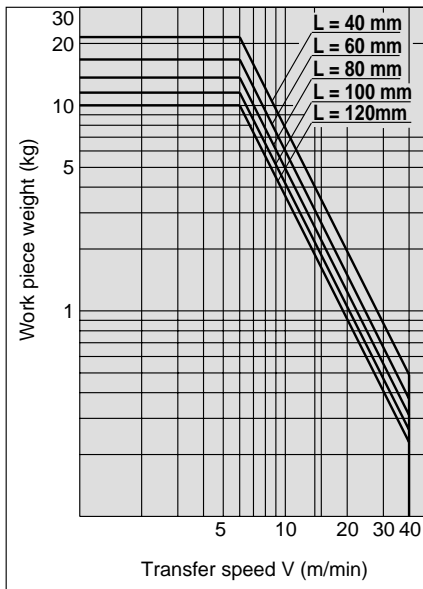

**MIW25
MIS25**

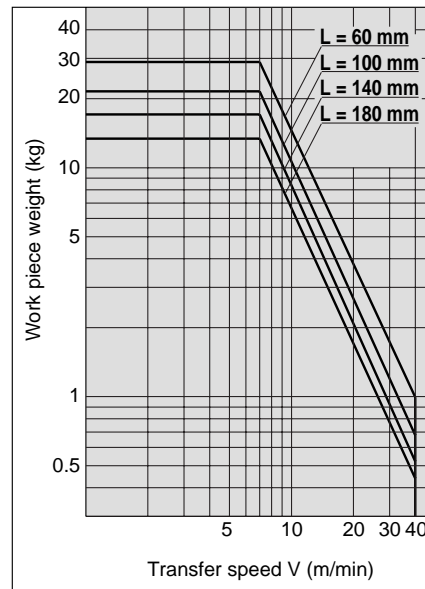

**MIW32
MIS32**

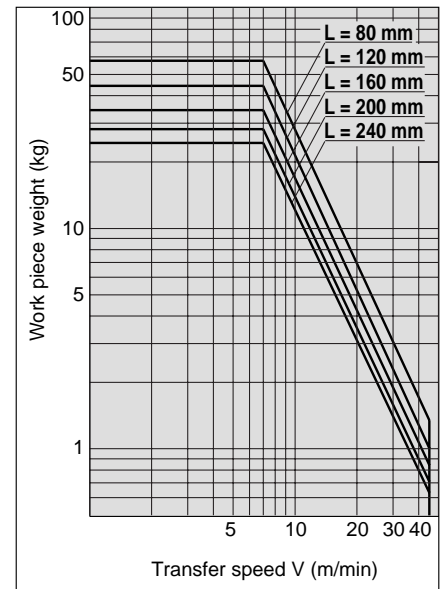

Model Selection

Allowable lateral load

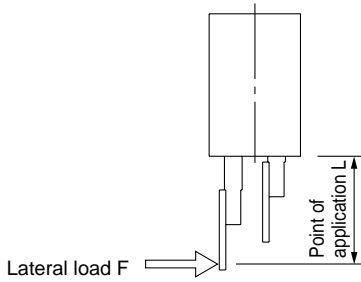

**MIW8
MIS8**

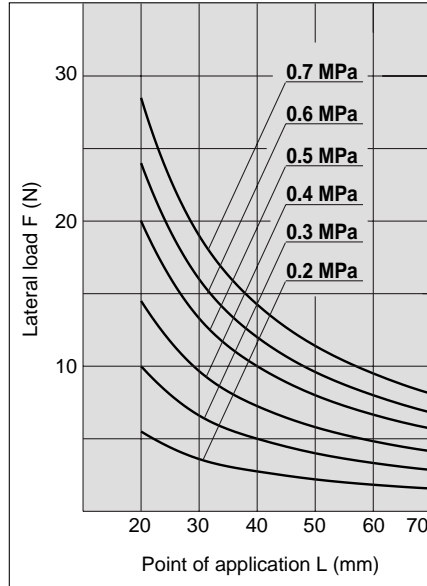

**MIW12
MIS12**

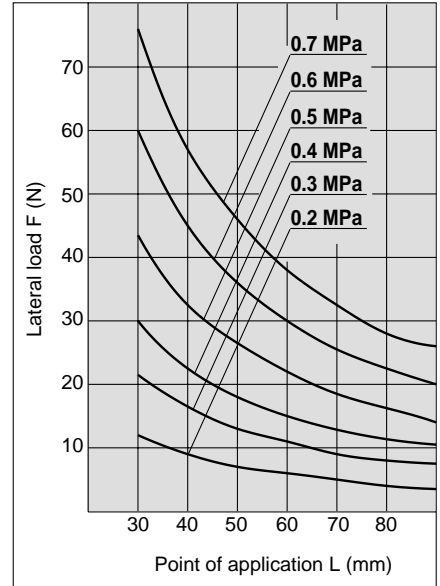

**MIW20
MIS20**

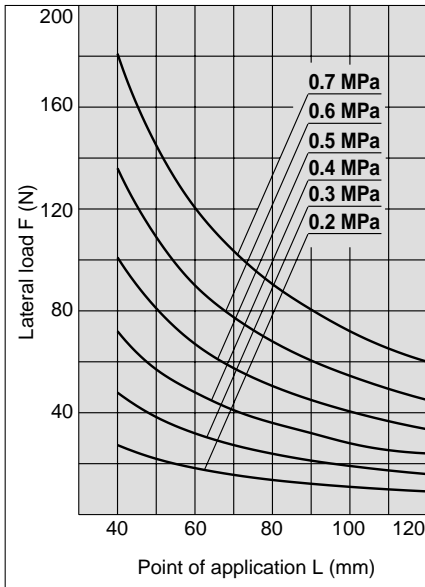

**MIW25
MIS25**

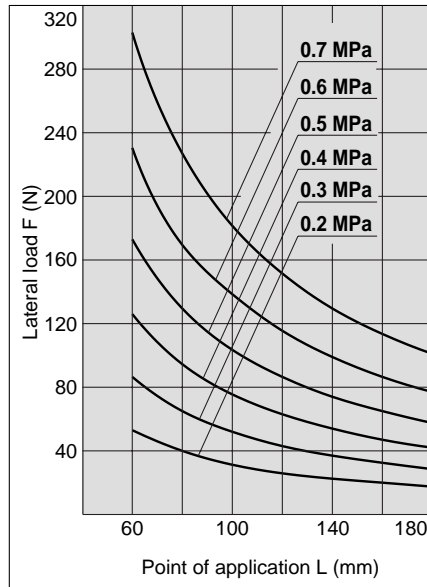

**MIW32
MIS32**

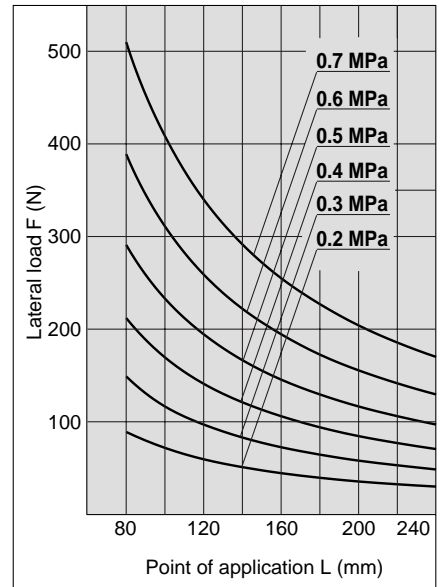

Escapements

Series MIW/MIS

ø8, ø12, ø20, ø25, ø32

How to Order

Double finger type MIW 12 [] 12 D 1 A S [] M9B []

Single finger type MIS 32 [] 50 D 1 A S [] M9B []

Cylinder bore

8	8 mm
12	12 mm
20	10 mm
25	25 mm
32	32 mm

Port thread type

Symbol	Type	Bore size
Nil	M thread	ø8, ø12
	Rc	ø20, ø25
TN	NPT	ø32
TF	G	

Stroke

* Refer to the next page for standard stroke table.

Finger options

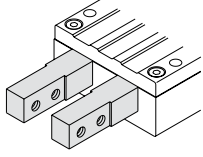
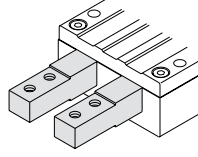
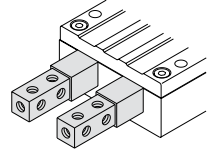
Nil: Basic type (Standard type) 	1: Tapped on upper and lower faces 	2: Tapped on all faces (5 surfaces including end surface) 
--	--	---

Scraper

Nil	No
S	Yes

Stroke adjuster

Nil	No
A	Yes

Number of auto switches

Nil	2 pcs.
S	1 pc.

Type of auto switch

Nil	Without auto switch (built-in magnet)
-----	---------------------------------------

* Refer to the table below for auto switch part numbers.

Finger options

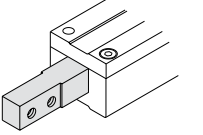
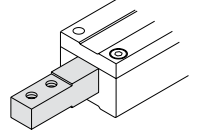
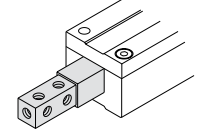
Nil: Basic type (Standard type) 	1: Tapped on upper and lower faces 	2: Tapped on all faces (5 surfaces including end surface) 
--	--	---

Applicable auto switches/Refer to pages 14 to 18 for detailed specifications of auto switches.

Type	Special function	Electrical entry	Indicator light	Wiring (output)	Load voltage		Auto switch model		Lead wire length (m)			Applicable load	
					DC	AC	Perpendicular	In-line	0.5 (Nil)	3 (L)	5 (Z)		
Solid state switch	-	Grommet	Yes	3-wire (NPN)	5 V, 12 V	-	M9NV	M9N	●	●	○	IC circuit	Relay PLC
				3-wire (PNP)			M9PV	M9P	●	●	○		
				2-wire			M9BV	M9B	●	●	○		
	Diagnostic indication (2-color display)			3-wire (NPN)	5 V, 12 V	-	F9NWV	F9NW	●	●	○	IC circuit	
				3-wire (PNP)			F9PWV	F9PW	●	●	○		
				2-wire			F9BWV	F9BW	●	●	○		

* Lead wire length symbols: 0.5 m Nil (Example) M9N
 3 m L (Example) M9NL
 5 m Z (Example) M9NZ

* Auto switches marked with a "O" symbol are produced upon receipt of order.

Made to order specifications Contact SMC.

- -50 Without indicator light
- -61 Flexible lead wire
- Pre-wire connector

Specifications



Series	MIW (Double finger)	MIS (Single finger)
Fluid	Air	
Operating pressure	0.2 to 0.7MPa	
Ambient temperature and fluid temperature	-10 to 60°C (No freezing)	
Lubrication	Non-lube	
Action	Double acting	
Auto switch (optional) ^{Note)}	Solid state switch (3-wire, 2-wire)	
Stroke tolerance	+1 0 mm	

Note) Refer to pages 14 through 18 for auto switch specification.

Option

Finger options	Standard, Tapped on upper and lower faces, Tapped on all faces (5 surfaces including end surface)
Stroke adjuster (Rear end stroke only)	MI□8 : Arrangement range 4 mm
	MI□12 : Arrangement range 6 mm
	MI□20 : Arrangement range 12 mm
	MI□25 : Arrangement range 15 mm
	MI□32 : Arrangement range 20 mm
Scraper	Can be mounted on standard products

Theoretical Output

Bore size (mm)	Rod size (mm)	Operating direction	Piston area (mm ²)	Operating pressure MPa					
				0.2	0.3	0.4	0.5	0.6	0.7
8	4	OUT	50	10	15	20	26	31	36
		IN	38	7	11	15	19	23	26
12	6	OUT	113	23	34	45	57	68	79
		IN	85	17	26	34	43	51	60
20	10	OUT	314	63	94	126	157	188	220
		IN	236	47	71	94	118	142	165
25	10	OUT	491	98	147	196	245	295	344
		IN	412	82	124	165	206	247	288
32	12	OUT	804	161	241	322	402	482	563
		IN	691	138	207	276	346	415	484

Unit: N

Standard Stroke

Double finger type/MIW (mm)

Bore size	Stroke
8	8 mm
12	12 mm
20	20 mm
25	25 mm
32	32 mm

* For MIW, same stroke as bore size

Single finger type/MIS (mm)

Bore size	Stroke
8	10, 20 mm
12	10, 20, 30 mm
20	10, 20, 30 mm
25	30, 50 mm
32	30, 50 mm

Weight

Model	Model	Stroke (mm)	Weight (g)	Increase by stroke adjuster	Increase by scraper
MIW	MIW8-8D	8	110	6	3
	MIW12-12D	12	240	10	5
	MIW20-20D	20	650	30	10
	MIW25-25D	25	1550	30	20
	MIW32-32D	32	2650	100	35
MIS	MIS8-10D	10	62	3	2
	MIS8-20D	20	80		
	MIS12-10D	10	130	5	3
	MIS12-20D	20	160		
	MIS12-30D	30	190		
	MIS20-10D	10	300	15	5
	MIS20-20D	20	355		
	MIS20-30D	30	410		
	MIS25-30D	30	800	15	10
	MIS25-50D	50	1000		
	MIS32-30D	30	1350	50	18
MIS32-50D	50	1650			

Unit: g

Series MIW/MIS

Construction/Double Finger Type (MIW)

ø8

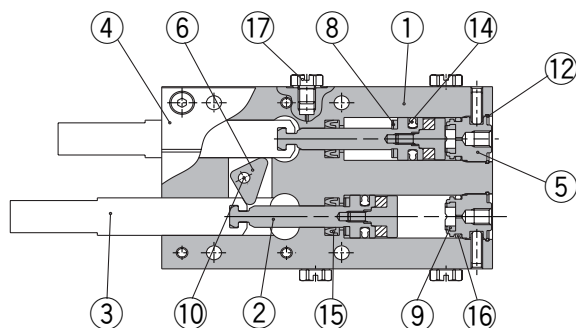

ø12, ø20

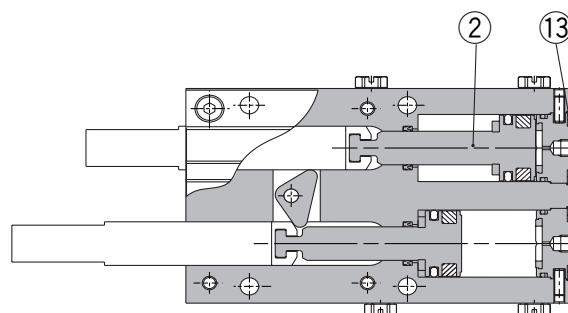

ø25, ø32

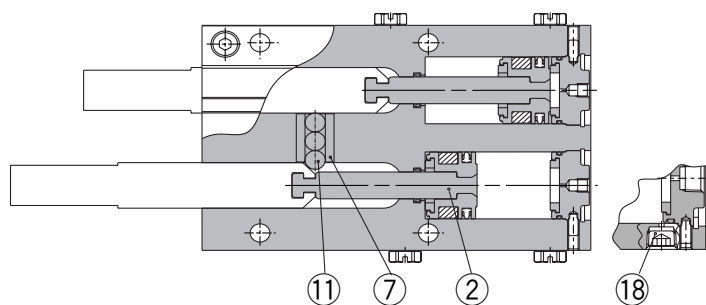

(ø32 only)

Option

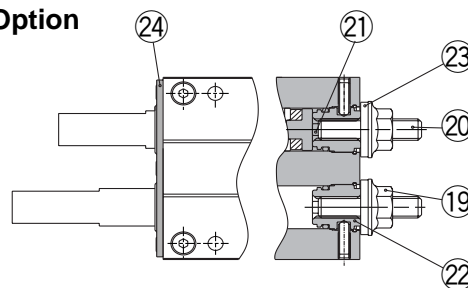

Scraper

Stroke adjuster

Component parts

No.	Description	Material	Note
1	Body	Aluminium alloy	Hard anodized
2	Piston assembly		
3	Finger	Carbon steel	Heat treatment/Special treatment
4	Cover	Aluminium alloy	Hard anodized
5	Cap (W)	Aluminium alloy	White anodized
6	Cam	Stainless steel	Heat treatment (MIW8 to 20)
7	Roller holder	Stainless steel	Heat treatment (MIW25, 32)
8	Bumper	Urethane rubber	
9	Head bumper	Urethane rubber	
10	Needle roller	High carbon chromium bearing steel	(MIW8 to 20)

No.	Description	Material	Note
11	Cylinder roller	Carbon steel	(MIW25, 32)
12	Clip	Carbon steel	(MIW8)
13	R shape snap ring	Carbon steel	(MIW12 to 32)
14	Piston seal	NBR	
15	Rod seal	NBR	
16	Gasket	NBR	
17	Plug		(MIW8 ... M-3P) (MIW12 to 25 ... M-5P)
18	Hexagon socket taper plug		(MIW32 ... Rc1/8)

Option: adjuster

No.	Description	Material	Note
19	Hexagon nut with flange	Carbon steel	Nickel plated
20	Adjustment bolt	Carbon steel	Nickel plated
21	Adjustment bumper	Urethane rubber	
22	Adjustment cap	Aluminium alloy	White anodized
23	Die thread	NBR	

Option: scraper

No.	Description	Material	Note
24	Scraper	Stainless steel + NBR	

Replacement parts

Model	Description			Seal kit	Scraper assembly	Grease pack
	Standard	Finger Tapped on upper and lower faces	Finger Tapped on all faces			
MIW8-8D	MI-A0801-8	MI-A0802-8	MI-A0803-8	MIW8-PS	MIW-A0804	MH-G01 (contents quantity 30 g)
MIW12-12D	MI-A1201-12	MI-A1202-12	MI-A1203-12	MIW12-PS	MIW-A1204	
MIW20-20D	MI-A2001-20	MI-A2002-20	MI-A2003-20	MIW20-PS	MIW-A2004	
MIW25-25D	MI-A2501-25	MI-A2502-25	MI-A2503-25	MIW25-PS	MIW-A2504	
MIW32-32D	MI-A3201-32	MI-A3202-32	MI-A3203-32	MIW32-PS	MIW-A3204	
Main parts No.	③ (1 pc.)			⑭, ⑮, ⑯	⑳	

Construction/Single Finger Type (MIS)

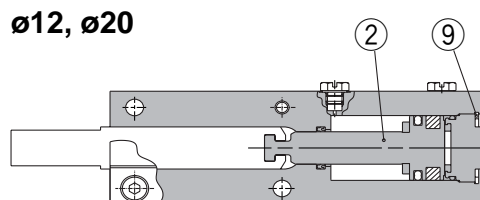
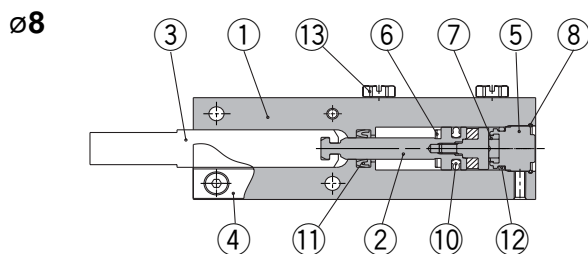

ø25, ø32

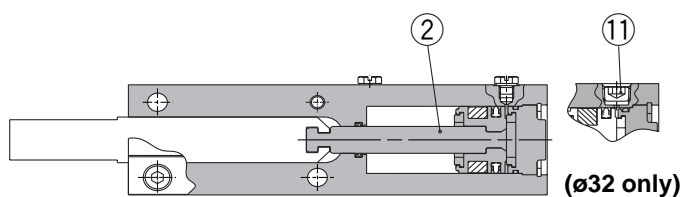

Option

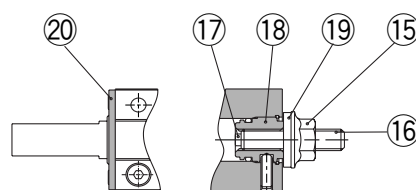

Scraper

Stroke adjuster

Component parts

No.	Description	Material	Note
1	Body	Aluminium alloy	Hard anodized
2	Piston assembly		
3	Finger	Carbon steel	Heat treatment/Special treatment
4	Cover	Aluminium alloy	Hard anodized
5	Cap (S)	Aluminium alloy	White anodized
6	Bumper	Urethane rubber	
7	Head bumper	Urethane rubber	
8	Clip	Carbon steel	(MIS8)
9	R shape snap ring	Carbon steel	(MIS12 to 32)

No.	Description	Material	Note
10	Piston seal	NBR	
11	Rod seal	NBR	
12	Gasket	NBR	
13	Plug		(MIW8 ... M-3P) (MIW12 to 25 ... M-5P)
14	Hexagon socket taper plug		(MIW32 ... Rc1/8)

Option: adjuster

No.	Description	Material	Note
15	Hexagon nut with flange	Carbon steel	Nickel plated
16	Adjustment bolt	Carbon steel	Nickel plated
17	Adjustment bumper	Urethane rubber	
18	Adjustment cap	Aluminium alloy	White anodized
19	Die thread	NBR	

Option: scraper

No.	Description	Material	Note
20	Scraper	Stainless steel + NBR	

Replacement parts

Model	Description			Seal kit	Scraper assembly	Grease pack
	Standard	Finger				
		Tapped on upper and lower faces	Tapped on all faces			
MIS8-10D	MI-A0801-10	MI-A0802-10	MI-A0803-10	MIS8-PS	MIS-A0804	MH-G01 (contents quantity 30 g)
MIS8-20D	MI-A0801-20	MI-A0802-20	MI-A0803-20			
MIS12-10D	MI-A1201-10	MI-A1202-10	MI-A1203-10			
MIS12-20D	MI-A1201-20	MI-A1202-20	MI-A1203-20	MIS12-PS	MIS-A1204	
MIS12-30D	MI-A1201-30	MI-A1202-30	MI-A1203-30			
MIS20-10D	MI-A2001-10	MI-A2002-10	MI-A2003-10			
MIS20-20D	MI-A2001-20	MI-A2002-20	MI-A2003-20	MIS20-PS	MIS-A2004	
MIS20-30D	MI-A2001-30	MI-A2002-30	MI-A2003-30			
MIS25-30D	MI-A2501-30	MI-A2502-30	MI-A2503-30			
MIS25-50D	MI-A2501-50	MI-A2502-50	MI-A2503-50	MIS25-PS	MIS-A2504	
MIS32-30D	MI-A3201-30	MI-A3202-30	MI-A3203-30			
MIS32-50D	MI-A3201-50	MI-A3202-50	MI-A3203-50			
Main parts No.	③ (1 pc.)			⑩, ⑪, ⑫	⑳	

Series MIW/MIS

Dimensions/Double Finger Type

MIW□-□D

Supply ports are provided on both sides, and on cap side.
Ports on both sides are sealed with plug at the time of shipment.

ø8 : Plug part no. M-3P (Width across flats 5)

ø12 to ø25: Plug part no. M-5P (Width across flats 7)

ø32 : Hexagon socket head taper plug
(Width across flats 5)

* Refer to the Figure 1 for G thread

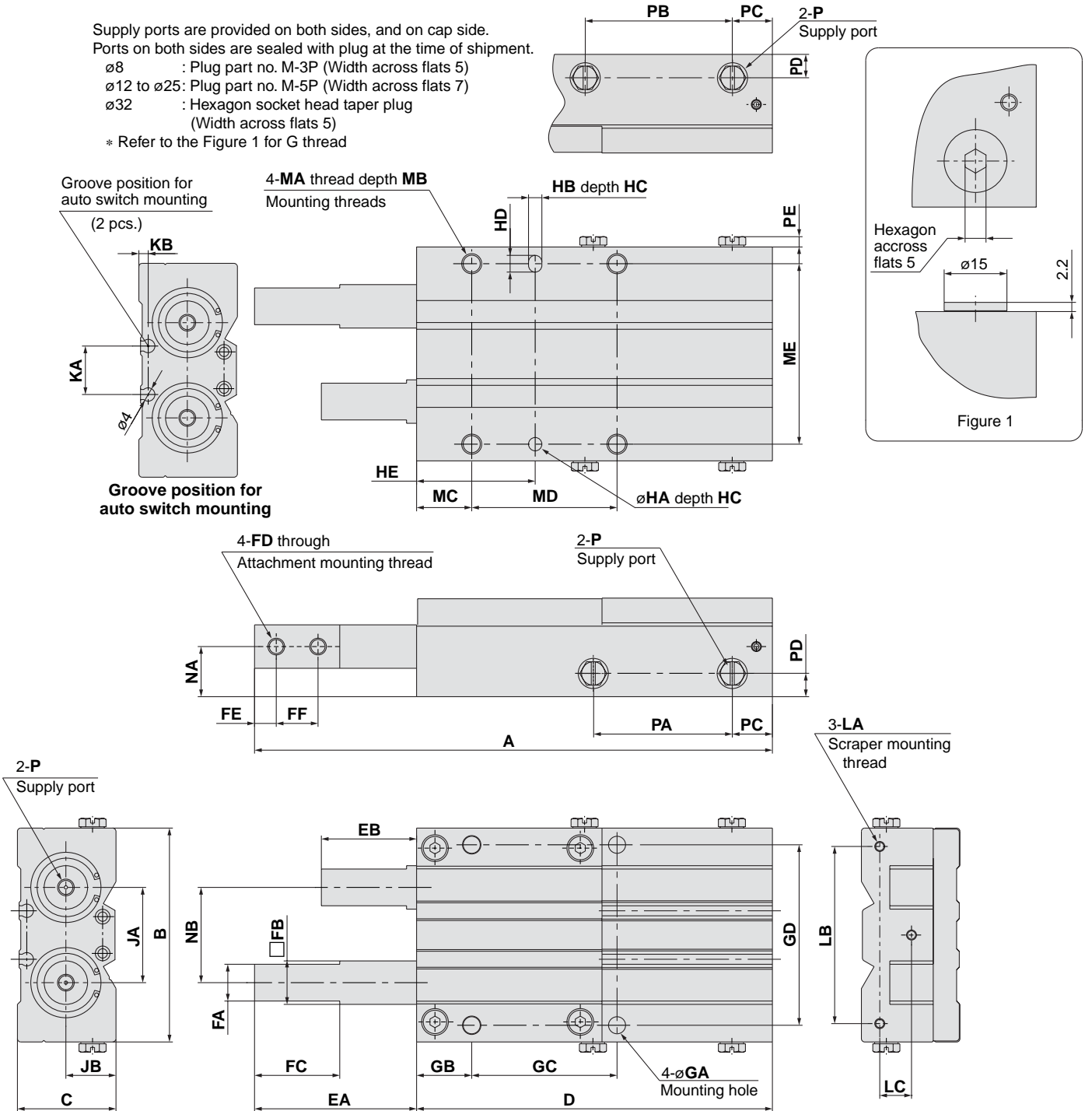

(mm)

Model	A	B	C	D	EA	EB	FA	FB	FC	FD	FE	FF	FG	GA	GB	GC	GD
MIW8-8	83	34	16	57	26	18	6 ^{-0.1} ₀	7h9 ⁰ _{-0.036}	15	M3	4	7	6 (Effective depth 2.5)	2.6	9	22	28
MIW12-12	111	44	21	76	35	23	8 ^{-0.1} ₀	10h9 ⁰ _{-0.036}	19	M3	4.5	9.5	6 (Effective depth 3)	3.3	12.5	34	37
MIW20-20	155	64	29.5	106.5	48.5	28.5	11 ⁰ _{-0.1}	13h9 ⁰ _{-0.043}	25.5	M5	6.5	12.5	10 (Effective depth 4)	5.1	16.5	43.5	54
MIW25-25	200	84	40	134	66	41	15 ^{-0.1} ₀	17h9 ⁰ _{-0.043}	37	M6 x 1	10	17	15 (Effective depth 7)	6.8	20	58	71
MIW32-32	256	95	47	169	87	55	19.5 ^{-0.1} ₀	21h9 ⁰ _{-0.052}	51	M8	12.5	22	17 (Effective depth 8.5)	8.6	24.5	73	80

Model	HA, HB	HC	HD	HE	JA	JB	KA	KB	LA	LB
MIW8-8	2H9 ^{+0.025} ₀	2	3	15	14.5	7.5	20.3	1.6	M2	28.4
MIW12-12	2.5H9 ^{+0.025} ₀	4	3.5	25	19	11	7.6	2.2	M2.6 x 0.45	37
MIW20-20	4H9 ^{+0.030} ₀	5	5	35.3	28.5	15	14.5	2.8	M3	53
MIW25-25	5H9 ^{+0.030} ₀	5	7	40	35.5	20	24.5	3	M3	70
MIW32-32	6H9 ^{+0.030} ₀	6	8	50	44.5	25	24.1	2.5	M4	81

Finger options

Tapped on upper and lower faces

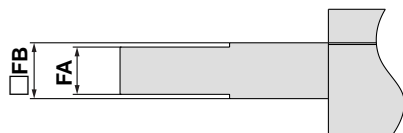

4-FD through
Attachment mounting thread

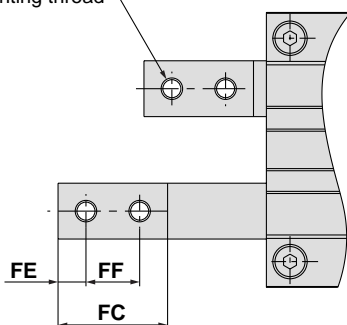

Tapped on all faces

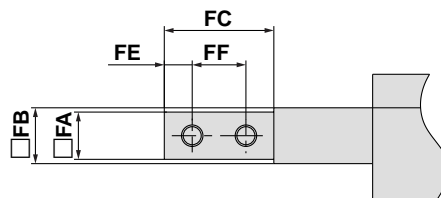

8-FD through
Attachment mounting thread

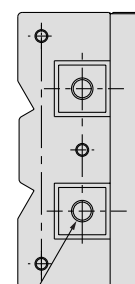
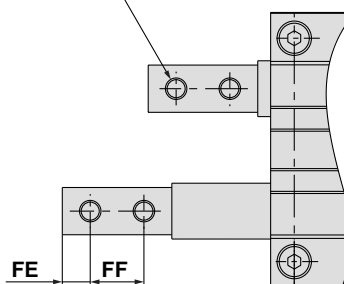

2-FD thread depth FG
Attachment mounting thread

Stroke adjuster

Note) Observe the specified adjustment range when adjusting with a stroke adjuster.

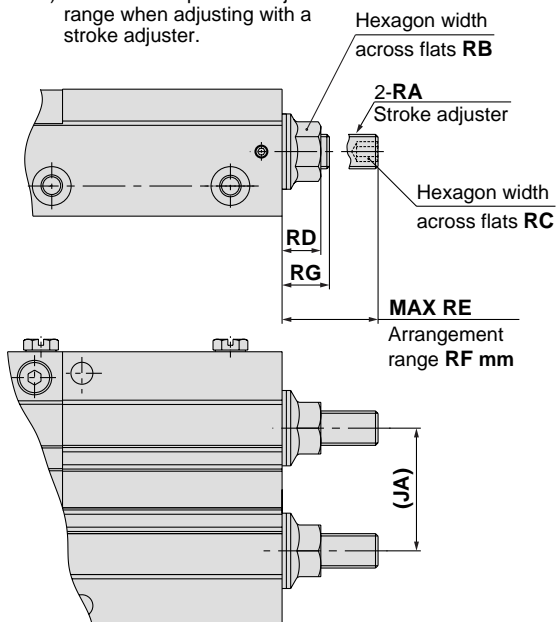

Scraper

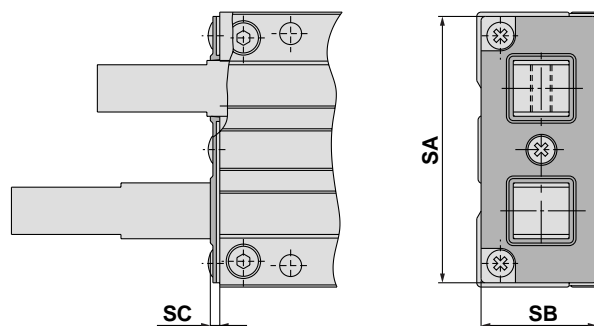

Model	LC	MA	MB	MC	MD	ME	NA	NB	P	PA	PB	PC	PD	PE	RA	RB	RC	RD
MIW8-8	4.5	M3	6	9	22	28	7.5	14.5	M3	22.5	24	8	4.5	2.2	M4	7	2	5.7
MIW12-12	7.5	M4	7	12.5	34	37	11	19	M5	25	27	10	6	2.8	M5	8	2.5	6
MIW20-20	9.5	M6	10	16.5	43.5	54	15	28.5	M5	42	44.5	11.5	7	2.7	M8 x 1	12	4	9
MIW25-25	12	M8	12	20	58	71	20	35.5	M5	50	55	14	8.5	2.7	M8 x 1	12	4	9
MIW32-32	16.5	M10	15	24.5	73	80	25	44.5	Rc1/8	69.5	75.5	14.5	11	—	M12 x 1.25	17	6	12.4

Model	RE	RF	RG	SA	SB	SC
MIW8-8	12.5	4	8.5	33	14.5	1.4
MIW12-12	14	6	8	43	18.5	1.8
MIW20-20	22.5	12	10.5	62	27	2.2
MIW25-25	26	15	11	82	36	2.8
MIW32-32	33	20	13	93	42	3.4

Series MIW/MIS

Dimensions/Single Finger Type

MIS□-□D

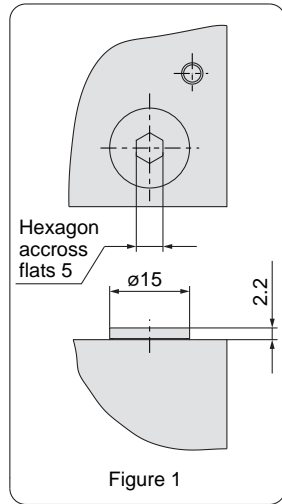

Supply ports are provided on both sides, and on cap side.
 Ports on both sides are sealed with plug at the time of shipment.
 ø8 : Plug part no. M-3P (Width across flats 5)
 ø12 to ø25: Plug part no. M-5P (Width across flats 7)
 ø32 : Hexagon socket head taper plug
 (Width across flats 5)
 * Refer to the Figure 1 for G thread

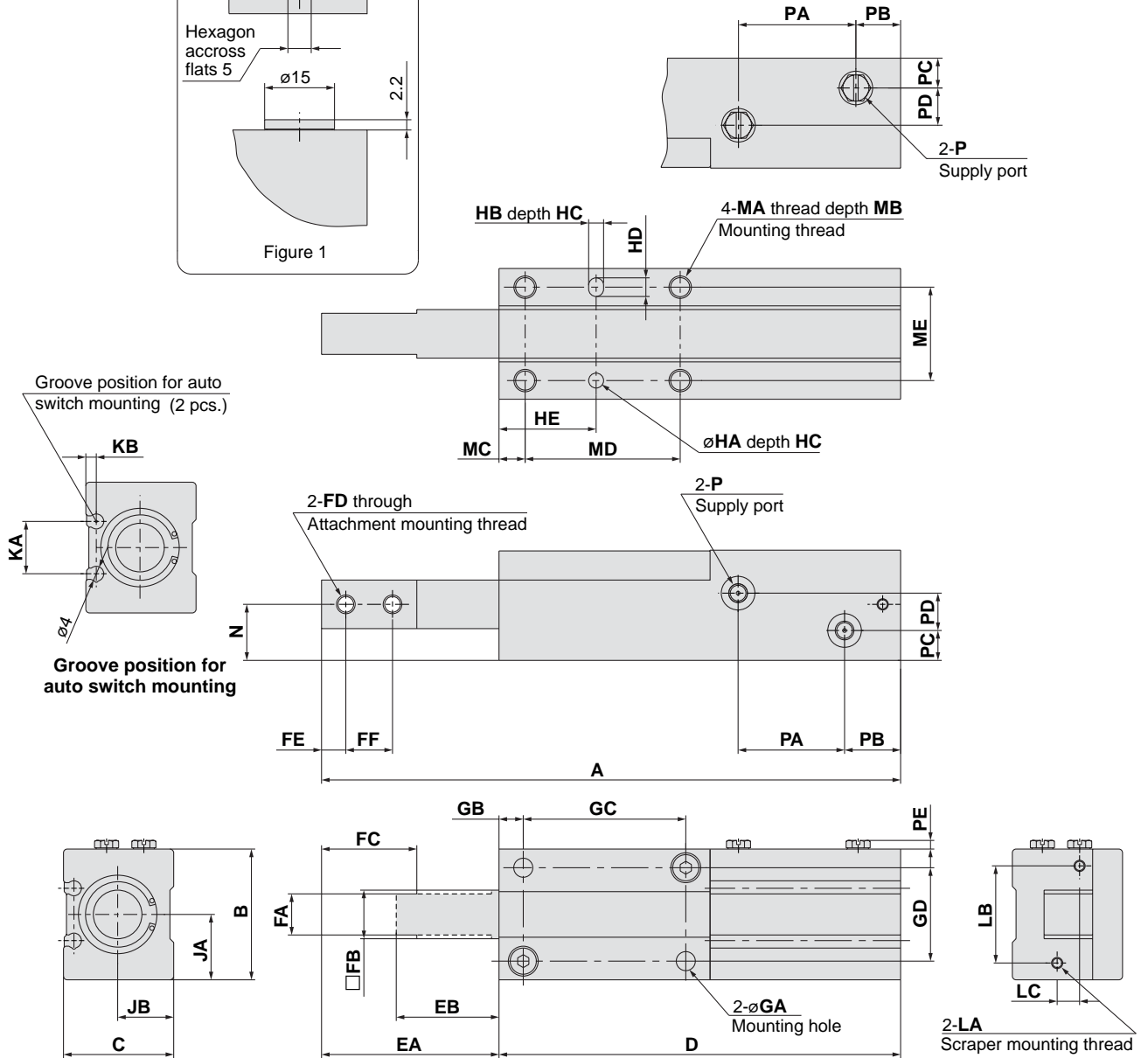

Model	A	B	C	D	EA	EB	FA	FB	FC	FD	FE	FF	FG	GA	GB	GC	GD	HA, HB
MIS8-10	87	19	16	59	28	18	6 ⁰ _{-0.1}	7h9 ⁰ _{-0.036}	15	M3	4	7	6 (Effective depth 2.5)	2.6	4	20	13	2H9 ^{+0.025} ₀
MIS8-20	117			79	38											30		
MIS12-10	105	26	21	72	33	23	8 ⁰ _{-0.1}	10h9 ⁰ _{-0.036}	19	M3	4.5	9.5	6 (Effective depth 3)	3.3	5	28	18	2.5H9 ^{+0.025} ₀
MIS12-20	135			92	43											38		
MIS12-30	165			112	53											48		
MIS20-10	125	35	29.5	86.5	38.5	28.5	11 ⁰ _{-0.1}	13h9 ⁰ _{-0.043}	25.5	M5	6.5	12.5	10 (Effective depth 4)	5.1	7	32	25	4H9 ^{+0.030} ₀
MIS20-20	155			106.5	48.5											42		
MIS20-30	185			126.5	58.5											52		
MIS25-30	215	41	40	144	71	41	15 ⁰ _{-0.1}	17h9 ⁰ _{-0.043}	37	M6	10	17	15 (Effective depth 7)	6.8	10	55	28	5H9 ^{+0.030} ₀
MIS25-50	270			184	91											75		
MIS32-30	250	50	47	165	85	55	19.5 ⁰ _{-0.1}	21h9 ⁰ _{-0.052}	51	M8	12.5	22	17 (Effective depth 8.5)	8.6	12	64	34	6H9 ^{+0.030} ₀
MIS32-50	310			205	105											84		

Finger options

Tapped on upper and lower faces

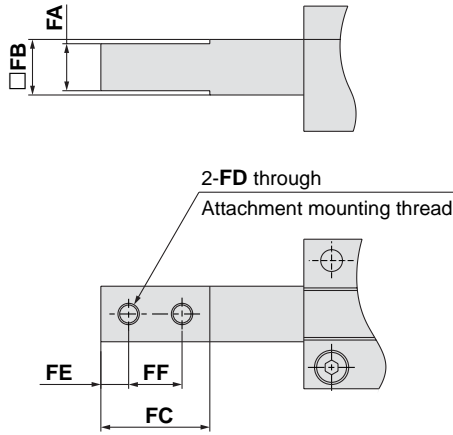

Tapped on all faces

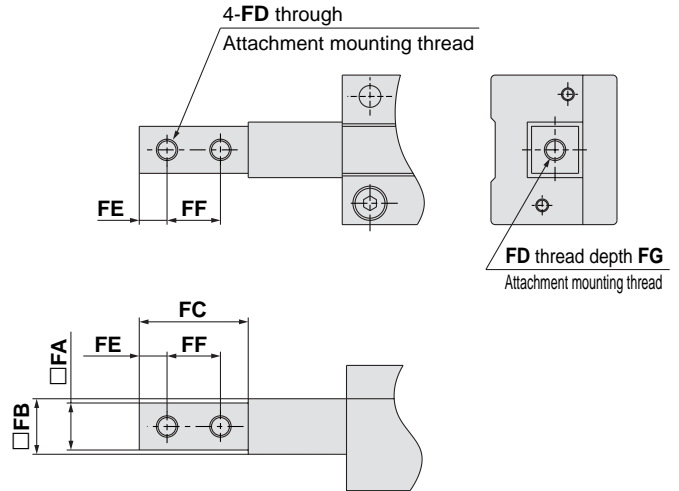

With adjuster

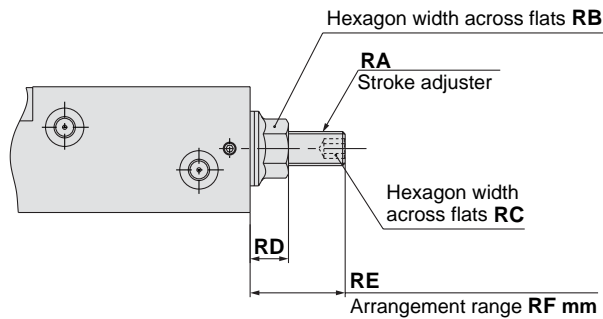

With scraper

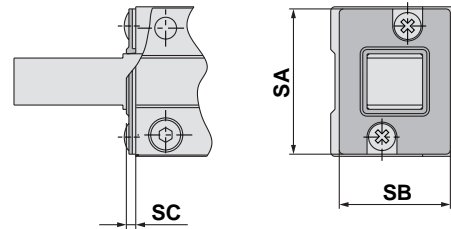

Note) Observe the specified adjustment range when adjusting with a stroke adjuster.

Model	HC	HD	HE	JA	JB	KA	KB	LA	LB	LC	MA	MB	MC	MD	ME	N	P	PA	PB	PC
MIS8-10	2	3	14	9.5	7.5	6.2	1.6	M2	14	3	M3 x 0.5	5	4	20	13	7.5	M3	19	8	4.5
MIS8-20														30				29		
MIS12-10														28				19		
MIS12-20	4	3.5	17.5	13	11	11.6	2.2	M2.6 x 0.45	19	4	M4 x 0.7	7	5	38	18	11	M5	29	10	6
MIS12-30														48				39		
MIS20-10														32				20.5		
MIS20-20	5	5	26	17.5	15	14	2.8	M3	26	6	M6 x 1	10	7	42	25	15	M5	30.5	12	8
MIS20-30														52				40.5		
MIS25-30	5	7	32	20.5	20	11	3	M3	32	10	M8 x 1.25	14	10	55	28	20	M5	47	14	12
MIS25-50														75				67		
MIS32-30	6	8	40	25	25	20.4	2.5	M4	39	12	M10 x 1.5	15	12	64	34	25	Rc1/8	47	14.5	11
MIS32-50														84				67		

Model	PD	PE	RA	RB	RC	RD	RE	RF	RG	SA	SB	SC
MIS8-10	6	2.2	M4	7	2	5.7	12.5	4	8.5	18.6	14	1.4
MIS8-20												
MIS12-10												
MIS12-20	7	2.8	M5	8	2.5	6	14	6	8	24	18	1.8
MIS12-30												
MIS20-10												
MIS20-20	10	2.7	M8 x 1	12	4	9	22.5	12	10.5	34	26	2.2
MIS20-30												
MIS25-30	14	2.7	M8 x 1	12	4	9	26	15	11	40	36	2.8
MIS25-50												
MIS32-30	27	—	M12 x 1.25	17	6	12.4	33	20	13	49	41	3.4
MIS32-50												

Series MIW/MIS

Auto Switch Mounting

When mounting an auto switch, insert the switch in the switch mounting groove on the escapement from the direction as below figure. Having set the mounting position, tighten the attached switch mounting screws with a flat head watchmakers screw driver.

* When adjusting the auto switch mounting screws, use a watchmakers screw driver with a handle 5 to 6 mm in diameter. (This is to prevent fracture due to an excessive torque.)
The guideline of the tightening torque is 0.05 to 0.1 Nm. Turn another 90° from the position where tightening is felt by hand.

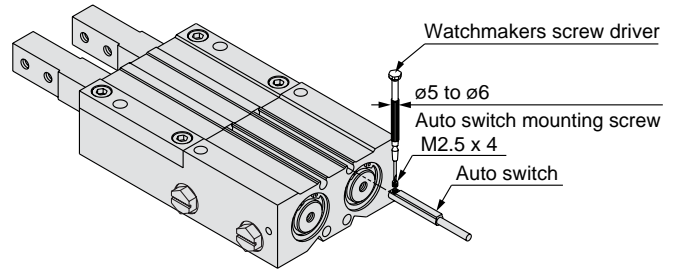

Proper mounting position for stroke end detection

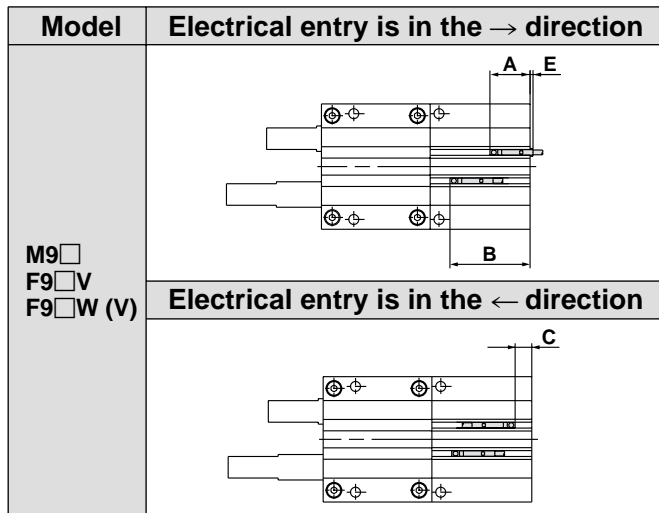

Auto Switch Operating Range

MIW/MIS	(mm)				
Auto switch model	ø8	ø12	ø20	ø25	ø32
D-M9□	2	2	2.5	3.5	4.5
D-F9□W (V)	2.5	3	3.5	5	5.5
D-F9□V					

Note) The operating ranges are provided as guidelines including hysteresis and are not guaranteed values (with ±30% variations). Hysteresis may fluctuate due to the operating environments.

Model	Proper mounting position		Model	Proper mounting position		Model	Proper mounting position	
	D-M9□ D-F9□W	D-M9□V D-F9□WV		D-M9□ D-F9□W	D-M9□V D-F9□WV		D-M9□ D-F9□W	D-M9□V D-F9□WV
MIW8-8D	A	16.5	MIS12-30D	A	18.5	MIS25-30D	A	7.5
	B	25		B	49		B	38
	C	4.5		C	6.5		C	21
	D	—		D	—		D	—
	E	6 4		E	3.5 1.5		E	— —
MIS8-10D	A	16.5	MIW20-20D	A	20.5	MIS25-50D	A	7.5
	B	27		B	41		B	38
	C	4.5		C	8.5		C	21
	D	—		D	—		D	—
	E	6 4		E	4 2		E	— —
MIS8-20D	A	16.5	MIS20-10D	A	20.5	MIW32-32D	A	8.5
	B	37		B	31		B	41
	C	4.5		C	8.5		C	29
	D	—		D	—		D	—
	E	6 4		E	4 2		E	— —
MIW12-12D	A	18.5	MIS20-20D	A	20.5	MIS32-30D	A	8.5
	B	31		B	51		B	39
	C	6.5		C	8.5		C	29
	D	—		D	—		D	—
	E	3.5 1.5		E	4 2		E	— —
MIS12-10D	A	18.5	MIS20-30D	A	20.5	MIS32-50D	A	8.5
	B	29		B	61		B	59
	C	6.5		C	8.5		C	29
	D	—		D	—		D	—
	E	3.5 1.5		E	4 2		E	— —
MIS12-20D	A	18.5	MIW25-25D	A	7.5			
	B	39		B	33			
	C	6.5		C	21			
	D	—		D	—			
	E	3.5 1.5		E	— —			

Series MIW/MIS Auto Switch Common Specifications

Auto Switch Common Specifications

Type	Solid state switch
Operating time	1 ms or less
Impact resistance	1000 m/s ²
Insulation resistance	50 MΩ or more at 500 mega VDC (between lead wire and case)
Withstand voltage	1000 VAC for 1min. (between lead wire and case)
Ambient temperature	-10 to 60°C
Enclosure	IEC529 standard IP67 JISC0920 watertight construction

Lead Wire Length

Lead wire length indication

(Example)

D-M9P **L**

● Lead wire length

Nil	0.5 m
L	3 m
Z	5 m

- Note 1) Lead wire length Z: Auto switch applicable to 5m length
Solid state switches: All models produced upon receipt of order (standard procedure).
- Note 2) The water resistant 2-colour solid state switch uses a 3 m lead wire as standard. (0.5 m is not available.)
- Note 3) For solid state with flexible wire specification, add "-61" after the lead wire length.
- Note 4) D-M9□ type use flexible wire as standard.

Lead Wire Colour Change

Lead wire colours of SMC auto switches have been changed as shown in the tables below starting from production in September 1996, in order to meet the IEC947-5-2 standard.

Take special care regarding wire polarity during the time when the old colors still coexist with the new colours.

2-wire

	Old	New
Output (+)	Red	Brown
Output (-)	Black	Blue

3-wire

	Old	New
Power supply +	Red	Brown
Power supply GND	Black	Blue
Output	White	Black

Solid state with diagnostic output

	Old	New
Power supply +	Red	Brown
Power supply GND	Black	Blue
Output	White	Black
Diagnostic output	Yellow	Orange

Solid state with latch type diagnostic output

	Old	New
Power supply +	Red	Brown
Power supply GND	Black	Blue
Output	White	Black
Latch type diagnostic output	Yellow	Orange

How to Mount Auto Switch

Point "a" is the ON position when moving switch from head side of the cylinder.

Point "b" is the ON position when moving switch from rod side of the cylinder.

Point "c", center of point "a" and "b", is the proper mounting position.

* If switch is mounted in the center between ON position and OFF position, the switch will not be on the proper position due to the hysteresis.

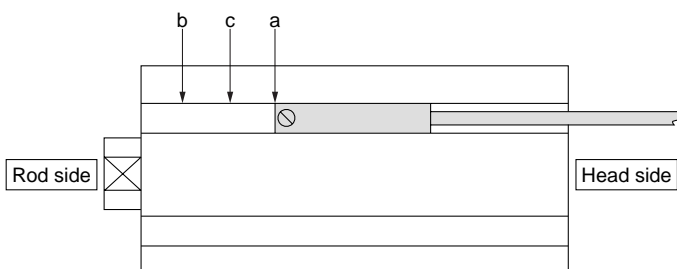

Series MIW/MIS

Auto Switch Connections and Examples

Basic Wiring

Solid state 3-wire, NPN

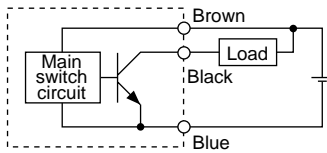

(Power supplies for switch and load are separate.)

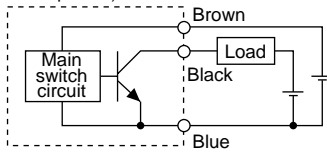

Solid state 3-wire, PNP

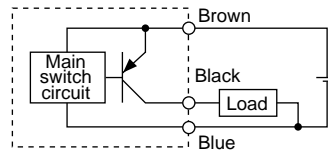

2-wire

<Solid state>

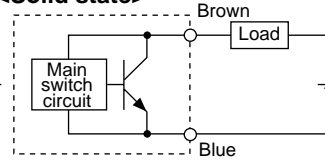

2-wire

<Reed switch>

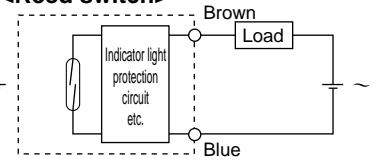

Examples of Connection to PLC

• Sink input specification 3-wire, NPN

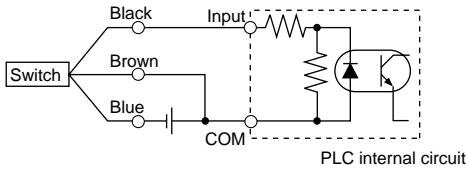

• Source input specification 3-wire, PNP

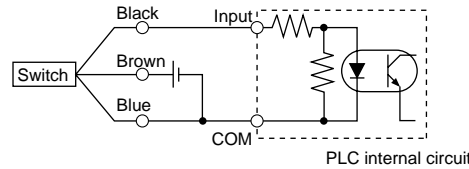

Connect according to the applicable PLC input specifications, as the connection method will vary depending on the PLC input specifications.

2-wire

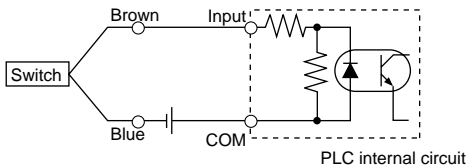

2-wire

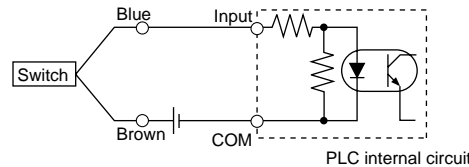

Connection Examples for AND (Series) OR (Parallel)

• 3-wire

AND connection for NPN output (using relays)

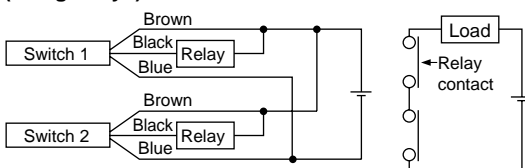

AND connection for NPN output (performed with switches only)

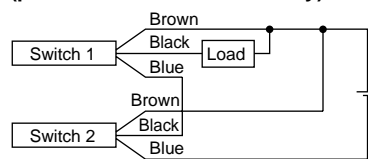

OR connection for NPN output

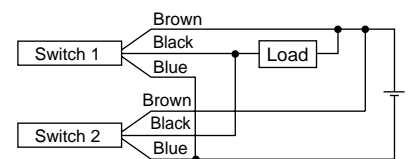

The indicator lights will light up when both switches are turned ON.

2-wire with 2 switch AND connection

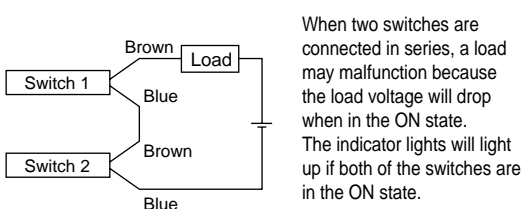

When two switches are connected in series, a load may malfunction because the load voltage will drop when in the ON state. The indicator lights will light up if both of the switches are in the ON state.

$$\begin{aligned} \text{Load voltage at ON} &= \text{Power supply voltage} - \text{Internal voltage drop} \times 2 \text{ pcs.} \\ &= 24 \text{ V} - 4 \text{ V} \times 2 \text{ pcs.} \\ &= 16 \text{ V} \end{aligned}$$

Example: Power supply is 24 VDC
Internal voltage drop in switch is 4 V

2-wire with 2 switch OR connection

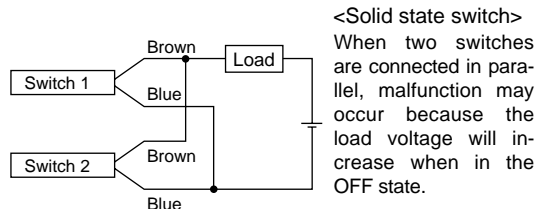

<Solid state switch>
When two switches are connected in parallel, malfunction may occur because the load voltage will increase when in the OFF state.

<Reed switch>
Because there is no current leakage, the load voltage will not increase when turned OFF. However, depending on the number of switches in the ON state, the indicator lights may sometimes get dark or not light up, because of dispersion and reduction of the current flowing to the switches.

$$\begin{aligned} \text{Load voltage at OFF} &= \text{Leakage current} \times 2 \text{ pcs.} \times \text{Load impedance} \\ &= 1 \text{ mA} \times 2 \text{ pcs.} \times 3 \text{ k}\Omega \\ &= 6 \text{ V} \end{aligned}$$

Example: Load impedance is 3 kΩ
Leakage current from switch is 1 mA

Solid State Auto Switches/Direct Mount Type D-M9N, D-M9P, D-M9B



Refer to www.smcworld.com for details of products compatible with overseas standards.

Grommet

- 2-wire load current is reduced (2.5 to 40 mA).
- Lead-free
- Use of lead wire compliant with UL standards (style 2844)



⚠ Caution

Operating Precautions

When the cable sheath is stripped, confirm the stripping direction. The insulator may be split or damaged depending on the direction.

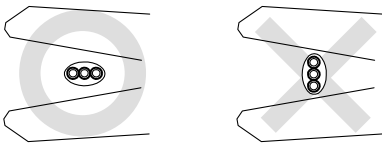

Auto Switch Internal Circuit

D-M9N

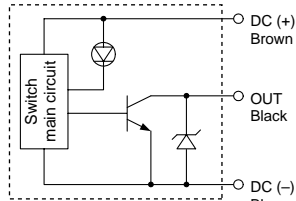

D-M9P

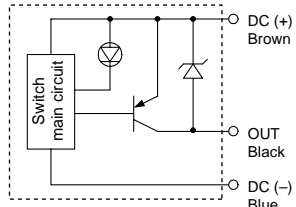

D-M9B

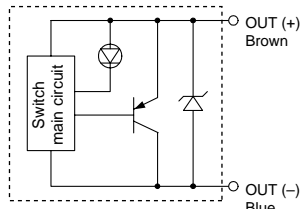

Auto Switch Specifications

PLC: Programmable Logic Controller

D-M9□ (with indicator light)			
Auto switch model	D-M9N	D-M9P	D-M9B
Wiring type	3-wire		2-wire
Output type	NPN	PNP	—
Applicable load	IC circuit, Relay, PLC		24 VDC relay, PLC
Power supply voltage	5, 12, 24 VDC (4.5 to 28 V)		—
Current consumption	10 mA or less		—
Load voltage	28 VDC or less	—	24 VDC (10 to 28 VDC)
Load current	40 mA or less		2.5 to 40 mA
Internal voltage drop	0.8 V or less		4 V or less
Leakage current	100 μA or less at 24 VDC		0.8 mA or less
Indicator light	Red LED lights when ON		

- Lead wire Oil proof heavy duty vinyl cable: 2.7 x 3.2 ellipse
 D-M9B 0.15 mm² x 2 cores
 D-M9N, D-M9P 0.15 mm² x 3 cores

Note 1) Refer to page 14 for auto switch common specifications.

Note 2) Refer to page 14 for lead wire lengths.

Weight

Unit: g

Auto switch model	D-M9N	D-M9P	D-M9B
Lead wire length (m)	0.5	8	7
	3	41	38
	5	68	63

Dimensions

D-M9□ D-M9B, N, P common

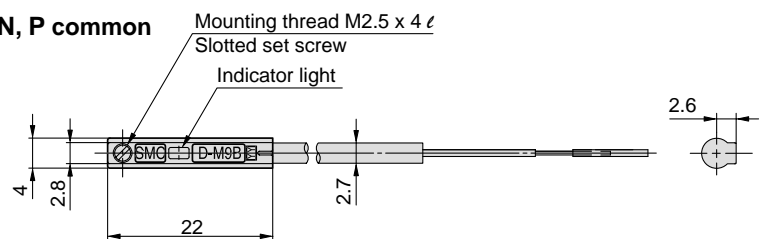

D-M9N, P (3-wire)

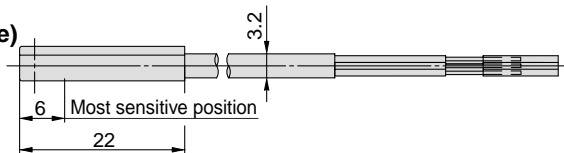

D-M9B (2-wire)

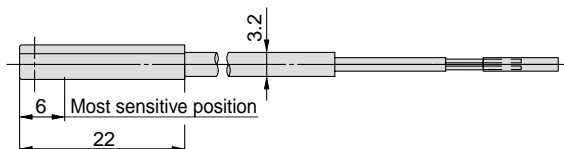

Solid State Auto Switches/Direct Mount Type D-M9NV, D-M9PV, D-M9BV C €



Refer to www.smcworld.com for details of products compatible with overseas standards.

Auto Switch Specifications

PLC: Programmable Logic Controller

D-M9□V (with indicator light)			
Auto switch model	D-M9NV	D-M9PV	D-M9BV
Electrical direction	Perpendicular	Perpendicular	Perpendicular
Wiring type	3-wire		2-wire
Output type	NPN	PNP	—
Applicable load	IC circuit, Relay, PLC		24 VDC relay, PLC
Power supply voltage	5, 12, 24VDC (4.5 to 28 V)		—
Current consumption	10 mA or less		—
Load voltage	28 VDC or less	—	24 VDC (10 to 28 VDC)
Load current	40 mA or less	40 mA or less	2.5 to 40 mA
Internal voltage drop	0.8 V or less	0.8 V or less	4 V or less
Leakage current	100 μA or less at 24 VDC		0.8 mA or less
Indicator light	Red LED lights when ON		

- Lead wire Oil proof heavy duty vinyl cable, $\phi 2.7$, 3 cores (brown, black, blue), 0.15 mm², 2 cores (brown, blue), 0.18 mm², 0.5 m

Note 1) Refer to page 14 for solid state switch common specifications.

Note 2) Refer to page 14 for lead wire lengths.

Grommet



Caution

Operating Precautions

Be sure to use the attached fixing screws to secure the auto switch.

Use of screws beyond the specified range can damage the switch.

Auto Switch Internal Circuit

D-M9NV

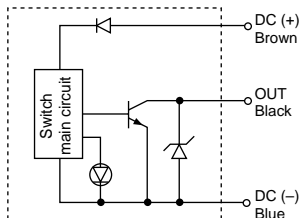

D-M9PV

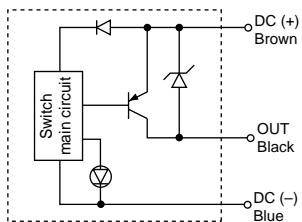

D-M9BV

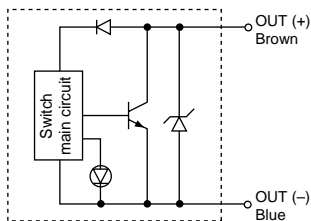

Weight

Unit: g

Auto switch model	D-M9NV	D-M9PV	D-M9BV
Lead wire length (m)	0.5	7	7
	3	37	37
	5	61	61

Dimensions

D-M9□V

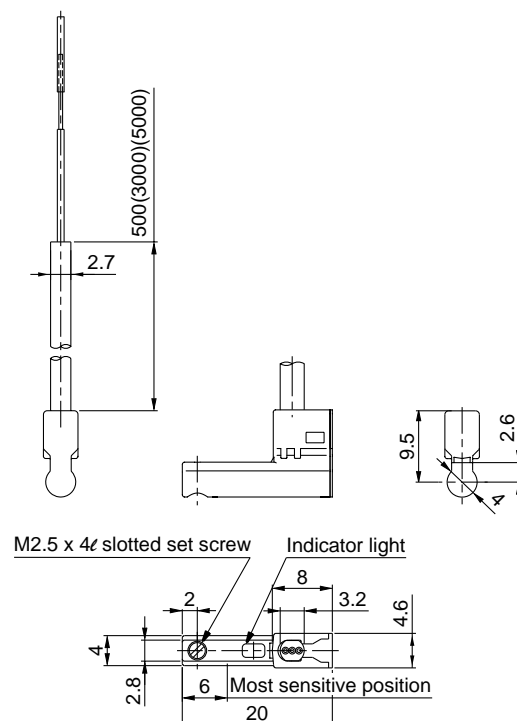

2-Color Display Solid State Auto Switches/ Direct Mount Type

D-F9NW(V), D-F9PW(V), D-F9BW(V)



Refer to www.smcworld.com for details of products compatible with overseas standards.

Auto Switch Specifications

PLC: Programmable Logic Controller

D-F9□W, D-F9□WV (with indicator light)						
Auto switch model	D-F9NW	D-F9NWV	D-F9PW	D-F9PWV	D-F9BW	D-F9BWV
Electrical entry direction	In-line	Perpendicular	In-line	Perpendicular	In-line	Perpendicular
Wiring type	3-wire				2-wire	
Output type	NPN		PNP		—	
Applicable load	IC circuit, Relay IC, PLC				24 VDC relay, PLC	
Power supply voltage	5, 12, 24 VDC (4.5 to 28 V)				—	
Current consumption	10 mA or less				—	
Load voltage	28 VDC or less		—		24 VDC (10 to 28 V)	
Load current	40 mA or less		80 mA or less		5 to 40 mA	
Internal voltage drop	1.5 V or less (0.8 V or less at 10 mA load current)		0.8 V or less		4 V or less	
Leakage current	100 μA or less at 24 VDC				0.8 mA or less	
Indicator light	Operating position Red LED lights up Optimum operating position ... Green LED lights up					

● Lead wire Oil proof heavy duty vinyl cable, $\phi 2.7$, 3 cores (brown, black, blue), 0.15 mm², 2 cores (brown, blue), 0.18 mm², 0.5 m

Note 1) Refer to page 14 for solid state switch common specifications.

Note 2) Refer to page 14 for lead wire length.

Grommet



Auto Switch Internal Circuit

D-F9NW, F9NWV

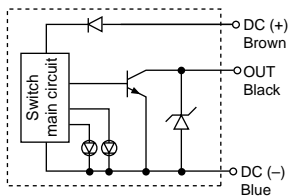

D-F9PW, F9PWV

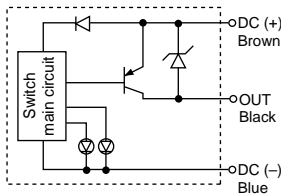

D-F9BW, F9BWV

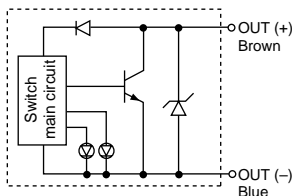

Indicator light/Display method

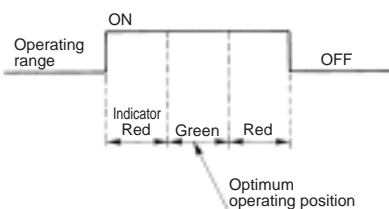

Weight

Unit: g

Auto switch model	D-F9NW(V)	D-F9PW(V)	D-F9BW(V)
Lead wire length (m)	0.5	7	7
	3	34	32
	5	56	52

Dimensions

D-F9□W

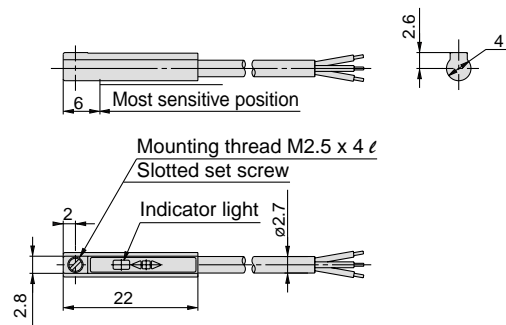

D-F9□WV

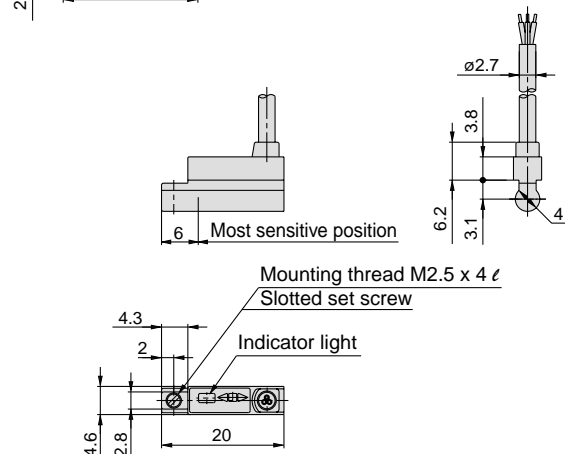





Series MIW/MIS

Safety Instructions

These safety instructions are intended to prevent a hazardous situation and/or equipment damage. These instructions indicate the level of potential hazard by a label of "**Caution**", "**Warning**" or "**Danger**". To ensure safety, be sure to observe ISO 4414 Note 1), JIS B 8370 Note 2) and other safety practices.

 **Caution** : Operator error could result in injury or equipment damage.

 **Warning** : Operator error could result in serious injury or loss of life.

 **Danger** : In extreme conditions, there is a possible result of serious injury or loss of life.

Note 1) ISO 4414: Pneumatic fluid power — General rules relating to systems

Note 2) JIS B 8370: General Rules for Pneumatic Equipment

Warning

1. The compatibility of pneumatic equipment is the responsibility of the person who designs the pneumatic system or decides its specifications.

Since the products specified here are used in various operating conditions, their compatibility for the specific system must be based on specifications or after analysis and/or tests to meet your specific requirements. The expected performance and safety assurance will be the responsibility of the person who has determined the compatibility of the system. This person should continuously review the suitability of all items specified. Referring to the latest catalogue information with a view to giving due consideration to any possibility of equipment failure when configuring a system.

2. Only trained personnel should operate pneumatically operated machinery and equipment.

Compressed air can be dangerous if handled incorrectly. Assembly, handling or repair of pneumatic systems should be performed by trained and experienced operators.

3. Do not service machinery/equipment or attempt to remove components until safety is confirmed.

1. Inspection and maintenance of machinery/equipment should only be performed once measures to prevent falling or runaway of the driven objects have been confirmed.
2. When equipment is to be removed, confirm the safety process as mentioned above. Cut the supply pressure for this equipment and exhaust all residual compressed air in the system.
3. Before machinery/equipment is restarted, take measures to prevent shooting-out of cylinder piston rod, etc.

4. Contact SMC if the product is to be used in any of the following conditions:

1. Conditions and environments beyond the given specifications, or if product is used outdoors.
2. Installation on equipment in conjunction with atomic energy, railway, air navigation, vehicles, medical equipment, food and beverages, recreation equipment, emergency stop circuits, clutch and brake circuits in press applications, or safety equipment.
3. An application which has the possibility of having negative effects on people, property, or animals, requiring special safety analysis.



Series MIW/MIS

Actuator Common Precautions 1

Be sure to read before handling.

Design

⚠ Warning

1. **There is a danger of sudden action by air cylinders if sliding parts of machinery are twisted, etc., and changes in forces occur.**

In such cases, human injury may occur; e.g., by catching hands or feet in the machinery, or damage to the machinery itself may occur. Therefore, the machine should be designed to avoid such dangers.

2. **A protective cover is recommended to minimize the risk of human injury.**

If a driven object and moving parts of a cylinder pose a danger of human injury, design the structure to avoid contact with the human body.

3. **Securely tighten all stationary parts and connected parts so that they will not become loose.**

Especially when a cylinder operates with high frequency or is installed where there is a lot of vibration, ensure that all parts remain secure.

4. **A deceleration circuit or shock absorber may be required.**

When a driven object is operated at high speed or the load is heavy, a cylinder's cushion will not be sufficient to absorb the impact. Install a deceleration circuit to reduce the speed before cushioning, or install an external shock absorber to relieve the impact. In this case, the rigidity of the machinery should also be examined.

5. **Consider a possible drop in circuit pressure due to a power outage, etc.**

When a cylinder is used in a clamping mechanism, there is a danger of work pieces dropping if there is a decrease in clamping force due to a drop in circuit pressure caused by a power outage, etc. Therefore, safety equipment should be installed to prevent damage to machinery and human injury. Suspension mechanisms and lifting devices also require consideration for drop prevention.

6. **Consider a possible failure of power source.**

Measures should be taken to protect against human injury and equipment damage in the event that there is a failure of power source to equipment controlled by pneumatics, electricity or hydraulics, etc.

7. **Design circuitry to prevent sudden lurching of driven objects.**

When a cylinder is driven by an exhaust centre type directional control valve or when starting up after residual pressure is exhausted from the circuit, etc., the piston and its driven object will lurch at high speed if pressure is applied to one side of the cylinder because of the absence of air pressure inside the cylinder. Therefore, equipment should be selected and circuits designed to prevent sudden lurching, because there is a danger of human injury and/or damage to equipment when this occurs.

8. **Consider emergency stops.**

Design so that human injury and/or damage to machinery and equipment will not be caused when machinery is stopped by a safety device under abnormal conditions, such as a power outage or a manual emergency stop.

9. **Consider the action when operation is restarted after an emergency stop or abnormal stop.**

Design the machinery so that human injury or equipment damage will not occur upon restart of operation.

When the cylinder has to be reset at the starting position, install safe manual control equipment.

Selection

⚠ Warning

1. **Confirm the specifications.**

The products included in this catalogue are designed according to use in industrial compressed air systems. If the products are used in conditions where pressure and/or temperature are out of specification, damage and/or malfunction may be caused. Do not use in these conditions. (Refer to specifications.)

Consult SMC if you use a fluid other than compressed air.

2. **Intermediate stops**

When intermediate stopping of a cylinder piston is performed with a 3 position closed centre type directional control valve, it is difficult to achieve stopping positions as accurate and precise as with hydraulic pressure due to the compressibility of air.

Furthermore, since valves and cylinders are not guaranteed for zero air leakage, it may not be possible to hold a stopped position for an extended period of time. Contact SMC in case it is necessary to hold a stopped position for an extended period.

⚠ Caution

1. **Use a speed controller to adjust the cylinder drive speed, gradually increasing from a low speed to the desired speed setting.**

Mounting

⚠ Caution

1. **Do not use until you verify that equipment can operate properly.**

Following mounting, repair or conversions, verify correct mounting by suitable function and leakage tests after compressed air and power are connected.

2. **Instruction manual**

The product should be mounted and operated after thoroughly reading the manual and understanding its contents.

Keep the instruction manual where it can be referred to as needed.

Piping

⚠ Caution

1. **Preparation before piping**

Before piping is connected, it should be thoroughly blown out with air (flushing) or washed to remove chips, cutting oil and other debris from inside the pipe.

2. **Wrapping of sealant tape**

When screwing together pipes and fittings, etc., be certain that chips from the pipe threads and sealing material do not get inside the piping.

Also, when sealant tape is used, leave 1.5 to 2 thread ridges exposed at the end of the threads.

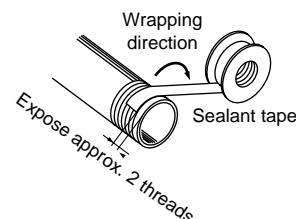



Series MIW/MIS

Actuator Common Precautions 2

Be sure to read before handling.

Lubrication

Caution

1. Lubrication of non-lube type cylinder

The cylinder is lubricated at the factory and can be used without any further lubrication.

However, in the event that it will be lubricated, use class 1 turbine oil (with no additives) ISO VG32.

Stopping lubrication later may lead to malfunction due to the loss of the original lubricant. Therefore, lubrication must be continued once it has been started.

Air Supply

Warning

1. Use clean air.

Do not use compressed air that includes chemicals, synthetic oils containing organic solvents, salt or corrosive gases, etc., as it can cause damage or malfunction.

Caution

1. Install air filters.

Install air filters at the upstream side of valves. The filtration degree should be 5 µm or finer.

2. Install an air dryer, after-cooler or water separator (drain catch), etc.

Air that includes excessive drainage may cause malfunction of valves and other pneumatic equipment. To prevent this, install an air dryer, after-cooler or water separator (drain catch), etc.

3. Use the product within the specified range of fluid and ambient temperature.

At temperatures of 5°C or lower, take measures to prevent freezing, since moisture in circuits may be frozen and this can cause damage to seals and lead to malfunction.

Refer to SMC's "Best Pneumatics vol. 4" catalogue for further details on compressed air quality.

Operating Environment

Warning

1. Do not use in environments where there is a danger of corrosion.

Refer to the construction drawings regarding cylinder materials.

2. When using auto switches, do not operate in an environment with strong magnetic fields.

Maintenance

Warning

1. Perform maintenance according to the procedure indicated in the instruction manual.

If handled improperly, malfunction and damage of machinery or equipment may occur.

2. Removal of equipment, and supply/exhaust of compressed air

When machinery is removed, first check measures to prevent dropping of driven objects and run-away of equipment, etc. Then cut off the supply pressure and electric power, and exhaust all compressed air from the system.

When machinery is restarted, proceed with caution after confirming measures to prevent cylinder lurching.

Caution

1. Drain flushing

Drain air filters regularly.



Series MIW/MIS Specific Product Precautions 1

Be sure to read before handling.

Refer to pages 19 to 21 for safety instructions, actuator precautions and auto switch precautions.

Selection

Warning

1. Design the attachment to be light and short.

- 1) A long and heavy attachment can cause a large inertia force in operation, sometimes affecting the life time.
- 2) Design the attachment to be as short and light as possible even within the limitation.

Mounting

Warning

1. Do not scratch or gouge the escapement by dropping or bumping it when mounting.

Even a slight deformation can cause inaccuracy or malfunction.

2. Please observe the specified torque limits when tightening screws to mount the attachment.

A tightening torque beyond the specified limits can cause malfunction, while a tightening torque below the specified limits can cause dislocation or drop off.

Mounting attachment on finger

When mounting an attachment on the finger, support the finger with a tool like a spanner to prevent twisting.

Mount attachments by inserting bolts, etc. into the female mounting threads on the fingers and tightening with the torque shown in the table below.

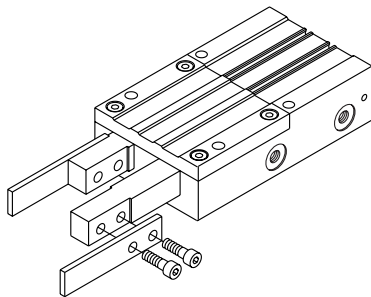

Model	Bolt	Max tightening torque (N·m)
MIW8	M3	0.88
MIS8		
MIW12	M3	0.88
MIS12		
MIW20	M5	4.3
MIS20		
MIW25	M6	7.3
MIS25		
MIW32	M8	17.5
MIS32		

3. Please observe the specified torque limits when tightening screws to mount the attachment.

A tightening torque above the specified limits can cause malfunction, while a tightening torque below the specified limits can cause dislocation or drop off.

Mounting

Mounting

Body tap

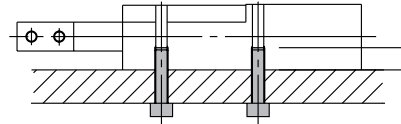

Model	Bolt	Max tightening torque (N·m)	Max screw-in depth (mm)
MIW8	M3	0.88	6
MIS8		0.63	4.5
MIW12	M4	1.5	6
MIS12			
MIW20	M6	5.2	9
MIS20			
MIW25	M8	12.5	12
MIS25			
MIW32	M10	24.5	15
MIS32			

Body through hole

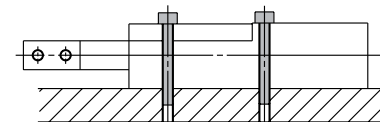

Model	Bolt	Max tightening torque (N·m)
MIW8	M2.5	0.5
MIS8		
MIW12	M3	0.88
MIS12		
MIW20	M5	4.3
MIS20		
MIW25	M6	7.3
MIS25		
MIW32	M8	17.5
MIS32		

Caution

1. When mounting an attachment on the finger, support the finger with a tool like a spanner to prevent twisting.

Otherwise malfunction may result.

2. Please do not scratch or gouge the sliding part of the finger.

It may increase the sliding resistance or cause abrasion.

3. Use a speed controller, etc. to keep the operating speed of the finger within the proper range.

Otherwise the life time may be adversely affected by inertia force of the attachment.

4. Conduct meter-out control to throttle down the speed.

Applicable speed controller

Direct connection type –AS120□ Piping type – AS1001F

Direct connection type –AS220□ Piping type – AS2001F etc.



Series MIW/MIS

Specific Product Precautions 2

Be sure to read before handling.

Refer to pages 19 to 21 for safety instructions, actuator precautions and auto switch precautions.

Changing of Piping Directions

Caution

2. Please observe the specified torque limits when tightening a plug to change the piping directions.

A tightening torque above the specified limits can cause a damage to the plug, while tightening torque below the specified limits can cause a damage to seal or the screw come loose during the operation.

Model	Port size	How to tight
MIW8 MIS8	M3 (Plug part no.: M-3P)	Turn another 1/4 turn with a tool after manual tightening.
MIW12 MIS12	M5 (Plug part no.: M-5P)	Turn another 1/6 turn with a tool after manual tightening.
MIW20 MIS20		
MIW25 MIS25		
MIW32 MIS32	Rc1/8	Tightening torque 7 to 9 N·m

Supply port operation

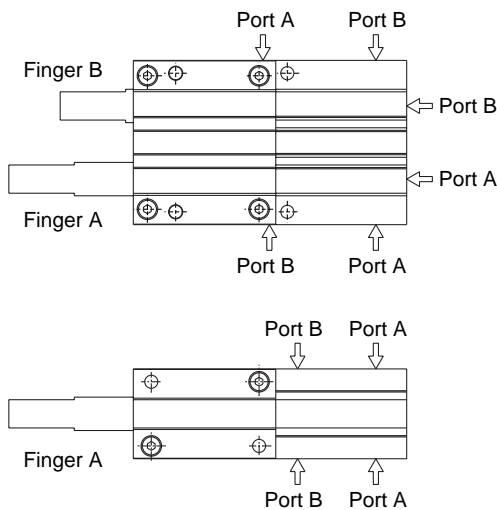

Pressured from A port → Finger A extends, finger B retracts
 Pressure from B port → Finger B extends, finger A retracts

Handling of Adjuster Options

Stroke adjuster

Warning

1. Observe the specified adjustment range as shown on right when adjusting with a stroke adjuster.

Bolts may shoot out when adjusting stroke adjuster over the maximum stroke as shown on right. Be sure to observe the specified adjustment range, otherwise malfunction may results.

Handling of Adjuster Options

Model	At the maximum stroke	At the maximum adjustment	Adjustment range
MIW8	12.5	8.4	4
MIS8			
MIW12	14	8	6
MIS12			
MIW20	22.5	10.5	12
MIS20			
MIW25	26	11	15
MIS25			
MIW32	33	13	20
MIS32			

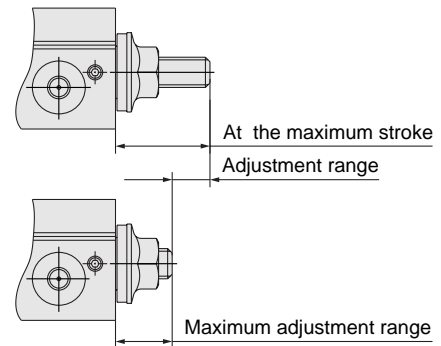

2. Be sure to use specified adjuster bolts for replacement. Otherwise, fracture may be caused by an impact etc.

3. Refer to the table below for the lock nut tightening torque.

Insufficient tightening can cause air leakage.

Model	Tightening torque (N·m)
MIW8	1.2 to 1.5
MIS8	
MIW12	2.5 to 3.0
MIS12	
MIW20	10.5 to 12.5
MIS20	
MIW25	10.5 to 12.5
MIS25	
MIW32	34 to 42
MIS32	

Operating Environment

Caution

1. Do not use in an environment where the product is directly exposed to liquid such as cutting lubricant.

Avoid use in an environment where the product is exposed to cutting lubricant, liquid coolant or oil mist. It can cause rattles, increase in sliding resistance and air leakage.

2. Do not use in an environment where the product is directly exposed to foreign matter such as dust, coarse particular, chips and polishing powder from a spatter grinder, etc.

It can cause rattles, increase in sliding resistance and air leakage.



Series MIW/MIS Specific Product Precautions 3

Be sure to read before handling.

Refer to pages 19 to 21 for safety instructions, actuator precautions and auto switch precautions.

Operating Environment

⚠ Caution

3. Provide shading in an environment where the product is exposed to the sunlight.
4. Block off heat radiation in an environment where a heat source is at a close distance.

Block off heat radiation with a cover if a heat source is at a close distance because the temperature of the product can rise to exceed the operating temperature range due to radiation.

5. Do not use in an environment where vibration or impact occurs.

Contact SMC about use under such conditions because it can cause fracture or malfunction.

Lubrication

⚠ Caution

1. The non-lubricant type escapement is lubricated at the factory and does not need further lubrication for use.

In case the product is lubricated by the customer, apply class 1 turbin oil (non additive) ISO VG32.

In case the product is lubricated by the customer, be sure to continue lubrication.

If it is discontinued, malfunction may result due to loss of initial lubricant.

Maintenance

⚠ Warning

1. Keep away hands and other body parts from the fingers of the escapement or movement range of the attachment.

It can lead to an injury or accident.

2. When removing the escapement, first block off or remove the work piece on the primary side of the escapement, release compressed air and remove it.

If the work piece remains, it can be transferred by mistake and cause failure to the equipment on the secondary side.

Finger replacement

1. Remove the hexagon socket head screws.
2. Remove the cover.
3. Replace the finger.
 - Apply the specified grease to the sliding part and T groove part of the finger.
 - Insert the piston in the T groove so that it will be hooked there.
4. Mount the cover and tighten the hexagon socket head screws with the tightening torque in the table below.

Bore size	Hexagon socket head screw	Hexagon width across flats	Tightening torque (N·m)
8	M2 x 6	1.5	0.24
12	M2.5 x 6	2	0.36
20	M4 x 10	3	1.5
25	M5 x 14	4	3.0
32	M6 x 15	5	5.2

Maintenance

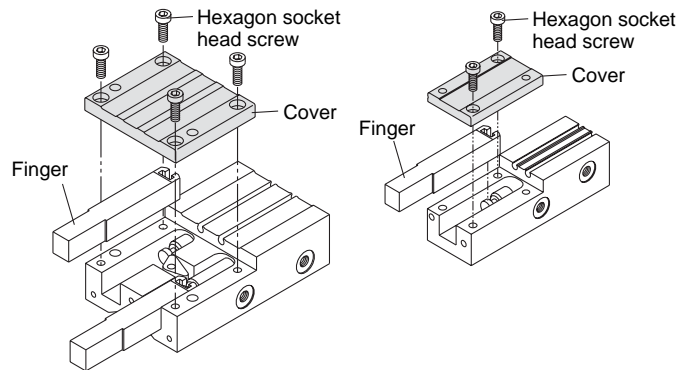

Finger and position connection

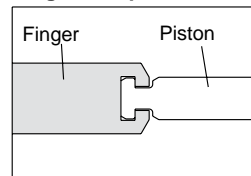

For information on the replacement parts and specified grease, refer to the replacement parts on page 7 and 8.

Scraper Option

⚠ Caution

1. Please observe the specified torque limits when mounting a scraper.

A tightening torque above the specified limits can cause a damage, while tightening torque below the specified limits can cause a dislocation or drop off.

Tightening torque

Model	Bolt (N·m)
MIW8	0.176
MIS8	
MIW12	0.36
MIS12	
MIW20	0.63
MIS20	
MIW25	0.63
MIS25	
MIW32	1.5
MIS32	

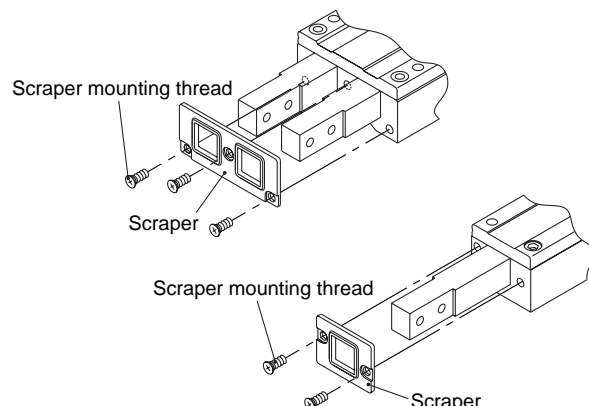



EUROPEAN SUBSIDIARIES:



Austria

SMC Pneumatik GmbH (Austria).
Girakstrasse 8, A-2100 Korneuburg
Phone: +43 2262-62280, Fax: +43 2262-62285
E-mail: office@smc.at
http://www.smc.at



France

SMC Pneumatique, S.A.
1, Boulevard de Strasbourg, Parc Gustave Eiffel
Bussy Saint Georges F-77607 Marne La Vallée Cedex 3
Phone: +33 (0)1-6476 1000, Fax: +33 (0)1-6476 1010
E-mail: contact@smc-france.fr
http://www.smc-france.fr



Netherlands

SMC Pneumatics BV
De Ruyterkade 120, NL-1011 AB Amsterdam
Phone: +31 (0)20-5318888, Fax: +31 (0)20-5318880
E-mail: info@smcpneumatics.nl
http://www.smcpneumatics.nl



Spain

SMC España, S.A.
Zuazobidea 14, 01015 Vitoria
Phone: +34 945-184 100, Fax: +34 945-184 124
E-mail: post@smc.smces.es
http://www.smces.es



Belgium

SMC Pneumatics N.V./S.A.
Nijverheidsstraat 20, B-2160 Wommelgem
Phone: +32 (0)3-355-1464, Fax: +32 (0)3-355-1466
E-mail: post@smcpneumatics.be
http://www.smcpneumatics.be



Germany

SMC Pneumatik GmbH
Boschring 13-15, D-63329 Egelsbach
Phone: +49 (0)6103-4020, Fax: +49 (0)6103-402139
E-mail: info@smc-pneumatik.de
http://www.smc-pneumatik.de



Norway

SMC Pneumatics Norway A/S
Vollsvveien 13 C, Granfos Næringspark N-1366 Lysaker
Tel: +47 67 12 90 20, Fax: +47 67 12 90 21
E-mail: post@smc-norge.no
http://www.smc-norge.no



Sweden

SMC Pneumatics Sweden AB
Ekhagsvägen 29-31, S-141 71 Huddinge
Phone: +46 (0)8-603 12 00, Fax: +46 (0)8-603 12 90
E-mail: post@smcpneumatics.se
http://www.smc.nu



Bulgaria

SMC Industrial Automation Bulgaria EOOD
16 Kliment Ohridski Blvd., fl.13 BG-1517 Sofia
Phone: +359 2 9744492, Fax: +359 2 9744519
E-mail: office@smc.bg
http://www.smc.bg



Greece

S. Parianosopoulos S.A.
7, Konstantinoupoleos Street, GR-11855 Athens
Phone: +30 (0)1-3426076, Fax: +30 (0)1-3455578
E-mail: parianos@hol.gr
http://www.smceu.com



Poland

SMC Industrial Automation Polska Sp.z.o.o.
ul. Konstruktorska 11A, PL-02-673 Warszawa,
Phone: +48 22 548 5085, Fax: +48 22 548 5087
E-mail: office@smc.pl
http://www.smc.pl



Switzerland

SMC Pneumatik AG
Dorfstrasse 7, CH-8484 Weisslingen
Phone: +41 (0)52-396-3131, Fax: +41 (0)52-396-3191
E-mail: info@smc.ch
http://www.smc.ch



Croatia

SMC Industrijska automatika d.o.o.
Crnomerec 12, 10000 ZAGREB
Phone: +385 1 377 66 74, Fax: +385 1 377 66 74
E-mail: office@smc.hr
http://www.smceu.com



Hungary

SMC Hungary Ipari Automatizálási Kft.
Budafoki út 107-113, H-1117 Budapest
Phone: +36 1 371 1343, Fax: +36 1 371 1344
E-mail: office@smc-automation.hu
http://www.smc-automation.hu



Portugal

SMC Sucursal Portugal, S.A.
Rua de Eng.ª Ferreira Dias 452, 4100-246 Porto
Phone: +351 22-610-89-22, Fax: +351 22-610-89-36
E-mail: postpt@smc.smces.es
http://www.smces.es



Turkey

Entek Pnömatik San. ve Tic Ltd. Sti.
Perpa Tic. Merkezi Kat: 11 No: 1625, TR-80270 Okmeydanı Istanbul
Phone: +90 (0)212-221-1512, Fax: +90 (0)212-221-1519
E-mail: smc-entek@entek.com.tr
http://www.entek.com.tr



Czech Republic

SMC Industrial Automation CZ s.r.o.
Hudcova 78a, CZ-61200 Brno
Phone: +420 5 414 24611, Fax: +420 5 412 18034
E-mail: office@smc.cz
http://www.smc.cz



Ireland

SMC Pneumatics (Ireland) Ltd.
2002 Citywest Business Campus, Naas Road, Saggart, Co. Dublin
Phone: +353 (0)1-403 9000, Fax: +353 (0)1-464-0500
E-mail: sales@smcpneumatics.ie
http://www.smcpneumatics.ie



Romania

SMC Romania srl
Str. Frunzei 29, Sector 2, Bucharest
Phone: +40 213205111, Fax: +40 213261489
E-mail: smccadm@canad.ro
http://www.smcromania.ro



UK

SMC Pneumatics (UK) Ltd
Vincent Avenue, Crownhill, Milton Keynes, MK8 0AN
Phone: +44 (0)800 1382930 Fax: +44 (0)1908-555064
E-mail: sales@smcpneumatics.co.uk
http://www.smcpneumatics.co.uk



Denmark

SMC Pneumatik A/S
Knudsminde 4B, DK-8300 Odder
Phone: +45 70252900, Fax: +45 70252901
E-mail: smc@smc-pneumatik.dk
http://www.smcdk.com



Italy

SMC Italia S.p.A
Via Garibaldi 62, I-20061 Carugate, (Milano)
Phone: +39 (0)2-92711, Fax: +39 (0)2-9271365
E-mail: mailbox@smcitalia.it
http://www.smcitalia.it



Russia

SMC Pneumatik LLC.
36/40 Sredny pr. St. Petersburg 199004
Phone: +812 118 5445, Fax: +812 118 5449
E-mail: smcfa@peterlink.ru
http://www.smc-pneumatik.ru



Estonia

SMC Pneumatics Estonia OÜ
Laki 12-101, 106 21 Tallinn
Phone: +372 (0)6 593540, Fax: +372 (0)6 593541
E-mail: smc@smcpneumatics.ee
http://www.smcpneumatics.ee



Latvia

SMC Pneumatics Latvia SIA
Smerla 1-705, Riga LV-1006, Latvia
Phone: +371 (0)777-94-74, Fax: +371 (0)777-94-75
E-mail: info@smclv.lv
http://www.smclv.lv



Slovakia

SMC Priemysel'na Automatizácia, s.r.o.
Námestie Martina Benku 10, SK-81107 Bratislava
Phone: +421 2 444 56725, Fax: +421 2 444 56028
E-mail: office@smc.sk
http://www.smc.sk



Finland

SMC Pneumatics Finland OY
PL72, Tiistinniityntie 4, SF-02031 ESPOO
Phone: +358 (0)9-859 580, Fax: +358 (0)9-8595 8595
E-mail: smcfi@smc.fi
http://www.smc.fi



Lithuania

UAB Ottensten Lietuva
Savanoriu pr. 180, LT-2600 Vilnius, Lithuania
Phone/Fax: +370-2651602



Slovenia

SMC industrijska Avtomatika d.o.o.
Grajski trg 15, SLO-8360 Zuzemberk
Phone: +386 738 85240 Fax: +386 738 85249
E-mail: office@smc-ind-avtom.si
http://www.smc-ind-avtom.si



OTHER SUBSIDIARIES WORLDWIDE:

ARGENTINA, AUSTRALIA, BOLIVIA, BRASIL, CANADA, CHILE,
CHINA, HONG KONG, INDIA, INDONESIA, MALAYSIA, MEXICO,
NEW ZEALAND, PHILIPPINES, SINGAPORE, SOUTH KOREA,
TAIWAN, THAILAND, USA, VENEZUELA

<http://www.smceu.com>
<http://www.smcworld.com>