

Magnetically Coupled Rodless Cylinder  
Low Profile Guide Type

# Series *CY1F*

Size:  $\varnothing 10$ ,  $\varnothing 15$ ,  $\varnothing 25$

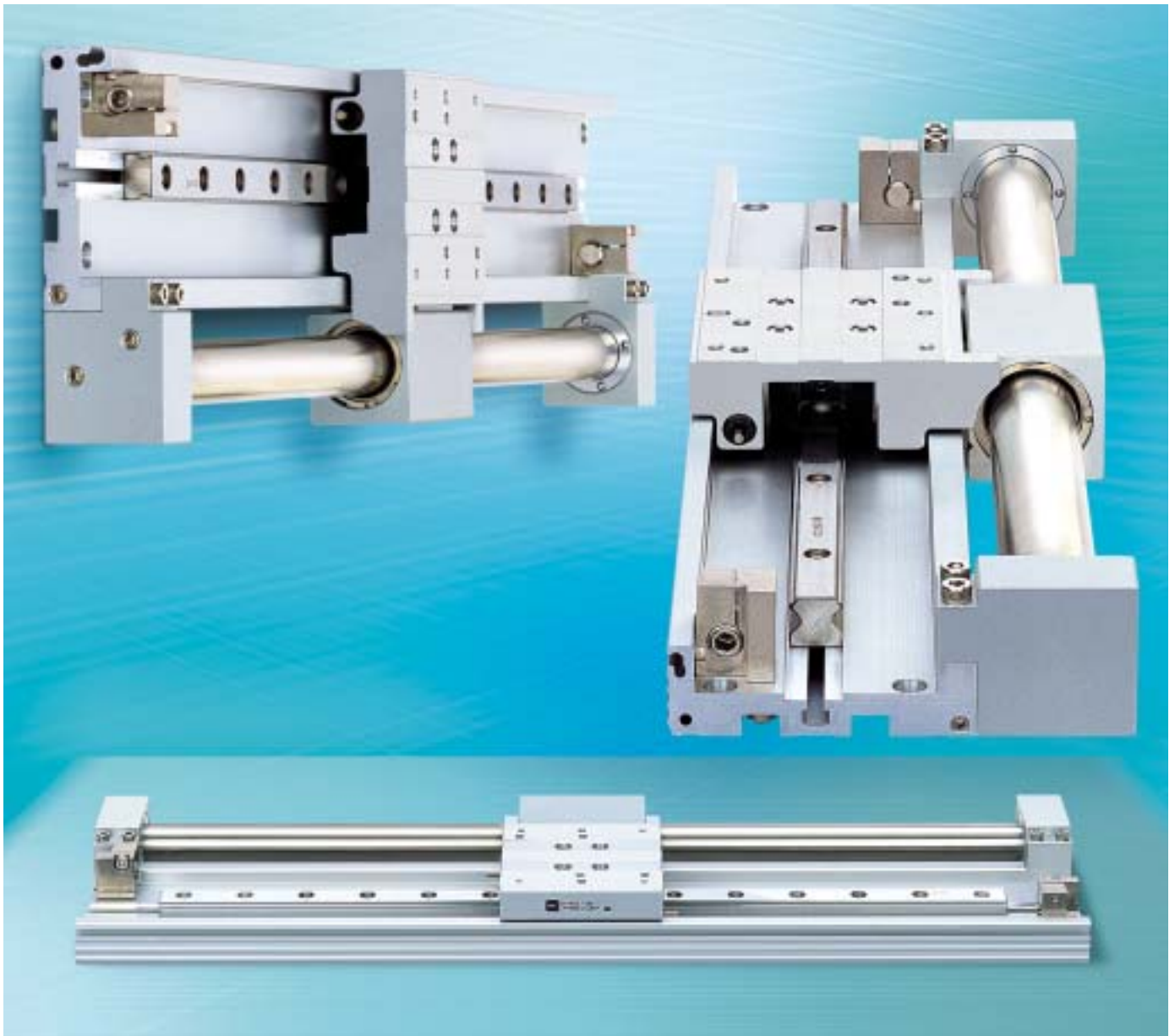

New Series of magnetically coupled rodless cylinder featuring compact and low profile design.

# New Series of magnetically coupled rodless

## With reduced mounting height and overall length,

Low profile

Height reduced by 29%

Compact body

Overall length reduced by 31%

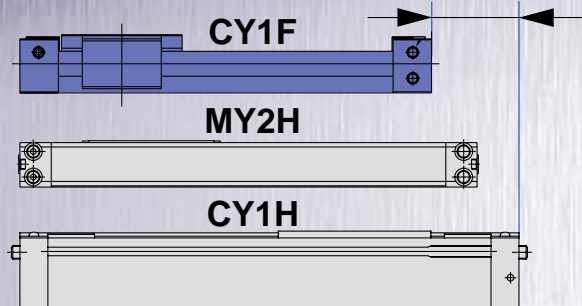
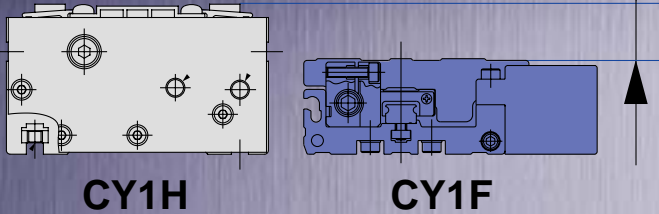

Height			
Series	ø10	ø15	ø25
CY1F	28	34	46
CY1H	39.5	46	63

Overall length			
Series	ø10	ø15	ø25
CY1F	198	205	240
CY1H	225	294	350
MY2H	—	260	310

\*For 100mm stroke cylinder

Overall length reduced by 22% compared to Series MY2H

Magnetically coupled rodless cylinder: Low profile guide

Series **CY1F**: ø10, ø15, ø25

Various concentrated piping ports are available.

Piping port position can be specified using a part number.  
3 types of piping screws are available.

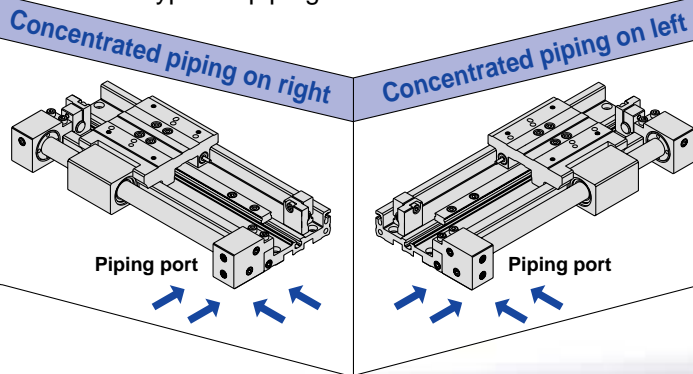

4 types of stroke adjustment are available.

	Left adjustment bolt	Right adjustment bolt
Both sides standard type	-1mm to 0mm	-1mm to 0mm
AL type	-25mm to 0mm	-1mm to 0mm
AR type	-1mm to 0mm	-25mm to 0mm
A type	-25mm to 0mm	-25mm to 0mm



# cylinder featuring compact and low profile design. small work pieces can be transferred with high precision.

Lightweight

Weight reduced by 50%

Series	ø10	ø15	ø25	kg
CY1F	0.7	1.1	2.5	
CY1H	1.0	2.2	4.6	
MY2H	—	1.3	3.2	

\*For 100mm stroke cylinder

Available bore sizes ø10, 15, 25

Model	Bore size (mm)	Standard stroke (mm)											Maximum stroke	Cushion	Piping directions		
		50	100	150	200	250	300	350	400	450	500	550				600	
CY1F	10	●	●	●	●	●	●	●	●	●	●	●	●	●	500	Built-in shock absorber	Concentrated piping on right
	15	●	●	●	●	●	●	●	●	●	●	●	●	●	750		Concentrated piping on left
	25	●	●	●	●	●	●	●	●	●	●	●	●	●	1200		

Accumulated dust on the guide can be removed easily without an end cover.



The cylinder and guide are integrated.

The cylinder portion can be replaced without interfering with the work piece.

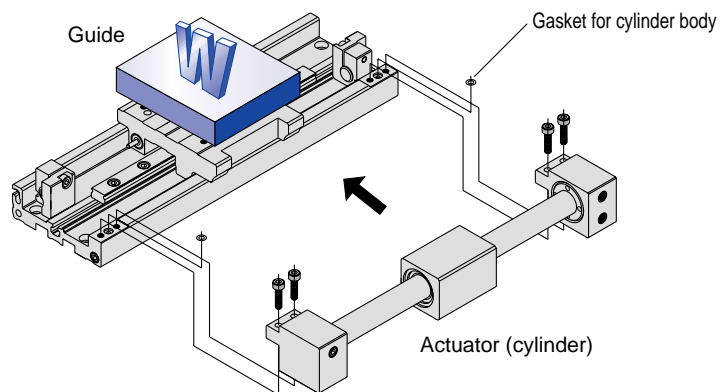

# Series CY1F Model Selection 1

The following are the steps for selection of the series CY1F best suited to your application.

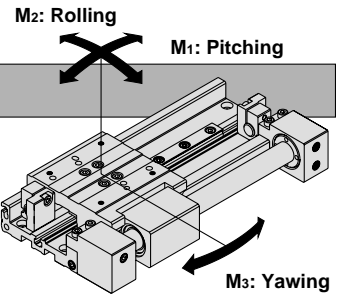

## Standards for Tentative Model Selection

Cylinder model	Guide model	Standard for guide selection	Graph for related allowable values
CY1F	High precision guide (Single axis)	Slide table accuracy approx. ±0.05mm or less	Refer to page 4

## Selection Flow Chart

**Es:** Allowable kinetic energy for intermediate stop by pneumatic circuit (J)  
**Ps:** Operating pressure limit for intermediate stop by external stopper, etc. Limit value(MPa)  
**Pv:** Maximum operating pressure in vertical operation (MPa)  
**mv:** Maximum allowable load mass in vertical operation (kg)  
**α:** Load factor  

$$\Sigma\alpha = \frac{\text{Load mass (m)}}{\text{Maximum allowable load (m}_{\text{max}})} + \frac{\text{Static moment (M)}}{\text{Allowable static moment (M}_{\text{max}})} + \frac{\text{Dynamic moment (ME)}}{\text{Allowable dynamic moment (ME}_{\text{max}})}$$
  
**E:** Load kinetic energy (J)  

$$E = \frac{m}{2} \left( \frac{Ua}{1000} \right)^2$$

### Operating conditions

- m: Load mass (kg)
- Pv: Operating pressure (MPa)
- L: Centre of gravity of the work piece (mm)
- Mode of operation (Horizontal, Inclination, Vertical)
- Ua: Average speed

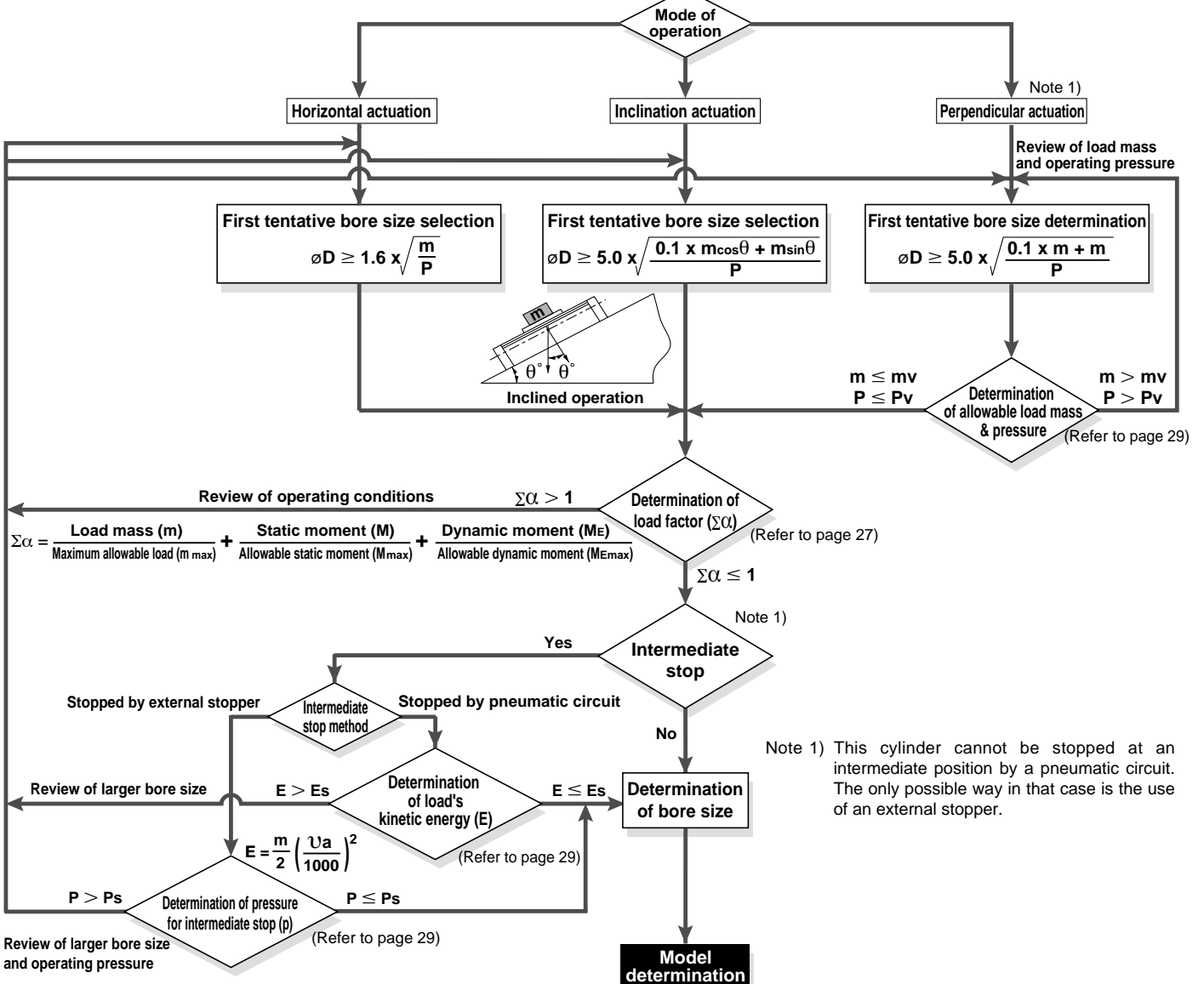

## Types of Moment Applied to Rodless Cylinders

Multiple moments may be generated depending on the mounting orientation load and position of the center of gravity.

### Coordinates and Moments

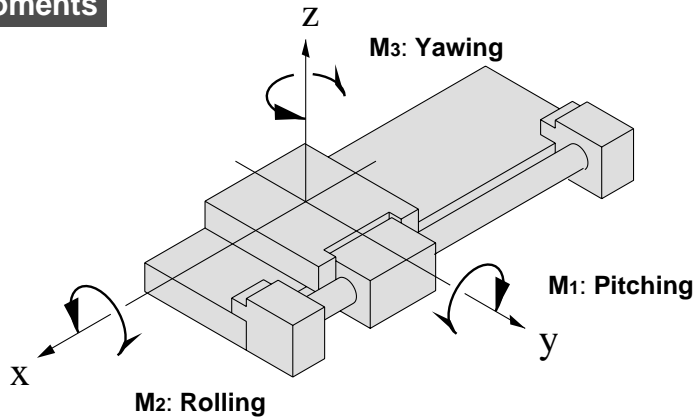

### Static moment

Horizontal mounting

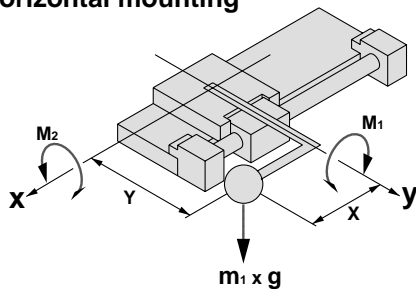

Ceiling mounting

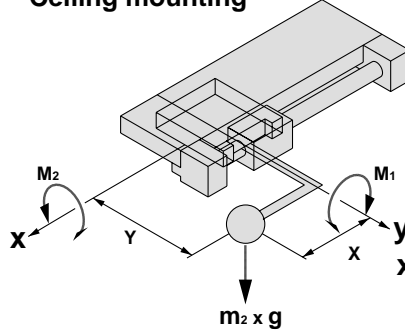

Wall mounting

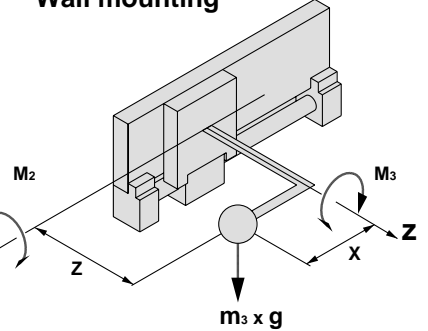

Vertical mounting

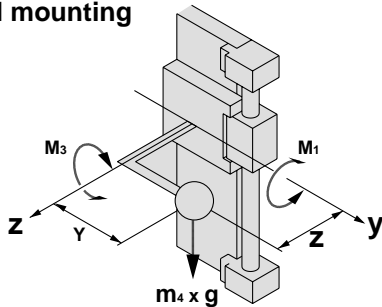

g: Gravitational acceleration

Mounting orientation	Horizontal	Ceiling	Wall	Vertical
Static load m	$m_1$	$m_2$	$m_3$	$m_4$
Static moment				
$M_1$	$m_1 \times g \times X$	$m_2 \times g \times X$	—	$m_4 \times g \times Z$
$M_2$	$m_1 \times g \times Y$	$m_2 \times g \times Y$	$m_3 \times g \times Z$	—
$M_3$	—	—	$m_3 \times g \times X$	$m_4 \times g \times Y$

### Dynamic moment

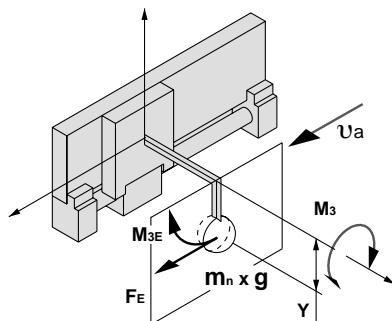
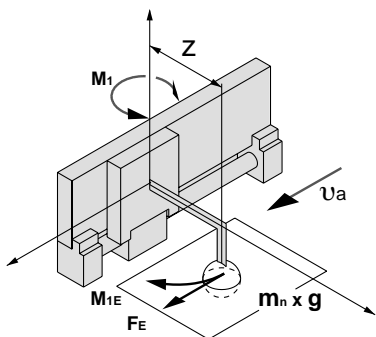

g: Gravitational acceleration, Ua: Average speed

Mounting orientation	Horizontal	Ceiling	Wall	Vertical
Dynamic load $F_E$	$\frac{1.4}{100} \times U_a \times m_n \times g$			
Dynamic moment				
$M_{1E}$	$\frac{1}{3} \times F_E \times Z$			
$M_{2E}$	Dynamic moment $M_{2E}$ is not generated.			
$M_{3E}$	$\frac{1}{3} \times F_E \times Y$			

Note) Regardless of the mounting orientation, dynamic moment is calculated with the formulas above.

## Maximum Allowable Moment/Maximum Allowable Load

Model	Bore size (mm)	Maximum allowable moment (N·m)			Maximum allowable load (kg)			
		M <sub>1</sub>	M <sub>2</sub>	M <sub>3</sub>	m <sub>1</sub>	m <sub>2</sub>	m <sub>3</sub>	m <sub>4</sub>
CY1F	10	1	2	1	2	2	2	1.4
	15	1.5	3	1.5	5	5	5	2
	25	14	20	14	12	12	12	12

The above values are the maximum allowable values for moment and load. Refer to each graph regarding the maximum allowable moment and maximum allowable load for a particular piston speed.

### Maximum allowable moment

Select the moment from within the range of operating limits shown in the graphs. Note that the maximum allowable load value may sometimes be exceeded even within the operating limits shown in the graphs. Therefore, also check the allowable load for the selected conditions.

### Load (kg)

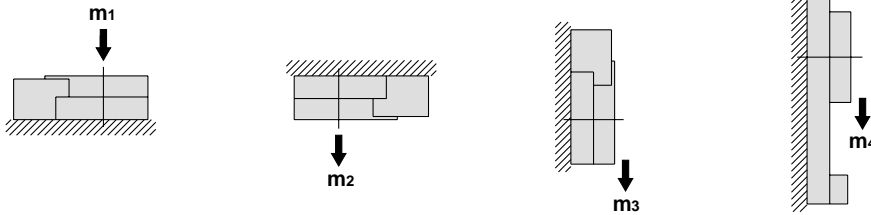

### Moment (N·m)

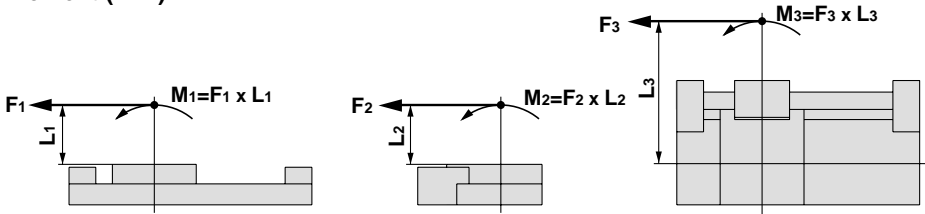

### <Calculation guide load factor>

1. Maximum allowable load (1), static moment (2), and dynamic moment (3) (at the time of impact with stopper) must be examined for the selection calculations.

\* To evaluate, use  $U_a$  (average speed) for (1) and (2), and  $U$  (impact speed  $U = 1.4U_a$ ) for (3). Calculate  $m_{max}$  for (1) from the maximum allowable load graph ( $m_1, m_2, m_3$ ) and  $M_{max}$  for (2) and (3) from the maximum allowable moment graph ( $M_1, M_2, M_3$ ).

$$\text{Sum of guide load factors } \Sigma\alpha = \frac{\text{Load mass [m]}}{\text{Maximum allowable load [m}_{max}\text{]}} + \frac{\text{Static moment [M]}^{\text{Note 1)}}}{\text{Allowable static moment [M}_{max}\text{]}} + \frac{\text{Dynamic moment [ME]}^{\text{Note 2)}}}{\text{Allowable dynamic moment [ME}_{max}\text{]}} \leq 1$$

Note 1) Moment caused by the load, etc., with cylinder in resting condition.  
 Note 2) Moment caused by the impact load equivalent at the stroke end (at the time of impact with stopper).  
 Note 3) Depending on the shape of the work piece, multiple moments may occur. When this happens, the sum of the load factors ( $\Sigma\alpha$ ) is the total of all such moments.

### 2. Reference formulas [Dynamic moment at impact]

Use the following formulas to calculate dynamic moment when taking stopper impact into consideration.

- m : Load mass (kg)
- F : Load (N)
- F<sub>E</sub> : Load equivalent to impact (at impact with stopper) (N)
- U<sub>a</sub> : Average speed (mm/s)
- M : Static moment (N·m)
- U : Impact speed (mm/s)
- L<sub>1</sub> : Distance to the load's center of gravity (m)
- M<sub>E</sub> : Dynamic moment (N·m)
- g : Gravitational acceleration (9.8m/s<sup>2</sup>)

$$U = 1.4U_a \text{ (mm/s)} \quad F_E = \frac{1.4}{100} U_a \cdot g \cdot m \text{ Note 4)}$$

$$\therefore M_E = \frac{1}{3} \cdot F_E \cdot L_1 = 0.05U_a m L_1 \text{ (N·m) Note 5)}$$

Note 4)  $\frac{1.4}{100} U_a$  is a dimensionless coefficient for calculating impact force.

Note 5) Average load coefficient ( $= \frac{1}{3}$ ):  
 This coefficient is for averaging the maximum load moment at the time of stopper impact according to service life calculations.

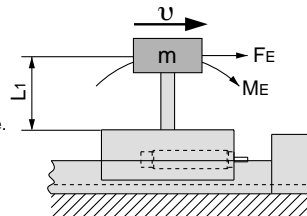

### Maximum allowable load

Select the load from within the range of limits shown in the graphs. Note that the maximum allowable moment value may sometimes be exceeded even within the operating limits shown in the graphs. Therefore, also check the allowable moment for the selected conditions.

3. Refer to page 30 and 31 for detailed selection procedures.

**1** CY1F/M<sub>1</sub>

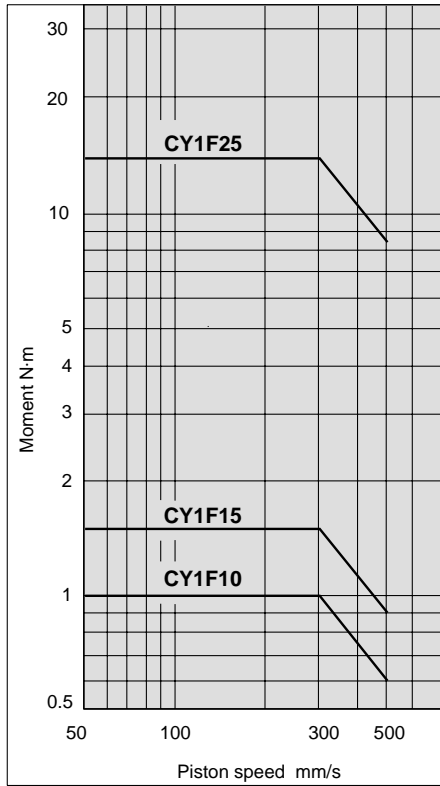

**2** CY1F/M<sub>2</sub>

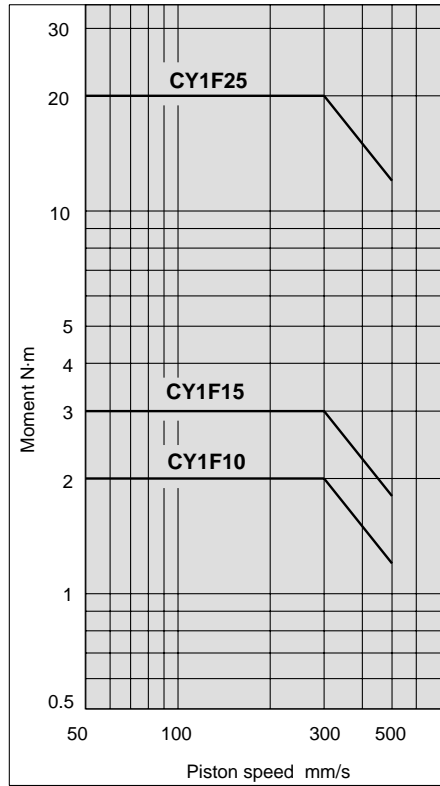

**3** CY1F/M<sub>3</sub>

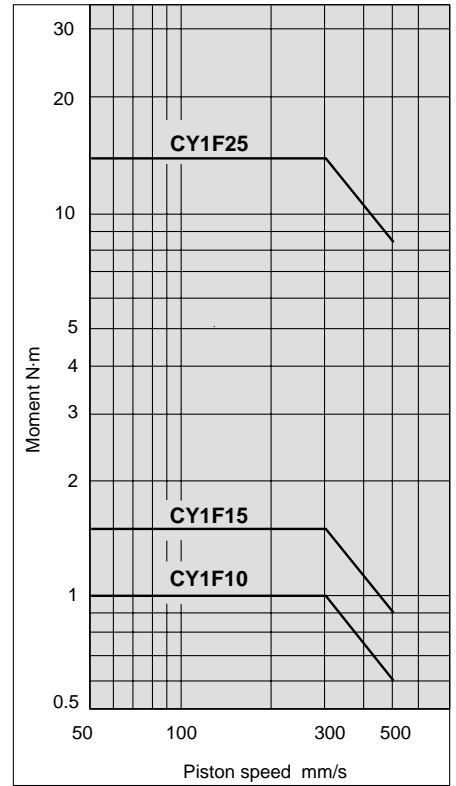

**4** CY1F/m<sub>1</sub>

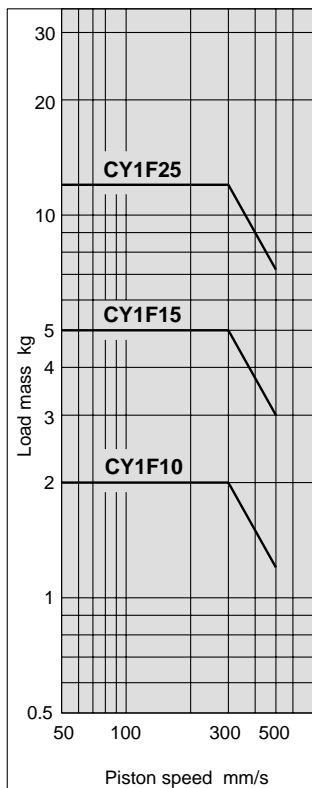

**5** CY1F/m<sub>2</sub>

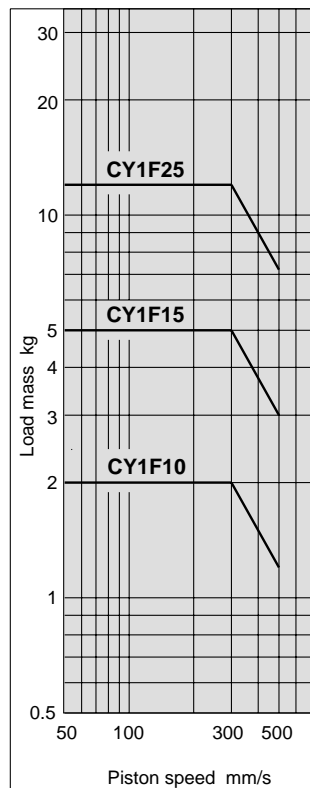

**6** CY1F/m<sub>3</sub>

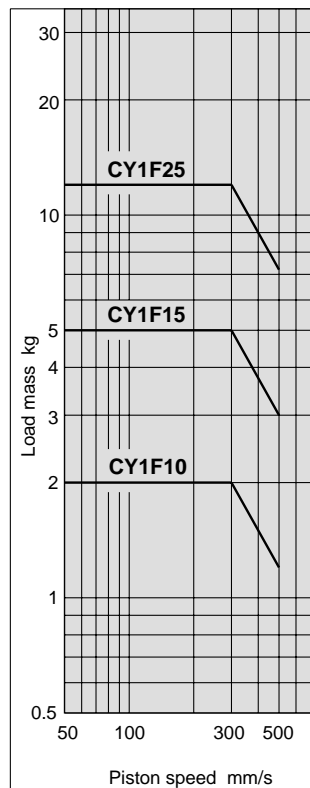

**7** CY1F/m<sub>4</sub>

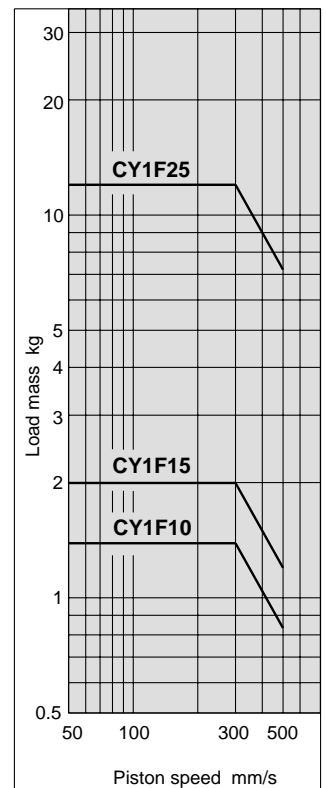

## Vertical Actuation

### ① Vertical operation

In vertical operation, observe the maximum load mass and the maximum operating pressure shown in the table below to prevent a drop due to slipping off of magnet couplings.

### Caution

If the maximum load mass or maximum operating pressure is exceeded, it will cause the magnet coupling to slip off.

Bore size (mm)	Maximum load weight mv (kg)	Maximum operating pressure Pv (MPa)
10	1.4	0.55
15	2.0	0.65
25	12	0.65

## Intermediate Stop

### ① Intermediate stop by external stopper or stroke adjustment with adjustment bolt.

Observe the maximum pressure limit in the table below in case of intermediate stop by an external stopper or stroke adjustment with the attached adjustment bolt.

### Caution

Be careful if the operating pressure limit is exceeded, it will cause the magnet coupling to slip off.

Bore size (mm)	Holding force (N)	Operating pressure limit for intermediate stop Ps (MPa)
10	53.9	0.55
15	137	0.65
25	363	0.65

### ② The load is stopped by pneumatic circuit.

Observe the maximum kinetic energy in the table below in case the load is stopped at an intermediate position by a pneumatic circuit. Note that intermediate stop by a pneumatic circuit is not available in vertical operation.

### Caution

If the allowable kinetic energy is exceeded, it will cause the magnet coupling to slip off.

Bore size (mm)	Allowable kinetic energy for intermediate stop Es (J)
10	0.03
15	0.13
25	0.45



# Series CY1F Model Selection 2

## Selection Calculation

The selection calculation finds the load factors ( $\Sigma\alpha_n$ ) of the items below, where the total ( $\alpha_n$ ) does not exceed 1.

$$\Sigma\alpha_n = \alpha_1 + \alpha_2 + \alpha_3 \leq 1$$

Item	Load factor $\alpha_n$	Note
1 Maximum load mass	$\alpha_1 = m/m_{\max}$	Review $m$ $m_{\max}$ is the maximum load mass at $v_a$
2 Static moment	$\alpha_2 = M/M_{\max}$	Review $M_1, M_2, M_3$ $M_{\max}$ is the allowable moment at $v_a$
3 Dynamic moment	$\alpha_3 = M_E/M_{E\max}$	Review $M_{1E}, M_{2E}, M_{3E}$ $M_{E\max}$ is the allowable moment at $v_a$

$v$ : Collision speed  $v_a$ : Average speed

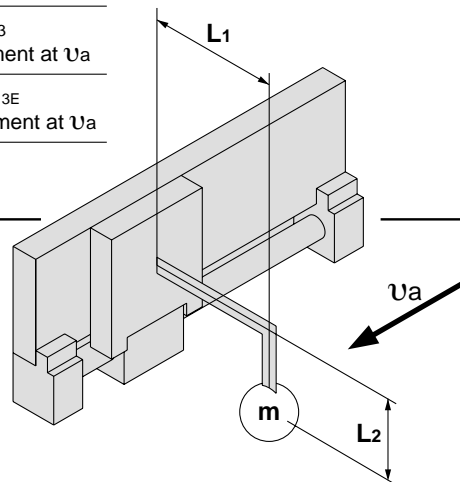

### Calculation example 1

#### Operating conditions

Cylinder: CY1F15  
Terminal buffer mechanism: Standard (shock absorber)  
Mounting: Wall mounting  
Speed (average) :  $v_a = 300$  [mm/s]  
Load mass:  $m = 0.5$  [kg] (excluding weight of arm section)  
 $L_1 = 50$  [mm]  
 $L_2 = 40$  [mm]

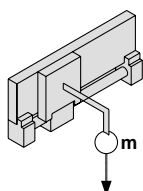
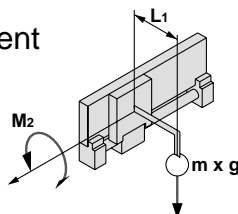
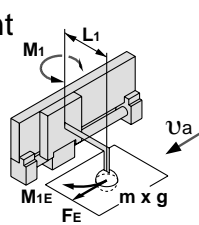
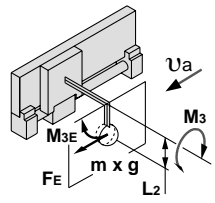
Item	Load factor $\alpha_n$	Note
1 Load mass 	$\alpha_1 = m/m_{\max}$ $= 0.5/5$ $= 0.1$	Investigate $m$ . Find the value of $m_{\max}$ at 300mm/s in Graph 6 for $m_3$ on page 28.
2 Static moment 	$M_2 = m \times g \times L_1$ $= 0.5 \times 9.8 \times 0.05$ $= 0.245$ [N·m] $\alpha_2 = M_2/M_{2\max}$ $= 0.245/3$ $= 0.082$	Investigate $M_2$ . $M_1$ and $M_3$ are not required because they are not generated. Find the value of $M_2_{\max}$ at 300mm/s in Graph 2.
3 Dynamic moment  	$M_{1E} = 1/3 \times F_E \times L_1$ ( $F_E = 1.4/100 \times v_a \times g \times m$ ) $= 0.05 \times v_a \times m \times L_1$ $= 0.05 \times 300 \times 0.5 \times 0.05$ $= 0.375$ [N·m] $\alpha_{3A} = M_{1E}/M_{1E\max}$ $= 0.375/1.07$ $= 0.350$ $M_{3E} = 1/3 \times F_E \times L_2$ ( $F_E = 1.4/100 \times v_a \times g \times m$ ) $= 0.05 \times v_a \times m \times L_2$ $= 0.05 \times 300 \times 0.5 \times 0.04$ $= 0.3$ [N·m] $\alpha_{3B} = M_{3E}/M_{3E\max}$ $= 0.3/1.07$ $= 0.28$	Investigate $M_{1E}$ . Find the collision speed $v$ . $v = 1.4 \times v_a$ $= 1.4 \times 300$ $= 420$ [mm/s] Find the value of $M_{E1\max}$ at 420mm/s in Graph 1. Investigate $M_{3E}$ . From above, find the value of $M_{3E\max}$ at 420mm/s in Graph 3.

From above,

$$\Sigma\alpha_n = \alpha_1 + \alpha_2 + \alpha_{3A} + \alpha_{3B} = 0.1 + 0.082 + 0.35 + 0.28 = 0.812.$$

From  $\Sigma\alpha_n = 0.812 \leq 1$ , it is applicable.

# Series CY1F Model Selection 3

## Calculation example 2

### Operating conditions

Cylinder: CY1F25  
Terminal buffer mechanism: Standard (shock absorber)  
Mounting: Vertical mounting  
Speed (average) :  $U_a=300$  [mm/s]  
Load mass:  $m = 3$  [kg] (excluding weight of arm section)  
 $L_1 = 50$  [mm]  
 $L_2 = 40$  [mm]

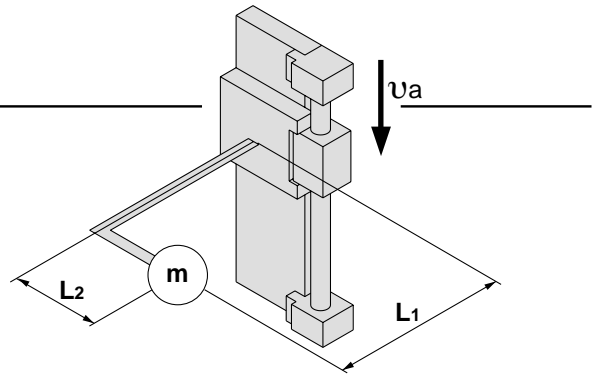

Item	Load factor $\alpha_n$	Note
<b>1</b> Load mass 	$\alpha_1 = m/m_{\max}$ $= 3/12$ $= \mathbf{0.25}$	Investigate $m$ . Find the value of $m_{\max}$ at 300mm/s in Graph 7 for $m_3$ .
<b>2</b> Static moment 	$M_1 = m \times g \times L_1$ $= 3 \times 9.8 \times 0.05$ $= 1.47$ [N·m] $\alpha_{2a} = M_1/M_{1\max}$ $= 1.47/14$ $= \mathbf{0.105}$  $M_3 = m \times g \times L_2$ $= 3 \times 9.8 \times 0.04$ $= 1.176$ [N·m] $\alpha_{2b} = M_3/M_{3\max}$ $= 1.176/14$ $= \mathbf{0.084}$	Investigate $M_1$ . Find the value of $M_{2\max}$ at 300mm/s in Graph 1.  Investigate $M_3$ . Find the value of $M_{3\max}$ at 300mm/s in Graph 3.
<b>3</b> Dynamic moment 	$M_{1E} = 1/3 \times F_E \times L_1$ $(F_E = 1.4/100 \times U_{ax} \times g \times m)$ $= 0.05 \times U_{ax} \times m \times L_1$ $= 0.05 \times 300 \times 3 \times 0.05$ $= 2.25$ [N·m] $\alpha_{3A} = M_{1E}/M_{1E\max}$ $= 2.25/10$ $= \mathbf{0.225}$  $M_{3E} = 0.05 \times U_{ax} \times m \times L_2$ $(F_E = 1.4/100 \times U_{ax} \times g \times m)$ $= 0.05 \times 300 \times 3 \times 0.04$ $= 1.8$ [N·m] $\alpha_{3B} = M_{3E}/M_{3E\max}$ $= 1.8/10$ $= \mathbf{0.18}$	Investigate $M_{1E}$ . Find the collision speed $U$ $U = 1.4 \times U_a$ $= 1.4 \times 300$ $= 420$ [mm/s] Find the value of $M_{1E\max}$ at 420mm/s in Graph 1.  Investigate $M_{3E}$ . From above, find the value of $M_{3E\max}$ at 420mm/s in Graph 3.

From above,

$$\Sigma \alpha_n = \alpha_1 + \alpha_{2a} + \alpha_{2b} + \alpha_{3A} + \alpha_{3B} = 0.25 + 0.105 + 0.084 + 0.225 + 0.18 = 0.844$$

From  $\Sigma \alpha_n = 0.844 \leq 1$ , it is applicable.



# Magnetically Coupled Rodless Cylinder

# Series CY1F

Low Profile Guide Type/ø10, ø15, ø25

## How to order

**CY1F** **10** **R** **300** **F9BW**

• Bore size (mm)

10	10
15	15
25	25

• Piping thread type

Symbol	Type	Bore size (mm)
Nil	M	10, 15
	Rc	
TN	NPT	25
TF	G	

• Number of auto switches

Nil	2 pcs.
S	1 pc.
n	"n" pcs.

• Auto switch

Nil	Without auto switch
-----	---------------------

\*Refer to the table below for auto switch model numbers.

• Adjustment bolt suffix

Nil	Both sides are standard
AL	Right: Standard For 25 mm adjustment on left
AR	For 25 mm adjustment on right Left: Standard
A	For 25 mm adjustment on both sides

• Piping direction

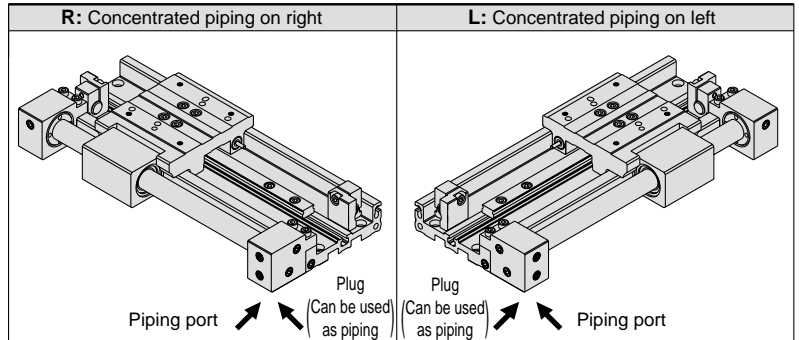

**Applicable auto switches/** Refer to pages 14 through 19 for detailed auto switch specifications.

Type	Special function	Electrical entry	Indicator light	Wiring (output)	Load voltage			Auto switch models		Lead wire length (m)*			Applicable load	
					DC	AC		Electrical entry direction		0.5 (Nil)	3 (L)	5 (Z)		
						24V	5V 12V	100V or less	Perpendicular				In-line	
Reed switch	—	Grommet	No	2-wire	24V	5V 12V	100V	A90V	A90	●	●	—	IC circuit	Relay PLC
								A93V	A93	●	●	—	—	
Solid state switch	—	Grommet	Yes	3-wire (NPN equiv.)	24V	5V 12V	—	F9NV	F9N	●	●	○	IC circuit	Relay PLC
								F9PV	F9P	●	●	○	—	
				2-wire	24V	12V	—	F9BV	F9B	●	●	○	—	
								F9N WV	F9N W	●	●	○	IC circuit	
				3-wire (NPN)	5V 12V	—	—	F9PWV	F9P W	●	●	○	—	
								F9B WV	F9B W	●	●	○	—	

\*Lead wire length symbols 0.5m ..... Nil (Example) F9NW  
3m ..... L F9NWL  
5m ..... Z F9N WZ

\*Solid state switches marked with a "○" symbol are produced upon receipt of order.

## Specifications



Bore size (mm)	10	15	25
Fluid	Air		
Lubrication	Non-lube		
Actuation	Double acting		
Maximum operating pressure (MPa)	0.7		
Minimum operating pressure (MPa)	0.2		
Proof pressure (MPa)	1.05		
Ambient and fluid temperature (°C)	-10 to 60		
Piston speed (mm/s)	50 to 500		
Cushion	Built-in shock absorber		
Stroke length tolerance (mm)	0 to 250st: $^{+1.0}_0$	251 to 1000st: $^{+1.4}_0$	1001st to: $^{+1.8}_0$
Stroke adjustment movable range (mm) <sup>Note 1)</sup>	-1.2 to 0.8		-1.4 to 0.6
Piping type	Centralized piping		
Port size <sup>Note 2)</sup>	M5		1/8

Note 1) The stroke adjustment movable range in the above table is that for the standard adjustment bolt.  
For more information, please refer to page 31.

Note 2) With ø25, piping screws can be selected by the customer. (Refer to How to Order.)

## Shock Absorber Specifications

Applicable bore size (mm)	10, 15	25	
Shock absorber model	RB0805- X552	RB1006- X552	
Max. energy absorption (J)	0.98	3.92	
Stroke absorption (mm)	5	6	
Max. impact speed (m/s) <sup>Note)</sup>	0.05 to 5		
Max. operating frequency (cycle/min)	80	70	
Spring force (N)	When expanded	1.96	4.22
	When compressed	3.83	6.18
Weight (g)	15	25	

Note) Represents the maximum absorption energy per cycle. Thus, the operation frequency can be increased with the absorption energy.

## Standard Stroke

Bore size (mm)	Standard stroke (mm)	Maximum stroke available (mm)
10	50, 100, 150, 200, 250, 300	500
15	50, 100, 150, 200, 250, 300, 350, 400, 450, 500	750
25	100, 150, 200, 250, 300, 350, 400, 450, 500, 550, 600	1200



\*The stroke is available in 1 mm increments with the maximum stroke as the upper limit. For a stroke in the standard stroke range, suffix the part number with-XB10. If the stroke does not fall within the standard stroke range, suffix the part No. with-XB11.  
Refer to the Made to Order Specifications on page 20.

## Magnetic Holding Force

Unit: N			
Bore size (mm)	10	15	25
Holding force	53.9	137	363



## Made to order Specifications

(Refer to page 20 regarding Made to Order Specifications for series CY1F)

# Series CY1F

## Theoretical Output

Unit: N

Bore size (mm)	Piston area (mm <sup>2</sup> )	Operating pressure [MPa]					
		0.2	0.3	0.4	0.5	0.6	0.7
10	78	15	23	31	39	46	54
15	176	35	52	70	88	105	123
25	490	98	147	196	245	294	343

Note) Theoretical output (N) = Pressure (MPa) x Piston area (mm<sup>2</sup>)

## Option

### Adjustment bolt

Bore size (mm)	Standard adjustment bolt	25 mm adjustment bolt
10, 15	CYF-S10	CYF-L10
25	CYF-S25	CYF-L25

## Weights

Unit: kg

Model	Basic weight	Additional weight per 50 mm stroke	Standard adjustment bolt weight	Weight of adjustment bolt for 25 mm adjustment
CY1F10	0.520	0.095	0.004	0.012
CY1F15	0.815	0.133	0.004	0.012
CY1F25	1.970	0.262	0.007	0.021

Calculation method example: CY1F15-150AL

Basic weight ..... 0.815kg      Cylinder stroke ..... 150st  
 Additional weight ..... 0.133kg/50st      Left ..... 25 mm adjustment bolt  
 Standard adjustment bolt weight ..... 0.004kg      Right ..... Standard adjustment bolt  
 Weight of adjustment bolt for 25 mm adjustment ..... 0.012kg  
 0.815 + 0.133 x 150 ÷ 50 + 0.004 + 0.012 = 1.23 (kg)

## Replacement Parts

### Part number of replacement shock absorber

Bore size (mm)	Shock absorber model no.
10, 15	RB0805- X552
25	RB1006- X552

Note) Order 2 units for each unit of cylinder.

## Replacement Actuator (Cylinder)

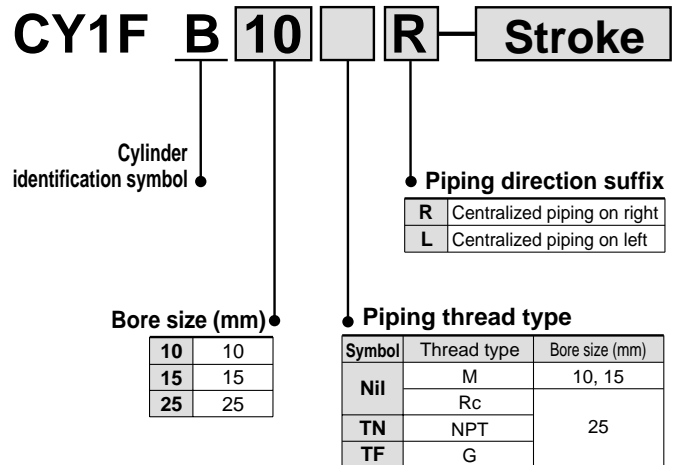

## Construction

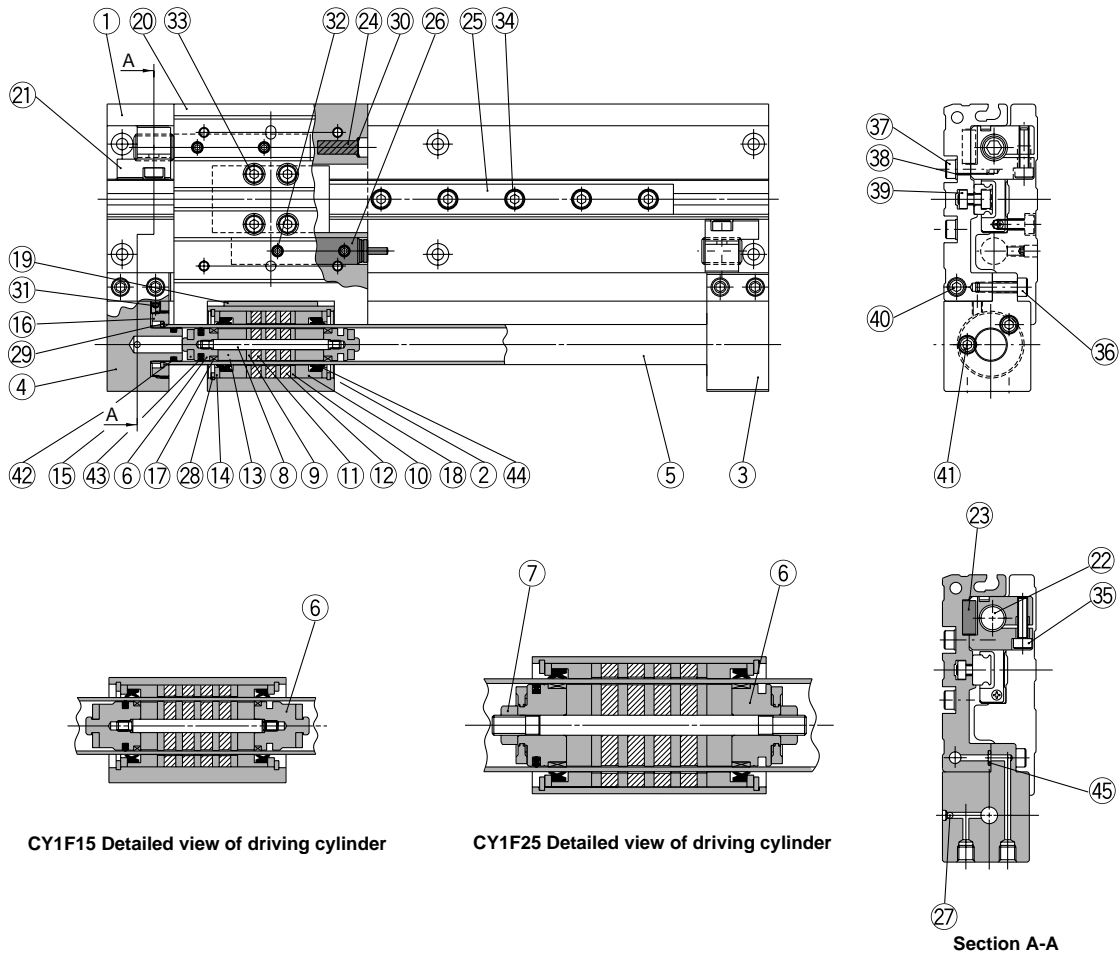

CY1F15 Detailed view of driving cylinder

CY1F25 Detailed view of driving cylinder

Section A-A

### Parts list

No.	Description	Material	Note
1	Body (rodless cylinder)	Aluminium alloy	Anodized
2	Body	Aluminium alloy	Hard anodized
3	End cover A	Aluminium alloy	Hard anodized
4	End cover B	Aluminium alloy	Hard anodized
5	Cylinder tube	Stainless steel	
6	Piston	Aluminium alloy	Chromate (ø25)
		Brass	Electroless nickel plated (ø10, ø15)
7	Piston nut	Carbon steel	(Only for ø25)
8	Shaft	Stainless steel	
9	Piston side yoke	Rolled steel plate	Zinc chromated (ø15, ø25) Zinc chromated (ø10)
10	External slider side yoke	Rolled steel plate	Zinc chromated (ø15, ø25) Zinc chromated (ø10)
11	Magnet A	Rare earth magnet	(ø15, ø25) (ø10)
12	Magnet B	Rare earth magnet	(ø15, ø25) Chromate (ø10)
13	Piston spacer	Aluminium alloy	
14	Spacer	Rolled steel plate	Nickel plated
15	Bumper	Urethane rubber	
16	Attachment ring	Aluminium alloy	Hard anodized
17	Wear ring A	Special resin	
18	Wear ring B	Special resin	
19	Wear ring C	Special resin	
20	Slide table	Aluminium alloy	Hard anodized
21	Adjuster holder	Carbon steel	Electroless nickel plated

### Parts list

No.	Description	Material	Note
22	Adjustment bolt	Chrome molybdenum steel	Nickel plated
23	Adjuster holder positioning key	Carbon steel	Zinc chromated
24	Magnet	Rare earth magnet	
25	Guide	—	
26	Shock absorber	—	
27	Steel ball	Bearing steel	
28	C type snap ring for hole	Carbon tool steel	Nickel plated
29	C type snap ring for shaft	Hard steel wire	(ø15)
		Stainless steel	(ø10, ø25)
30	Snap ring	Stainless steel	
31	Hexagon socket head set screw	Chrome molybdenum steel	Nickel plated
32	Hexagon socket head set screw	Chrome molybdenum steel	Nickel plated
33	Hexagon socket head bolt	Chrome molybdenum steel	Nickel plated
34	Hexagon socket head bolt	Chrome molybdenum steel	Nickel plated
35	Hexagon socket head bolt	Chrome molybdenum steel	Nickel plated
36	Hexagon socket head bolt	Chrome molybdenum steel	Nickel plated
37	Hexagon socket head bolt	Chrome molybdenum steel	Nickel plated
38	Flat washer	Rolled steel	Nickel plated
39	Square nut	Carbon steel	Nickel plated
40	Hexagon socket head plug	Chrome molybdenum steel	Nickel plated
41	Hexagon socket head plug	Chrome molybdenum steel	Nickel plated (Hexagon socket head taper plug for ø25)
42	Cylinder tube gasket	NBR	
43	Piston seal	NBR	
44	Scraper	NBR	
45	Body (rodless cylinder) gasket	NBR	

# Series CY1F

## Dimensions

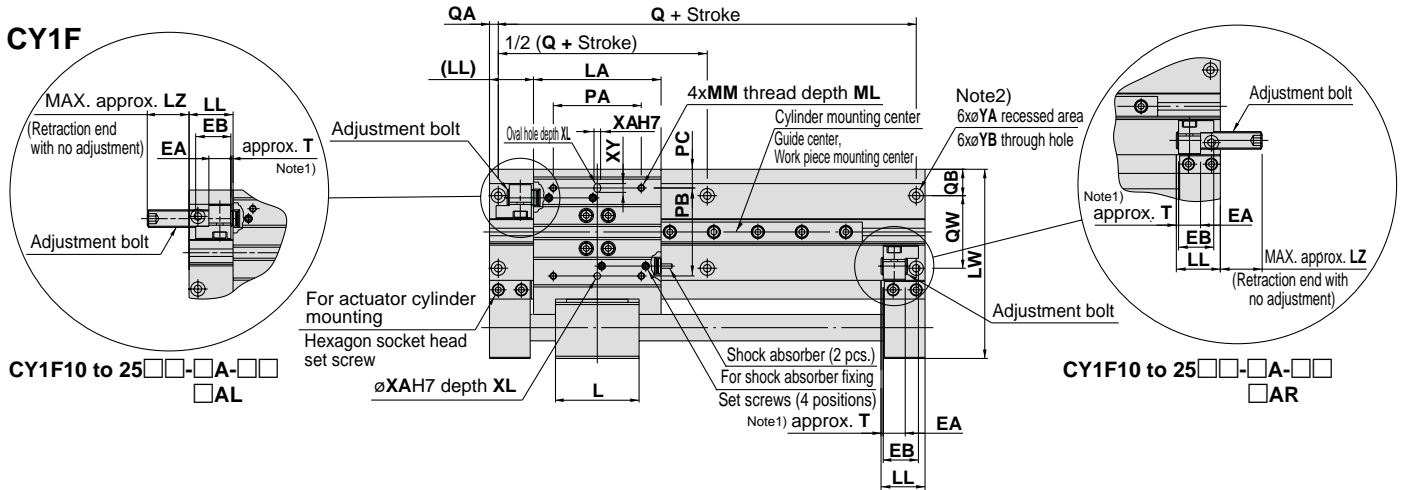

### Concentrated piping on right (CY1F10 to 25 R--)

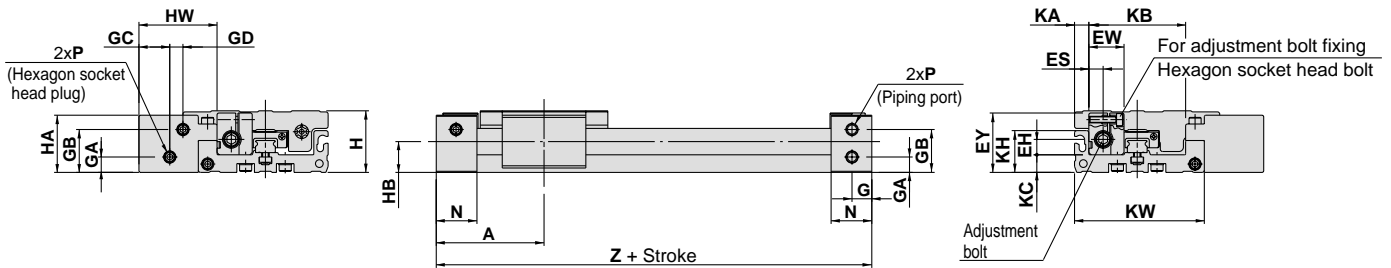

### Concentrated piping on left (CY1F10 to 25 L--)

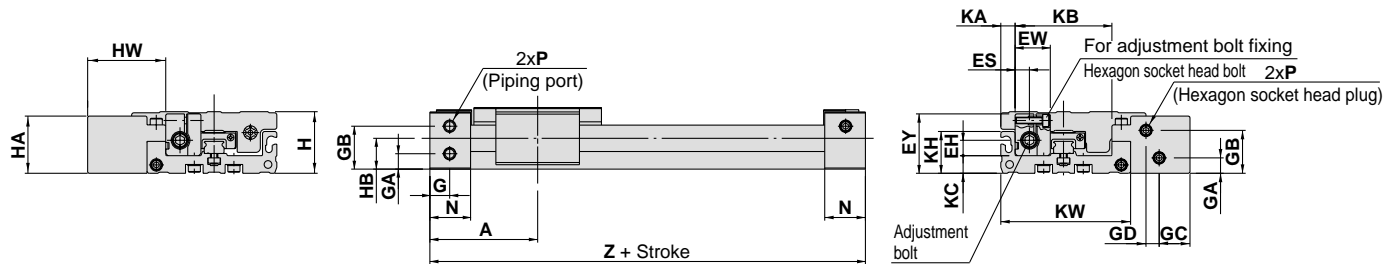

Model	Standard stroke	A	EA	EB	EH	ES	EW	EY	G	GA	GB	GC	GD	H	HA	HB	HW
CY1F10	50,100,150,200,250,300	49	10	16	7	6.5	16	27	9	7	19.5	14	6	28	26	14	35.5
CY1F15	50,100,150,200,250,300,350,400,450,500	52.5	10	16	7	6.5	16	29	9	8	23	17	9	34	32	17	41.5
CY1F25	50,100,150,200,250,300,350,400,450,500,550,600	70	13	17	10.5	8	22	40	10	12	33.5	22.5	12	46	44	23.5	55

Model	KA	KB	KC	KH	KW	L	LA	LL	LW	LZ	ML	MM	N	PA	PB	PC	Q	QA	QB	QW
CY1F10	6.5	44	8	19	59	38	58	20	86	19	5	M3	18.5	40	40	8.5	90	4	12	33
CY1F15	6.5	51	10	19	66	53	65	20	99	19	5	M3	18.5	50	50	7	97	4	12	40
CY1F25	7.5	66	13	27	84.5	70	89	25.5	128.5	17	9	M5	24	65	65	8	129	5.5	14.5	52

Model	T	XA	XL	XY	YA	YB	Z	Shock absorber
CY1F10	1	3 <sup>+0.012</sup> <sub>0</sub>	4	4	6.5 depth 3.4	3.4	98	RB0805- X552
CY1F15	1	3 <sup>+0.012</sup> <sub>0</sub>	4	4	6.5 depth 3.4	3.4	105	RB0805- X552
CY1F25	1	5 <sup>+0.012</sup> <sub>0</sub>	5	7.5	9.5 depth 5.4	5.5	140	RB1006- X552

Model	P (Piping port)		
	Nil	TN	TF
CY1F10	M5	—	—
CY1F15	M5	—	—
CY1F25	Rc1/8	NPT1/8	G1/8

Note 1) When adjusting the stroke, keep the T dimension within a 0 to 2 mm range. However, with the 25 mm adjustment bolt, an adjustment range of 0 to 26 mm is available.  
 Note 2) There are four øYA and øYB dimensions with a 50 mm stroke.



## Proper Mounting Position for Stroke End Detection

### D-A9□, D-A9□V (mm)

Bore size (mm)	Mounting pattern①		Mounting pattern②		Mounting pattern③		* Operating range
	A1	B1	A2	B2	A3	B3	
10	38	60	18	80	38	80	9
15	39	66	19	86	39	86	10
25	44.5	95.5	24.5	115.5	44.5	115.5	11

### D-F9□, D-F9□V (mm)

Bore size (mm)	Mounting pattern①		Mounting pattern②		Mounting pattern③		* Operating range
	A1	B1	A2	B2	A3	B3	
10	34	64	22	76	34	76	5.5
15	35	70	23	82	35	82	5
25	40.5	99.5	28.5	111.5	40.5	111.5	5

### D-F9□W, D-F9□WV (mm)

Bore size (mm)	Mounting pattern①		Mounting pattern②		Mounting pattern③		* Operating range
	A1	B1	A2	B2	A3	B3	
10	34	64	22	76	34	76	5.5
15	35	70	23	82	35	82	5
25	40.5	99.5	28.5	111.5	40.5	111.5	5

\*These values are given as a guideline including the hysteresis and are not guaranteed. They may vary significantly depending on the ambient environment (with ±30% variation).

Mounting pattern①

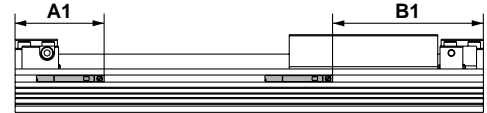

Mounting pattern②

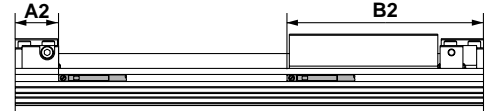

Mounting pattern③

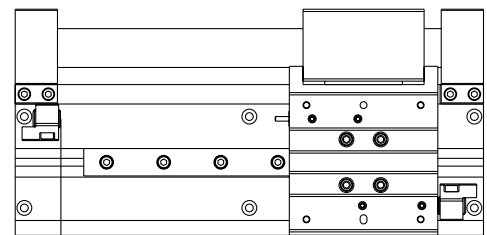
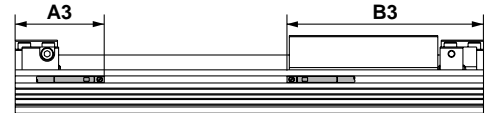

## ⚠ Caution

- ① When adjusting the stroke, confirm the minimum stroke for auto switch mounting.

See the table below for the minimum stroke for auto switch mounting.

### Minimum stroke for auto switch mounting (1pc.) (mm)

Bore size (mm)	D-A9□, D-A9□V D-F9□, D-F9□V	D-F9□W D-F9□WV
10	5	10
15		
25		

### Minimum stroke for auto switch mounting (2pcs.) (mm)

Bore size (mm)	D-A90 D-A96	D-A93	D-A90V D-A96V D-A93V	D-F9□ D-F9□W	D-F9□V D-F9□WV
Mounting pattern①, ②	32	35	22	32	20
Mounting pattern③	20			12	

## Auto Switch Mounting

As shown below, there are 3 ways to mount the auto switch according to 3 types of electrical entries. Insert the auto switch into the switch groove. Then use a flat head watchmaker's screw driver to tighten the included fixing screws.

Note) When tightening the holding screw (included with the auto switch), use a watchmaker's screw driver with a handle 5 to 6mm in diameter. The tightening torque should be 0.1 to 0.2N·m.

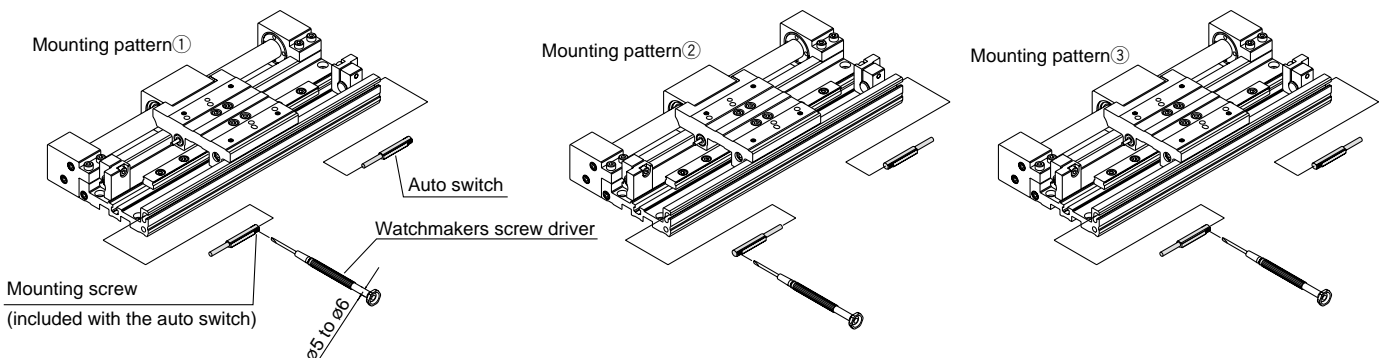

# Series CY1F Auto Switch Specifications

## Auto Switch Common Specifications

Type	Reed switch	Solid state switch
Leakage current	None	3wire: 100 $\mu$ A or less, 2-wire: 0.8mA or less
Operating time	1.2ms	1ms or less
Impact resistance	300m/s <sup>2</sup>	1000m/s <sup>2</sup>
Insulation resistance	50M $\Omega$ or more at 500VDC (between lead wire and case)	
Withstand voltage	1500VAC for 1min. (between lead wire and case)	1000VAC for 1min. (between lead wire and case)
Ambient temperature	-10 to 60°C	
Enclosure	IEC529 standard IP67, JISC0920 watertight construction	

## Lead Wire Length

Lead wire length indication

(Example) D-F9P **L**

Lead wire length

Nil	0.5m
L	3m
Z	5m

Note 1) Lead wire length Z: 5m applicable auto switches  
Solid state: All types are produced upon receipt of order  
(standard availability)

Note 2) For solid state switches with flexible lead wire specification, add  
"-61" at the end of the lead wire length.

(Example) D-F9PL- **61**

Flexible specification

## Contact Protection Boxes/CD-P11, CD-P12

<Applicable switches>

D-A9/A9□V

The above auto switches do not have internal contact protection circuits.

- ① The operating load is an induction load.
- ② The length of wiring to load is 5m or more.
- ③ The load voltage is 100 or 200 VAC.

Use a contact protection box in any of the above situations.

The life of the contacts may otherwise be reduced. (The may stay ON all the time.)

### Specifications

Part no	CD-P11		CD-P12
Load voltage	100VAC	200VAC	24VDC
Maximum load current	25mA	12.5mA	50mA

\*Lead wire length — Switch connection side 0.5m  
Load connection side 0.5m



### Internal circuits

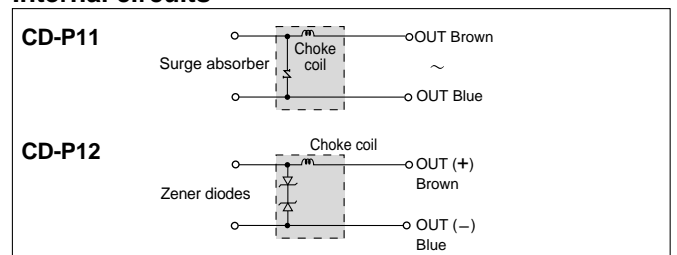

### Dimensions

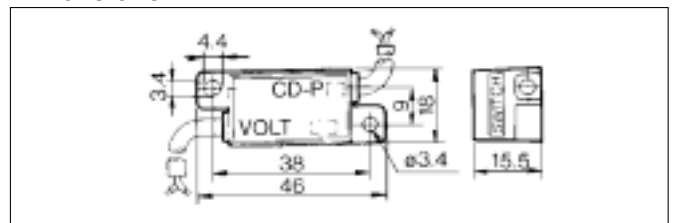

### Connection

To connect a switch to a contact protection box, connect the lead wire from the side of the contact protection box marked SWITCH to the lead wire coming out of the switch. Furthermore, the switch unit should be kept as close as possible to the contact protection box, with a lead wire length of no more than 1 meter between them.

# Series CY1F Auto Switch Connections and Examples

## Basic Wiring

### Solid state 3-wire, NPN

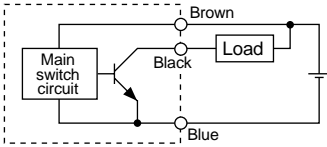

(Power supplies for switch and load are separate.)

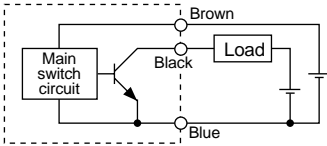

### Solid state 3-wire, PNP

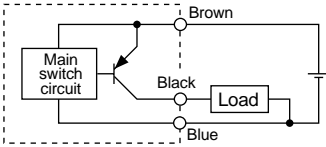

### 2-wire <Solid state>

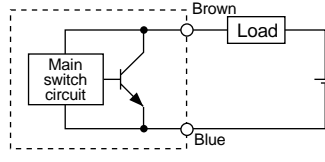

### 2-wire <Reed switch>

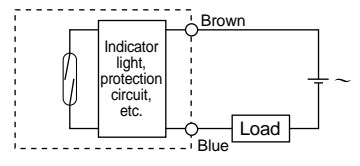
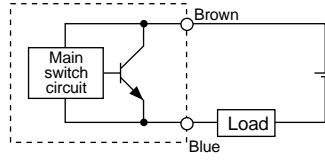
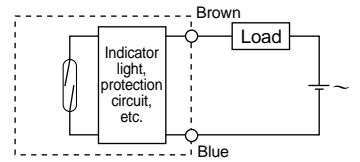

## Examples of Connection to PLC

### Sink input specifications

#### 3-wire, NPN

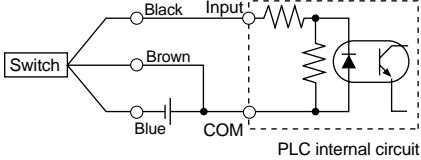

#### 2-wire

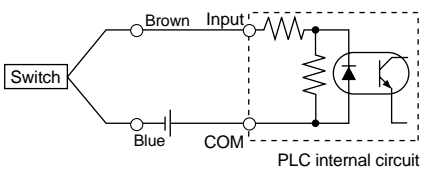

### Source input specifications

#### 3-wire, PNP

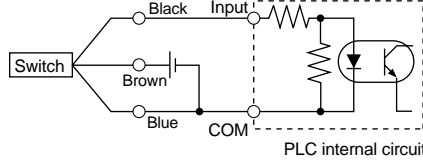

#### 2-wire

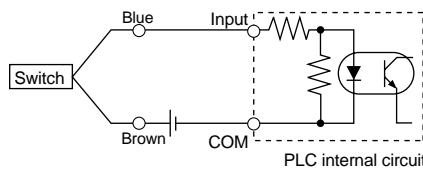

Connect according to the applicable PLC input specifications, as the connection method will vary depending on the PLC input specifications.

## Connection Examples for AND (Series) and OR (Parallel)

### 3-wire

#### AND connection for NPN output (Using relays)

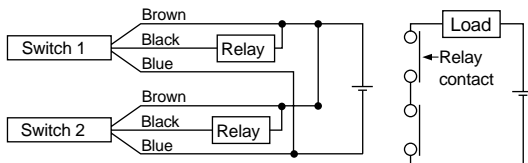

#### AND connection for NPN output (Performed with switches only)

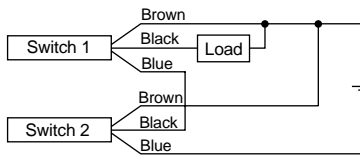

#### OR connection for NPN output

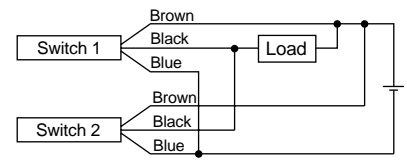

The indicator lights will light up when both switches are turned ON.

### 2-wire with 2 switch AND connection

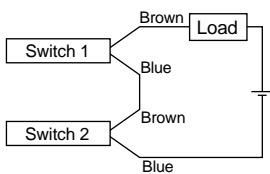

When two switches are connected in series, a load may malfunction because the load voltage will decline when in the ON state. The indicator lights will light up if both of the switches are in the ON state.

$$\begin{aligned} \text{Load voltage at ON} &= \text{Power supply voltage} - \text{Internal voltage drop} \times 2 \text{ pcs.} \\ &= 24\text{V} - 4\text{V} \times 2 \text{ pcs.} \\ &= 16\text{V} \end{aligned}$$

Example: Power supply is 24VDC  
Internal voltage drop in switch is 4V

### 2-wire with 2 switch OR connection

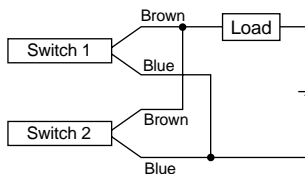

#### <Solid state>

When two switches are connected in parallel, malfunction may occur because the load voltage will increase when in the OFF state.

$$\begin{aligned} \text{Load voltage at OFF} &= \text{Leakage current} \times 2 \text{ pcs.} \times \text{Load impedance} \\ &= 1\text{mA} \times 2 \text{ pcs.} \times 3\text{k}\Omega \\ &= 6\text{V} \end{aligned}$$

Example: Load impedance is 3kΩ  
Leakage current from switch is 1mA

#### <Reed switch>

Because there is no current leakage, the load voltage will not increase when turned OFF. However, depending on the number of switches in the ON state, the indicator lights may sometimes dim or not light up, because of dispersion and reduction of the current flowing to the switches.

# Reed Switches/Direct Mount Type D-A90(V), D-A93(V), D-A96(V)

**Grommet**  
Electrical entry direction: Side

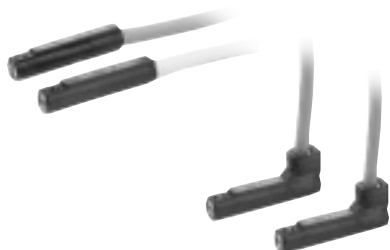

## Caution

### Precautions

- Be sure to use fixing screws attached to the auto switch to secure the switch. Use of screws out of the specifications can damage the switch.

## Auto Switch Internal Circuits

### D-A90V

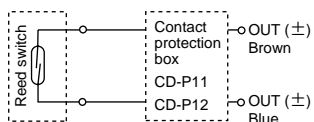

### D-A93V

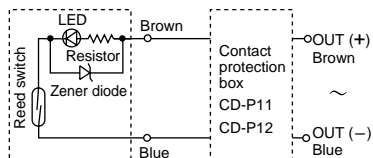

### D-A96V

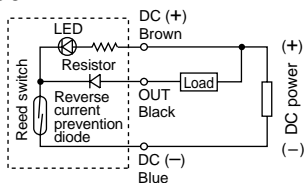

- Note) ①The operating load is inductive load.  
②The wiring to the load is 5 m or longer.  
③The load voltage is 100VAC.

If any of the above conditions is applicable, the life time of the contact may be shortened. Use a contact protection box. (Refer to page 15 about the contact protection box.)

## Auto Switch Specifications

D-A90, D-A90V (without indicator light)			
Auto switch part no.	D-A90, D-A90V		
Applicable load	IC circuit, Relay, PLC		
Load voltage	24V <sup>AC</sup> or less	48V <sup>AC</sup> or less	100V <sup>AC</sup> or less
Maximum load current	50mA	40mA	20mA
Contact protection circuit	None		
Internal resistance	1Ω or less (including 3m lead wire length)		
D-A93, D-A93V, D-A96, D-A96V (with indicator light)			
Auto switch part no.	D-A93, D-A93V		D-A96, D-A96V
Applicable load	Relay, PLC		IC circuit
Load voltage	24VDC	100VAC	4 to 8VDC
Load current range and maximum load current	5 to 40mA	5 to 20mA	20mA
Contact protection circuit	None		
Internal voltage drop	D-A93 – 2.4V or less (to 20mA)/ 3V or less (to 40mA) D-A93V – 2.7V or less		0.8V or less
Indicator light	Red LED lights when ON		

### • Lead wire

- D-A90(V), D-A93(V) — Oil resistant vinyl heavy duty cable ø2.7, 0.18mm<sup>2</sup> x 2-wire (brown, blue), 0.5m
  - D-A96(V) — Oil resistant vinyl heavy duty cable ø2.7, 0.15mm<sup>2</sup> x 3-wire (brown, black, blue), 0.5m
- Note 1) Refer to page 15 for reed state switch common specifications.  
Note 2) Refer to page 15 for lead wire length.

## Auto Switch Weights

Model	D-A90	D-A90V	D-A93	D-A93V	D-A96	D-A96V
Lead wire length 0.5m	6	6	6	6	8	8
Lead wire length 3m	30	30	30	30	41	41

(g)

## Auto Switch Dimensions

### D-A90, D-A93, D-A96

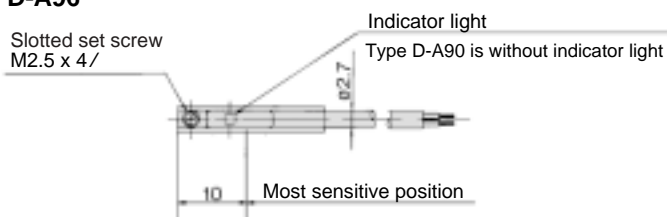

### D-A90V, D-A93V, D-A96V

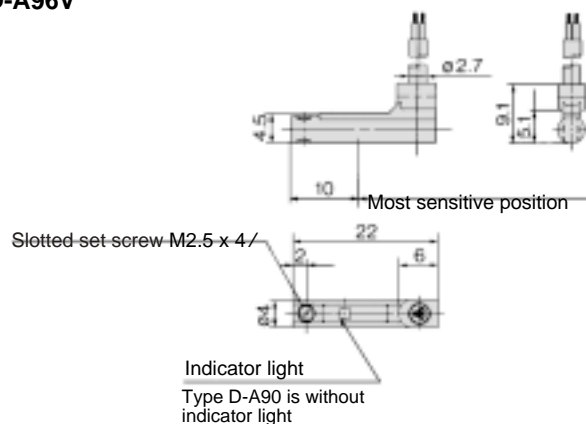

# Solid State Switches/Direct Mount Type D-F9N(V), D-F9P(V), D-F9B(V)

## Grommet



## Caution

### Precautions

Be sure to use fixing screws attached to the auto switch to secure the switch. Use of screws out of the specifications can damage the switch.

## Auto Switch Specifications

D-F9□, D-F9□V (with indicator light)						
Auto switch part no.	D-F9N	D-F9NV	D-F9P	D-F9PV	D-F9B	D-F9BV
Electrical entry direction	In-line	Perpendicular	In-line	Perpendicular	In-line	Perpendicular
Wiring type	3-wire				2-wire	
Output type	NPN		PNP		—	
Applicable load	IC circuit, Relay, PLC				24VDC relay, PLC	
Power supply voltage	5, 12, 24VDC (4.5 to 28V)				—	
Current consumption	10mA or less				—	
Load voltage	28VDC or less		—		24VDC (10 to 8V)	
Load current	40mA or less		80mA or less		5 to 40mA	
Internal voltage drop	1.5V or less (0.8V or less at 10mA load current)		0.8V or less		4V or less	
Leakage current	100μA or less at 24VDC				0.8mA or less	
Indicator light	Red LED lights when ON					

- Lead wire — Oil proof heavy duty vinyl cord,  $\phi 2.7$ , 3 cores (brown, black, blue), 0.15mm<sup>2</sup>, 2 cores (brown, blue), 0.18 mm<sup>2</sup>, 0.5m

Note 1) Refer to page 15 for solid state switch common specifications.

Note 2) Refer to page 15 for lead wire length.

## Auto Switch Weights

Unit: g

Model		D-F9N(V)	D-F9P(V)	D-F9B(V)
Lead wire length m	0.5	7	7	6
	3	37	37	31
	5	61	61	51

## Auto Switch Internal Circuits

### D-F9N, F9NV

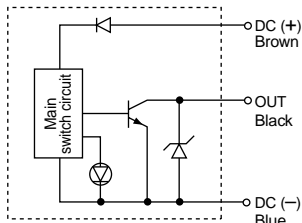

### D-F9P, F9PV

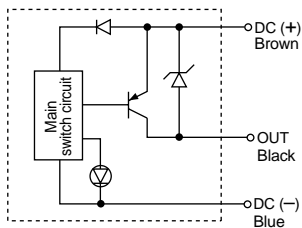

### D-F9B, F9BV

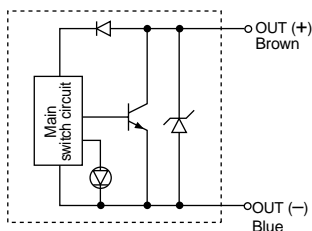

## Auto Switch Dimensions

### D-F9□

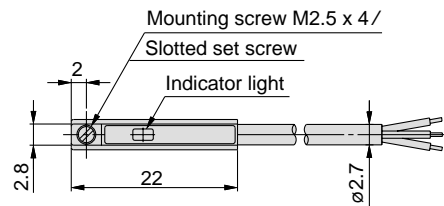
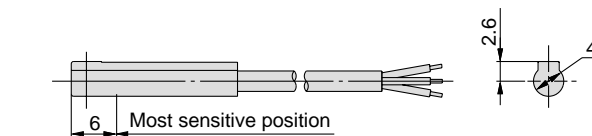

### D-F9□V

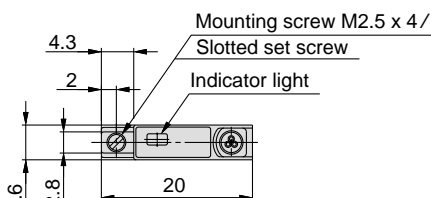
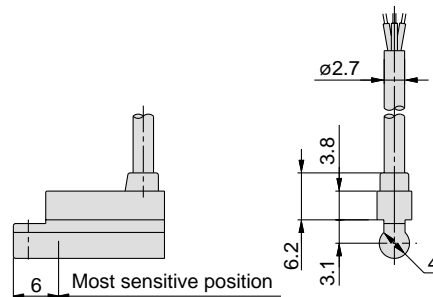

# 2-Color Display Solid State Switches/Direct Mount Type D-F9NW(V), D-F9PW(V), D-F9BW(V)

## Auto Switch Specifications

### Grommet

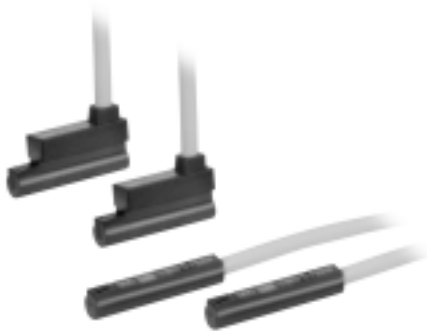

D-F9□W, D-F9□WV (with Indicator light)						
Auto switch part no.	D-F9NW	D-F9NWV	D-F9PW	D-F9PWV	D-F9BW	D-F9BWV
Electrical entry direction	In-line	Perpendicular	In-line	Perpendicular	In-line	Perpendicular
Wiring type	3-wire			2-wire		
Output type	NPN		PNP		—	
Applicable load	IC circuit, Relay IC, PLC				24VDC relay, PLC	
Power supply voltage	5, 12, 24VDC (4.5 to 28V)				—	
Current consumption	10mA or less				—	
Load voltage	28VDC or less		—		24VDC (10 to 28V)	
Load current	40mA or less		80mA or less		5 to 40mA	
Internal voltage drop	0.8V or less at 10mA load current		0.8V or less		4V or less	
Leakage current	100μA or less at 24VDC				0.8mA or less	
Indicator light	Actuated position ..... Red LED lights up Optimum operating position ... Green LED lights up					

### Auto Switch Internal Circuits

#### D-F9NW, F9NWV

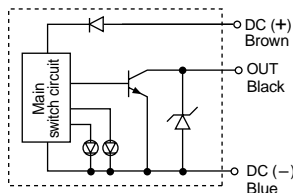

#### D-F9PW, F9PWV

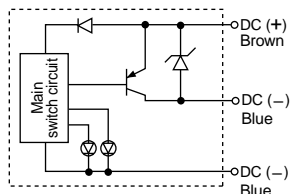

#### D-F9BW, F9BWV

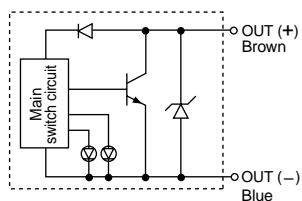

### Indicator light/Display method

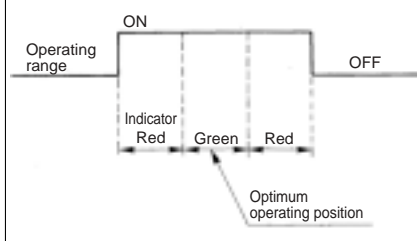

- Lead wire — Oil proof heavy duty vinyl cord,  $\phi 2.7$ , 3 cores (brown, black, blue), 0.15mm<sup>2</sup>, 2 cores (brown, blue), 0.18mm<sup>2</sup>, 0.5m

Note 1) Refer to page 15 for solid state switch common specifications.

Note 2) Refer to page 15 for lead wire length.

### Auto Switch Weights

Unit: g

Model		D-F9NW(V)	D-F9PW(V)	D-F9BW(V)
Lead wire length m	0.5	7	7	7
	3	34	34	32
	5	56	56	52

### Auto Switch Dimensions

#### D-F9□W

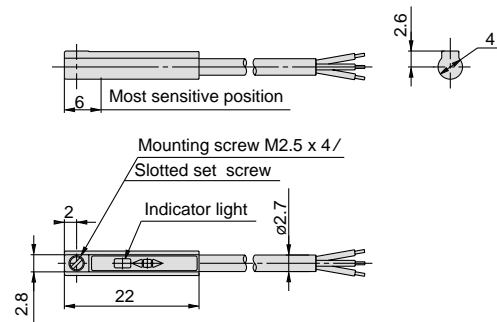

#### D-F9□WV

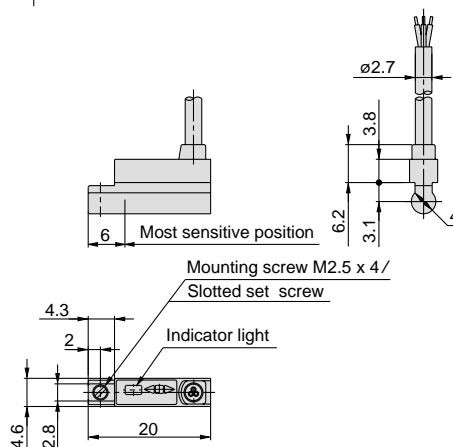



## 1 Intermediate stroke

Symbol

**-XB10**

Intermediate strokes are available within the standard stroke range.  
The stroke can be set in 1mm increments.

### Stroke range

Bore size (mm)	Stroke range (mm)
10	51 to 299
15	51 to 499
25	101 to 599

CY1F **Bore size** **Piping thread type** **Piping direction** **Stroke** **Adjustment bolt symbol** **Auto switch** **Symbol** **-XB10**

Example CY1F10R-237AL-A93-**XB10**

## 2 Long stroke

Symbol

**-XB11**

Available with long strokes exceeding the standard strokes.  
The stroke can be set in 1mm increments.

### Stroke range

Bore size (mm)	Stroke range (mm)
10	301 to 500
15	501 to 750
25	601 to 1200

CY1F **Bore size** **Piping thread type** **Piping direction** **Stroke** **Adjustment bolt symbol** **Auto switch** **Symbol** **-XB11**

Example CY1F25L-777A-A93-**XB11**









# Series CY1F Safety Instructions

These safety instructions are intended to prevent a hazardous situation and/or equipment damage. These instructions indicate the level of potential hazard by a label of "**Caution**", "**Warning**" or "**Danger**". To ensure safety, be sure to observe ISO 4414 Note 1), JIS B 8370 Note 2) and other safety practices.

 **Caution** : Operator error could result in injury or equipment damage.

 **Warning** : Operator error could result in serious injury or loss of life.

 **Danger** : In extreme conditions, there is a possible result of serious injury or loss of life.

Note 1) ISO 4414: Pneumatic fluid power – Recommendations for the application of equipment to transmission and control systems

Note 2) JIS B 8370: General Rules for Pneumatic Equipment

## **Warning**

### **1. The compatibility of pneumatic equipment is the responsibility of the person who designs the pneumatic system or decides its specifications.**

Since the products specified here are used in various operating conditions, their compatibility for the specific pneumatic system must be based on specifications or after analysis and/or tests to meet your specific requirements.

### **2. Only trained personnel should operate pneumatically operated machinery and equipment.**

Compressed air can be dangerous if handled incorrectly. Assembly, handling or repair of pneumatic systems should be performed by trained and experienced operators.

### **3. Do not service machinery/equipment or attempt to remove components until safety is confirmed.**

1. Inspection and maintenance of machinery/equipment should only be performed after confirmation of safe locked-out control positions.

2. When equipment is to be removed, confirm the safety process as mentioned above. Cut the supply pressure for this equipment and exhaust all residual compressed air in the system.

3. Before machinery/equipment is restarted, take measures to prevent shooting-out of cylinder piston rod, etc. (Bleed air into the system gradually to create back pressure.)

### **4. Contact SMC if the product is to be used in any of the following conditions:**

1. Conditions and environments beyond the given specifications, or if product is used outdoors.

2. Installation on equipment in conjunction with atomic energy, railway, air navigation, vehicles, medical equipment, food and beverages, recreation equipment, emergency stop circuits, press applications, or safety equipment.

3. An application which has the possibility of having negative effects on people, property, or animals, requiring special safety analysis.



# Series CY1F Actuator Precautions 1

Be sure to read before handling.

## Precautions on Design

### Warning

1. **There is a danger of sudden action by air cylinders if sliding parts of machinery are twisted, etc., and changes in forces occur.**

In such cases, human injury may occur; e.g., by catching hands or feet in the machinery, or damage to the machinery itself may occur. Therefore, the machine should be designed to avoid such dangers.

2. **Install a protective cover when there is a risk of human injury.**

If a driven object and moving parts of a cylinder pose a danger of human injury, design the structure to avoid contact with the human body.

3. **Securely tighten all mounting parts and connecting parts so that they will not become loose.**

Especially when a cylinder operates with high frequency or is installed where there is a lot of vibration, ensure that all parts remain secure.

4. **A deceleration circuit or shock absorber, etc., may be required.**

When a driven object is operated at high speed or the load is heavy, a cylinder's cushion will not be sufficient to absorb the impact. Install a deceleration circuit to reduce the speed before cushioning, or install an external shock absorber to relieve the impact. In this case, the rigidity of the machinery should also be examined.

5. **Consider a possible drop in operating pressure due to a power outage, etc.**

When a cylinder is used in a clamping mechanism, there is a danger of work pieces dropping if there is a decrease in clamping force due to a drop in circuit pressure caused by a power outage, etc. Therefore, safety equipment should be installed to prevent damage to machinery and/or human injury. Suspension mechanisms and lifting devices also require consideration for drop prevention.

6. **Consider a possible loss of power source.**

Measures should be taken to protect against human injury and equipment damage in the event that there is a loss of power to equipment controlled by air pressure, electricity or hydraulics, etc.

7. **Design circuitry to prevent sudden lurching of driven objects.**

When a cylinder is driven by an exhaust centre type directional control valve or when starting up after residual pressure is exhausted from the circuit, etc., the piston and its driven object will lurch at high speed if pressure is applied to one side of the cylinder because of the absence of air pressure inside the cylinder. In such cases, human injury may occur; e.g., by catching hands or feet in the machinery, or damage to the machinery itself may occur. Therefore, equipment should be selected and circuits designed to prevent sudden lurching.

8. **Consider emergency stops.**

Design so that human injury and/or damage to machinery and equipment will not be caused when machinery is stopped by a safety device under abnormal conditions, a power outage or a manual emergency stop.

9. **Consider the action when operation is restarted after an emergency stop or abnormal stop.**

Design the machinery so that human injury or equipment damage will not occur upon restart of operation. When the cylinder has to be reset at the starting position, install safe manual control equipment.

## Selection

### Warning

1. **Confirm the specifications.**

The products advertised in this catalogue are designed according to use in industrial compressed air systems. If the products are used in conditions where pressure, temperature, etc., are out of specification, damage and/or malfunction may be caused. Do not use in these conditions. (Refer to specifications.)

Consult SMC if you use a fluid other than compressed air.

2. **Intermediate stops**

When intermediate stopping of a cylinder piston is performed with a 3 position closed centre type directional control valve, it is difficult to achieve stopping positions as accurate and minute as with hydraulic pressure due to the compressibility of air.

Furthermore, since valves and cylinders, etc., are not guaranteed for zero air leakage, and it is not possible to hold a stopped position, do not use for this purpose. In case it is necessary to hold a stopped position, select equipment and design circuits to prevent movement.

### Caution

1. **Operate within the limits of the maximum usable stroke.**

Refer to the air cylinder model selection procedure for the maximum useable stroke.

2. **Operate the piston within a range such that collision damage will not occur at the stroke end.**

Operate within a range such that damage will not occur when the piston having inertial force stops by striking the cover at the stroke end. Refer to the cylinder model selection procedure for the range within which damage will not occur.

3. **Use a speed controller to adjust the cylinder drive speed, gradually increasing from a low speed to the desired speed setting.**

4. **Provide intermediate supports for long stroke cylinders.**

Provide intermediate supports for cylinders with long strokes to prevent bending of the tube, and deflection due to vibration and external loads, etc.



# Series CY1F Actuator Precautions 2

Be sure to read before handling.

## Mounting

### ⚠ Caution

#### 1. Do not apply strong impacts or excessive moment to the slide table (slider).

The slide table (slider) is supported by precision bearings. Therefore, do not apply strong impacts or excessive moment, etc., when mounting work pieces.

#### 2. Align carefully when connecting to a load having an external guide mechanism.

Magnetically coupled rodless cylinders (series CY1F) can be used with a direct load within the allowable range for each type of guide, but careful alignment is necessary when connecting to a load having an external guide mechanism.

As the stroke becomes longer, variations in the center axis become larger. Consider using a connection method (floating mechanism) that is able to absorb these variations.

#### 3. Do not scratch or gouge the cylinder tube by striking or grasping it with other objects.

Cylinder bores are manufactured to precise tolerances, so that even a slight deformation may cause malfunction.

#### 4. Do not use until you can verify that equipment can operate properly.

Verify correct mounting by suitable function and leakage inspections after compressed air and power are connected following mounting, maintenance or conversions.

#### 5. Instruction manual

The product should be mounted and operated after thoroughly reading the manual and understanding its contents.

Keep the instruction manual where it can be referred to as needed.

## Piping

### ⚠ Caution

#### 1. Preparation before piping

Before piping is connected, it should be thoroughly blown out with air (flushing) or washed to remove chips, cutting oil and other debris from inside the pipe.

#### 2. Wrapping of pipe tape

When screwing together pipes and fittings, etc., be certain that chips from the pipe threads and sealing material do not get inside the piping.

Also, when pipe tape is used, leave 1.5 to 2 thread ridges exposed at the end of the threads.

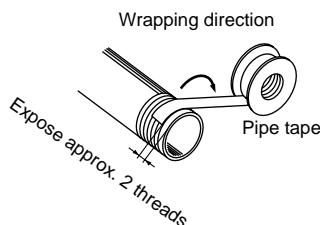

## Lubrication

### ⚠ Caution

#### 1. Lubrication of non-lube type cylinder

The cylinder is lubricated at the factory and can be used without any further lubrication.

However, in the event that it will be lubricated, use class 1 turbine oil (without additives) ISO VG32.

Stopping lubrication later may lead to malfunction due to the loss of the original lubricant. Therefore, lubrication must be continued once it has been started.

## Air Supply

### ⚠ Warning

#### 1. Use clean air.

Do not use compressed air which includes chemicals, synthetic oils containing organic solvents, salt or corrosive gases, etc., as it can cause damage or malfunction.

### ⚠ Caution

#### 1. Install air filters.

Install air filters at the upstream side of valves. The filtration degree should be 5µm or finer.

#### 2. Install an after cooler, air dryer or water separator, etc.

Air that includes excessive drainage may cause malfunction of valves and other pneumatic equipment. To prevent this, install an after cooler, air dryer or water separator, etc.

#### 3. Use the product within the specified range of fluid and ambient temperature.

Take measures to prevent freezing, since moisture in circuits can be frozen under 5°C, and this may cause damage to seals and lead to malfunction.

Refer to SMC's "Best Pneumatics vol.4" catalogue for further details on compressed air quality.



# Series CY1F Actuator Precautions 3

Be sure to read before handling.

## Operating Environment

### Warning

1. **Do not use in environments where there is a danger of corrosion.**

Refer to the construction drawings regarding cylinder materials.

2. **Provide a cover or other protection in dusty locations or where water, oil, etc., splash on the equipment.**

The cylinder may malfunction if operated in a location with a lot of dirt, water droplets, coolant or paper dust, etc. Provide a cover or other protective measure.

## Maintenance

### Warning

1. **Maintenance should be performed according to the procedure indicated in the instruction manual.**

If handled improperly, malfunction and damage of machinery or equipment may occur.

2. **Removal of equipment, and supply/exhaust of compressed air.**

When equipment is removed, first check measures to prevent dropping of driven objects and run-away of equipment, etc. Then cut off the supply pressure and electric power, and exhaust all compressed air from the system.

When machinery is restarted, proceed with caution after confirming measures to prevent cylinder lurching.

### Caution

1. **Drain flushing**

Remove drainage from air filters regularly.

(Refer to specifications.)



# Series CY1F Auto Switch Precautions 1

Be sure to read before handling.

## Design and Selection

### ⚠ Warning

#### 1. Confirm the specifications.

Read the specifications carefully and use this product appropriately. The product may be damaged or malfunction if it is used outside the range of specifications of current load, voltage, temperature or impact.

#### 2. Take precautions when multiple cylinders are used close together.

When multiple auto switch cylinders are used in close proximity, magnetic field interference may cause the switches to malfunction. Maintain a minimum cylinder separation of 40mm. (When the allowable separation is indicated for each cylinder series, use the specified value.)

#### 3. Pay attention to the length of time that a switch is ON at an intermediate stroke position.

When an auto switch is placed at an intermediate position of the stroke and a load is driven at the time the piston passes, the auto switch will operate, but if the speed is too great the operating time will be shortened and the load may not operate properly. The maximum detectable piston speed is:

$$V(\text{mm/s}) = \frac{\text{Auto switch operating range (mm)}}{\text{Load operating time}} \times 1000$$

#### 4. Keep wiring as short as possible.

##### <Reed switch>

As the length of the wiring to a load gets longer, the rush current at switching ON becomes greater, and this may shorten the product's life. (The switch will stay ON all the time.)

- 1) Use a contact protection box when the wire length is 5m or longer.

##### <Solid state switch>

- 2) Although wire length does not affect switch function, use wiring 100m or shorter.

#### 5. Take precautions for the internal voltage drop of the switch.

##### <Reed switch>

- 1) Switches with an indicator light (Except D-A96, A96V)
  - If auto switches are connected in series as shown below, take note that there will be a large voltage drop because of internal resistance in the light emitting diodes. (Refer to internal voltage drop in the auto switch specifications.)

[The voltage drop will be "n" times larger when "n" auto switches are connected.]

Even though an auto switch operates normally, the load may not operate.

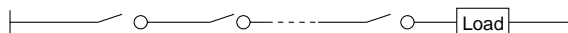

- In the same way, when operating below a specified voltage, although an auto switch may operate normally, the load may not operate. Therefore, the formula below should be satisfied after confirming the minimum operating voltage of the load.

$$\text{Supply voltage} - \text{Internal voltage drop of switch} > \text{Minimum operating voltage of load}$$

- 2) If the internal resistance of a light emitting diode causes a problem, select a switch without an indicator light (Model A90, A90V).

##### <Solid state switch>

- 3) Generally, the internal voltage drop will be greater with a 2-wire solid state auto switch than with a reed switch. Take the same precautions as in 1).

Also, note that a 12VDC relay is not applicable.

#### 6. Pay attention to leakage current.

##### <Solid state switch>

With a 2-wire solid state auto switch, current (leakage current) flows to the load to operate the internal circuit even when in the OFF state.

$$\text{Operating current of load (OFF condition)} > \text{Leakage current}$$

If the criteria given in the above formula are not met, it will not reset correctly (stays ON). Use a 3-wire switch if this specification will not be satisfied.

Moreover, leakage current flow to the load will be "n" times larger when "n" auto switches are connected in parallel.

#### 7. Do not use a load that generates surge voltage.

##### <Reed switch>

If driving a load such as a relay that generates a surge voltage, use a contact protection box.

##### <Solid state switch>

Although a zener diode for surge protection is connected at the output side of a solid state auto switch, damage may still occur if the surge is applied repeatedly. When a load, such as a relay or solenoid valve, which generates surge is directly driven, use a type of switch with a built-in surge absorbing element.

#### 8. Cautions for use in an interlock circuit

When an auto switch is used for an interlock signal requiring high reliability, devise a double interlock system to avoid trouble by providing a mechanical protection function, or by also using another switch (sensor) together with the auto switch. Also perform periodic maintenance and confirm proper operation.

#### 9. Ensure sufficient clearance for maintenance activities.

When designing an application, be sure to allow sufficient clearance for maintenance and inspections.



# Series CY1F Auto Switch Precautions 2

Be sure to read before handling.

## Mounting and Adjustment

### ⚠ Warning

#### 1. Do not drop or bump.

Do not drop, bump or apply excessive impacts (300m/s<sup>2</sup> or more for reed switches and 1000m/s<sup>2</sup> or more for solid state switches) while handling.

Although the body of the switch may not be damaged, the inside of the switch could be damaged and cause a malfunction.

#### 2. Do not carry a cylinder by the auto switch lead wires.

Never carry a cylinder by its lead wires. This may not only cause broken lead wires, but it may cause internal elements of the switch to be damaged by the stress.

#### 3. Mount switches using the proper tightening torque.

When a switch is tightened beyond the range of tightening torque, the mounting screws or switch may be damaged. On the other hand, tightening below the range of tightening torque may allow the switch to slip out of position.

#### 4. Mount a switch at the center of the operating range.

Adjust the mounting position of an auto switch so that the piston stops at the center of the operating range (the range in which a switch is ON). (The mounting positions shown in the catalog indicate the optimum positions at stroke end.) If mounted at the end of the operating range (around the borderline of ON and OFF), operation may be unstable.

## Wiring

### ⚠ Warning

#### 1. Avoid repeatedly bending or stretching lead wires.

Broken lead wires will result from repeatedly applying bending stress or stretching force to the lead wires.

#### 2. Be sure to connect the load before power is applied.

##### <2-wire type>

If the power is turned ON when an auto switch is not connected to a load, the switch will be instantly damaged because of excess current.

#### 3. Confirm proper insulation of wiring.

Be certain that there is no faulty wiring insulation (contact with other circuits, ground fault, improper insulation between terminals, etc.). Damage may occur due to excess current flow into a switch.

#### 4. Do not wire with power lines or high voltage lines.

Wire separately from power lines or high voltage lines, avoiding parallel wiring or wiring in the same conduit with these lines. Control circuits containing auto switches may malfunction due to noise from these other lines.

## Wiring

### ⚠ Warning

#### 5. Do not allow short circuit of loads.

##### <Reed switch>

If the power is turned ON with a load in a short circuit condition, the switch will be instantly damaged because of excess current flow into the switch.

##### <Solid state switch>

All models of PNP output type switches do not have built-in short circuit protection circuits. If loads are short circuited, the switches will be instantly damaged, as in the case of reed switches.

Take special care to avoid reverse wiring with the brown power supply line and the black output line on 3-wire type switches.

#### 6. Avoid incorrect wiring.

##### <Reed switch>

A 24VDC switch with indicator light has polarity. The brown lead wire or terminal no. 1 is (+), and the blue lead wire or terminal no. 2 is (-).

- 1) If connections are reversed, a switch will operate, however, the light emitting diode will not light up.

Also note that a current greater than that specified will damage a light emitting diode and it will no longer operate.

Applicable models: D-A93, A93V

##### <Solid state switch>

- 1) If connections are reversed on a 2-wire type switch, the switch will not be damaged if protected by a protection circuit, but the switch will be in a normally ON state. However, note that the switch will be damaged if reversed connections are made while the load is in a short circuited condition.
- 2) If connections are reversed (power supply line + and power supply line -) on a 3-wire type switch, the switch will be protected by a protection circuit. However, if the power supply line (+) is connected to the blue wire and the power supply line (-) is connected to the black wire, the switch will be damaged.

#### \* Lead wire colour changes

Lead wire colours of SMC switches have been changed in order to meet NECA Standard 0402 for production beginning September, 1996 and thereafter. Please refer to the tables provided. Special care should be taken regarding wire polarity during the time that the old colours still coexist with the new colors.

##### 2-wire

	Old	New
Output (+)	Red	Brown
Output (-)	Black	Blue

##### 3-wire

	Old	New
Power supply	Red	Brown
GND	Black	Blue
Output	White	Black

##### Solid state with diagnostic output

	Old	New
Power supply	Red	Brown
GND	Black	Blue
Output	White	Black
Diagnostic output	Yellow	Orange

##### Solid state with latch type diagnostic output

	Old	New
Power supply	Red	Brown
GND	Black	Blue
Output	White	Black
Latch type diagnostic output	Yellow	Orange



# Series CY1F Auto Switch Precautions 3

Be sure to read before handling.

## Operating Environment

### ⚠ Warning

#### 1. Never use in an atmosphere of explosive gases.

The construction of auto switches is not intended to prevent explosion. Never use in an atmosphere with an explosive gas since this may cause a serious explosion.

#### 2. Do not use in an area where a magnetic field is generated.

Auto switches will malfunction or magnets inside cylinders will become demagnetized. (Consult SMC regarding the availability of a magnetic field resistant auto switch.)

#### 3. Do not use in an environment where the auto switch will be continually exposed to water.

Although switches satisfy IEC standard IP67 construction (JIS C 0920: watertight construction), do not use switches in applications where continually exposed to water splash or spray. Poor insulation or swelling of the potting resin inside switches may cause malfunction.

#### 4. Do not use in an environment with oil or chemicals.

Consult SMC if auto switches will be used in an environment with coolant, cleaning solvent, various oils or chemicals. If auto switches are used under these conditions for even a short time, they may be adversely affected by improper insulation, malfunction due to swelling of the potting resin, or hardening of the lead wires.

#### 5. Do not use in an environment with temperature cycles.

Consult SMC if switches are used where there are temperature cycles other than normal air temperature changes, as they may be adversely affected internally.

#### 6. Do not use in an environment where there is excessive impact shock.

##### <Reed switch>

When excessive impact (300m/s<sup>2</sup> or more) is applied to a reed switch during operation, the contact will malfunction and generate or cut off a signal momentarily (1ms or less). Consult SMC regarding the need to use a solid state switch depending upon the environment.

#### 7. Do not use in an area where surges are generated.

##### <Solid state switch>

When there are units (solenoid type lifter, high frequency induction furnace, motor, etc.) which generate a large amount of surge in the area around cylinders with solid state auto switches, this may cause deterioration or damage to internal circuit elements of the switch. Avoid sources of surge generation and crossed lines.

#### 8. Avoid accumulation of iron debris or close contact with magnetic substances.

When a large amount of ferrous debris such as machining chips or welding spatter is accumulated, or a magnetic substance (something attracted by a magnet) is brought into close proximity with an auto switch cylinder, it may cause auto switches to malfunction due to a loss of the magnetic force inside the cylinder.

## Maintenance

### ⚠ Warning

#### 1. Perform the following maintenance periodically in order to prevent possible danger due to unexpected auto switch malfunction.

##### 1) Securely tighten switch mounting screws.

If screws become loose or the mounting position is dislocated, retighten them after readjusting the mounting position.

##### 2) Confirm that there is no damage to lead wires.

To prevent faulty insulation, replace switches or repair lead wires, etc., if damage is discovered.

##### 3) Confirm the lighting of the green light on a 2-color display type switch.

Confirm that the green LED is on when stopped at the established position. If the red LED is on, the mounting position is not appropriate. Readjust the mounting position until the green LED lights up.

## Other

### ⚠ Warning

#### 1. Consult SMC concerning water resistance, elasticity of lead wires and usage at welding sites, etc.



# Series CY1F

## Specific Product Precautions 1

Be sure to read before handling.

### Mounting

#### ⚠ Caution

##### 1. Do not apply a large impact or excessive moment to the slide table (slider).

Because the slide table (slider) is supported by a precision bearing, do not apply a large impact or excessive moment when mounting a work piece.

##### 2. Align carefully when connecting to a load with an external guide mechanism.

Although a magnetic rodless cylinder (series CY1F) can directly receive a load within the allowable range of the guide, it is necessary to align sufficiently when connecting to a load with an external guide mechanism.

The longer the stroke is, the greater the displacement of the shaft center becomes. Therefore, adopt a connection method (floating mechanism) that can ensure absorption of the displacement.

##### 3. Be sure to use the 4 mounting holes on both ends of the guide body when mounting the product on equipment.

The mounting hole at the center of the guide body is used to mount an intermediate support. Be sure to use the 4 mounting holes at both ends to secure the product.

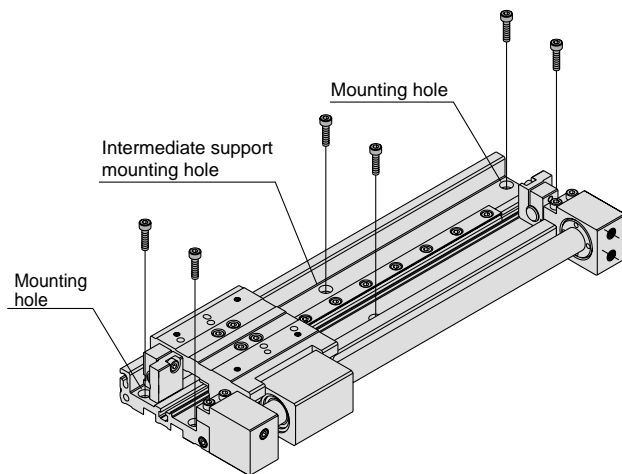

##### 4. When a 25 mm adjustment bolt is selected, the mounting holes will be hidden behind it. Adjust the adjustment bolt after the cylinder is installed.

According to (2) "Adjusting bolt adjustment" on page 31, move the adjustment bolt to a position where it does not interfere with any of the mounting holes and secure the cylinder with mounting screws. After securing the cylinder, readjust the stroke with the adjustment bolt.

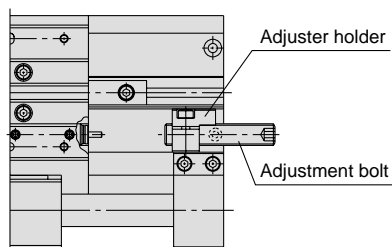

25 mm adjustment bolt

#### ⚠ Caution

##### 5. Long stroke operation causes deflection of the path table or cylinder tube. In such a case, provide an intermediate support.

Provide an intermediate support with the mounting holes on the center of the path table so that the distance between supports given as L in the figure will not exceed the value shown in the graph.

- If the counter surface lacks precision, malfunction may result so adjust the level at the same time.
- In an environment where vibration or impact occurs, provide an intermediate support even if the distance is within the allowable range in the graph.

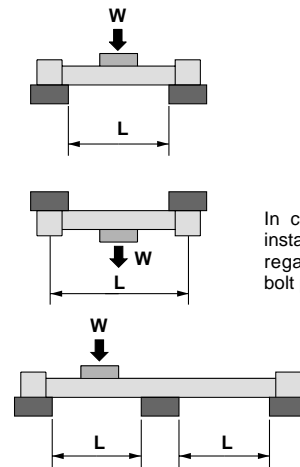

In case the product is installed on the ceiling, regard the mounting bolt pitch as L.

Distance between load and supports

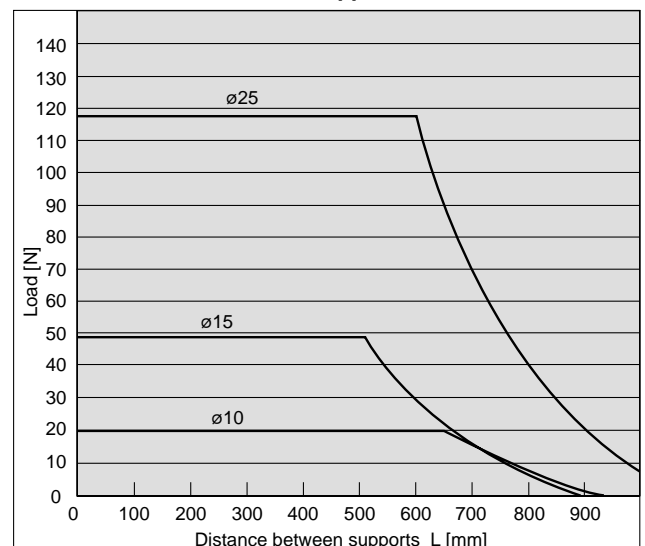

##### 6. There are limitations on the load mass and operating pressure in case the product is used in the vertical direction.

When using the product in the vertical direction, confirm the allowable values in "Vertical Operation" in Model Selection (1). If the allowable value is exceeded, the magnet coupling may slip off, causing the work piece to drop down.





## Series CY1F

# Specific Product Precautions 2

Be sure to read before handling.

### Handling

#### ⚠ Caution

##### 1. Do not inadvertently move the guide adjusting unit.

The guide is installed at the proper tightening torque. Do not loosen the mounting bolts of the guide.

##### 2. Do not operate the magnetic rodless cylinder if the magnet couplings on the actuator are displaced.

If the magnet couplings are displaced by an external force beyond the holding force, supply an air pressure of 0.7MPa to the cylinder port to return the external slider to the right position of the stroke end.

##### 3. Take precautions to avoid getting your hands caught in the unit.

Be careful not to let your hand caught between the slide table and adjuster holder at the stroke end. Install a protective cover or take some other measures to keep any part of the human body from directly touching the place.

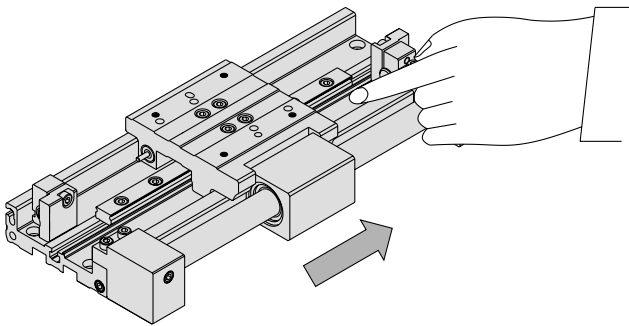

##### 4. Never disassemble the magnetic component parts (external slider, internal slider) of the actuator (cylinder).

If will cause decline of the holding force, etc.

### Piping

#### ⚠ Caution

##### 1. Be careful about the direction of the piping port and that of the slide table movement.

The direction of the piping port and that of the slide table movement differ between the right side centralized piping and left side centralized piping.

##### Centralized piping on right

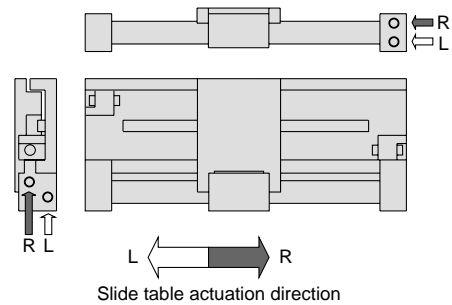

##### Centralized piping on left

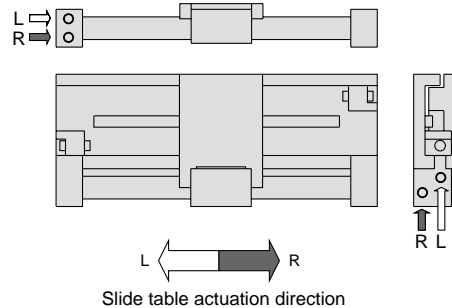

##### 2. The plug position of the piping port can be changed to suit the operating conditions.

When screwing in the plug for the second time, wrap a sealant tape around the plug to prevent leakage.

(1) M5

First tighten lightly until the rotation stops. Then tighten an additional 1/6 to 1/4 turn.

(2) Rc1/8

Tighten with a 7 to 9N·m torque using tightening tools.



# Series CY1F Specific Product Precautions 3

Be sure to read before handling.

## Adjustment

### ⚠ Caution

#### 1. Stroke adjustable range

The stroke of series CY1F can be controlled by adjusting the attached adjustment bolt.

For stroke adjustment amount, please refer to the table below.

Bore size (mm)	Standard adjustment bolt	25mm adjustment bolt
10	-1.2 to 0.8	-25.2 to 0.8
15		
25	-1.4 to 0.6	-25.4 to 0.6

(mm)

The adjustment values above are those for one side.

#### 2. Adjusting bolt adjustment

- Loosen the adjustment bolt fixing bolts.
- Insert a hexagon wrench into a hexagon hole at the end of the adjustment bolt to adjust the adjustment bolt.
- After adjustment, tighten the adjustment bolt fixing bolts.

Bore size (mm)	Adjustment bolt fixing bolts	Tightening torque	Adjustment width across flats
10	M3	1.0 to 1.3N·m	4
15			
25	M5	4.6 to 6.2N·m	5

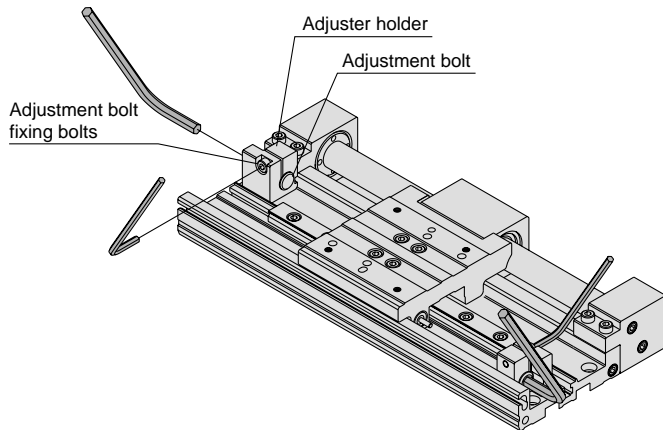

### ⚠ Caution

#### 1. When adjusting the stroke, be careful about the operating pressure limits.

When making the stroke smaller than the reference stroke with the adjustment bolt, operate at a pressure below the operating pressure limit in (1) "Intermediate stop by external stopper or stroke adjustment with adjustment bolt." on page 5. If the operating pressure limit is exceeded, the magnet coupling on the actuator (cylinder) will slip off.

#### 2. When adjusting the stroke, use the distance from the end of the adjustment bolt to the end of the adjuster holder as a guideline.

If dimension A is made smaller than 0, the slide table and adjuster holder will collide, resulting in damage to the slide table such as scratches or gouges.

(mm)

Bore size (mm)	At the minimum stroke of standard adjustment bolt	At the minimum stroke of 25 mm adjustment bolt	Basic stroke	At maximum stroke adjustment
10	A < 2	A < 26	A = 0.8	A ≥ 0
15				
25	A < 2	A < 26	A = 0.6	

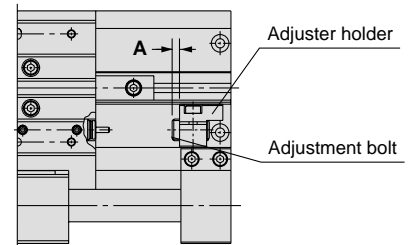

Standard adjustment bolt

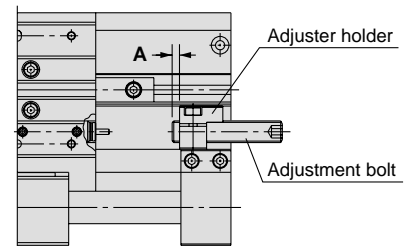

25 mm adjustment bolt



# Series CY1F

## Specific Product Precautions 4

Be sure to read before handling.

### Maintenance and Replacement

#### ⚠ Caution

##### Replacement of actuator

### 1. The actuator (cylinder) of series CY1F can be replaced.

Refer to "Replacement Actuator (Cylinder)" on page 11 about how to order.

### 2. Replacement of actuator (cylinder) of series CY1F.

- 1) Remove the 4 cylinder fixing bolts and pull out the actuator from the guide.
- 2) Apply grease to the gaskets attached to the replacement actuator (cylinder) and replace the installed gaskets with the new ones.
- 3) Fit the slider of the replacement actuator into the recessed part of the slide table. Align the surface C (on the side with round mounting holes) of the end cover of the replacement actuator and surface D of the stepped part on the guide.
- 4) In the condition described in (3), put surface A and surface B in close contact with each other. Tighten the 4 cylinder fixing bolts evenly.

Bore size (mm)	Cylinder fixing bolt	Tightening torque
10	M3	0.55 to 0.72N·m
15		
25	M5	2.6 to 3.5N·m

#### Enlarged view of stepped part

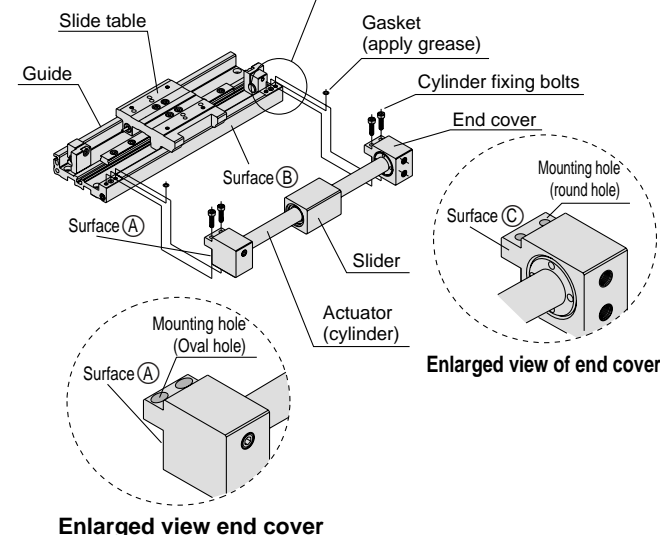
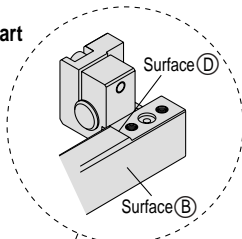

#### ⚠ Caution

##### Replacement of shock absorber

### 1. The shock absorber of series CY1F can be replaced.

The shock absorber should be replaced as a spare part if a decline in the energy absorption capacity is observed.

Refer to the table below about how to order a replacement shock absorber.

Bore size (mm)	No.
10	RB0805-X552
15	
25	RB1006-X552

### 2. Replacement of shock absorber

Follow the steps below to replace the shock absorber.

- 1) Remove the work piece from the slide table.
- 2) Loosen the 4 hexagon socket head screws on the top of the slide table and pull out the shock absorber.
- 3) Insert the replacement shock absorber into the slide table until it reaches the rear end and tighten 4 hexagon socket head screws.

Bore size (mm)	Hexagon socket head set screw	Tightening torque
10	M3	0.37 to 0.45N·m
15		
25	M5	0.54 to 0.64N·m

### 3. Be careful about the tightening torque of the hexagon socket head screws.

Be careful excessive tightening may cause damage or malfunction of the shock absorber.

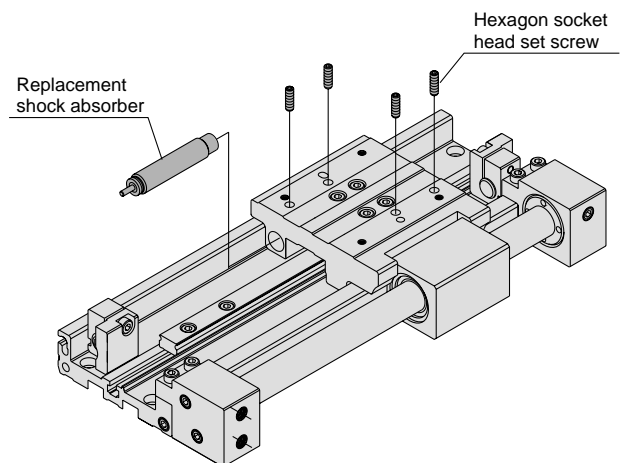

### 3. Be sure to fasten the cylinder fixing bolts.

Fasten the cylinder fixing bolts firmly. If they become loose, damage or malfunction may result. After replacing the actuator, be sure to conduct a test run before actually using the product.

**Austria**

SMC Pneumatik GmbH (Austria).  
Girakstrasse 8, A-2100 Korneuburg  
Phone: 02262-62280, Fax: 02262-62285

**Germany**

SMC Pneumatik GmbH  
Boschring 13-15, D-63329 Egelsbach  
Phone: 06103-4020, Fax: 06103-402139

**Netherlands**

SMC Pneumatics BV  
Postbus 308, 1000 AH Amsterdam  
Phone: 020-5318888, Fax: 020-5318880

**Slovenia**

SMC Slovenia d.o.o.  
Grajski trg 15, 8360 Zuzemberk  
Phone: 068-88 044 Fax: 068-88 041

**Belgium**

SMC Pneumatics N.V./S.A.  
Nijverheidsstraat 20, B-2160 Wommelgem  
Phone: 03-355-1464, Fax: 03-355-1466

**Greece**

S. Parianopoulos S.A.  
9, Konstantinoupoleos Street,  
GR-11855 Athens  
Phone: 01-3426076, Fax: 01-3455578

**Norway**

SMC Pneumatics Norway AS  
Vollsveien 13 C, Granfoss Næringspark  
N-1324 Lysaker  
Tel: (47) 67 12 90 20, Fax: (47) 67 12 90 21

**Spain**

SMC España, S.A.  
Zuazobidea 14, Pol. Ind. Jundiz,  
E-01015 Vitoria  
Phone: 945-184 100, Fax: 945-184 124

**Czech**

SMC Czech s.r.o.  
Kodanska 46, CZ-100 10 Prague 10  
Phone: 02-67154 790, Fax: 02-67154 793

**Hungary**

SMC Hungary Kft.  
Budafoki ut 107-113, 1117 Budapest  
Phone: 01-204 4366, Fax: 01-204 4371

**Poland**

Semac Co., Ltd.  
PL-05-075 Wesola k/Warszawy, ul. Wspolna 1A  
Phone: 022-6131847, Fax: 022-613-3028

**Sweden**

SMC Pneumatics Sweden A.B.  
Ekhagsvägen 29-31, S-14105 Huddinge  
Phone: 08-603 07 00, Fax: 08-603 07 10

**Denmark**

SMC Pneumatik  
Knudsmide 4B, DK-8300 Odder  
Phone: (45)70252900, Fax: (45)70252901

**Ireland**

SMC Pneumatics (Ireland) Ltd.  
2002 Citywest Business Campus,  
Naas Road, Saggart, Co. Dublin  
Phone: 01-403 9000, Fax: 01-464 0500

**Portugal**

SMC España (Sucursal Portugal), S.A.  
Rua de Engº Ferreira Dias 452, 4100 Porto  
Phone: 02-610-89-22, Fax: 02-610-89-36

**Switzerland**

SMC Pneumatik AG  
Dorfstrasse 7, CH-8484 Weisslingen  
Phone: 052-396-3131, Fax: 052-396-3191

**Estonia**

Teknoma Eesti AS  
Mustamäe tee 5, EE-0006 Tallinn, Estonia  
Phone: 259530, Fax: 259531

**Italy**

SMC Italia S.p.A  
Via Garibaldi 62, I-20061 Carugate, (Milano)  
Phone: 02-92711, Fax: 02-92150394

**Romania**

SMC Romania srl  
Vasile Stroescu 19, Sector 2, Bucharest  
Phone: 01-210-1354, Fax: 01-210-1680

**Turkey**

Entek Pnömatik San. ve Tic Ltd. Sti.  
Perpa Tic. Merkezi Kat: 11 No: 1625,  
TR-80270 Okmeydani Istanbul  
Phone: 0212-221-1512, Fax: 0212-220-2381

**Finland**

SMC Pneumatiikka OY  
Veneentekijäntie 7, SF-00210 Helsinki  
Phone: 09-681021, Fax: 09-6810233

**Latvia**

Ottensten Latvia SIA  
Ciekurkalna Prima Gara Linija 11,  
LV-1026 Riga, Latvia  
Phone: 371-23-68625, Fax: 371-75-56748

**Russia**

SMC Pneumatik LLC.  
36/40 Sredny pr. St. Petersburg 199004  
Phone: (812) 118 5445, Fax: (812) 118 5449

**UK**

SMC Pneumatics (UK) Ltd  
Vincent Avenue, Crownhill,  
Milton Keynes, MK8 0AN  
Phone: 01908-563888 Fax: 01908-561185

**France**

SMC Pneumatique, S.A.  
1, Boulevard de Strasbourg, Parc Gustave Eiffel  
Bussy Saint Georges  
F-77607 Marne La Vallée Cedex 3  
Phone: 01-6476 1000, Fax: 01-6476 1010

**Lithuania**

UAB Ottensten Lietuva  
Savanoriu pr.180, LT-2600 Vilnius, Lithuania  
Phone/Fax: 370-2651602

**Slovakia**

SMC Slovakia s.r.o.  
Pribinova ul. C. 25, 819 02 Bratislava  
Phone: 0-563 3548, Fax: 07-563 3551

**OTHER SUBSIDIARIES WORLDWIDE:**

ARGENTINA, AUSTRALIA, BOLIVIA, BRASIL, CANADA, CHILE, CHINA, HONG KONG, INDIA, MALAYSIA, MEXICO, NEW ZEALAND, PHILIPPINES, SINGAPORE, SOUTH KOREA, TAIWAN, THAILAND, USA, VENEZUELA

**SMC UK Contact Numbers**

Head Office: SMC Pneumatics (UK) Ltd, Vincent Avenue, Crownhill, Milton Keynes MK8 0AN

**THE NATIONAL SALES CENTRE FOR ENGLAND & WALES****Internal Sales**

*(Price, Delivery Information & Order Placement)*

Freephone: 0800 138 2930 Fax: 01908 555064  
e-mail: sales@smcpneumatics.co.uk

**Customer Services**

*(Post-Order Resolution)*

Freephone: 0800 138 2931 Fax: 01908 555065  
e-mail: customerservice@smcpneumatics.co.uk

**TECHNICAL CENTRE**

Freephone: 0800 138 2932 Fax: 01908 555066  
e-mail: technical@smcpneumatics.co.uk

**SMC FAST RESPONSE**

*(Literature & Catalogue Requests)*

0800 0262006

**SMC SALES CENTRE FOR SCOTLAND & N. IRELAND**

Tel: 01236 781133 Fax: 01236 780611

SMC Pneumatics (UK) Ltd, 1 Carradale Crescent, Broadwood Business Park, Cumbernauld, Glasgow G69 9LE

**SMC UK Sales Partners**

**Birmingham**  
JAMES LISTER  
Tel: 0121 5803800  
Fax: 0121 5535951

**Bristol**  
APPLIED AUTOMATION  
Tel: 0117 9827769  
Fax: 0117 9235522

**Cardiff**  
WALES FLUID POWER  
Tel: 02920 494551  
Fax: 02920 481955

**Blackburn**  
BLACKBURN PNEUMATIC SYSTEMS LTD  
Tel: 01254 682232  
Fax: 01254 682224

**Bury St Edmunds**  
PNEUMATIC LINES  
Tel: 01284 706239  
Fax: 01284 761218

**Plymouth**  
APPLIED AUTOMATION  
Tel: 01752 343300  
Fax: 01752 341161