

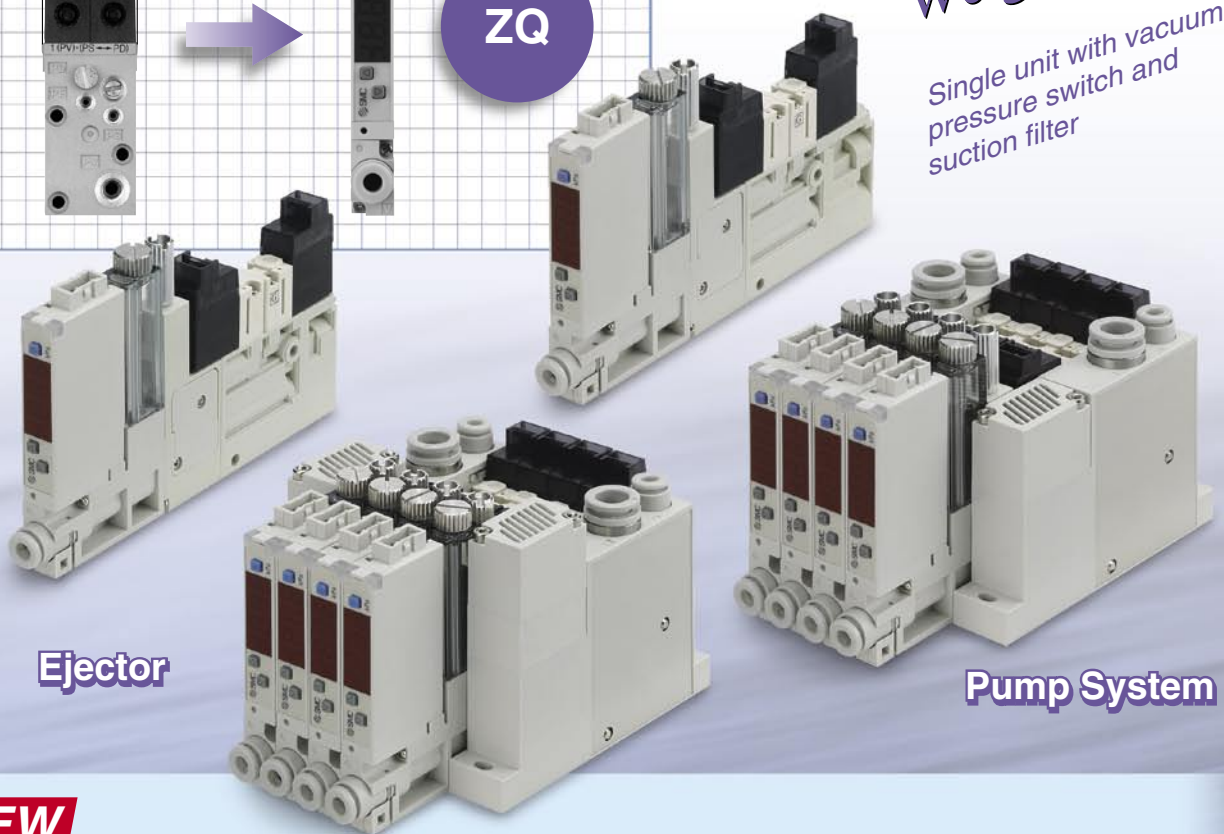

Space Saving Vacuum Ejector / Vacuum Pump System

Series ZQ
 Width 10 mm
 Weight 109 g

Single unit with vacuum pressure switch and suction filter

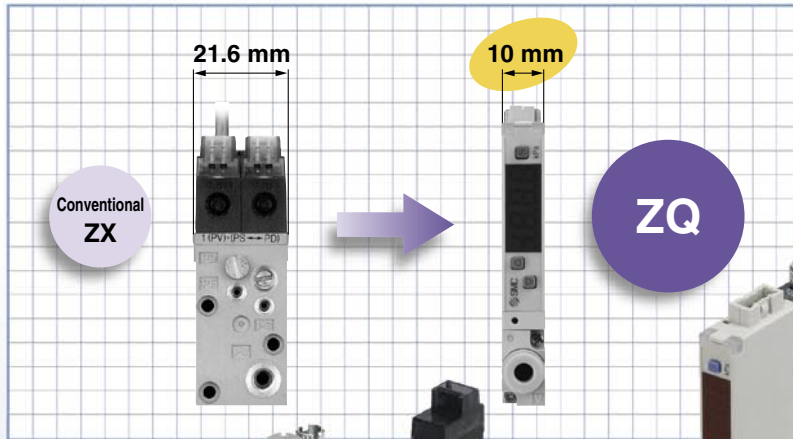

Ejector

Pump System

NEW

Easy-to-use vacuum pressure switch

- Push button type provides easy operation.



■ Vacuum pressure switch with LED display

■ With One-touch fittings

- NPN open collector 1 output + analogue voltage
- PNP open collector 1 output + analogue voltage
- NPN open collector 2 outputs
- PNP open collector 2 outputs



Can copy to up to 10 switches simultaneously.

The settings of the master pressure switch (source of copy) can be copied to the slave pressure switches.

- Reduction in setting work
- Prevention of mistakes in setting

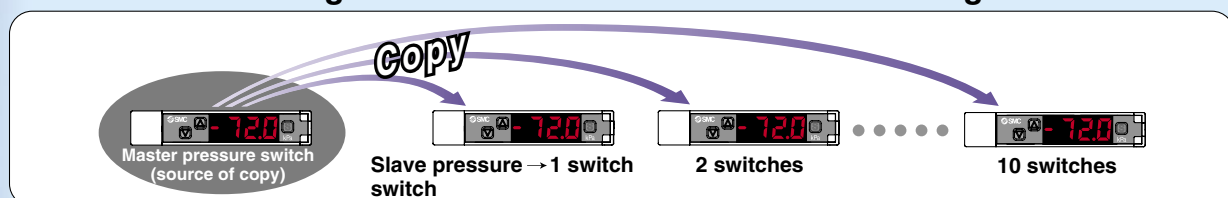

Space Saving Vacuum Ejector Series ZQ

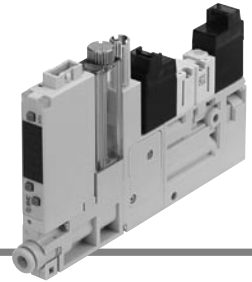

How to Order

Ejector Unit

Made to Order For "Made to Order", refer to page 13.

ZQ1 **05** **1U** - **K1** **5** **L** - **EA** **G** - **Q**

① ② ③ ④ ⑤ ⑥ ⑦ ⑧ ⑨ ⑩ ⑪ ⑫ ⑬

① Nozzle nominal size

05	ø0.5
07	ø0.7
10	ø1.0

② Exhaust type

1U	With silencer for single unit
3M	With silencer for manifold

③ Solenoid valve combination

Symbol	Supply valve	Vacuum release valve
K1	Normally closed	Normally closed
K2 <small>Note 1)</small>	Normally open	Normally closed
J1	Normally closed	None
J2 <small>Note 1)</small>	Normally open	None
Q1	Latching positive common	Normally closed
Q2	Latching positive common	None
N1	Latching negative common	Normally closed
N2	Latching negative common	None

Note 1) In cases when K2 or J2 (supply valve normally open) is selected for the solenoid valve combination, when vacuum is stopped for long periods of time (10 minutes or more), do not continue to energize the supply valve, and shut off the air supply.

④ Pilot valve (Refer to Table (1).)

—	Standard (DC: 1 W) <small>Note 2)</small>
Y	DC low wattage type (0.5 W) <small>Note 2)</small>

Note 2) Avoid energizing the solenoid valve for long periods of time. (Refer to Design and Selection on Specific Product Precautions.)

⑤ Solenoid valve rated voltage

5	24 VDC
6	12 VDC

⑥ Electrical entry

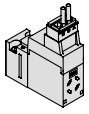
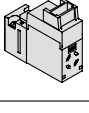
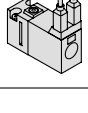
L	L-type plug connector, with 0.3 m lead wire, with light/surge voltage suppressor	
LO	L-type plug connector, without connector, with light/surge voltage suppressor	
G	Grommet, with 0.3 m lead wire	

⑦ Manual override Note 3)

—	Non-locking push type Latching type: Push-locking type
B	Locking type (Q1/Q2/N1/N2: Not applicable)

Note 3) Latching type supply valve: Available in “—” only.
In this case, the supply valve and release valve come with a push-locking type.

⑧ Vacuum pressure switch suction filter Note 4)

EA	0 to -101 kPa/NPN open collector 2 outputs, with suction filter
EB	0 to -101 kPa/PNP open collector 2 outputs, with suction filter
EC	0 to -101 kPa/NPN open collector 1 output + analogue voltage, with suction filter
EE	0 to -101 kPa/PNP open collector 1 output + analogue voltage, with suction filter
FA	100 to -100 kPa/NPN open collector 2 outputs, with suction filter
FB	100 to -100 kPa/PNP open collector 2 outputs, with suction filter
FC	100 to -100 kPa/NPN open collector 1 output + analogue voltage, with suction filter
FE	100 to -100 kPa/PNP open collector 1 output + analogue voltage, with suction filter
F	Suction filter only

Note 4) The filter included in this product is of a simple type, and will become clogged quickly in environments with high quantities of dust or particulates. Please make additional use of an air suction filter of the ZFA, ZFB or ZFC series.

⚠ Warning

The filter case of this suction filter is made of nylon. Contact with alcohol or similar chemicals may cause it to be damaged. Also, do not use the filter when these chemicals are present in the atmosphere.

⑪ Check valve Note 7)

—	None
K	With check valve

Note 7) The check valve has a function to prevent the exhaust air from the silencer overflowing to the vacuum port side when a manifold is used. However, depending on usage conditions, it does not always suppress air overflow to the desired extent. During usage, please inspect thoroughly with actual machine.

Also, in order to completely prevent the overflow of exhaust air, leave plenty of space between the check valve unit and adjacent ejector to avoid interference from the ejector's exhaust unit.

⚠ Warning

- ① Cannot be used for vacuum retention.
- ② Use a release valve. (Without a release valve, a workpiece may not be released.)

⑫ Fitting (V port) Note 8)

Symbol	Applicable tubing O.D.	Part no.	
		Vacuum pressure switch	Filter only
0	Without fitting (M5 x 0.8)	VVQ1000-50A-M5	—
1	ø3.2 (Straight)	VVQ1000-50A-C3	KJS23-M5
2	ø4 (Straight)	VVQ1000-50A-C4	KJS04-M5
3	ø6 (Straight)	VVQ1000-50A-C6	KJS06-M5
4	ø3.2 (Elbow)	VVQ1000-F1-LC3	KJL23-M5
5	ø4 (Elbow)	VVQ1000-F1-LC4	KJL04-M5

⑬ Fitting (P port) Note 8)

Symbol	Applicable tubing O.D.	Part no.	Object spec.
—	Without port	—	Manifold
0	Without fitting (M5 x 0.8)	—	Single unit
2	ø4 (Straight)	KJS04-M5	
3	ø6 (Straight)	KJS06-M5	
5	ø4 (Elbow)	KJL04-M5	

Note 8) For filter only (Without vacuum pressure switch)

When neither V port fitting nor P port fitting are needed, enter nothing or -00 in the dotted line above “How to Order”.

⑨ Vacuum pressure switch unit specifications

—	With unit switching function <small>Note 5)</small>
M	Fixed SI unit <small>Note 6)</small>
P	With unit switching function <small>Note 5)</small> (Initial value psi)

Note 5) Under the New Measurement Law, sales of switches with the unit switching function are not allowed for use in Japan.

Note 6) Fixed unit: kPa

⑩ Vacuum pressure switch lead wire specifications

—	Without connector
G	Lead wire with connector (Lead wire length 2 m) With connector cover

Series ZQ

How to Order

Manifold **ZZQ1 07 - B S C**

Number of stations (Note) **01** 1 station
02 2 stations
 ⋮
08 8 stations

Air pressure supply (P) port position
B Both sides

Exhaust
S With silencers (Both sides)

Vacuum release pressure supply port (PD port)
B None (Release pressure is supplied from the P port.)
C Provided (Air can be alternatively supplied from the P port.)

Note) Number of stations varies according to nozzle nominal size during simultaneous operation.

Maximum Number of Stations in Simultaneous Operation

Nozzle nominal size	Maximum number of stations in simultaneous operation
ø0.5	8 stations
ø0.7	6 stations
ø1.0	4 stations



Flow/Exhaust Characteristics

ZQ105 / Exhaust Characteristics

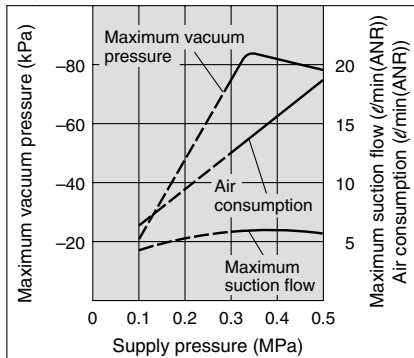

ZQ105 / Flow Characteristics

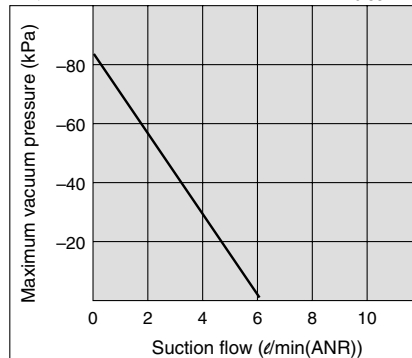

ZQ107 / Exhaust Characteristics

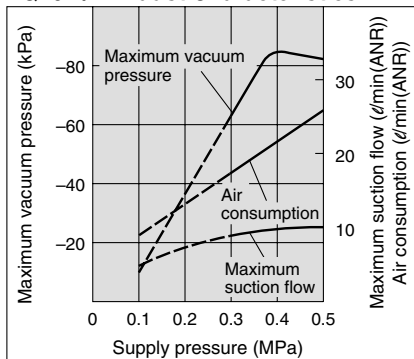

ZQ107 / Flow Characteristics

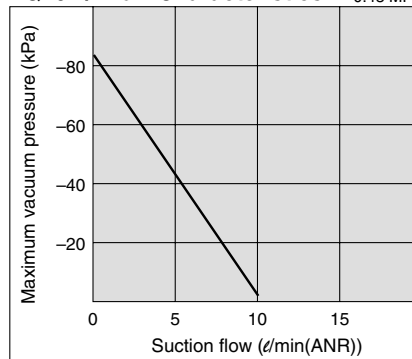

ZQ110 / Exhaust Characteristics

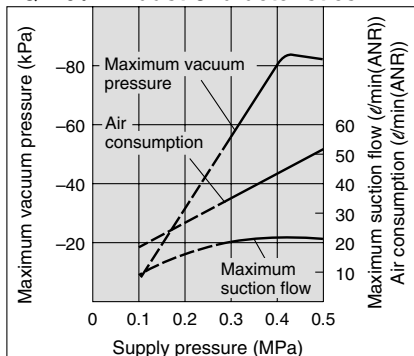

ZQ110 / Flow Characteristics

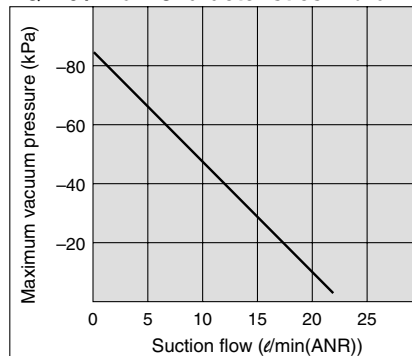

Manifold Ordering Example

- ZZQ108-BSB → 1 pc.
 *ZQ1053M-K1Y5L-EAG-Q → 4 pcs. (Stations 1 to 4)
 *ZQ1103M-K1Y5L-EAG-Q → 4 pcs. (Stations 5 to 8)

Note) By viewing the front side of vacuum port (V), stations are counted starting from station 1 on the left side.

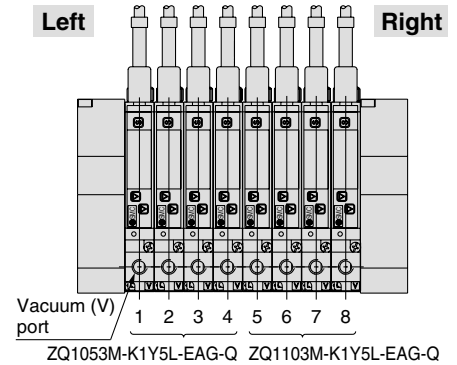

How to Read Flow Characteristics

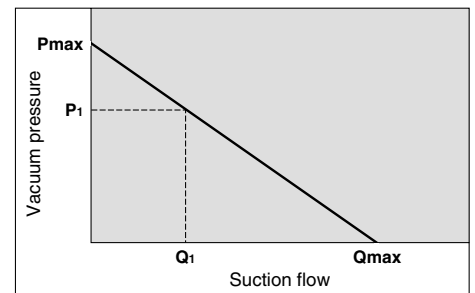

Flow characteristics are expressed in ejector vacuum pressure and suction flow. If suction flow rate changes, a change in vacuum pressure will also be expressed. Normally this relationship is expressed in ejector standard use.

In the graph, **Pmax** is max. vacuum pressure and **Qmax** is max. suction flow. The valves are specified according to catalogue use. Changes in vacuum pressure are expressed in the below order.

1. When ejector suction port is covered and made airtight, suction flow becomes 0 and vacuum pressure is at maximum value (**Pmax**).
2. When suction port is opened gradually, air can flow through, (air leakage), suction flow increases, but vacuum pressure decreases. (condition **P1** and **Q1**)
3. When suction port is opened further, suction flow moves to maximum value (**Qmax**), but vacuum pressure is near 0. (atmospheric pressure).

When vacuum port (vacuum piping) has no leakage, vacuum pressure becomes maximum, and vacuum pressure decreases as leakage increases. When leakage value is the same as max. suction flow, vacuum pressure is near 0.

When ventirative or leaky work must be adsorbed, please note that vacuum pressure will not be high.

⚠ Precautions

Be sure to read before handling. Refer to "Handling Precautions for SMC Products" (M-E03-3) for Safety Instructions and Vacuum Equipment Precautions.

⚠ Caution

Refer to the vacuum equipment model selection on Best Pneumatics No.④ for the selecting and sizing of Series ZQ.

Specifications

Ejector

Model	ZQ105	ZQ107	ZQ110
Nozzle nominal diameter (mm)	0.5	0.7	1.0
Maximum suction flow (ℓ/min (ANR))	5	10	22
Air consumption (ℓ/min (ANR))	14	23	46
Maximum vacuum pressure	-80 kPa		
Supply pressure range	0.3 to 0.5 MPa (Normally open: 0.3 to 0.45 MPa)		
Supply pressure ^{Note)}	0.35 MPa	0.43 MPa	
Operating temperature range	5 to 50°C		
Fluid	Air / Inert gas		

Note) Maximum suction flow can be obtained by standard supply pressure.

Weight

Single unit	With suction filter ^{Note 1)}	95 g
	With vacuum pressure switch and suction filter ^{Note 2)}	109 g
End plate assembly for manifold		122 g

Note 1) Including a 0.3 m connector for supply valve and vacuum release valve.

Note 2) Including a 0.3 m connector for supply valve and vacuum release valve and a 2 m connector for vacuum pressure switch.

◎ Calculation of weight for the manifold type

(Single unit weight) x (Number of stations) + (Weight of end plate assembly for manifold)

Example) Vacuum pressure switch + 8 stations with suction filter

$$109 \text{ g} \times 8 + 122 \text{ g} = 994 \text{ g}$$

Supply Valve / Vacuum Release Valve

Type	Normally closed		Latching type	Normally open
	Standard (1 W)	Low wattage type (0.5 W)		
Model (Refer to "How to Order" for solenoid valves on page 6.)	VQ110-□	VQ110Y-□	VQ110 _N -□	ZQ1-VQ120-□
Manual override	Non-locking push type / Locking type (Tool type)		Push-locking type	Non-locking push type / Locking type (Tool type)
Rated coil voltage	12, 24 VDC	12, 24 VDC	12, 24 VDC	12, 24 VDC
Power consumption (current value)	DC	1 W	0.5 W	1 W
Electrical entry	Grommet		L-type plug connector	Grommet
	L-type plug connector (with light/surge voltage suppressor)		(with light/surge voltage suppressor)	L-type plug connector (with light/surge voltage suppressor)

Series ZQ

Specifications

Vacuum Pressure Switch

Model		ZQ1-ZSE (ZSE10)	ZQ1-ZSF (ZSE10F)
Rated pressure range		0 to -101 kPa	-100 to 100 kPa
Set pressure range/Display pressure range		10 to -105 kPa	-105 to 105 kPa
Withstand pressure		500 kPa	
Minimum setting unit		0.1 kPa	
Power supply voltage		12 to 24 VDC $\pm 10\%$, Ripple (p-p) 10% or less (with power supply polarity protection)	
Current consumption		40 mA or less	
Switch output		NPN or PNP open collector: 2 outputs (selectable)	
Maximum load current		80 mA	
Maximum applied voltage		28 V (with NPN output)	
Residual voltage		2 V or less (with load current of 80 mA)	
Response time		2.5 ms or less (Response time selections with anti-chattering function: 20, 100, 500, 1000 and 2000 ms)	
Short circuit protection		With short-circuit protection	
Repeatability		$\pm 0.2\%$ F.S. ± 1 digit	
Hysteresis	Hysteresis mode	Variable (0 or above) ^{Note 1)}	
	Window comparator mode		
Analogue output	Voltage output	Output voltage (rated pressure range)	1 to 5 V $\pm 2.5\%$ F.S.
		Linearity	$\pm 1\%$ F.S. or less
		Output impedance	Approx. 1 k Ω
Display system		3 1/2-digit, 7 segment LED 1-colour display (Red)	
Display accuracy		$\pm 2\%$ F.S. ± 1 digit (at ambient temperature of 25 $\pm 3^\circ\text{C}$)	
Operation indicator light		Lights when ON, OUT1: Green, OUT2: Red	
Environmental resistance	Enclosure		IP40
	Ambient humidity range		Operating/Stored: 35 to 85% RH (with no condensation)
	Withstand voltage		1000 VAC for 1 min. between live parts and case
	Insulation resistance		50 M Ω or more (at 500 VDC) between live parts and case
	Vibration resistance		10 to 150 Hz at the smaller of amplitude 1.5 mm or acceleration 20 m/s ² in X, Y, Z directions for 2 hrs. each (De-energized)
Impact resistance		100 m/s ² in X, Y, Z directions 3 times each (De-energized)	
Temperature characteristics		$\pm 2\%$ F.S. (at 25 $^\circ\text{C}$ of ambient temperature range between -5 and 50 $^\circ\text{C}$)	
Lead wires		Oil-resistant cabtire cord Cross section: 0.15 mm ² (AWG26), 5 cores, 2 m, Conductor O.D.: 1.0 mm	

Note 1) If the applied voltage fluctuates around the set-value, the hysteresis must be set to a value more than the fluctuating width, otherwise chattering will occur.

Note 2) For others, refer to ejector specifications on page 4.

Construction

Single unit

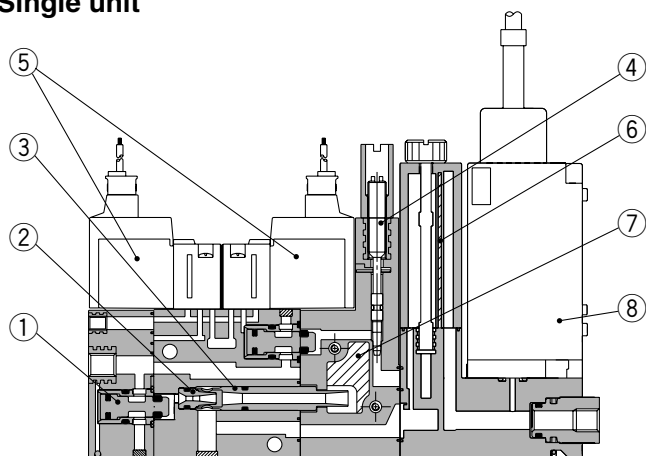

Component Parts

No.	Description	Material
1	Poppet valve assembly	—
2	Nozzle	Aluminum alloy
3	Diffuser	Aluminum alloy
4	Vacuum release flow adjustment needle	Aluminum alloy

Manifold

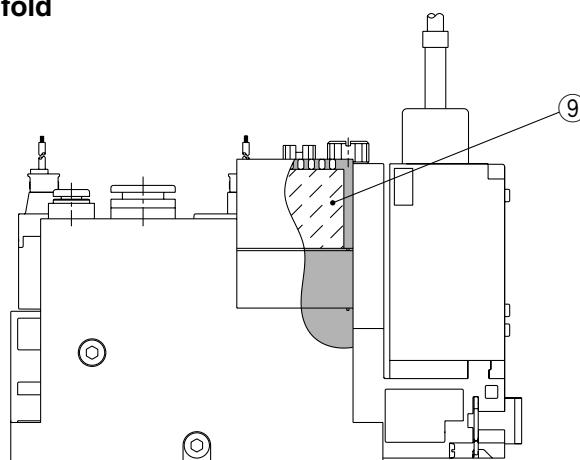

Replacement Parts

No.	Description	Material	Part no.
5	Solenoid valve	—	Refer to page 6.
6	Filter element	PVF	XT534-5-001-AS
7	Sound absorbing material 1 (single unit)	PVF	ZQ-SAE
8	Vacuum pressure switch	—	Refer to page 6
9	Sound absorbing material 2 (manifold)	PVF	ZZQ-SAE

Dimensions

Type K2

ZQ1 □ □ 1U-K2 □ □ □ □ - □ □ □ □ □ □ - □ □ □ - Q

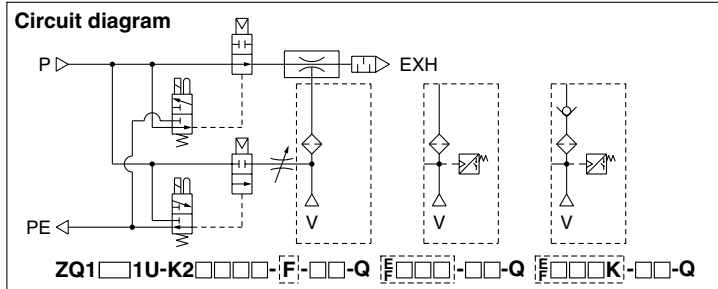
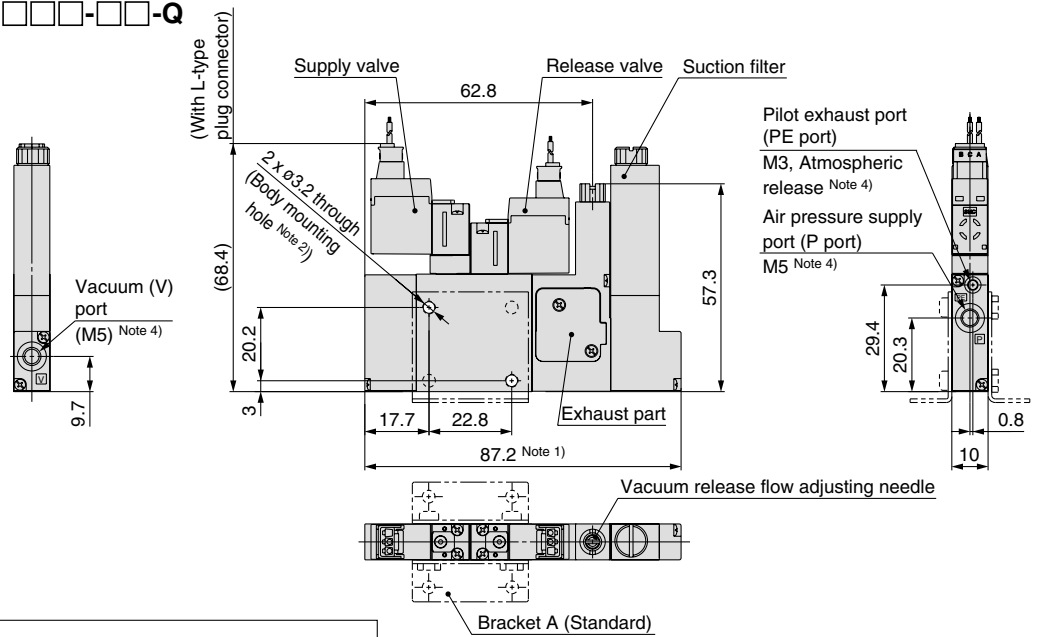

- Note 1) The above dimensions are for ZQ1 □ □ 1U-K2⁵L-F □ □ □ - Q. In case of ZQ1 □ □ 1U-K2 □ □ □ □ - F □ □ □ □ □ □ - □ □ □ - Q, the overall length is 107.5.
- Note 2) The dimensions after bracket A is mounted are the same as those of the K1 type.
- Note 3) When the body is mounted, tighten with a torque of $0.6 \pm 0.06 \text{ N}\cdot\text{m}$. Using excessive torque may cause damage to the body.
- Note 4) The pitches of P, V and PE ports are determined assuming the use of the KJ series one-touch fittings. If used with other fittings, these may cause interference, dependant on their type and size. Please refer to the catalogue to confirm the sizes of the fittings to be used.

Type J2

ZQ1 □ □ 1U-J2 □ □ □ □ - □ □ □ □ □ □ - □ □ □ - Q

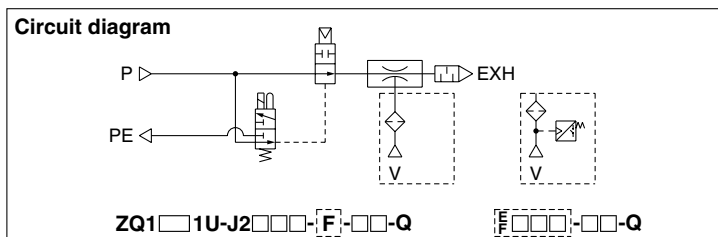
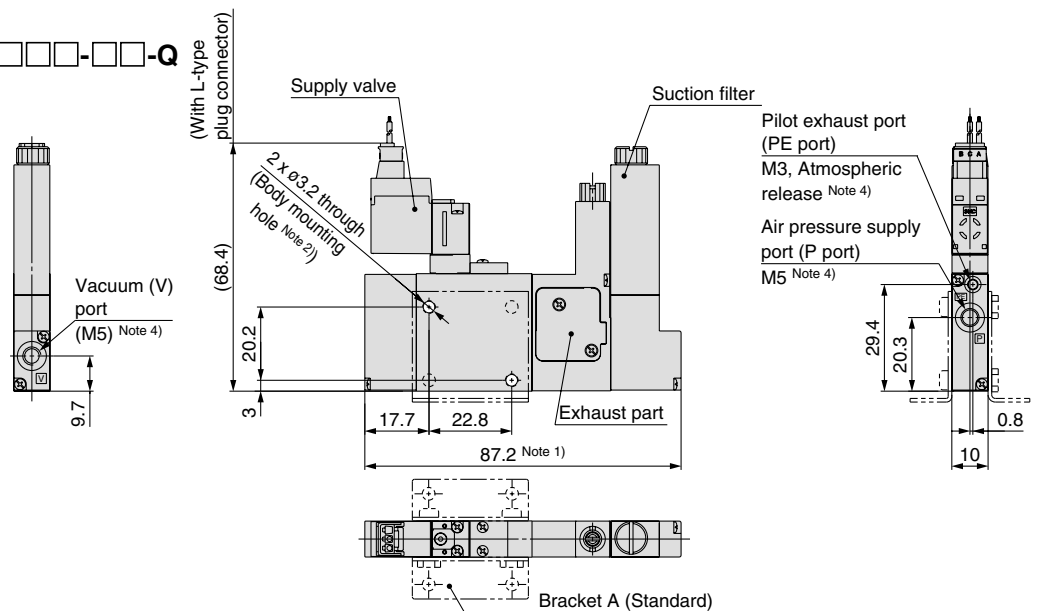

- Note 1) The above dimensions are for ZQ1 □ □ 1U-J2⁵L-F □ □ □ - Q. In case of ZQ1 □ □ 1U-J2 □ □ □ □ - F □ □ □ □ □ □ - □ □ □ - Q, the overall length is 107.5.
- Note 2) The dimensions after bracket A is mounted are the same as those of the K1 type.
- Note 3) When the body is mounted, tighten with a torque of $0.6 \pm 0.06 \text{ N}\cdot\text{m}$. Using excessive torque may cause damage to the body.
- Note 4) The pitches of P, V and PE ports are determined assuming the use of the KJ series one-touch fittings. If used with other fittings, these may cause interference, dependant on their type and size. Please refer to the catalogue to confirm the sizes of the fittings to be used.

Series ZQ

Dimensions

Type Q1, N1

ZQ1 □ □ 1U-Q1⁵ □ □ □ □ □ □ □ □ □ □ -□ □ □ -Q
 ZQ1 □ □ 1U-N1⁶ □ □ □ □ □ □ □ □ □ □ -□ □ □ -Q

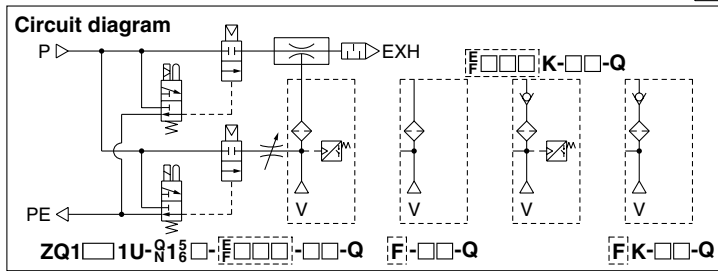
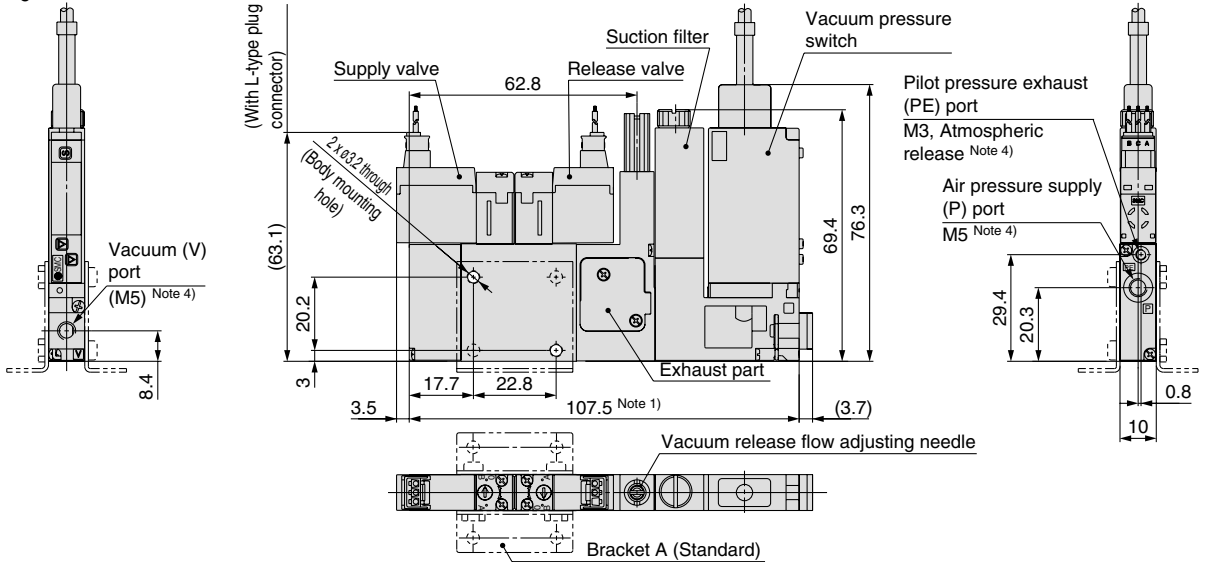

- Note 1) The above dimensions are for ZQ1 □ □ 1U-Q1⁵ □ □ □ □ □ □ □ □ □ □ -□ □ □ -Q. In case of ZQ1 □ □ 1U-N1⁶ □ □ □ □ □ □ □ □ □ □ -□ □ □ -Q, the overall length is 87.2.
- Note 2) The dimensions after bracket A is mounted are the same as those of the K1 type.
- Note 3) When the body is mounted, tighten with a torque of 0.6 ± 0.06 N·m. Using excessive torque may cause damage to the body.
- Note 4) The pitches of P, V and PE ports are determined assuming the use of the KJ series one-touch fittings. If used with other fittings, these may cause interference, dependant on their type and size. Please refer to the catalogue to confirm the sizes of the fittings to be used.

Type Q2, N2

ZQ1 □ □ 1U-Q2 □ □ □ □ □ □ □ □ □ □ -□ □ □ -Q
 ZQ1 □ □ 1U-N2⁵ □ □ □ □ □ □ □ □ □ □ -□ □ □ -Q

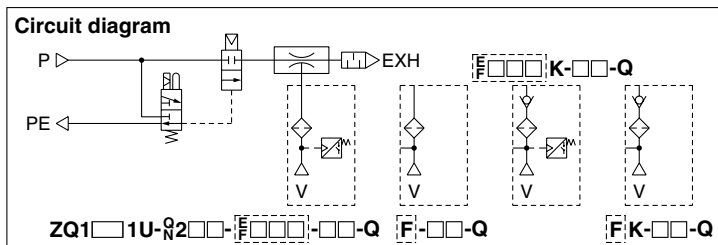
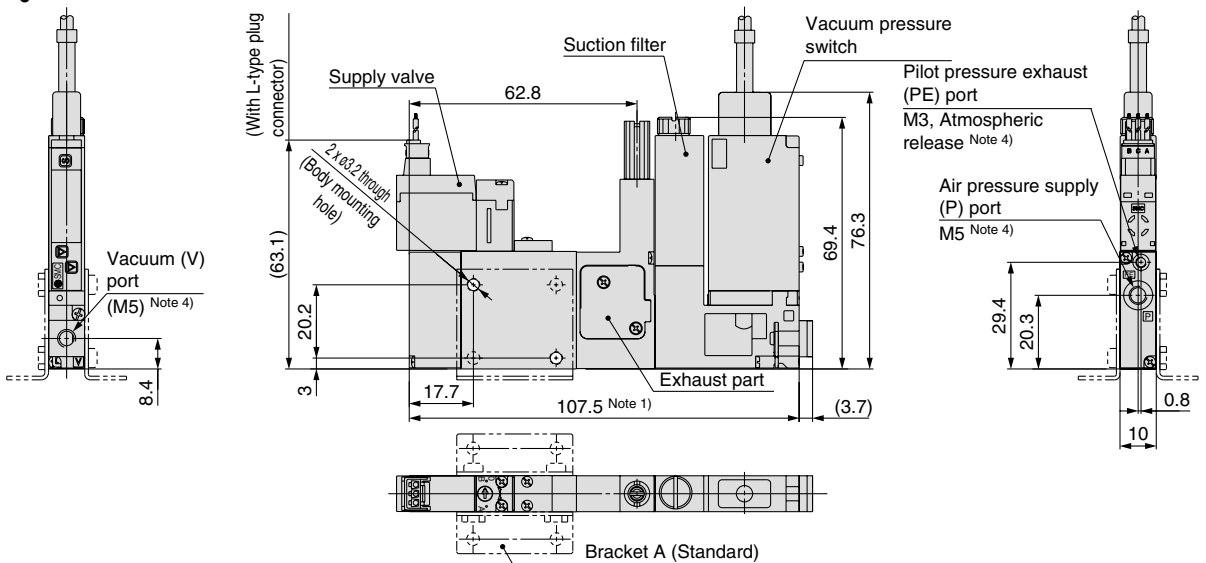

- Note 1) The above dimensions are for ZQ1 □ □ 1U-Q2 □ □ □ □ □ □ □ □ □ □ -□ □ □ -Q. In case of ZQ1 □ □ 1U-N2⁵ □ □ □ □ □ □ □ □ □ □ -□ □ □ -Q, the overall length is 87.2.
- Note 2) The dimensions after bracket A is mounted are the same as those of the K1 type.
- Note 3) When the body is mounted, tighten with a torque of 0.6 ± 0.06 N·m. Using excessive torque may cause damage to the body.
- Note 4) The pitches of P, V and PE ports are determined assuming the use of the KJ series one-touch fittings. If used with other fittings, these may cause interference, dependant on their type and size. Please refer to the catalogue to confirm the sizes of the fittings to be used.

Series ZQ

Dimensions

Manifold type (with PD port)

ZZQ1□-BSC

*ZQ1□3M-□□□□□-□□□□□-□□-□

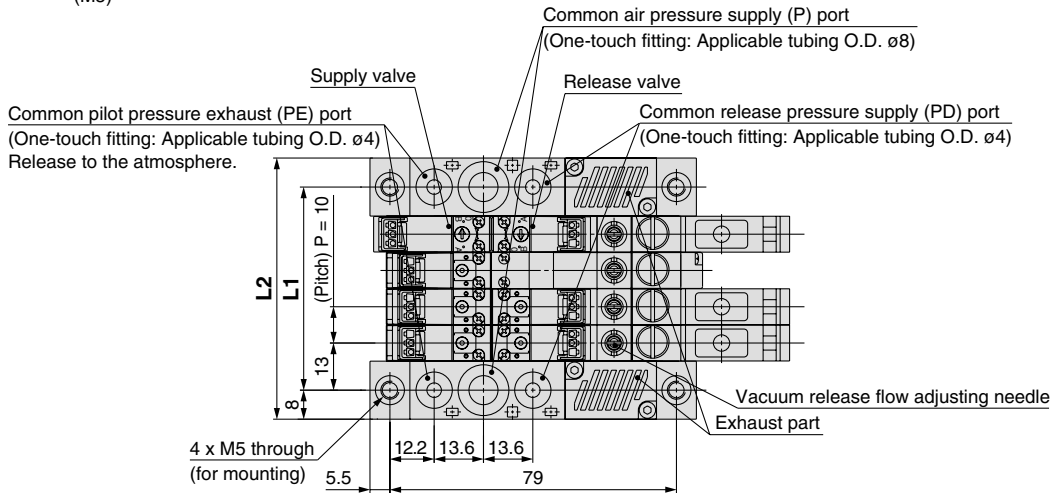
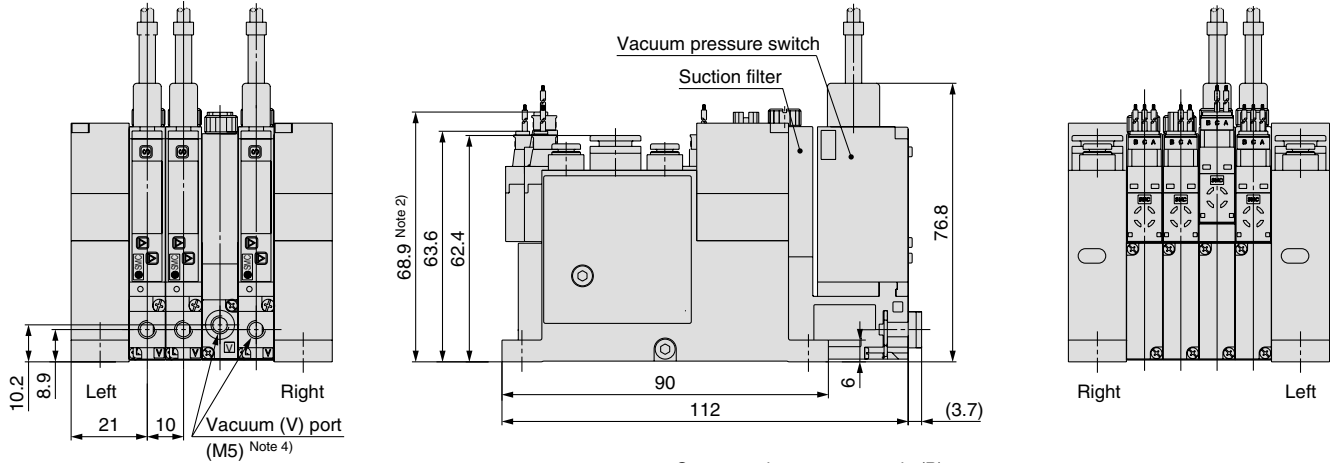

Dimensions

n	1	2	3	4	5	6	7	8
L1	26	36	46	56	66	76	86	96
L2	42	52	62	72	82	92	102	112

Note 1) The above dimensions are for ZZQ104-BSC.

* ZQ1□3M-K1□⁵/₆L-E□G-00-Q.

* ZQ1□3M-K2□⁵/₆L-E□G-00-Q.

* ZQ1□3M-J1□⁵/₆L-F□00-Q.

* ZQ1□3M-Q1□⁵/₆L-E□G-00-Q.

* In case of ZQ1□3M-□□□□□-F□00-Q, the overall length is 91.7.

* In case of ZQ1□3M-□□□□□-E□G-00-Q, the overall length is 112.

Note 2) * The above dimensions are for ZQ1□3M-⁵/₆□□□□□-□□-□.

Note 3) When the body is mounted, tighten with a torque of 0.6 ± 0.06 N·m. Using excessive torque may cause damage to the body.

Note 4) The pitches of V ports are determined assuming the use of the KJ series one-touch fittings. If used with other fittings, these may cause interference, dependant on their type and size. Please refer to the catalogue to confirm the sizes of the fittings to be used.

Note 5) When the release valve is not used, design the circuit for vacuum release separately in order to release a workpiece.

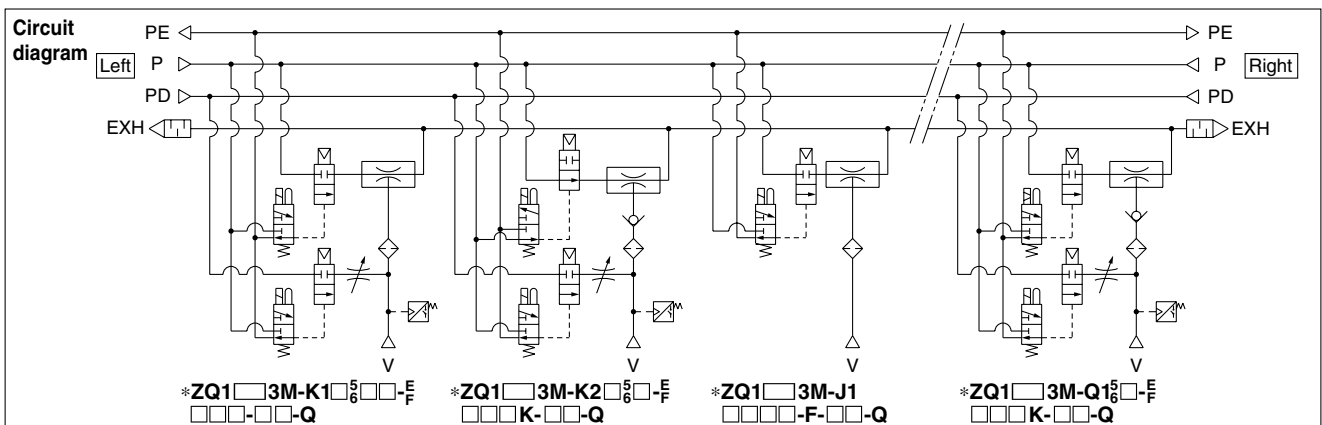

Dimensions

Fittings / Fitting type filter dimensions after installation

V port

<With vacuum pressure switch>

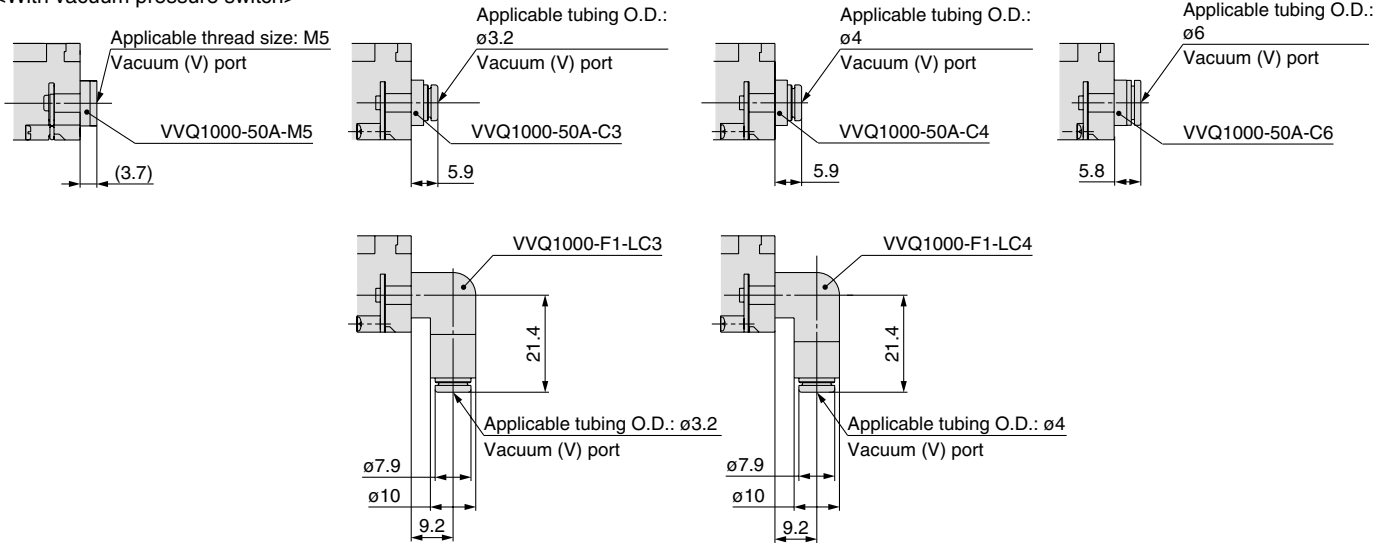

V port

<Suction filter only>

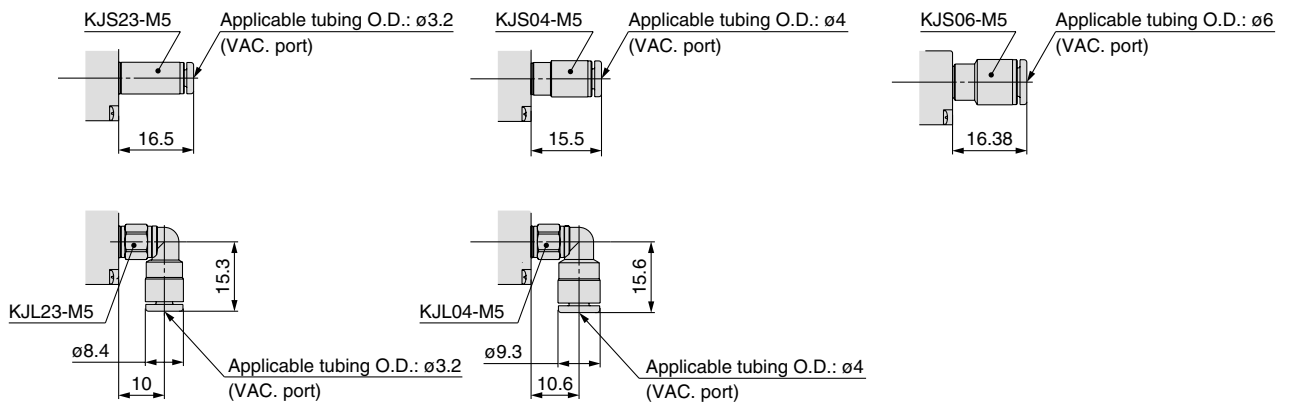

P port (for ejector)

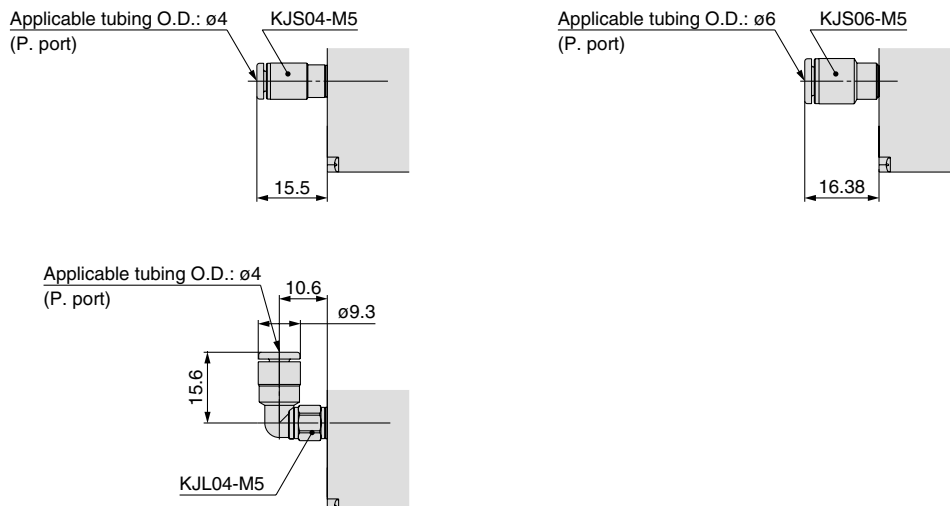



Please contact SMC for detailed dimensions, specifications, and lead times.

1 Port Exhaust Specifications

Manifold ZZQ1 Stations* - B2B - X125

● Port exhaust specifications

Exhaust port is changed for "Port Exhaust Specifications."

Dimensions

Manifold type (without PD port)

ZZQ1□-B2B-X125

*ZQ1□3M-□□□□□-□□□□□-□□-□

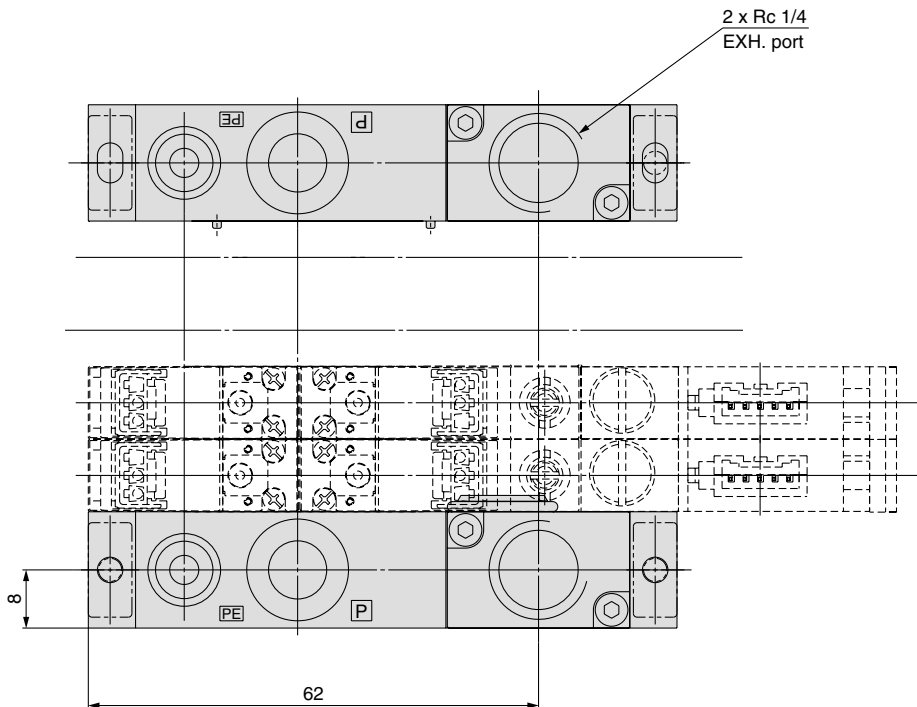

Manifold Exploded View

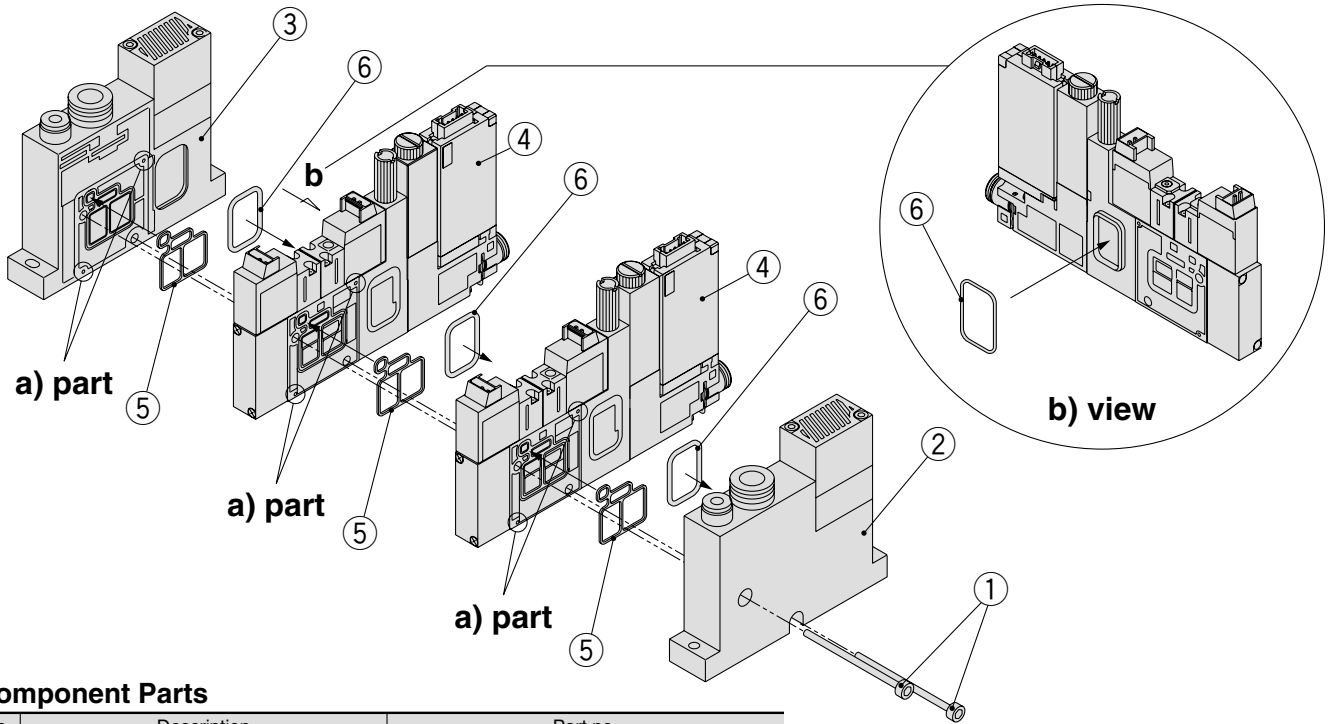

Component Parts

No.	Description	Part no.
1	Hexagon socket head cap screw	Refer to "How to Order" below.-Q
2	End block L	Refer to "Table (1)" (including 1 pc. of ⑥).
3	End block R	Refer to "Table (1)" (including 1 pc. of ⑤).
4	Ejector assembly	ZQ1□□3M-□□□□□□-□□□□-□□-□ Note 1
5	Ejector body gasket for manifold	ZQ-3-005-10AS Note 2
6	Exhaust block gasket	ZQ-3-009-10AS Note 2

Note 1) Refer to pages 1 and 2 for detailed description of "How to Order".
 Note 2) 10 pcs. are included in one set.

Table (1)

Description	With PD port	Without PD port
End block L	ZQ1L-2-BSB-AS	ZQ1L-1-BSB-AS
End block R	ZQ1R-2-BSB-AS	ZQ1R-1-BSB-AS

Working Procedure

Disassembly

Loosen and remove the clamp rod ①.

Assembly

1. Install the ejector body gasket for manifold ⑤ into the gasket groove of each ejector assembly ④. Install the exhaust block gasket ⑥ around the projected part.
2. Install the exhaust block gasket ⑥ around the projected part of the end block L ②.
3. Install the ejector body gasket for manifold ⑤ into the gasket groove of the end block R ③.
4. Align the ejector assemblies ④, end block (L) ②, and end block (R) ③ using positioning pins (at the two "a" positions) and fasten with clamp rods ① (2 pcs.) (with a tightening torque of $0.6 \text{ N}\cdot\text{m} \pm 0.06 \text{ N}\cdot\text{m}$).

Replacement of V Port Fittings (With vacuum pressure switch)

V port fittings are cassette style for easy replacement. The fittings are blocked by a clip. Remove the clip with a flat blade screwdriver, etc. to replace the fittings. When mounting the fittings, after inserting the fitting assembly until it stops, then put the clip into the prescribed position completely.

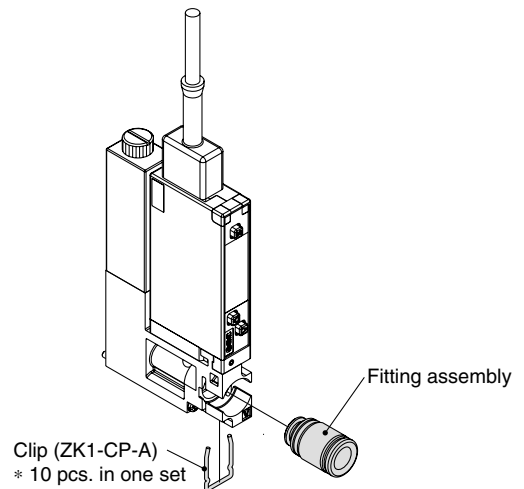

How to Order Hexagon Socket Head Cap Screw

ZQ-STB 05

• Number of stations

05	1 station
06	2 stations
⋮	⋮
8	8 stations

Note) 2 pcs. are included in one set.

Applicable tubing O.D.	Straight	Elbow
Applicable tubing O.D. $\phi 3.2$	VVQ1000-50A-C3	VVQ1000-F1-LC3
Applicable tubing O.D. $\phi 4$	VVQ1000-50A-C4	VVQ1000-F1-LC4
Applicable tubing O.D. $\phi 6$	VVQ1000-50A-C6	—
M5 female thread	VVQ1000-50A-M5	—

Space Saving Vacuum Pump System

Series ZQ

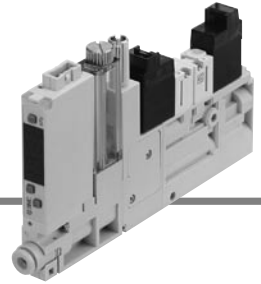

How to Order

Vacuum Pump Unit

ZQ1000 **U** - **K1** **5** **L** - **EA** **G** - **Q**

①
②
③
④
⑤
⑥
⑦
⑧
⑨
⑩
⑪

① Body type

U	For single unit
M	For manifold

② Solenoid valve combination

Symbol	Supply valve	Vacuum release valve
K1	Normally closed	Normally closed
K2 <small>Note 1)</small>	Normally open	Normally closed
J1	Normally closed	None
J2 <small>Note 1)</small>	Normally open	None
Q1	Latching positive common	Normally closed
Q2	Latching positive common	None
N1	Latching negative common	Normally closed
N2	Latching negative common	None

⚠ The air in the adsorption section of this product is not released to the atmosphere at the vacuum suspension state.
 As for K1, K2, Q1 and N1, use the vacuum release valve when a workpiece is detached.
 Concerning J1, J2, Q2 and N2, devise the circuit for the vacuum release additionally when a workpiece is detached.

Note 1) In cases when K2 or J2 (supply valve normally open) is selected for the solenoid valve combination, when vacuum is stopped for long periods of time (10 minutes or more), do not continue to energize the supply valve, and shut off the air supply.

③ Pilot valve (Refer to Table (1).)

—	Standard (DC: 1 W) <small>Note 2)</small>
Y	DC low wattage type (0.5 W) <small>Note 2)</small>

Note 2) Avoid energizing the solenoid valve for long periods of time. (Refer to Specific Product Precautions 1; Caution on Design and Selection.)

④ Solenoid valve rated voltage

5	24 VDC
6	12 VDC

⑤ Electrical entry

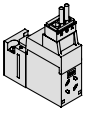
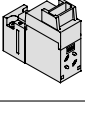
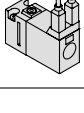
L	L-type plug connector, with 0.3 m lead wire, with light/surge voltage suppressor	
LO	L-type plug connector, without connector, with light/surge voltage suppressor	
G	Grommet, with 0.3 m lead wire	

⑥ Manual override Note 3)

—	Non-locking push type Latching type: Push-locking type
B	Locking type (Q1/Q2/N1/N2: Not applicable)

Note 3) Latching type supply valve: Available in "Nil" only.
In this case, the supply valve and release valve come with a push-locking type.

⑦ Vacuum pressure switch suction filter Note 4)

EA	0 to -101 kPa/NPN open collector 2 outputs, with suction filter
EB	0 to -101 kPa/PNP open collector 2 outputs, with suction filter
EC	0 to -101 kPa/NPN open collector 1 output + analogue voltage, with suction filter
EE	0 to -101 kPa/PNP open collector 1 output + analogue voltage, with suction filter
FA	100 to -100 kPa/NPN open collector 2 outputs, with suction filter
FB	100 to -100 kPa/PNP open collector 2 outputs, with suction filter
FC	100 to -100 kPa/NPN open collector 1 output + analogue voltage, with suction filter
FE	100 to -100 kPa/PNP open collector 1 output + analogue voltage, with suction filter
F	Suction filter only

Note 4) The filter included in this product is of a simple type, and will become clogged quickly in environments with high quantities of dust or particulates. Please make additional use of an air suction filter of the ZFA, ZFB or ZFC series.

⚠ Warning

The filter case of this suction filter is made of nylon. Contact with alcohol or similar chemicals may cause it to be damaged. Also, do not use the filter when these chemicals are present in the atmosphere.

⑧ Vacuum pressure switch unit specifications

—	With unit switching function <small>Note 5)</small>
M	Fixed SI unit <small>Note 6)</small>
P	With unit switching function <small>Note 5)</small> (Initial value psi)

Note 5) Under the New Measurement Law, sales of switches with the unit switching function are not allowed for use in Japan.

Note 6) Fixed unit: kPa

⑨ Vacuum pressure switch lead wire specifications

—	Without connector
G	Lead wire with connector (Lead wire length 2 m) With connector cover

⑩ Fitting (P port) Note 7)

Symbol	Applicable tubing O.D.	Part no.	
		Vacuum pressure switch	Filter only
0	Without fitting (M5 x 0.8)	VVQ1000-50A-M5	—
1	ø3.2 (Straight)	VVQ1000-50A-C3	KJS23-M5
2	ø4 (Straight)	VVQ1000-50A-C4	KJS04-M5
3	ø6 (Straight)	VVQ1000-50A-C6	KJS06-M5
4	ø3.2 (Elbow)	VVQ1000-F1-LC3	KJL23-M5
5	ø4 (Elbow)	VVQ1000-F1-LC4	KJL04-M5

⑪ Fitting (PS / PV port) Note 7)

Symbol	Applicable tubing O.D.	Part no.	Object spec.
—	Without port	—	Manifold
0	Without fitting (M5 x 0.8)	—	Single unit
2	ø4 (Straight)	KJS04-M5	
3	ø6 (Straight)	KJS06-M5	
5	ø4 (Elbow)	KJL04-M5	

Note 7) For filter only (Without vacuum pressure switch)

When neither V port fitting nor PS/PV port fitting are needed, enter nothing or -00 in the dotted line above "How to Order".

How to Order

Manifold Ordering Example

Manifold **ZZQ1 08** - □ O □

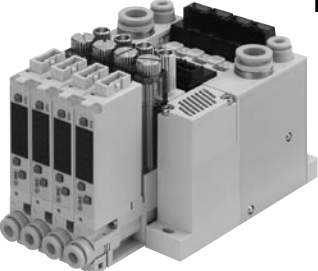

Number of stations

01	1 station
02	2 stations
⋮	⋮
08	8 stations

Vacuum pressure supply port (PV port) Port location (Refer to Table (1).)

L	Left side
R	Right side

Table (1) Air Pressure Supply Port Location on the Manifold

PD port	Manifold Port location	Left			Right		
		PS	PV	PD	PS	PV	PD
B	L (Left side)	—	●	—	● (Note)	—	—
	R (Right side)	● (Note)	—	—	—	●	—
C	L (Left side)	—	●	●	●	—	●
	R (Right side)	●	—	●	—	●	●

Note) The position of each port is shown as right and left sides viewed from the front side of the vacuum port.
Release pressure is commonly supplied from the PS port.
* PS: Pilot pressure supply port, PV: Vacuum pressure supply port, PD: Release pressure supply port

Release pressure supply port (PD port)

B	None (Release pressure is supplied from the PS port.)
C	Provided (Air can be alternatively supplied from the PS port.)

ZZQ108-R0B → 1 pc.
 *ZQ1000M-K15L-EAG-Q
 → 4 pcs. (Stations 1 to 4)
 *ZQ1000M-K1Y5L-EAG-Q
 → 4 pcs. (Stations 5 to 8)

Note) By viewing the front side of vacuum port (V), stations are counted starting from station 1 on the left side.

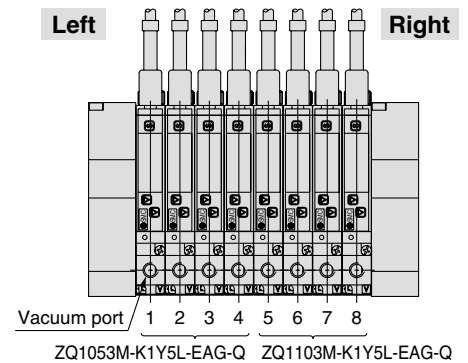

Specifications

Common

Switching method for vacuum/release valve	Piloted	
Cv factor	0.11	
Supply pressure range	Vacuum pressure supply port (PV)	0 to -101.3 kPa
	Pilot/Pressure port (PS)	0.3 to 0.5 MPa (Normally open: 0.3 to 0.45 MPa)
	Supply pressure port for vacuum release (PD)	0.3 to 0.5 MPa (Normally open: 0.3 to 0.45 MPa), and also PD pressure ≤ PS pressure
Operating temperature range	5 to 50°C	
Fluid	Air / Inert gas	

Weight

Single unit	With suction filter ^{Note 1)}	95 g
	With vacuum pressure switch and suction filter ^{Note 2)}	109 g
	End plate assembly for manifold	122 g

Note 1) Including a 0.3 m connector for supply valve and vacuum release valve.

Note 2) Including a 0.3 m connector for supply valve and vacuum release valve and a 2 m connector for vacuum pressure switch.

◎ Calculation of weight for the manifold type
 (Single unit weight) x (Number of stations) +
 (Weight of end plate assembly for manifold)

Example) Vacuum pressure switch + 8 stations with suction filter
 109 g x 8 + 122 g = 994 g

Supply Valve / Vacuum Release Valve

Item	Type	Normally closed		Latching type	Normally open
		Standard (1 W)	Low wattage type (0.5 W)		
Model (Refer to "How to Order" for solenoid valves on page 19.)		VQ110-□	VQ110Y-□	VQ110 _N -□	ZQ1-VQ120-□
Manual override		Non-locking push type / Locking type (Tool type)		Push-locking type	Non-locking push type / Locking type (Tool type)
Rated coil voltage		12, 24 VDC	12, 24 VDC	12, 24 VDC	12, 24 VDC
Power consumption (current value)	DC	1 W	0.5 W	1 W	
Electrical entry		Grommet		L-type plug connector	Grommet
		L-type plug connector (with light/surge voltage suppressor)		(with light/surge voltage suppressor)	(with light/surge voltage suppressor)

Specifications

Vacuum Pressure Switch

Model		ZQ1-ZSE (ZSE10)	ZQ1-ZSF (ZSE10F)
Rated pressure range		0 to -101 kPa	-100 to 100 kPa
Set pressure range/Display pressure range		10 to -105 kPa	-105 to 105 kPa
Withstand pressure		500 kPa	
Minimum setting unit		0.1 kPa	
Power supply voltage		12 to 24 VDC $\pm 10\%$, Ripple (p-p) 10% or less (with power supply polarity protection)	
Current consumption		40 mA or less	
Switch output		NPN or PNP open collector: 2 outputs (selectable)	
	Maximum load current	80 mA	
	Maximum applied voltage	28 V (with NPN output)	
	Residual voltage	2 V or less (with load current of 80 mA)	
	Response time	2.5 ms or less (Response time selections with anti-chattering function: 20, 100, 500, 1000 and 2000 ms)	
	Short circuit protection	With short-circuit protection	
Repeatability		$\pm 0.2\%$ F.S. ± 1 digit	
Hysteresis	Hysteresis mode	Variable (0 or above) ^{Note 1)}	
	Window comparator mode		
Analogue output	Voltage output	Output voltage (rated pressure range)	1 to 5 V $\pm 2.5\%$ F.S.
		Linearity	$\pm 1\%$ F.S. or less
		Output impedance	Approx. 1 k Ω
Display system		3 1/2-digit, 7 segment LED 1-colour display (Red)	
Display accuracy		$\pm 2\%$ F.S. ± 1 digit (at ambient temperature of $25 \pm 3^\circ\text{C}$)	
Operation indicator light		Lights when ON, OUT1: Green, OUT2: Red	
Environmental resistance	Enclosure		IP40
	Ambient humidity range		Operating/Stored: 35 to 85% RH (with no condensation)
	Withstand voltage		1000 VAC for 1 min. between live parts and case
	Insulation resistance		50 M Ω or more (at 500 VDC) between live parts and case
	Vibration resistance		10 to 150 Hz at the smaller of amplitude 1.5 mm or acceleration 20 m/s ² in X, Y, Z directions for 2 hrs. each (De-energized)
Impact resistance		100 m/s ² in X, Y, Z directions 3 times each (De-energized)	
Temperature characteristics		$\pm 2\%$ F.S. (at 25°C of ambient temperature range between -5 and 50°C)	
Lead wires		Oil-resistant cabtire cord Cross section: 0.15 mm ² (AWG26), 5 cores, Conductor O.D.: 1.0 mm	

Note 1) If the applied voltage fluctuates around the set-value, the hysteresis must be set to a value more than the fluctuating width, otherwise chattering will occur.
 Note 2) For others, refer to ejector specifications on page 17.

Construction

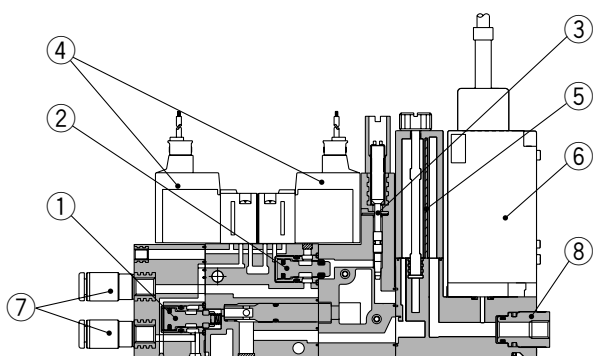

Component Parts

No.	Description	Material
1	Poppet valve assembly for supply valve	—
2	Poppet valve assembly for vacuum release valve	—
3	Vacuum release flow adjusting needle	Aluminum alloy

Replacement Parts

No.	Description	Material	Part no.
4	Solenoid valve	—	Refer to page 19.
5	Filter element	PVF	XT534-5-001-AS
6	Vacuum pressure switch	—	Refer to page 19.
7	Fitting	—	Refer to "How to Order" on page 19.

How to Order

Solenoid Valve

Actuation

- 1 Normally closed
- 2 Normally open

Pilot valve

—	Standard (DC: 1 W)
Y	Low wattage type (0.5 W)
L	Latching positive common
N	Latching negative common

Solenoid valve rated voltage

5	24 VDC
6	12 VDC

Manual override Note)

—	Non-locking push type
B	Latching type: Push-locking type
	Locking type

Note) Latching type: Available in "—" only

Electrical entry Note)

L	L-type plug connector, with 0.3 m lead wire	
LO	L-type plug connector, without connector	
G	Grommet, with 0.3 m lead wire	

Note) Mounting screws are attached.

Connector assembly part no.

- Single AXT661-14A-
- DC positive common • Latching AXT661-13A-
- DC negative common • Latching AXT661-13AN-
- Connector, socket (3 pcs) only AXT661-12A

Lead wire length

—	300 mm
6	600 mm
10	1000 mm
20	2000 mm
30	3000 mm

Lead wire length of the plug connector

The lead wire length for a valve with a lead wire is 300 mm. When in need of a valve with a lead wire longer than 600 mm, place an order for a valve without a connector and connector assembly.

Ordering Examples:
 VQ1 1 0 [] - 5 L [] - Q
 ZQ1-VQ1 2 0 [] - 5 L [] - Q

Vacuum Pressure Switch

Vacuum pressure switch specifications

EA	0 to -101 kPa/NPN open collector 2 outputs, with suction filter
EB	0 to -101 kPa/PNP open collector 2 outputs, with suction filter
EC	0 to -101 kPa/NPN open collector 1 output + analogue voltage, with suction filter
EE	0 to -101 kPa/PNP open collector 1 output + analogue voltage, with suction filter
FA	100 to -100 kPa/NPN open collector 2 outputs, with suction filter
FB	100 to -100 kPa/PNP open collector 2 outputs, with suction filter
FC	100 to -100 kPa/NPN open collector 1 output + analogue voltage, with suction filter
FE	100 to -100 kPa/PNP open collector 1 output + analogue voltage, with suction filter

Vacuum pressure switch unit specifications

—	With unit switching function <small>Note 1)</small>
M	Fixed SI unit <small>Note 2)</small>
P	With unit switching function <small>Note 1)</small> (Initial value psi)

Note 1) Under the New Measurement Law, sales of switches with the unit switching function are not allowed for use in Japan.
Note 2) Fixed unit: kPa

Vacuum pressure switch lead wire specifications

—	Without connector
G	Lead wire with connector (lead wire length 2 m) With connector cover

Check valve Note 3)

—	None
K	With check valve

Note 3) The check valve has a function to prevent the exhaust air from the silencer overflowing to the vacuum port side when a manifold is used, but it is incapable of completely preventing overflow. During usage, please inspect thoroughly with actual machine. Also, in order to completely prevent the overflow of exhaust air, leave plenty of space between the check valve unit and adjacent ejector to avoid interference from the ejector's exhaust unit.

Warning

- Cannot be used for vacuum retention.
- Use a vacuum release valve. (Without a vacuum release valve, the workpiece may not be released.)

Fitting (V port)

Symbol	Applicable tubing O.D.
0	Without fitting (M5 x 0.8)
1	ø3.2 (Straight)
2	ø4 (Straight)
3	ø6 (Straight)
4	ø3.2 (Elbow)
5	ø4 (Elbow)

Ordering Example: ZQ1-ZS [] [] [] [] - [] - A

* The vacuum pressure switch mounted on this product is equivalent to our SMC product, the ZSE10 series compact digital pressure switch.

Pressure switch correspondence table

Vacuum Pump System Series ZQ	Vacuum Pressure Switch for ZQ	Digital Pressure Switch Series ZSE10
ZQ1 [] [] - [] [] [] [] - [] [] [] - [] [] - Q	ZQ1-ZS [] [] [] [] - [] [] [] - A	ZSE10 [] [] [] [] - [] [] [] []

Rated pressure range/Output specifications correspondence table

Vacuum pressure switch for ZQ	Series ZSE10	Specification
ZQ1-ZSEA [] [] [] [] - [] [] - A	ZSE10- [] - A- [] [] [] []	0 to -101 kPa/NPN open collector 2 outputs
ZQ1-ZSEB [] [] [] [] - [] [] - A	ZSE10- [] - B- [] [] [] []	0 to -101 kPa/PNP open collector 2 outputs
ZQ1-ZSEC [] [] [] [] - [] [] - A	ZSE10- [] - C- [] [] [] []	0 to -101 kPa/NPN open collector 1 output + analogue voltage
ZQ1-ZSEE [] [] [] [] - [] [] - A	ZSE10- [] - E- [] [] [] []	0 to -101 kPa/PNP open collector 1 output + analogue voltage
ZQ1-ZSFA [] [] [] [] - [] [] - A	ZSE10F- [] - A- [] [] [] []	100 to -100 kPa/NPN open collector 2 outputs
ZQ1-ZSFB [] [] [] [] - [] [] - A	ZSE10F- [] - B- [] [] [] []	100 to -100 kPa/PNP open collector 2 outputs
ZQ1-ZSFC [] [] [] [] - [] [] - A	ZSE10F- [] - C- [] [] [] []	100 to -100 kPa/NPN open collector 1 output + analogue voltage
ZQ1-ZSFE [] [] [] [] - [] [] - A	ZSE10F- [] - E- [] [] [] []	100 to -100 kPa/PNP open collector 1 output + analogue voltage

For details regarding vacuum pressure switches, refer to the catalogue, "Series ZSE10" (CAT.ES100-75).

Series ZQ

Dimensions

Manifold type (without PD port)

ZZQ1□□-□OB

*ZQ1000M-□□□□□-□□□□□-□□□-□Q

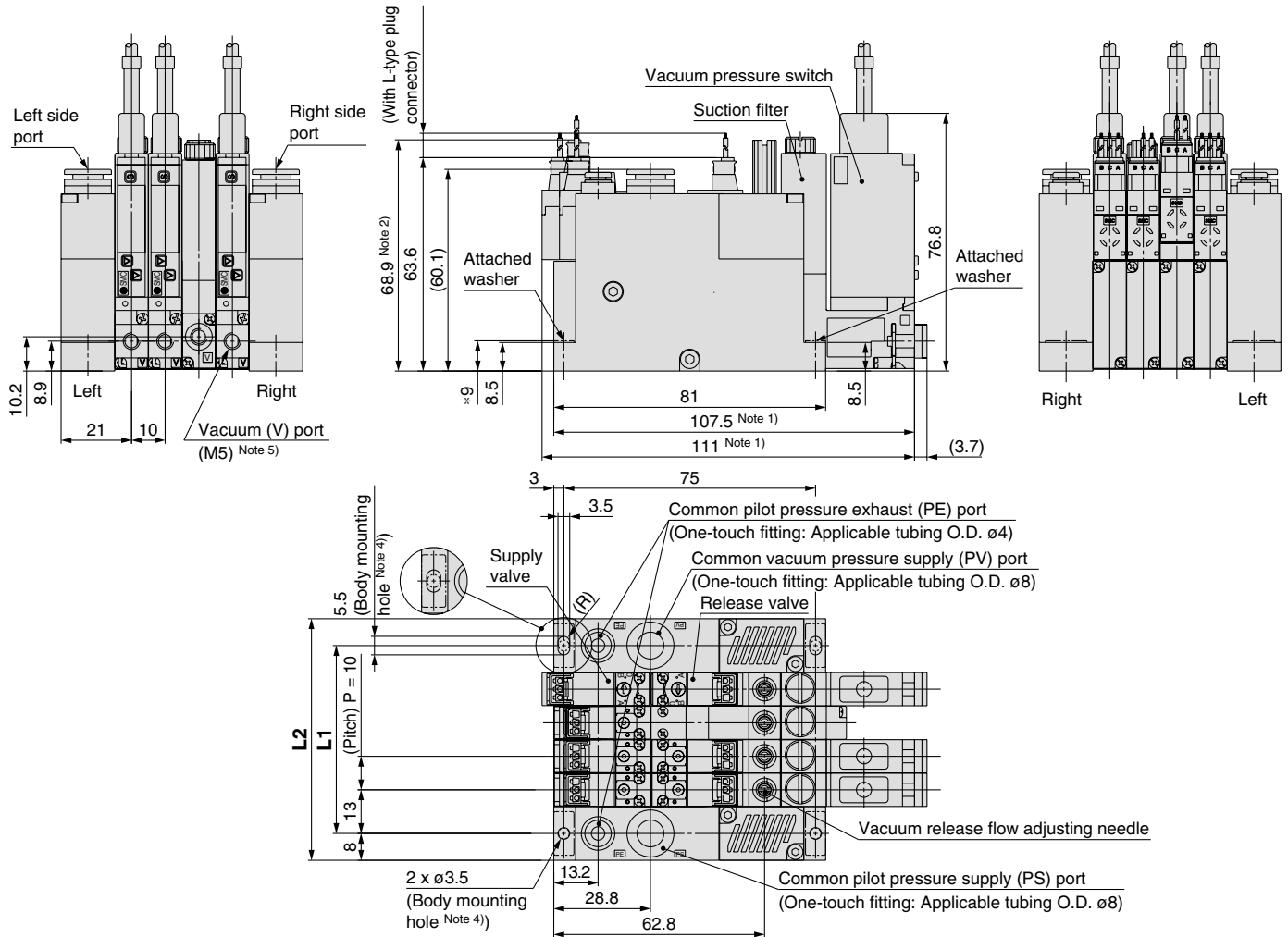

Dimensions

n	1	2	3	4	5	6	7	8
L1	26	36	46	56	66	76	86	96
L2	42	52	62	72	82	92	102	112

Note 1) The above dimensions are for ZZQ104-ROB.

* ZQ1000M-K1□□□□□-E□□□□□G-00-Q.

* ZQ1000M-K2□□□□□-E□□□□□G-00-Q.

* ZQ1000M-J1□□□□□-E□□□□□F-00-Q.

* ZQ1000M-Q1□□□□□-E□□□□□G-00-Q.

* In case of ZQ1000M-□□□□□-E□□□□□-F-00-Q, the overall length is 87.2.

* In case of ZQ1000M-□□□□□-E□□□□□-F-00-Q, the overall length is 90.7.

* In case of ZQ1000M-□□□□□-E□□□□□-F-00-Q, the overall length is 107.5.

* In case of ZQ1000M-□□□□□-E□□□□□-G-00-Q, the overall length is 111.

Note 2) * The above dimensions are for ZQ1000M-□□□□□-E□□□□□-□□□□□-□□□□□-□Q.

Note 3) Dimensions marked with "*" are those after the attached washer is mounted.

Note 4) When the body is mounted, tighten with a torque of $0.6 \pm 0.06 \text{ N}\cdot\text{m}$. Using excessive torque may cause damage to the body.

Note 5) The pitches of V ports are determined assuming the use of the KJ series one-touch fittings. If used with other fittings, these may cause interference, dependant on their type and size. Please refer to the catalogue to confirm the sizes of the fittings to be used.

Note 6) When the release valve is not used, design the circuit for vacuum release separately in order to release a workpiece.

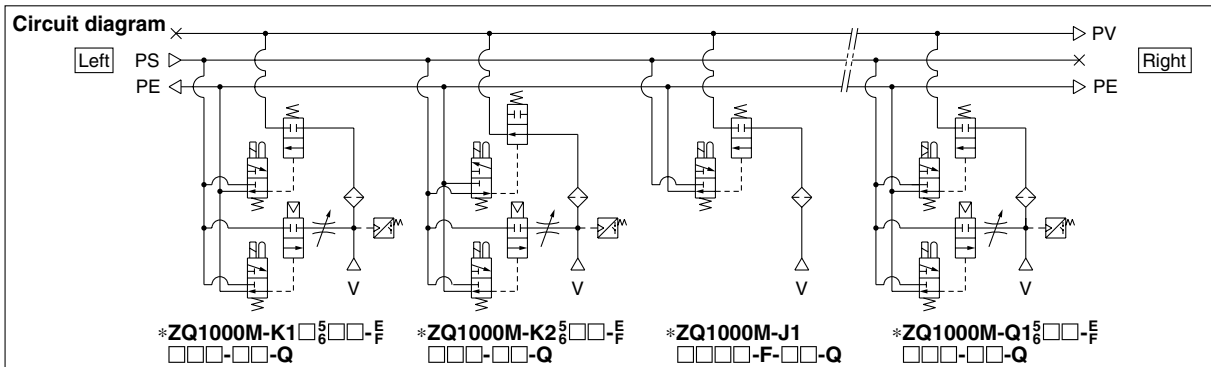

Dimensions

Fittings / Fitting type filter dimensions after installation

V port

<With vacuum pressure switch>

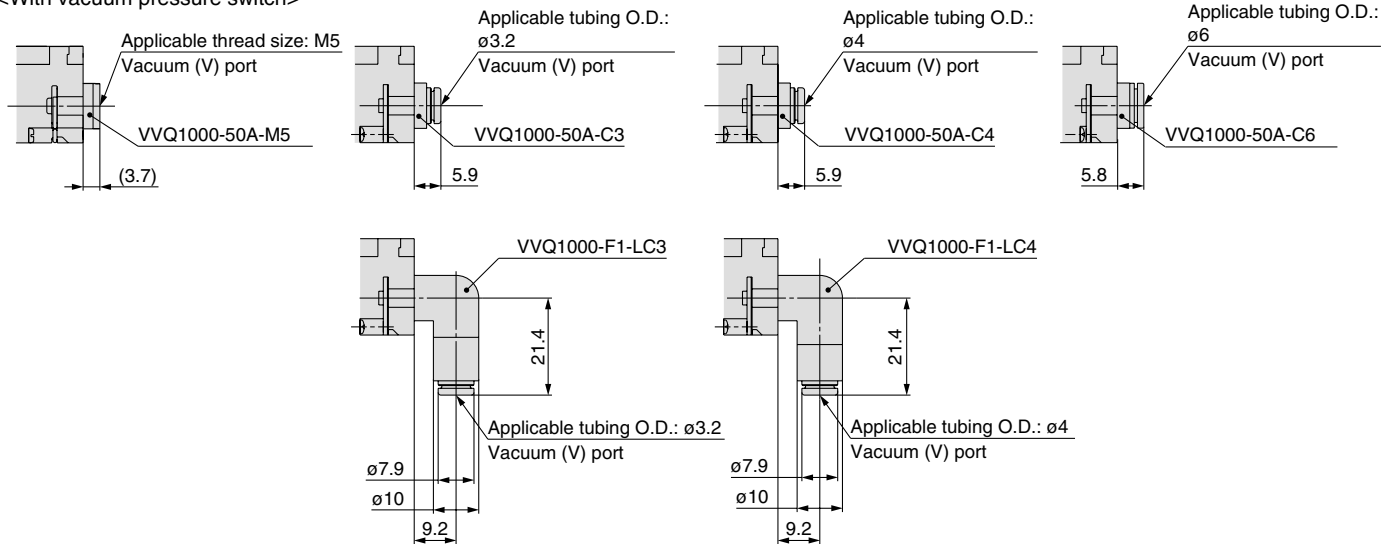

V port

<Suction filter only>

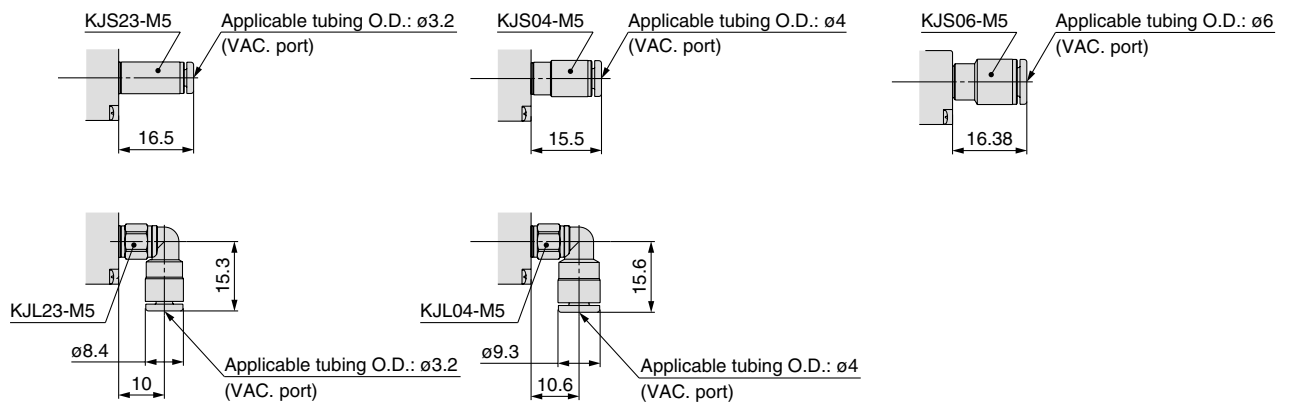

PS / PV port (for pump)

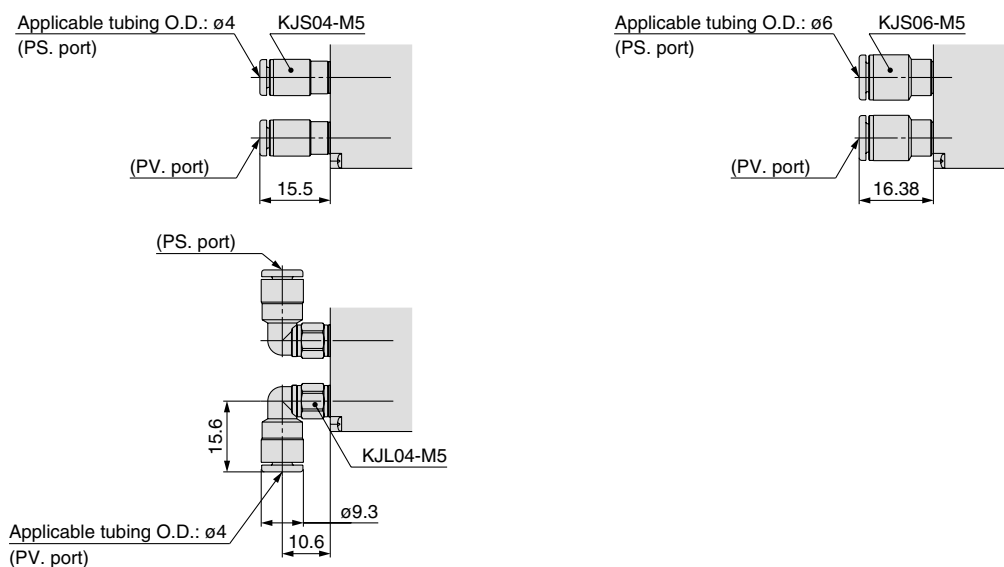



Series ZQ

Specific Product Precautions

Be sure to read before handling.

Refer to “Handling Precautions for SMC Products” (M-E03-3) for Vacuum Equipment Precautions.

Design and Selection

Warning

1. Avoid energizing the solenoid valve for long periods of time.

If a solenoid valve is energized for a long period of time, the coil will get hot and the performance may be reduced. Additionally, the peripheral equipment in close proximity may also be badly affected. Use a low wattage solenoid valve when the solenoid valve is energized continuously or when the duration of the energization is longer than the non-energized period each day. Periods of energization can be shortened by using a normally opened or latching type solenoid valve. But, do not energize the coil on both A and B sides simultaneously when using the latching type.

Continuous energization of the solenoid valve should be less than 10 minutes in duration and the energization period should be shorter than the non-energized period. Take measures for any heat radiation so that the temperature is within the range of solenoid valve specifications when the solenoid valve is mounted on the control panel. Please pay special attention to any temperature increases when a manifold type with 3 stations or more is energized continuously or when three individual units are placed in close proximity.

2. Use the vacuum equipment within the operating supply pressure range.

When the operating with a lower supply pressure, the vacuum performance will be reduced and the poppet valve will cause malfunction.

Never use the vacuum equipment more than the operating supply pressure range as this may cause damage to the product resulting in potentially dangerous operation.

3. Suspension of operation for long periods of time

Please use caution — as detailed below — when the vacuum equipment is turned off for periods in excess of 6 hours.

- Be sure to turn off the pressure supply to the vacuum equipment.

Please observe this precautions as the supply pressure will be applied for a extra period of time due to the line pressure increase and may result in damage to the vacuum equipment.

- Be sure to turn off the power supply to the solenoid valve and the pressure switch.

Please observe this precautions as any heat generated due to the length of energization time may seriously affect the vacuum equipment and peripheral equipment resulting in potentially dangerous operation.

4. Check valve

The check valve has a function to prevent the exhaust air from the silencer overflowing to the vacuum port side when a manifold is used. However, depending on usage conditions, it does not always suppress air overflow to the desired extent. During usage, please inspect thoroughly with actual machine. Also, no guarantee is therefore provided when used for any other purposes. It is especially dangerous if used for the purpose of workpiece drop prevention in the case of operator blackout. Therefore, please take additional measures for providing drop prevention, such as providing a guide.

5. Exhaust port (EXH port) on the vacuum ejector

Please check the exhaust port (EXH port) on the vacuum ejector, so that any exhaust resistance will not be increased due to insulating materials or restrictions in the piping. The exhaust resistance may reduce the ejector's performance. Additionally, never use this product in an application where the exhaust port is blocked when detaching a workpiece. This misuse may result in possible damage to the product.

Warning

6. Vacuum release flow adjustment needle

Adjust the vacuum release flow adjustment needle from the fully closed to the open state by 1/8 to 1/4 turns to detach a workpiece completely during the ON time of a release valve.

Do not supply compressed air while the vacuum release flow adjustment needle is adjusted. Securely lock it with a lock nut after adjustment.

7. How to use the latching type solenoid valve

Our Latching type solenoid are fitted with a self-detaining mechanism. Its construction features an armature inside the solenoid which is set or reset using spontaneous energization. (10 ms or greater) Therefore, continuous energization is not required.

How to Use the Latching Type Plug Connector

Wiring specifications

- Wiring should be connected as shown below. Connect with the power supply respectively.

DC positive common

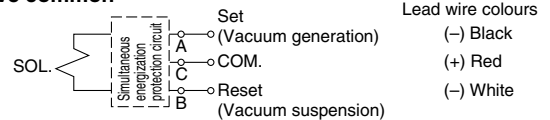

DC negative common

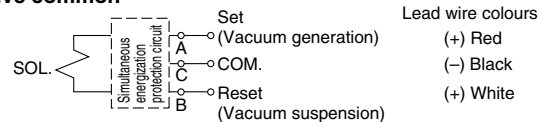

Special care must be taken for the latching type.

1. Avoid using this product with a circuit which electrifies both the set and reset signals simultaneously.
2. The minimum energization time required for self-detaining is 10 ms.
3. Please contact SMC when using this product in locations where there are vibration levels of 30 m/s² or above or highly magnetic fields. No problems arise in normal usage or locations.
4. This valve retains the reset position (Flow path: A → R) at the time of shipment. However, it may alter to the set position during transportation or due to vibration when mounting the valve. Therefore, confirm the home position either manually or

Mounting

Warning

1. Screw tightening torque for mounting the body should be performed with 0.6 ± 0.06 N·m.

Excessive torque may damage the product.

Safety Instructions

These safety instructions are intended to prevent hazardous situations and/or equipment damage. These instructions indicate the level of potential hazard with the labels of “**Caution**,” “**Warning**” or “**Danger**.” They are all important notes for safety and must be followed in addition to International Standards (ISO/IEC)*1), and other safety regulations.

 **Caution:** **Caution** indicates a hazard with a low level of risk which, if not avoided, could result in minor or moderate injury.

 **Warning:** **Warning** indicates a hazard with a medium level of risk which, if not avoided, could result in death or serious injury.

 **Danger:** **Danger** indicates a hazard with a high level of risk which, if not avoided, will result in death or serious injury.

*1) ISO 4414: Pneumatic fluid power – General rules relating to systems.
ISO 4413: Hydraulic fluid power – General rules relating to systems.
IEC 60204-1: Safety of machinery – Electrical equipment of machines.
(Part 1: General requirements)
ISO 10218-1: Manipulating industrial robots - Safety.
etc.

Warning

1. The compatibility of the product is the responsibility of the person who designs the equipment or decides its specifications.

Since the product specified here is used under various operating conditions, its compatibility with specific equipment must be decided by the person who designs the equipment or decides its specifications based on necessary analysis and test results. The expected performance and safety assurance of the equipment will be the responsibility of the person who has determined its compatibility with the product. This person should also continuously review all specifications of the product referring to its latest catalogue information, with a view to giving due consideration to any possibility of equipment failure when configuring the equipment.

2. Only personnel with appropriate training should operate machinery and equipment.

The product specified here may become unsafe if handled incorrectly. The assembly, operation and maintenance of machines or equipment including our products must be performed by an operator who is appropriately trained and experienced.

3. Do not service or attempt to remove product and machinery/equipment until safety is confirmed.

- The inspection and maintenance of machinery/equipment should only be performed after measures to prevent falling or runaway of the driven objects have been confirmed.
- When the product is to be removed, confirm that the safety measures as mentioned above are implemented and the power from any appropriate source is cut, and read and understand the specific product precautions of all relevant products carefully.
- Before machinery/equipment is restarted, take measures to prevent unexpected operation and malfunction.

4. Contact SMC beforehand and take special consideration of safety measures if the product is to be used in any of the following conditions.

- Conditions and environments outside of the given specifications, or use outdoors or in a place exposed to direct sunlight.
- Installation on equipment in conjunction with atomic energy, railways, air navigation, space, shipping, vehicles, military, medical treatment, combustion and recreation, or equipment in contact with food and beverages, emergency stop circuits, clutch and brake circuits in press applications, safety equipment or other applications unsuitable for the standard specifications described in the product catalogue.
- An application which could have negative effects on people, property, or animals requiring special safety analysis.
- Use in an interlock circuit, which requires the provision of double interlock for possible failure by using a mechanical protective function, and periodical checks to confirm proper operation.

Caution

1. The product is provided for use in manufacturing industries.

The product herein described is basically provided for peaceful use in manufacturing industries.
If considering using the product in other industries, consult SMC beforehand and exchange specifications or a contract if necessary.
If anything is unclear, contact your nearest sales branch.

Limited warranty and Disclaimer/ Compliance Requirements

The product used is subject to the following “Limited warranty and Disclaimer” and “Compliance Requirements”.

Read and accept them before using the product.

Limited warranty and Disclaimer

1. The warranty period of the product is 1 year in service or 1.5 years after the product is delivered.*2)

Also, the product may have specified durability, running distance or replacement parts. Please consult your nearest sales branch.

2. For any failure or damage reported within the warranty period which is clearly our responsibility, a replacement product or necessary parts will be provided.

This limited warranty applies only to our product independently, and not to any other damage incurred due to the failure of the product.

3. Prior to using SMC products, please read and understand the warranty terms and disclaimers noted in the specified catalogue for the particular products.

*2) Vacuum pads are excluded from this 1 year warranty.

A vacuum pad is a consumable part, so it is warranted for a year after it is delivered. Also, even within the warranty period, the wear of a product due to the use of the vacuum pad or failure due to the deterioration of rubber material are not covered by the limited warranty.

Compliance Requirements

1. The use of SMC products with production equipment for the manufacture of weapons of mass destruction (WMD) or any other weapon is strictly prohibited.

2. The exports of SMC products or technology from one country to another are governed by the relevant security laws and regulations of the countries involved in the transaction. Prior to the shipment of a SMC product to another country, assure that all local rules governing that export are known and followed.

Safety Instructions

Be sure to read “Handling Precautions for SMC Products” (M-E03-3) before using.

SMC Corporation (Europe)

Austria	☎+43 2262622800	www.smc.at	office@smc.at	Lithuania	☎+370 5 2308118	www.smclt.lt	info@smclt.lt
Belgium	☎+32 (0)33551464	www.smc-pneumatics.be	info@smcpneumatics.be	Netherlands	☎+31 (0)205318888	www.smc-pneumatics.nl	info@smcpneumatics.nl
Bulgaria	☎+359 29744492	www.smc.bg	office@smc.bg	Norway	☎+47 67129020	www.smc-norge.no	post@smc-norge.no
Croatia	☎+385 13776674	www.smc.hr	office@smc.hr	Poland	☎+48 222119600	www.smc.pl	office@smc.pl
Czech Republic	☎+420 541424611	www.smc.cz	office@smc.cz	Portugal	☎+351 226166570	www.smc.eu	postpt@smc.smces.es
Denmark	☎+45 70252900	www.smcdk.com	smc@smcdk.com	Romania	☎+40 213205111	www.smcromania.ro	smcromania@smcromania.ro
Estonia	☎+372 6510370	www.smc-pneumatics.ee	smc@smcpneumatics.ee	Russia	☎+7 8127185445	www.smc-pneumatik.ru	info@smc-pneumatik.ru
Finland	☎+358 207513513	www.smc.fi	smc@smc.fi	Slovakia	☎+421 413213212	www.smc.sk	office@smc.sk
France	☎+33 (0)164761000	www.smc-france.fr	contact@smc-france.fr	Slovenia	☎+386 73885412	www.smc.si	office@smc.si
Germany	☎+49 (0)61034020	www.smc-pneumatik.de	info@smc-pneumatik.de	Spain	☎+34 945184100	www.smc.eu	post@smc.smces.es
Greece	☎+30 210 2717265	www.smchellas.gr	sales@smchellas.gr	Sweden	☎+46 (0)86031200	www.smc.nu	post@smcpneumatics.se
Hungary	☎+36 23511390	www.smc.hu	office@smc.hu	Switzerland	☎+41 (0)523963131	www.smc.ch	info@smc.ch
Ireland	☎+353 (0)14039000	www.smc-pneumatics.ie	sales@smcpneumatics.ie	Turkey	☎+90 (0)2124440762	www.entek.com.tr	smc@entek.com.tr
Italy	☎+39 (0)292711	www.smcitalia.it	mailbox@smcitalia.it	UK	☎+44 (0)845 121 5122	www.smc-pneumatics.co.uk	sales@smcpneumatics.co.uk
Latvia	☎+371 67817700	www.smclv.lv	info@smclv.lv				