

An in-line type air suction filter that prevents trouble in vacuum equipment due to contaminants in the air

The ZFC05 series is now available!

Applicable tubing size: $\phi 2$, $\phi 3.2$, $\phi 4$, $\phi 1/8"$, $\phi 5/32"$
Smaller installation space: Total length 58 mm,
Outside diameter $\phi 10.5$

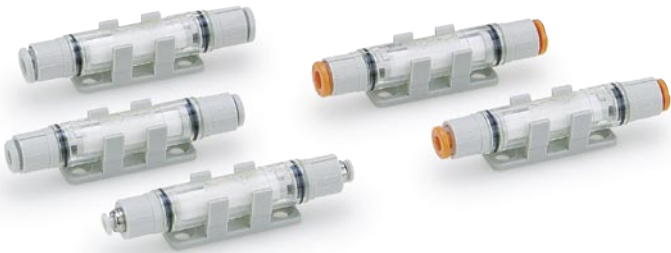

IN/OUT straight piping

Saves space with space efficient straight piping

Applicable tubing sizes

Metric size (Release bushing: Light gray)
 $\phi 2$, $\phi 3.2$, $\phi 4$, $\phi 6$, $\phi 8$

Inch size (Release bushing: Orange)
 $\phi 1/8"$, $\phi 5/32"$, $\phi 1/4"$, $\phi 5/16"$

One-touch fittings for easy installation and removal

Piping tube can be connected or disconnected with one-touch.

Lightweight molded resin parts

Weight: 4.3 g, Outside diameter $\phi 10.5$

* ZFC05 without bracket

Cartridge type allows element replacement.

The cover can be opened with one-touch to allow quick replacement without tools while the piping is still connected.

Air Suction Filter / In-line Type With One-touch Fittings

Series **ZFC**



Application Examples

- **Field:** Semiconductor, electronics, automotive assembly, food processing and medical equipment, all types of manufacturing assembly equipment
- **Machinery:** Robotic hand/material handling, automotive assembling machines, automatic transfer equipment, pick and place, printing machinery
- **Application:** Vacuum adsorption transfer, vacuum adsorption retention, vacuum generated air flow

Ejector System Application

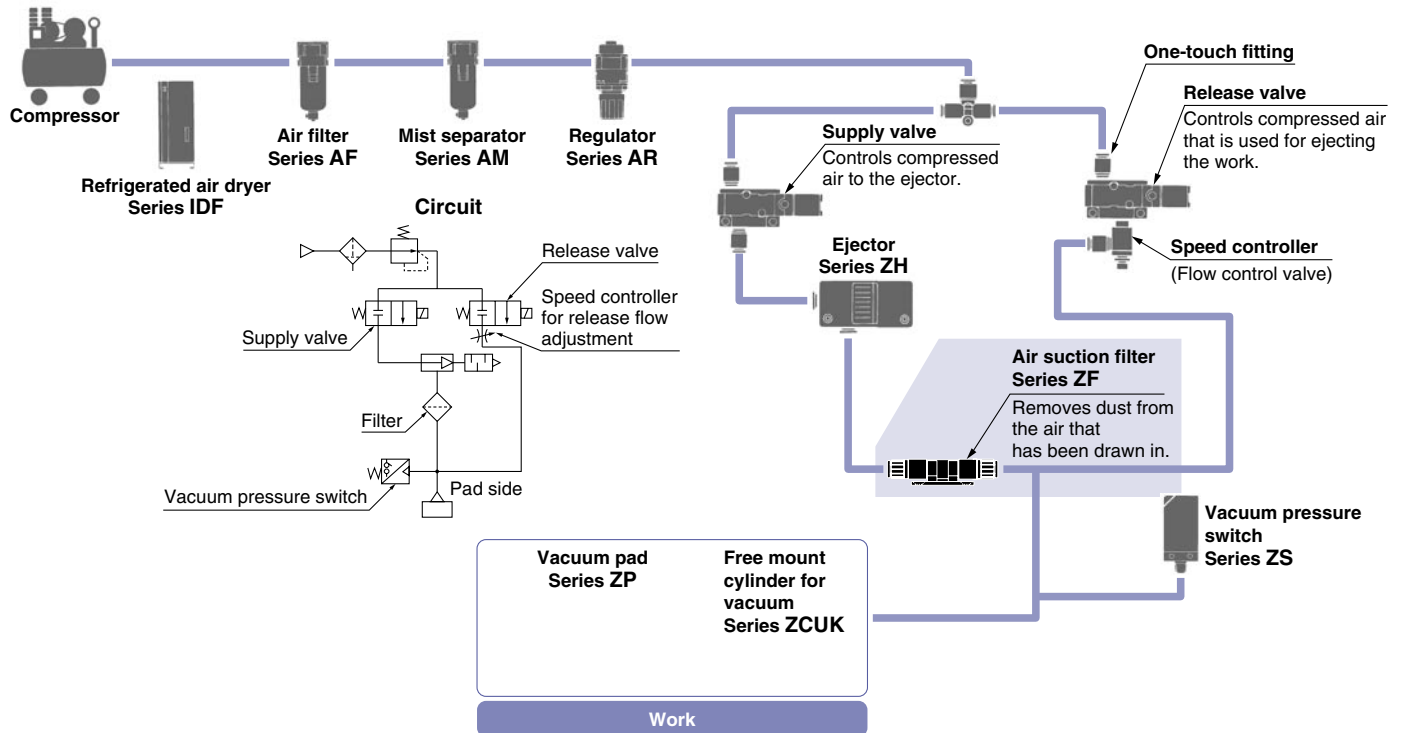

Vacuum Pump System Application

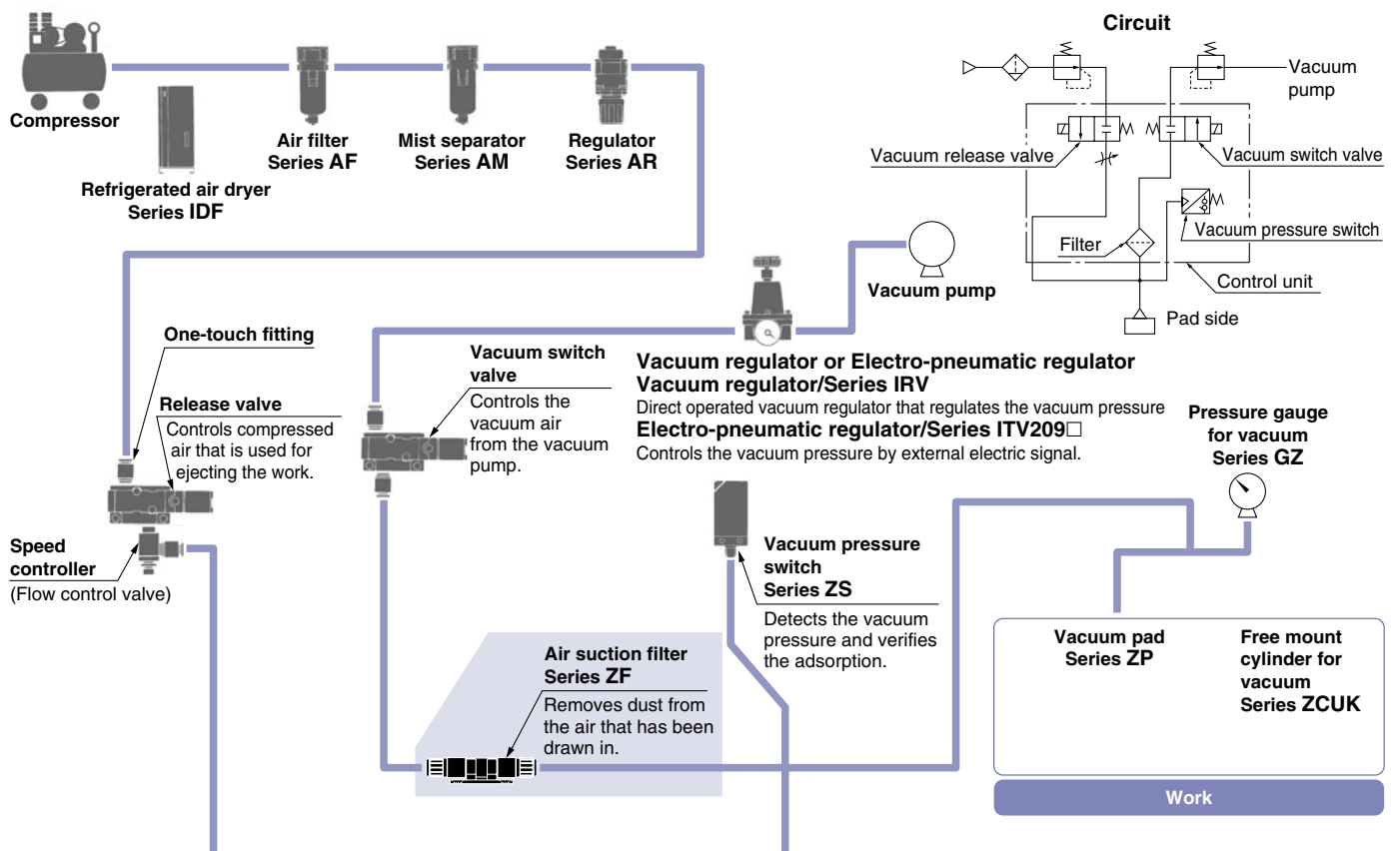

Air Suction Filter / In-line Type With One-touch Fittings

Series ZFC

How to Order

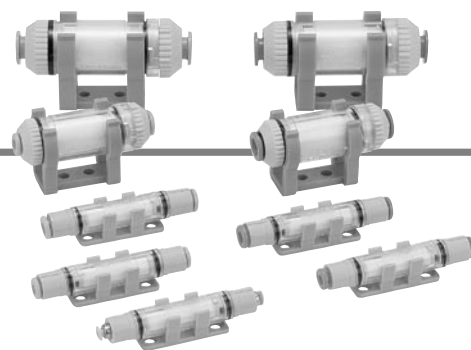

Metric size
(Release button: Light gray)

Metric size **ZFC 05 0-02 B**

Inch size **ZFC 05 1-01 B**

Body type

Symbol	Flow rate (ℓ/min (ANR))	Filtration area
05	Max. 10 ℓ/min	470 mm ²
10	Max. 20 ℓ/min	750 mm ²
20	Max. 50 ℓ/min	1255 mm ²

Option (With/Without bracket)

Symbol	Option
-	None (Without bracket)
B	With bracket

Applicable tubing size

Metric size

Symbol	Bore size	Applicable model		
		ZFC05	ZFC10	ZFC20
02	ø2	●	—	—
23	ø3.2	●	—	—
04	ø4	●	●	—
06	ø6	—	●	●
08	ø8	—	—	●

Inch size

Symbol	Bore size	Applicable model		
		ZFC05	ZFC10	ZFC20
01	ø1/8"	●	—	—
03	ø5/32"	●	●	—
07	ø1/4"	—	●	●
09	ø5/16"	—	—	●

Inch size
(Release button: Orange)

JIS symbol

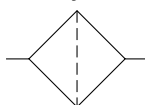

Replacement Element Part No.

Part no.	Applicable filter model	Element size (mm)	Set description	
			Spare element	O-ring for cover
I-68S-A	ZFC05	ø6 x ø4 x L25	10 pcs.	—
I-62S-A	ZFC10	ø12 x ø8 x L20	10 pcs.	10 pcs.
I-63S-A	ZFC20	ø16 x ø12 x L25	10 pcs.	10 pcs.

Note) Spare elements and O-rings for the cover (Applicable filter: ZFC10, 20) are sold in sets of 10 pieces each.

Principal Parts Material

Description	Material
Case	Special clear nylon
Cover	PBT
Element	PVF
O-ring, Seal	NBR

Model

Model	Port size (Applicable tubing O.D.)		Recommended flow rate ^{Note)} (ℓ/min (ANR))	Weight (g)
	IN side	OUT side		
Metric size	ZFC050-02	ø2	2	4.9
	ZFC050-23	ø3.2	7	
	ZFC050-04	ø4	10	4.3
	ZFC100-04	ø4	10	
	ZFC100-06	ø6	20	
	ZFC200-06	ø6	30	21.5
	ZFC200-08	ø8	50	
Inch size	ZFC051-01	ø1/8"	7	4.3
	ZFC051-03	ø5/32"	10	
	ZFC101-03	ø5/32"	10	11.5
	ZFC101-07	ø1/4"	20	
	ZFC201-07	ø1/4"	30	
	ZFC201-09	ø5/16"	50	21.5

Note) Flow rate when the initial pressure drop is 3 kPa or less.

Series ZFC

Specifications

Fluid ^{Note 1)}	Air, Nitrogen
Operating pressure ^{Note 2)}	-100 to 0 kPa
Vacuum release pressure	Max. 0.5 MPa
Operating and ambient temperature range	0 to 60°C (No freezing)
Nominal filtration rating	10 μm
Element differential pressure resistance	[ZFC10□, 20□] 0.15 MPa [ZFC05□] 0.10 MPa
Applicable tubing material ^{Note 3)}	Nylon, Soft nylon, Polyurethane, Soft polyurethane

Note 1) Do not use in an atmosphere containing chemicals, or where there is direct chemical contact since the body may be damaged.

Note 2) Do not use in a line where a pressurised condition is maintained since the body may be damaged.

Note 3) Polyurethane is only applicable for the ZFC050-02.

Flow Characteristics (Piping tube: Metric size, Inch size)

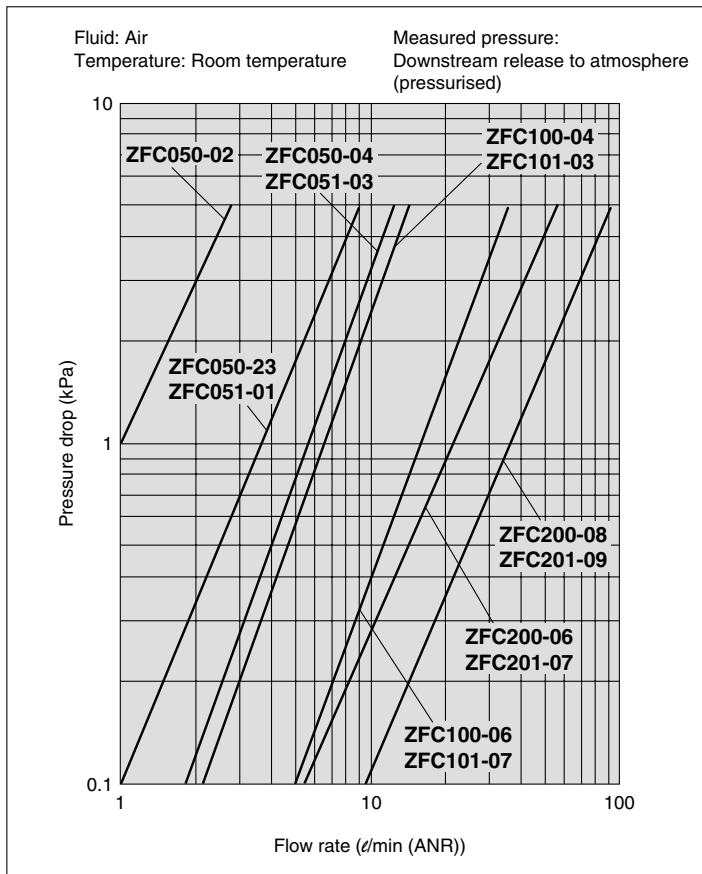

Construction

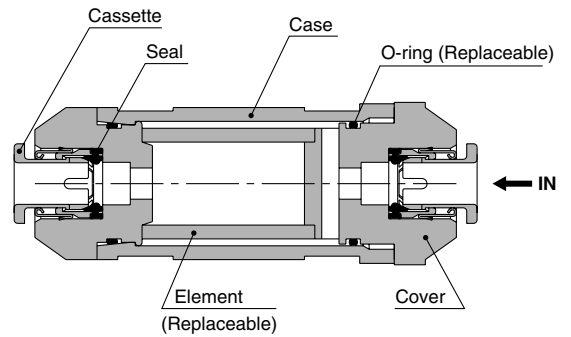

Dimensions

ZFC05

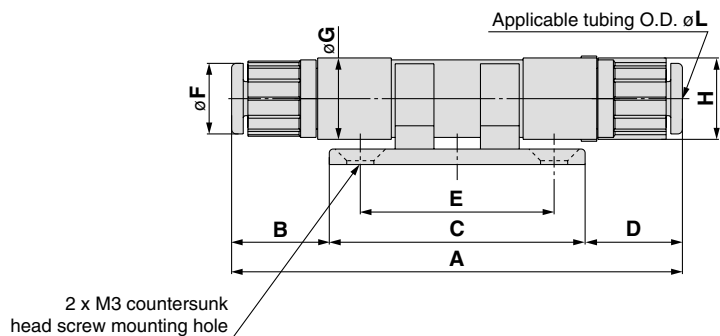
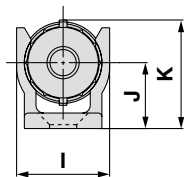

ZFC10, 20

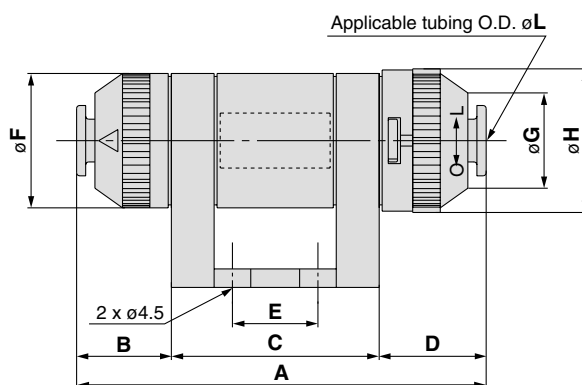
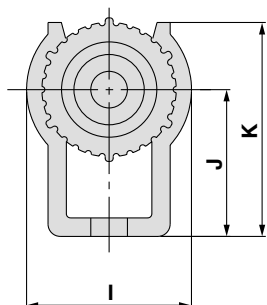

Model	A	B	C	D	E	F	G	H	I	J	K	L
ZFC050-02	58.5	12.75		12.75								2
ZFC050-23												3.2
ZFC050-04			33		25	10	10.5	10.5	12	8.5	13.75	4
ZFC051-01	58	12.5		12.5								1/8"
ZFC051-03												5/32"
ZFC100-04												4
ZFC100-06												6
ZFC101-03	53.2	9.1	30	14.1	10	18	11.6	19.5	23	20	29	5/32"
ZFC101-07												1/4"
ZFC200-06												6
ZFC200-08												8
ZFC201-07	67	15.5	34	17.5	14	22	15.6	23.1	27	24	35	1/4"
ZFC201-09												5/16"

Element Replacement

Element replacement procedure

1. Stop operation and reduce the filter's internal pressure to atmosphere.
2. Rotate the cover counterclockwise (toward the "O" on the O ⇒ L marking). Refer to Figure 1.

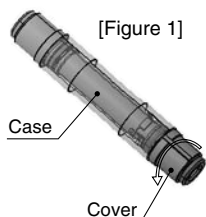

3. Pull the cover out of the case to remove the element. Remove dust and other debris remaining inside the case by blowing it out with air, etc. (Also, confirm that the O-ring is not damaged.)

4. Install a new element on cover and insert it into the case. Refer to Figure 2 and 3.

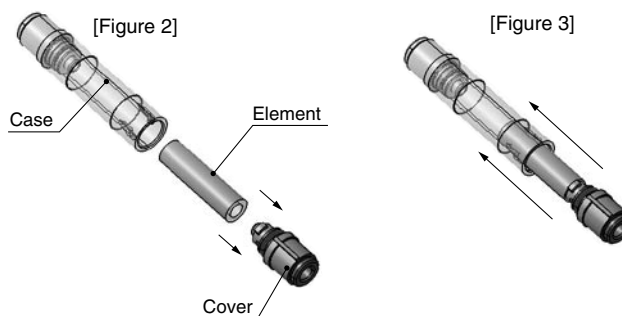

5. Adjust the protrusion on the cover and the slit on the case so that they match up, then push the cover into the end of the case. Next, confirm that the cover is locked by attempting to rotate it clockwise (toward the "L" on the O ⇒ L marking).
6. Restart operation.
[Figure: ZFC05□. The procedures for the ZFC10□, 20□ are alike.]





Series ZFC

Safety Instructions

These safety instructions are intended to prevent a hazardous situation and/or equipment damage. These instructions indicate the level of potential hazard by labels of "Caution", "Warning" or "Danger". To ensure safety, be sure to observe ISO 4414 ^{Note 1)}, JIS B 8370 ^{Note 2)} and other safety practices.

■ Explanation of the Labels

Labels	Explanation of the labels
 Danger	In extreme conditions, there is a possible result of serious injury or loss of life.
 Warning	Operator error could result in serious injury or loss of life.
 Caution	Operator error could result in injury ^{Note 3)} or equipment damage. ^{Note 4)}

Note 1) ISO 4414: Pneumatic fluid power – General rules relating to systems

Note 2) JIS B 8370: General Rules for Pneumatic Equipment

Note 3) Injury indicates light wounds, burns and electrical shocks that do not require hospitalisation or hospital visits for long-term medical treatment.

Note 4) Equipment damage refers to extensive damage to the equipment and surrounding devices.

■ Selection/Handling/Applications

1. The compatibility of the pneumatic equipment is the responsibility of the person who designs the pneumatic system or decides its specifications.

Since the products specified here are used in various operating conditions, their compatibility for the specific pneumatic system must be based on specifications or post analysis and/or tests to meet the specific requirements. The expected performance and safety assurance are the responsibility of the person who has determined the compatibility of the system. This person should continuously review the suitability of all items specified, referring to the latest catalogue information with a view to giving due consideration to any possibility of equipment failure when configuring a system.

2. Only trained personnel should operate pneumatic machinery and equipment.

Compressed air can be dangerous if handled incorrectly. Assembly, handling or repair of the systems using pneumatic equipment should be performed by trained and experienced operators. (Understanding JIS B 8370 General Rules for Pneumatic Equipment, and other safety rules are included.)

3. Do not service the machinery/equipment or attempt to remove components until safety is confirmed.

1. Inspection and maintenance of the machinery/equipment should only be performed once measures to prevent falling or runaway of the driven objects have been confirmed.
2. If the equipment must be removed, confirm the safety process as mentioned above. Turn off the supply pressure for the equipment and exhaust all residual compressed air in the system, and release all the energy (liquid pressure, spring, condenser, gravity).
3. Before the machinery/equipment is restarted, take measures to prevent quick extension of a cylinder piston rod, etc.

4. If the equipment will be used in the following conditions or environment, please contact SMC first and be sure to take all necessary safety precautions.

1. Conditions and environments beyond the given specifications, or if product is used outdoors.
2. Installation on equipment in conjunction with atomic energy, railway, air navigation, vehicles, medical equipment, food and beverages, recreation equipment, emergency stop circuits, clutch and brake circuits in press applications, or safety equipment.
3. An application which has the possibility of having negative effects on people, property, requiring special safety analysis.
4. If the products are used in an interlock circuit, prepare a double interlock style circuit with a mechanical protection function for the prevention of a breakdown. And, examine the devices periodically if they function normally or not.

■ Exemption from Liability

1. SMC, its officers and employees shall be exempted from liability for any loss or damage arising out of earthquakes or fire, action by a third person, accidents, customer error with or without intention, product misuse, and any other damages caused by abnormal operating conditions.

2. SMC, its officers and employees shall be exempted from liability for any direct or indirect loss or damage, including consequential loss or damage, loss of profits, or loss of chance, claims, demands, proceedings, costs, expenses, awards, judgments and any other liability whatsoever including legal costs and expenses, which may be suffered or incurred, whether in tort (including negligence), contract, breach of statutory duty, equity or otherwise.

3. SMC is exempted from liability for any damages caused by operations not contained in the catalogues and/or instruction manuals, and operations outside of the specification range.

4. SMC is exempted from liability for any loss or damage whatsoever caused by malfunctions of its products when combined with other devices or software.



Series ZFC Specific Product Precautions

Be sure to read this before handling.
For Vacuum Equipment and Precautions, refer to “Precautions for Handling Pneumatic Devices” (M-03-E3A).

Selection

Warning

1. Do not use in a line where a pressurised condition is maintained since the body may be damaged.

Mounting

Warning

1. Connect tubing to the IN and OUT one-touch fittings in accordance with the precautions for one-touch fittings.

Caution

1. Connect the piping in accordance with the flow direction marked on the case. Proper sealing of the element cannot be guaranteed if connections are reversed.

Maintenance

Warning

1. When the element becomes clogged, stop operation and release the internal pressure of the filter to atmospheric pressure before replacing the element.

Caution

1. As a rule, replace the element when the pressure drops by 20 kPa.
2. During disassembly and assembly, confirm that there are no scratches or damage, etc, on the O-ring.
3. Before using, confirm there is no leakage after replacing elements.

Operating Environment

Warning

1. Do not use tubings in atmospheres of corrosive gases, chemicals, salt water, water steam, or where there is direct contact with any of these.

Handling of One-touch Fittings

Caution

1. Tubing attachment/detachment for one-touch fittings
 - 1) Installation of tubing
 - (1) Use tubing with no flaws on its periphery and cut it off at a right angle. When cutting the tubing, use a tube cutter, TK-1, 2 or 3. Do not use pinchers, nippers or scissors, etc. If cutting is done with tools other than tube cutters, the tubing may be cut diagonally or become flattened, etc. This can make a secure installation impossible, and cause problems such as the tubing pulling out after installation or air leakage. Allow some extra length in the tubing.
 - (2) The outside diameter of the polyurethane tubing swells when internal pressure is applied to it. Therefore, it may not be possible that the tubing can be re-inserted into the one-touch fitting. Confirm the tubing outside diameter, and when the accuracy of the outside diameter is +0.15 or larger, re-insert the tubing into the one-touch fitting without cutting it. When the tubing is re-inserted into the one-touch fitting, confirm that the tubing goes through the release button smoothly.
 - (3) Grasp the tubing and push it in slowly, inserting it securely all the way into the fitting.
 - (4) After inserting the tubing, pull on it lightly to confirm that it will not come out. If it is not installed securely all the way into the fitting, this can cause problems such as air leakage or the tubing pulling out.
 - 2) Removal of tubing
 - (1) Push in the release button sufficiently. When doing this, push the collar evenly.
 - (2) Pull out the tubing while holding down the release button so that it does not come out. If the release button is not pressed down sufficiently, there will be increased bite on the tubing and it will become more difficult to pull out.
 - (3) When the removed tubing is to be used again, cut off the portion which has been chewed before reusing it. If the chewed portion of the tubing is used as it is, this can cause trouble such as air leakage or difficulty in removing the tubing.
2. Do not install the SMC's KQ one-touch fitting series with a metal rod into the ZFC05/10 series fittings. The metal rod will not be held and the fitting will shoot out.

Other Tube Brands

Caution

1. When tubing of brands other than SMC's are used, verify that the tubing O.D. satisfies the following accuracy;
 - 1) Nylon tubing : Within ± 0.1 mm
 - 2) Soft nylon tubing : Within ± 0.1 mm
 - 3) Polyurethane tubing: Within +0.15 mm, within -0.2 mmDo not use tubing which does not meet these outside diameter tolerances.
It may not be possible to connect them, or they may cause other trouble, such as air leakage or the tube pulling out after connection.
2. Tubing O.D: $\varnothing 2$
Other tube brands cannot be used. It may not be possible to connect them, or they may cause other trouble, such as air leakage or the tube pulling out after connection.

Air Suction Filters

Series ZFA/ZFB

For details on air suction filters, ZFA/ZFB series, refer to SMC's "Best Pneumatics" catalogue.

Model

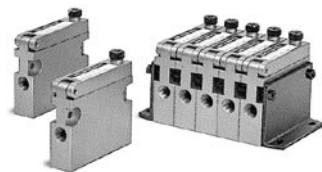

ZFA



ZFB

Model		Port size (Applicable tubing O.D.)	Recommended flow rate (ℓ /min (ANR))	Weight (g)
High flow rate square type	ZFA100	1/8	50	140
	ZFA200	1/4	200	190
Universal type	ZFB10□	$\phi 4, \phi 6, \phi 3/16", \phi 1/4"$	10 to 20	22
	ZFB20□	$\phi 6, \phi 8, \phi 1/4"$	30 to 50	30
	ZFB30□	$\phi 10, \phi 3/8"$	75	40
	ZFB401	$\phi 1/2"$	100	62

Specifications

Fluid	Air, Nitrogen
Operating pressure	Negative pressure
Withstand pressure	0.5 MPa
Operating and ambient temperature range	0 to 60°C (No freezing)
Nominal filtration rating	30 μ m
Element differential pressure resistance	0.15 MPa
Applicable tubing material	Nylon, Soft nylon, Polyurethane, Soft polyurethane

Note) ZFB series: Do not use in a line where a pressurised condition is maintained since the body may be damaged.

Related Products

$\phi 2$ Piping Series

For details on $\phi 2$ piping series, refer to the individual catalogue CAT. ES50-25.

One-touch Mini Series KJ



Miniature Fittings Series M



Speed Controller with One-touch Fittings Series AS



Min. bending radius: 4 mm

Polyurethane Tubing Series TU

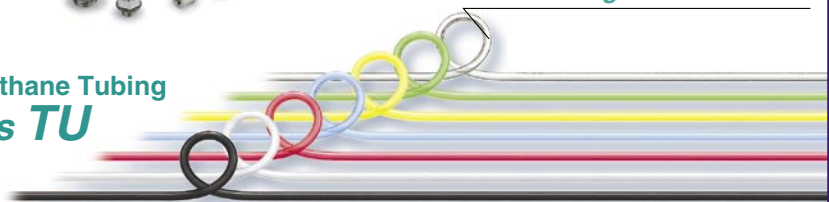

Safety Instructions

Be sure to read "Precautions for Handling Pneumatic Devices" (M-03-E3A) before using.

SMC Corporation

SMC CORPORATION
Akihabara UDX 15F, 4-14-1, Sotokanda, Chiyoda-ku, Tokyo 101-0021, JAPAN
Phone: 03-5207-8249 FAX: 03-5298-5362
SMC CORPORATION All Rights Reserved

European Marketing Centre (EMC)

Zuazobidea 14, 01015 Vitoria
Tel: +34 945-184 100 Fax: +34 945-184 124
URL <http://www.smceu.com>