











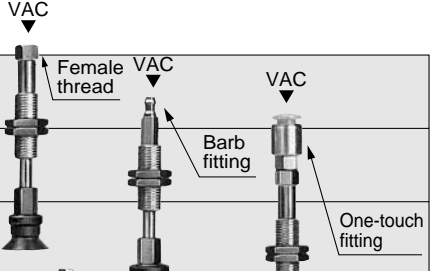



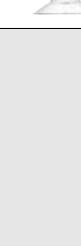

Vacuum Pad

Series ZP

Series	Without Buffer		With buffer		Non-rotating Stroke ø2 to ø8: 6, 10, 15, 25mm ø10 to ø32: 10, 20, 30, 40, 50mm ø40, ø50: 10, 20, 30, 50mm
	Vacuum Entry	Mounting	Vacuum Entry	Mounting	
 P.3.9-2 to P.3.9-27 Series ZPT Vertical Vacuum Entry	Male thread	(Common)			 Female thread, Barb fitting, One-touch fitting, Buffer body
	Female thread	(Common)			
 P.3.9-28 to P.3.9-43 Series ZPR Lateral Vacuum Entry With One-touch fitting	One-touch fitting	Male thread			
	One-touch fitting	Female thread			 One-touch fitting, Buffer body
 P.3.9-44 to P.3.9-57 Series ZPY Lateral Vacuum Entry With barb fitting	Barb fitting	Male thread			 Barb fitting, Buffer body
	Barb fitting	Female thread			

- ZX
- ZR
- ZM
- ZY
- ZH
- ZU
- ZL
- ZF
- ZP**
- ZCU
- CYV
- Vacuum related

Pad style
(Compatible with all models)

Flat style (U)  Flat with ribs (C)  Deep style (D)  Bellows style (B) 

Pad diameter	ø2	ø4	ø6	ø8	ø10	ø13	ø16	ø20	ø25	ø32	ø40	ø50
Flat	●	●	●	●	●	●	●	●	●	●	●	●
Flat with ribs	—	—	—	—	●	●	●	●	●	●	●	●
Deep	—	—	—	—	●	—	●	—	●	—	●	—
Bellows	—	—	●	●	●	●	●	●	●	●	●	●

Pad diameter (ø 2 to ø 125)

ø2 to ø125 (Option: ø150 to ø250)



Pad material

NBR (Black), Silicon rubber (White), Urethane rubber (Brown), Fluorine rubber (Black with green mark), Conductive NBR (Black with one white mark), Conductive silicon rubber (Black with two white marks)

 **Selection of Pad** Refer to technical data on page P.3.0-7 to P.3.0-14 for the calculation of lift force and response time.

Option ① Long stroke ② Oval pad ③ Ball joint pad ④ Large size pad

Pad material and Characteristics

Material	Item	Durometer HS (±5°)	Operating press. range (°C)	Oil resistance (gasoline)	Oil resistance (benzol)	Alkaline resistance	Acid resistance	Weatherability	Ozone resistance	Abrasion resistance	Water resistance	Solvents (benzene, toluene)
NBR		50°	0 to 120	○	X	○	○	○	X	○	○	X
Silicon rubber		40°	-30 to 200	X	X	○	X	○	○	X	○	X
Urethane rubber		60°	0 to 60	○	X	X	X	○	○	○	X	X
Fluorine rubber		60°	0 to 250	○	○	X	○	○	○	○	○	○
Conductive NBR		50°	0 to 100	○	X	○	X	○	X	○	○	X
Conductive silicon rubber		50°	-10 to 200	X	X	○	X	○	○	X	○	X

The above table covers only general characteristics of subject rubber materials.
Pad materials used by SMC pass JIS standards; however the actual performance depends on operating conditions.



ZPT

Vertical Vacuum Entry/without Buffer



Specifications

Vacuum entry	Direction		Vertical	
	Connection		Male thread	Female thread
	Thread dia.	ø2 to ø8	M5, M6	M4, M5
		ø10 to ø16	M5, M6	M5, M6, Rc(PT) 1/8
ø20 to ø32		M6, M8 X 1	M5, M6, M8, Rc(PT) 1/8	
	ø40, 50	M6, M8 X 1	M6, M8, Rc(PT) 1/8	
Mounting		Use connection for vacuum entry		

Pad Style

Pad style	Flat	Flat with ribs	Deep	Bellows
Pad dia. (mm)	2, 4, 6, 8, 10, 13, 16, 20, 25, 32, 40, 50	10, 13, 16, 20, 25, 32, 40, 50	10, 16, 25, 40	6, 8, 10, 13, 16, 20, 25, 32, 40, 50
Material (colour)	NBR(Black), Silicon rubber (White), Urethane rubber (Brown), Fluorine rubber (Black with green mark) Conductive NBR (Black with one white mark), Conductive silicon rubber (Black with two white marks)			
Durometer	NBR (50°), Silicon rubber (40°), Urethane rubber/Fluorine rubber (60°) Conductive NBR (50°), Conductive silicon rubber (50°)			

Weight Table/Male Thread (Female Thread)

(g)

Model	Flat				Flat with ribs				Deep				Bellows			
	M4	M5	M6	M8 Rc(PT) 1/8	M5	M6	M8 Rc(PT) 1/8	M5	M6	M8 Rc(PT) 1/8	M4	M5	M6	M8 Rc(PT) 1/8		
ZPT02 to ZPT08	— (3.5)	2.5 (3)	3.5 (—)	—	—	—	—	—	—	—	—	—	—	—	—	
ZPT10	—	—	—	—	—	—	—	10 (7)	12 (6)	— (13)	—	—	—	—	—	
ZPT13	—	10 (6.5)	12 (6)	— (13)	10 (6.5)	12 (6)	— (12)	—	—	—	—	—	—	—	—	
ZPT16	—	—	—	—	—	—	—	11 (7)	13 (7)	15 (13)	—	—	—	—	—	
ZPT20	—	—	—	—	—	—	—	—	—	—	—	—	—	—	—	
ZPT25	—	— (8.5)	15 (8)	26 (17)	— (16)	15 (8.5)	26 (17)	— (16)	15 (10)	26 (18)	— (17)	—	15 (8.5)	16 (8)	— (17)	
ZPT32	—	—	—	—	—	—	—	—	—	—	—	—	—	—	—	
ZPT40	—	—	28 (26)	30 (25)	— (23)	28 (26)	30 (25)	— (16)	30 (28)	32 (26)	— (20)	—	28 (26)	30 (25)	— (23)	
ZPT50	—	—	30 (29)	32 (27)	— (25)	32 (30)	34 (29)	— (27)	—	—	—	—	30 (29)	32 (27)	— (25)	

*(): Figures for female thread connections

Model

Model	Pad dia.	Applicable pad shape				Connection/Thread dia.	
		Flat (U)	Flat with ribs (C)	Deep (D)	Bellows (B)	Male thread	Female thread
ZPT02□□-□	2	●	—	—	—	M5	M4
ZPT04□□-□	4	●	—	—	—		
ZPT06□□-□	6	●	—	—	●		
ZPT08□□-□	8	●	—	—	●	M6	M5
ZPT10□□-□	10	●	●	●	●		
ZPT13□□-□	13	●	●	—	●	M5	M5
ZPT16□□-□	16	●	●	●	●		
ZPT20□□-□	20	●	●	●	●	M6	Rc(PT) 1/8
ZPT25□□-□	25	●	●	●	●		
ZPT32□□-□	32	●	●	—	●	M6	M5
ZPT40□□-□	40	●	●	●	●		
ZPT50□□-□	50	●	●	—	●	M8 X 1	M6
						M8 X 1	M8
							Rc(PT) 1/8



P.3.9-64 to 3.9-69

Vertical Vacuum Entry without Buffer Series ZPT

How to Order

Series ZPT
without buffer

ZPT 02 U N A5

Pad dia. (mm)

02	ø2
04	ø4
06	ø6
08	ø8
10	ø10
13	ø13
16	ø16
20	ø20
25	ø25
32	ø32
40	ø40
50	ø50

Pad style

(Refer to Table ① for applications.)

U	Flat
C	Flat with ribs
D	Deep
B	Bellows

Table ① Pad Dia. /Pad Style

Type \ Dia. (mm)	Dia. (mm)											
	2	4	6	8	10	13	16	20	25	32	40	50
Flat	●	●	●	●	●	●	●	●	●	●	●	●
Flat with ribs	—	—	—	—	●	●	●	●	●	●	●	●
Deep	—	—	—	—	●	—	●	—	●	—	●	—
Bellows	—	—	●	●	●	●	●	●	●	●	●	●

Vacuum entry

Thread	Symbol	Thread dia.	Pad dia. (mm)			
			ø2 to ø8	ø10 to ø16	ø20 to ø32	ø40 to ø50
Male thread	A5	M5	●	●	—	—
	A6	M6	●	●	●	●
	A8	M8 X 1	—	—	●	●
Female thread	B4	M4	●	—	—	—
	B5	M5	●	●	●	—
	B6	M6	—	●	●	●
	B8	M8	—	—	●	●
B01	Rc(PT)1/8	—	—	●	●	

Material

N	NBR
S	Silicon rubber
U	Urethane rubber
F	Fluorine rubber
GN*	Conductive NBR (ø2 to ø16)
GS*	Conductive silicon rubber (ø2 to ø16)

*ø20 and larger are manufactured upon receipt of order.

ZX

ZR

ZM

ZY

ZH

ZU

ZL

ZF

ZP

ZCU

CYV

Vacuum related

⚠️ Precaution

Be sure to read before handling. Refer to p.0-20 and 0-21 for Safety Instructions and common precautions on the products mentioned in this catalogue, and refer to p.3.0-2 for detailed precautions on every series.

Design

⚠️ Warning

- ① In cases where the work pieces are heavy or dangerous, etc., take measures to address a possible loss of adsorption force (installation of drop prevention guides, etc.).

In the case of transportation by vacuum adsorption using vacuum pads, adsorption force is lost when there is a drop in vacuum pressure. Furthermore, since vacuum pressure can also deteriorate due to wear and cracking of pads, and vacuum leakage from piping, etc., be certain to perform maintenance on vacuum equipment.

Selection

⚠️ Caution

- ① The pad materials differ depending upon the operating environment.

An appropriate pad material should be selected. Furthermore, since vacuum pads are manufactured for use with industrial products, they should not have direct contact with pharmaceuticals or food products, etc.

- ② Depending upon the weight and shape of the work pieces, the diameter, quantity and shape of pads will vary.

Use the pad lifting force table for reference. Also, the pads selected will differ based upon conditions other than the above, such as the condition of the work piece surface (presence or absence of oil or water), the work piece material and its gas permeability. Confirmation is necessary by actually performing vacuum adsorption testing on the subject work pieces.

- ③ Use a buffer for adsorption on fragile work pieces.

The cushioning by the buffer is necessary when there is variation in the height of work pieces. When further positioning of pads and work pieces is desired, a detent buffer can be used.

- ④ The life of the buffer will be reduced if lateral force is applied to the buffer shaft.

Note that sometimes a load is applied to the buffer by a piping tube (pulling or pressing, etc. in a lateral direction).

- ⑤ Do not apply an impact or large forces to a pad when adsorbing a work piece.

This will cause deformation, cracking and wear of the pad to be accelerated. The stiffening ribs, etc. should touch lightly, while staying within the pad skirt's deformation range. Positioning should be performed accurately. Especially in the case of small diameter pads.

- ⑥ When transporting in an upward direction, factors such as acceleration, wind pressure and impact force must be considered in addition to the work piece weight.

Use caution particularly when lifting items such as glass plates and circuit boards, because a large force will be applied by wind pressure. When a work piece which is oriented vertically is transported horizontally, large forces are applied by acceleration when movement is started and stopped. Further, in cases where the pad and work piece can slip easily, accelerations and decelerations of horizontal movement should be kept low.

- ⑦ When transporting flat work pieces that have large surface areas using multiple pads, care must be taken when arranging the pads to balance the work piece.

Maintenance

⚠️ Caution

- ① Perform pad maintenance regularly.

Since pads are essentially rubber, deterioration is unavoidable. The rate of deterioration depends upon factors such as conditions of use, environment and temperature. Regular maintenance should be performed. If any damage, splitting, cracking or abrasion has occurred in a pad which appears to be harmful, replace it immediately. Also, take care not to damage the outside of the pad.

Series ZPT

Connection	Male Thread	Pad Style	Flat/Flat with Ribs/Deep
Vacuum Entry	Vertical	Mounting	Use Connection for Vacuum Entry

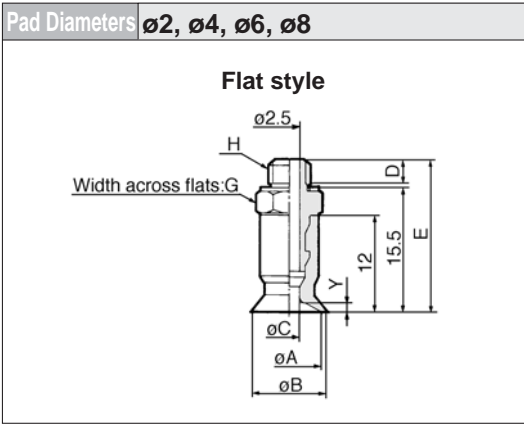

Flat style

Model	øA	øB	øC	H: M5			H: M6			Y
				D	E	G	D	E	G	
ZPT02U	2	2.6	1.2	3	19	7	4	20	8	0.8
ZPT04U	4	4.8	1.6							
ZPT06U	6	7	2.5							
ZPT08U	8	9								1

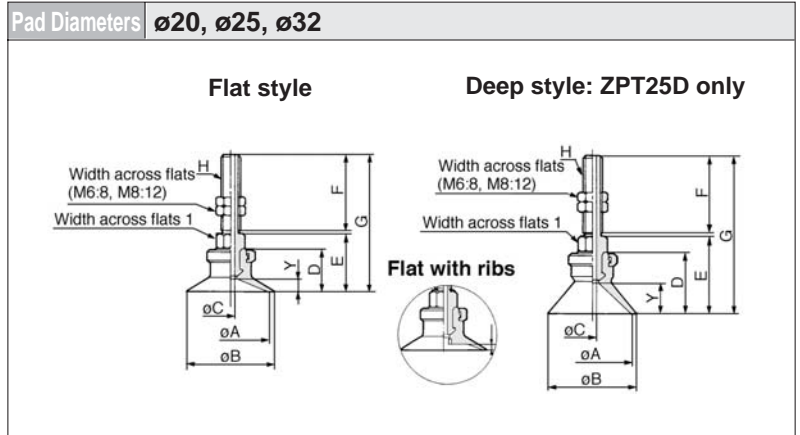

Flat style/Flat with ribs

Model	øA	øB	D	H: M6					H: M8 X 1					Y	
				øC	E	F	G	I	øC	E	F	G	I	Flat	Flat w/ ribs
ZPT20 ^U _C	20	23	14	3	19	25	45	8	3.5	24	15	40	12	4	1.7
ZPT25 ^U _C	25	28													
ZPT32 ^U _C	32	35	14.5												

Deep style

Model	øA	øB	D	H: M6					H: M8 X 1					Y
				øC	E	F	G	I	øC	E	F	G	I	
ZPT25D	25	28	20	3	25	25	51	8	3.5	30	15	46	12	10

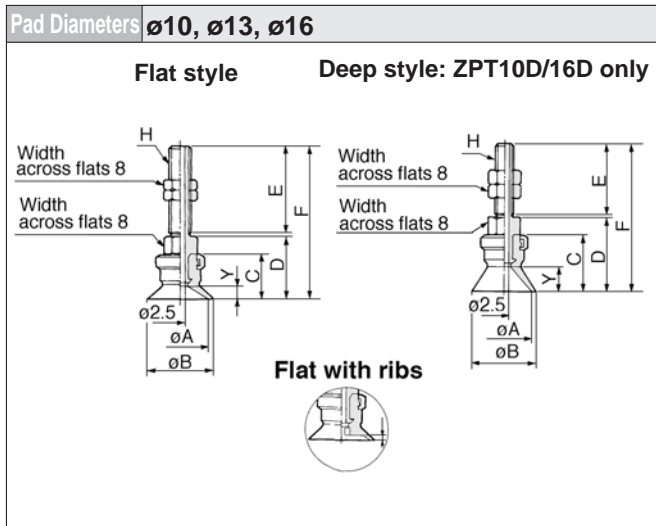

Flat style/Flat with ribs

Model	øA	øB	C	D	H: M5		H: M6		Y	
					E	F	E	F	Flat	Flat w/ ribs
ZPT10 ^U _C	10	12	12	17	20	38	25	43	3	1.7
ZPT13 ^U _C	13	15								
ZPT16 ^U _C	16	18	12.5	17.5						

Deep style

Model	øA	øB	C	D	H: M5		H: M6		Y
					E	F	E	F	
ZPT10D	10	12	15	20	20	41	25	46	6
ZPT16D	16	18	16	21	20	42	25	47	7

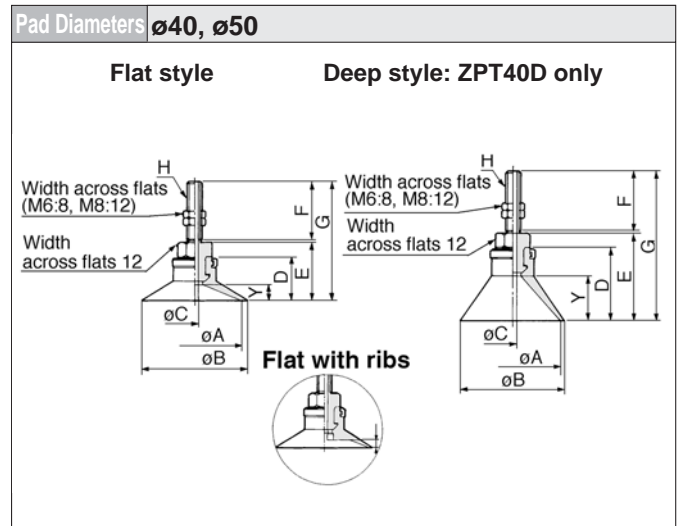

Flat style/Flat with ribs

Model	øA	øB	D	E	H: M6			H: M8 X 1			Y	
					øC	F	G	øC	F	G	Flat	Flat w/ ribs
ZPT40 ^U _C	40	43	18.5	24.5	3	25	50.5	4.5	15	40.5	6.5	3.3
ZPT50 ^U _C	50	53	19.5	25.5								

Deep style

Model	øA	øB	D	E	H: M6			H: M8 X 1			Y
					øC	F	G	øC	F	G	
ZPT40D	40	43	29	35.5	3	25	61	4.5	15	51	17

Vertical Vacuum Entry without Buffer Series ZPT

Connection	Male Thread	Pad Style	Bellows
Vacuum Entry	Vertical	Mounting	Use Connection for Vacuum Entry

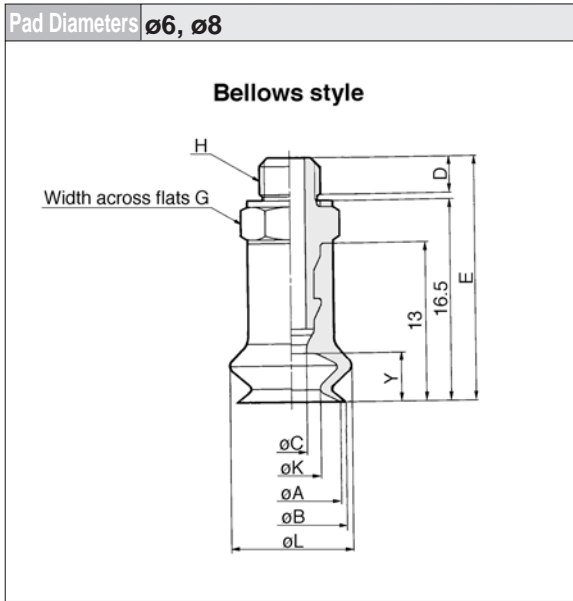

Model	øA	øB	øC	H: M5			H: M6			øK	øL	Y
				D	E	G	D	E	G			
ZPT06B	6	7	2.5	3	20	7	4	21	8	3.3	9.1	4
ZPT08B	8	9								4.7	10.1	

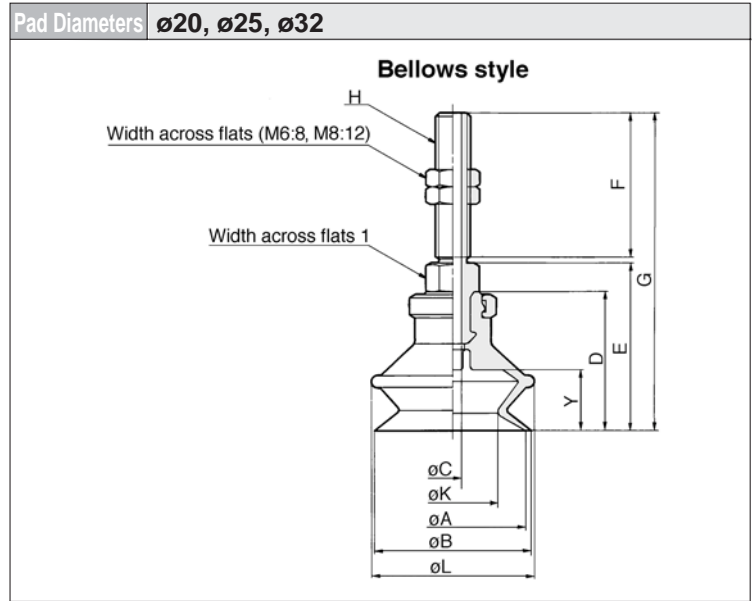

Model	øA	øB	D	H: M6					H: M8 X 1					øK	øL	Y
				øC	E	F	G	I	øC	E	F	G	I			
ZPT20B	20	22	23.5		28.5	54.5					33.5	49.5		12.4	25	10.5
ZPT25B	25	27	24	3	29	55	8	3.5	34	15	50	12	15.6	28	10.5	
ZPT32B	32	34	29		34	60				39	55		18.9	37	14	

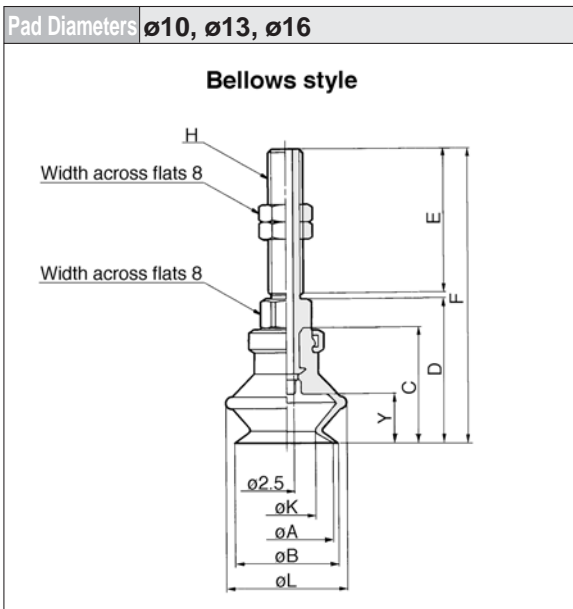

Model	øA	øB	øC	D	H: M5		H: M6		øK	øL	Y
					E	F	E	F			
ZPT10B	10	12	16	21		42		47	5.5	13.8	5.5
ZPT13B	13	15	18.5	23.5	20	44.5	25	49.5	8.7	19	7.5
ZPT16B	16	18	20	25		46		51	9.9	21	8.5

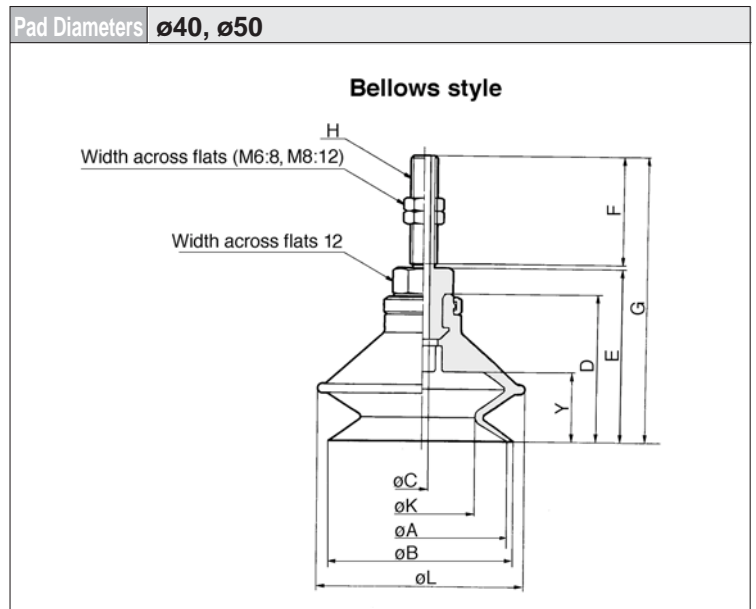

Model	øA	øB	D	E	H: M6			H: M8 X 1			øK	øL	Y	
					øC	F	G	øC	F	G				
ZPT40B	40	43	34	40		66			4.5	15	56	24.4	48	16
ZPT50B	50	53	38	44	3	25	70			60	32.4	57	19	

- ZX
- ZR
- ZM
- ZY
- ZH
- ZU
- ZL
- ZF
- ZP
- ZCU
- CYV
- Vacuum related

Series ZPT

Connection	Female Thread	Pad Style	Flat/Flat with Ribs/Deep
Vacuum Entry	Vertical	Mounting	Use Connection for Vacuum Entry

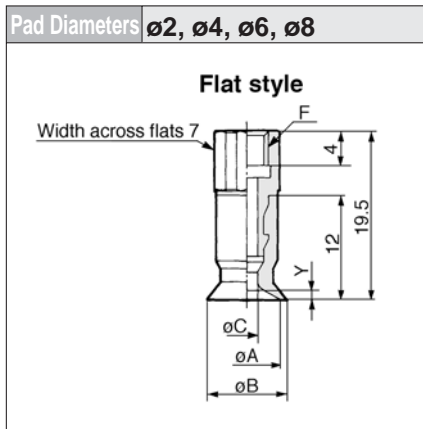

Flat style

Model	øA	øB	C	F	Y
ZPT02U	2	2.6	1.2	M4	0.8
ZPT04U	4	4.8	1.6		
ZPT06U	6	7	2.5	M5	1
ZPT08U	8	9			

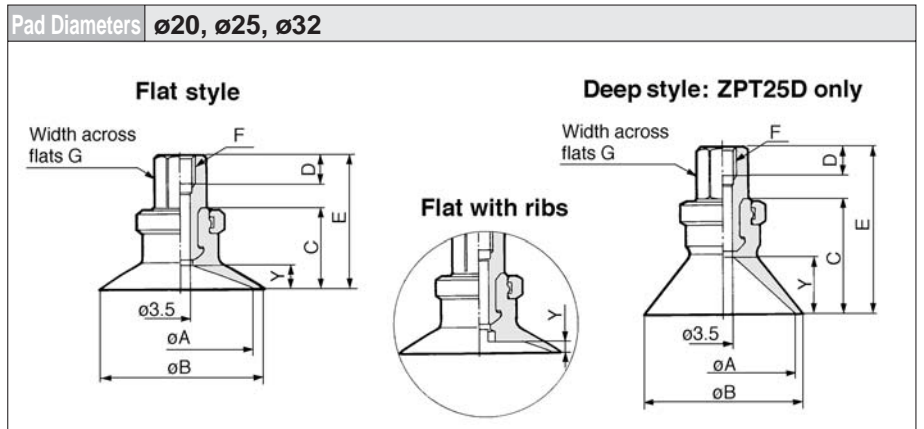

Flat style/Flat with ribs

Model	øA	øB	C	F: M5			F: M6			F: M8			F: Rc(PT) 1/8			Y	
				D	E	G	D	E	G	D	E	G	D	E	G	Flat	Flat w/ ribs
ZPT20 ^U _C	20	23	14	5	23	8	6	23	8	8	29	12	6.2	29	12	4	1.7
ZPT25 ^U _C	25	28	14.5	5	23.5	8	6	23.5	8	8	29.5	12	6.2	29.5	12	4.5	2.3
ZPT32 ^U _C	32	35															

Deep style

Model	øA	øB	C	F: M5			F: M6			F: M8			F: Rc(PT) 1/8			Y
				D	E	G	D	E	G	D	E	G	D	E	G	
ZPT25D	25	28	20	5	29	8	6	29	8	8	35	12	6.2	35	12	10



Weight Table

Weight table for female thread:
Refer to p.3.9-2.

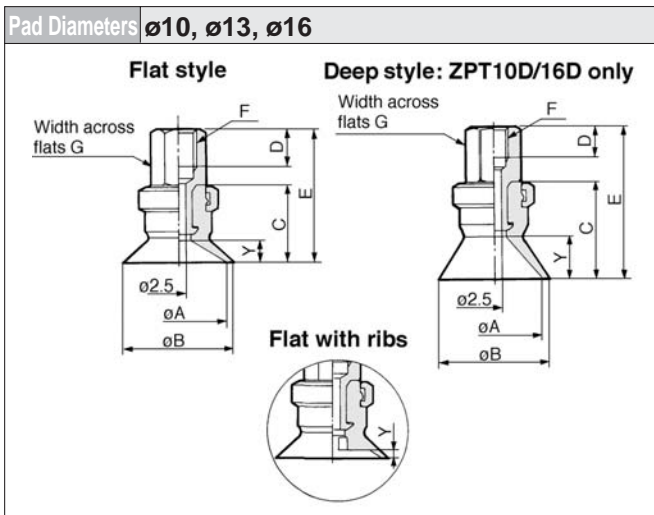

Flat style/Flat with ribs

Model	øA	øB	C	F: M5			F: M6			F: Rc(PT) 1/8			Y	
				D	E	G	D	E	G	D	E	G	Flat	Flat w/ ribs
ZPT10 ^U _C	10	12	12	5	21	8	6	21	8	6.2	27	12	3	1.7
ZPT13 ^U _C	13	15												
ZPT16 ^U _C	16	18	12.5	5	21.5	8	6	21.5	8	6.2	27.5	12	3.5	1.2

Deep style

Model	øA	øB	C	F: M5			F: M6			F: Rc(PT) 1/8			Y
				D	E	G	D	E	G	D	E	G	
ZPT10D	10	12	15	5	24	8	6	24	8	6.2	30	12	6
ZPT16D	16	18	16	5	25	8	6	25	8	6.2	31	12	7

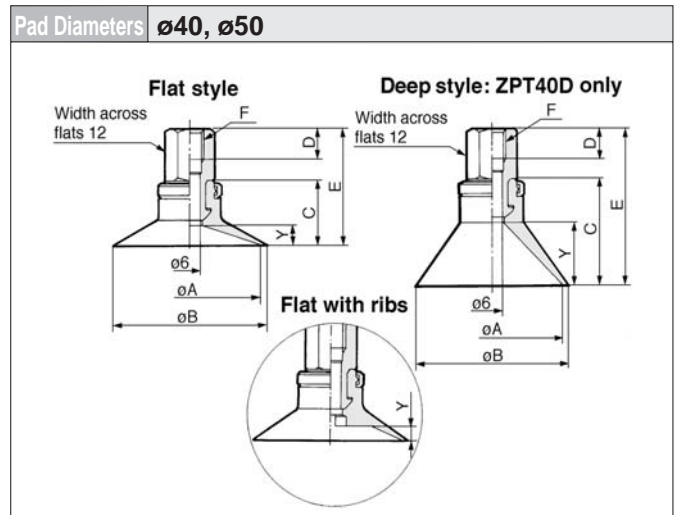

Flat style/Flat with ribs

Model	øA	øB	C	F: M6			F: M8			F: Rc(PT) 1/8			Y	
				D	E	G	D	E	G	D	E	G	Flat	Flat w/ ribs
ZPT40 ^U _C	40	43	18.5	6	8	6.2	32	6.5	3.3					
ZPT50 ^U _C	50	53	19.5	6	8	6.2	33	7.5	3.8					

Deep style

Model	øA	øB	C	F: M6			F: M8			F: Rc(PT) 1/8			E	Y
				D	E	G	D	E	G	D	E	G		
ZPT40D	40	43	29	6	8	6.2	42.5	17						

Vertical Vacuum Entry without Buffer Series ZPT

Connection	Female Thread	Pad Style	Bellows
Vacuum Entry	Vertical	Mounting	Use Connection for Vacuum Entry

Pad Diameters **ø6, ø8**

Bellows style

Model	øA	øB	øC	F	øK	øL	Y
ZPT06B	6	7	2.5	M4	3.3	9.1	4
ZPT08B	8	9		M5	4.7	10.1	

Pad Diameters **ø20, ø25, ø32**

Bellows style

Model	øA	øB	øC	F: M5			F: M6			F: M8			F: Rc(PT) 1/8			øK	øL	Y
				D	E	G	D	E	G	D	E	G	D	E	G			
ZPT20B	20	22	23.5	5	32.5	8	6	32.5	8	8	38.5	12	6.2	38.5	12	12.4	25	10.5
ZPT25B	25	27	24	5	33	8	6	33	8	8	39	12	6.2	39	12	15.6	28	10.5
ZPT32B	32	34	29		38			38			44			44		18.9	37	14

Pad Diameters **ø10, ø13, ø16**

Bellows style

Model	øA	øB	øC	F: M5			F: M6			F: Rc(PT) 1/8			øK	øL	Y
				D	E	G	D	E	G	D	E	G			
ZPT10B	10	12	16	5	25	8	6	25	8	6.2	31	12	5.5	13.8	5.5
ZPT13B	13	15	18.5	5	27.5	8	6	27.5	8	6.2	33.5	12	8.7	19	7.5
ZPT16B	16	18	20	5	29	8	6	29	8	6.2	35	12	9.9	21	8.5

Pad Diameters **ø40, ø50**

Bellows style

Model	øA	øB	øC	F: M6			F: M8			F: Rc(PT) 1/8			E	øK	øL	Y
				D	D	D	D	D	D							
ZPT40B	40	43	34	6	6	8	6.2	47.5	24.4	48	16					
ZPT50B	50	53	38	6	6	8	6.2	51.5	32.4	57	19					

- ZX
- ZR
- ZM
- ZY
- ZH
- ZU
- ZL
- ZF
- ZP
- ZCU
- CYV
- Vacuum related

Series ZPT

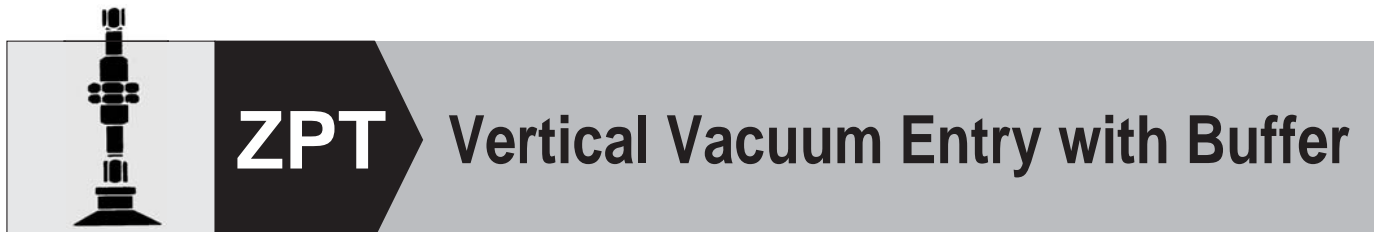

Specifications

Vacuum entry direction		Vertical			
		Connection	Female thread	Barb fitting	One-touch fitting
Vacuum entry	Thread dia.	ø2 to ø8	M3 M5	ø4 Nylon tube ø4 Urethane tube	ø4 tube ø6 tube
		ø10 to ø32	M5	ø6 Nylon tube ø6 Urethane tube	ø4 tube ø6 tube
		ø40 to ø50	M5 Rc (PT) 1/8	ø6 Nylon tube ø6 Urethane tube	ø6 tube ø8 tube
Mounting		ø2 to ø8	M8 X 1 Male thread		
		ø10 to ø32	M10 X 1 Male thread		
		ø40 to ø50	M14 X 1 Male thread		
Buffer style		Rotating (J)/Non-rotating (K)			
Buffer stroke		For ø2 to ø8 — 6, 10, 15, 25mm			
		For ø10 to ø32 — 10, 20, 30, 40, 50mm			
		For ø40, ø50 — 10, 20, 30, 50mm			

Spring Reactive Force

N

Pad dia. (mm)	0 stroke	Stroke end
ø2 to ø8	0.8N	1.2N
ø10 to ø32	1.0N	3.0N
ø40, ø50	2.0N	5.0N

Pad Style

Pad style	Flat	Flat with ribs	Deep	Bellows
Pad dia. ø(mm)	2, 4, 6, 8, 10, 13, 16, 20, 25, 32, 40, 50	10, 13, 16, 20, 25, 32, 40, 50	10, 16, 25, 40	6, 8, 10, 13, 16, 20, 25, 32, 40, 50
Material (colour)	NBR (Black), Silicon (White), Urethane rubber (Brown)/ Fluorine rubber (Black with green mark) Conductive NBR (Black with one white mark), Conductive silicon rubber (Black with two white marks)			
Hardness	NBR (50°), Silicon (40°), Urethane rubber/Fluorine rubber (60°) Conductive NBR (50°), Conductive silicon rubber (50°)			

Weight Table

(g)

Stroke	Pad style Connection Model	Flat/Flat with ribs							Deep				Bellows								
		Female thread			One-touch fitting				Barb fitting N□U□	Female thread			Barb fitting N□U□	Female thread			One-touch fitting				Barb fitting N□U□
		B3	B5	B01	04	06	08	B5		B01	04	06		08	B3	B5	B01	04	06	08	
6	ZPT 02 to 08	22	24	—	26	27	—	22	—	—	—	—	—	22	24	—	26	27	—	22	
10	ZPT 10 to 16	—	26	—	29	30	—	25	27	—	29	30	—	25	—	27	—	30	31	—	26
10	ZPT 20 25	—	29	—	31	33	—	27	30	—	32	33	—	28	—	31	—	34	35	—	30
	ZPT 32	—	57	—	33	34	—	30	—	—	—	—	—	—	36	—	38	39	—	34	
10	ZPT 40	—	129	132	—	133	141	129	131	134	—	134	143	129	—	141	144	—	145	153	140
	ZPT 50	—	135	138	—	139	147	133	—	—	—	—	—	—	—	148	151	—	152	160	147

Weight by Stroke

(g)

Stroke (mm)	10	15	20	25	30	40	50
ZPT02 to 08	+6	+7	—	+8	—	—	—
ZPT10 to 25	—	—	+11	—	+13	+23	+24
ZPT40, 50	—	—	+38	—	+40	—	+67



P.3.9-64 to 3.9-69

Vertical Vacuum Entry with Buffer Series ZPT

How to Order

**Series ZPT
with buffer**

ZPT

16

U

GS

K

20

06

A10

Pad dia. (mm)

02	ø2
04	ø4
06	ø6
08	ø8
10	ø10
13	ø13
16	ø16
20	ø20
25	ø25
32	ø32
40	ø40
50	ø50

Mounting thread (Male thread) diameter
(Refer to Table ③ for applications.)

Vacuum entry
(Refer to Table ③ for applications.)

Buffer stroke
(Refer to Table ② for applications.)

Buffer style

J	Rotating
K	Non-rotating

Material

N	NBR
S	Silicon rubber
U	Urethane rubber
F	Fluorine rubber
GN*	Conductive NBR (ø2 to ø16)
GS*	Conductive silicon rubber (ø2 to ø16)

*ø20 and larger are manufactured upon receipt of order.

Pad style
(Refer to Table ① for applications.)

U	Flat
C	Flat with ribs
D	Deep
B	Bellows

- ZX
- ZR
- ZM
- ZY
- ZH
- ZU
- ZL
- ZF
- ZP
- ZCU
- CYV

Vacuum related

Table ① Pad Dia. /Pad Style

Style	Dia. (mm)											
	2	4	6	8	10	13	16	20	25	32	40	50
Flat	●	●	●	●	●	●	●	●	●	●	●	●
Flat with ribs	—	—	—	—	●	●	●	●	●	●	●	●
Deep	—	—	—	—	●	—	●	—	●	—	●	—
Bellows	—	—	●	●	●	●	●	●	●	●	●	●

Table ② Pad Dia. /Stroke

Stroke	Dia. (mm)											
	2	4	6	8	10	13	16	20	25	32	40	50
6mm	●	●	●	●	—	—	—	—	—	—	—	—
10mm	●	●	●	●	●	●	●	●	●	●	●	●
15mm	●	●	●	●	—	—	—	—	—	—	—	—
20mm	—	—	—	—	●	●	●	●	●	●	●	●
25mm	●	●	●	●	—	—	—	—	—	—	—	—
30mm	—	—	—	—	●	●	●	●	●	●	●	●
40mm	—	—	—	—	●	●	●	●	●	●	—	—
50mm	—	—	—	—	●	●	●	●	●	●	●	●

Table ③ Vacuum Entry/Mounting Thread Dia.

	Symbol	Thread dia. /Port size	ø2 to ø8	ø10 to ø32	ø40, ø50	
			●	—	●	
Vacuum entry	Female thread	B3	M3	●	—	
		B5	M5	●	●	
		B01	Rc(PT) 1/8	—	—	●
	Barb fitting	N4	ø4 Nylon tube	●	—	—
		N6	ø6 Nylon tube	—	●	●
		U4	ø4 Urethane tube	●	—	—
One-touch fitting	U6	ø6 Urethane tube	—	●	●	
	04	ø4 tube	●	●	—	
	06	ø6 tube	●	●	●	
Mounting	Male thread	08	ø8 tube	—	—	
		A8	M8 X 1	●	—	
		A10	M10 X 1	—	●	—
		A14	M14 X 1	—	—	

Series ZPT

Connection	Female Thread (Buffer)	Pad Style	Flat
Vacuum Entry	Vertical	Mounting	Buffer Body

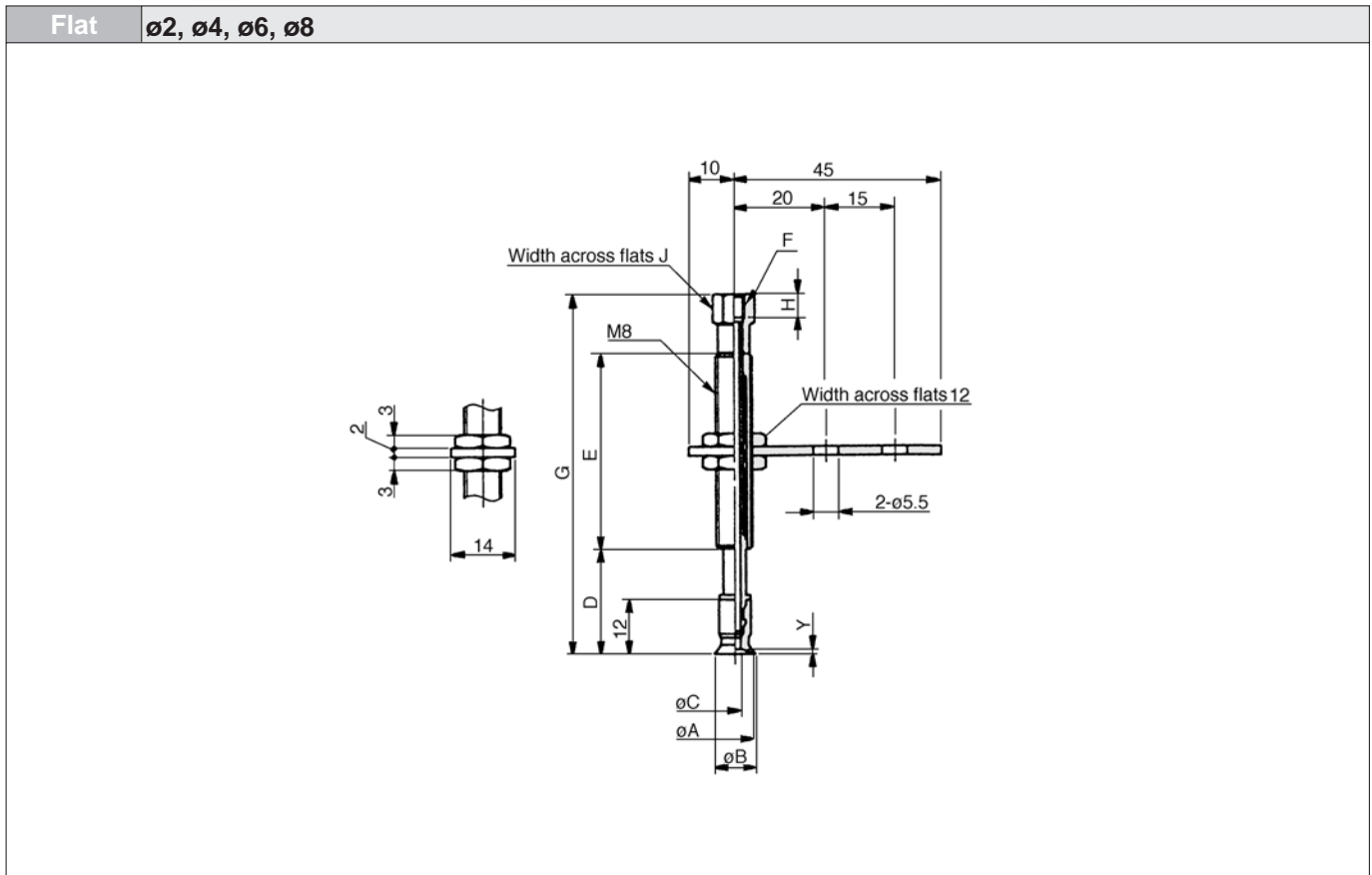

Flat style

Model	A	B	C	Y
ZPT02U□□□□-B□-A8	2	2.6	1.2	0.8
ZPT04U□□□□-B□-A8	4	4.8	1.6	
ZPT06U□□□□-B□-A8	6	7	2.5	1
ZPT08U□□□□-B□-A8	8	9		

Dimensions by stroke

Model	D	E	F: M3			F: M5		
			G	H	J	G	H	J
ZPT□□U□□□ 6-B□-A8	18	15	44	3	6	46	5	8
ZPT□□U□□□10-B□-A8	23	43	77			79		
ZPT□□U□□□15-B□-A8	28		82	92	84			
ZPT□□U□□□25-B□-A8	38	94	94					

Vertical Vacuum Entry with Buffer Series ZPT

Connection	Female Thread (Buffer)	Pad Style	Flat/Flat with Ribs/Deep
Vacuum Entry	Vertical	Mounting	Buffer Body

Flat/Flat with ribs	ø10, ø13, ø16	Deep	ø10, ø16
----------------------------	----------------------	-------------	-----------------

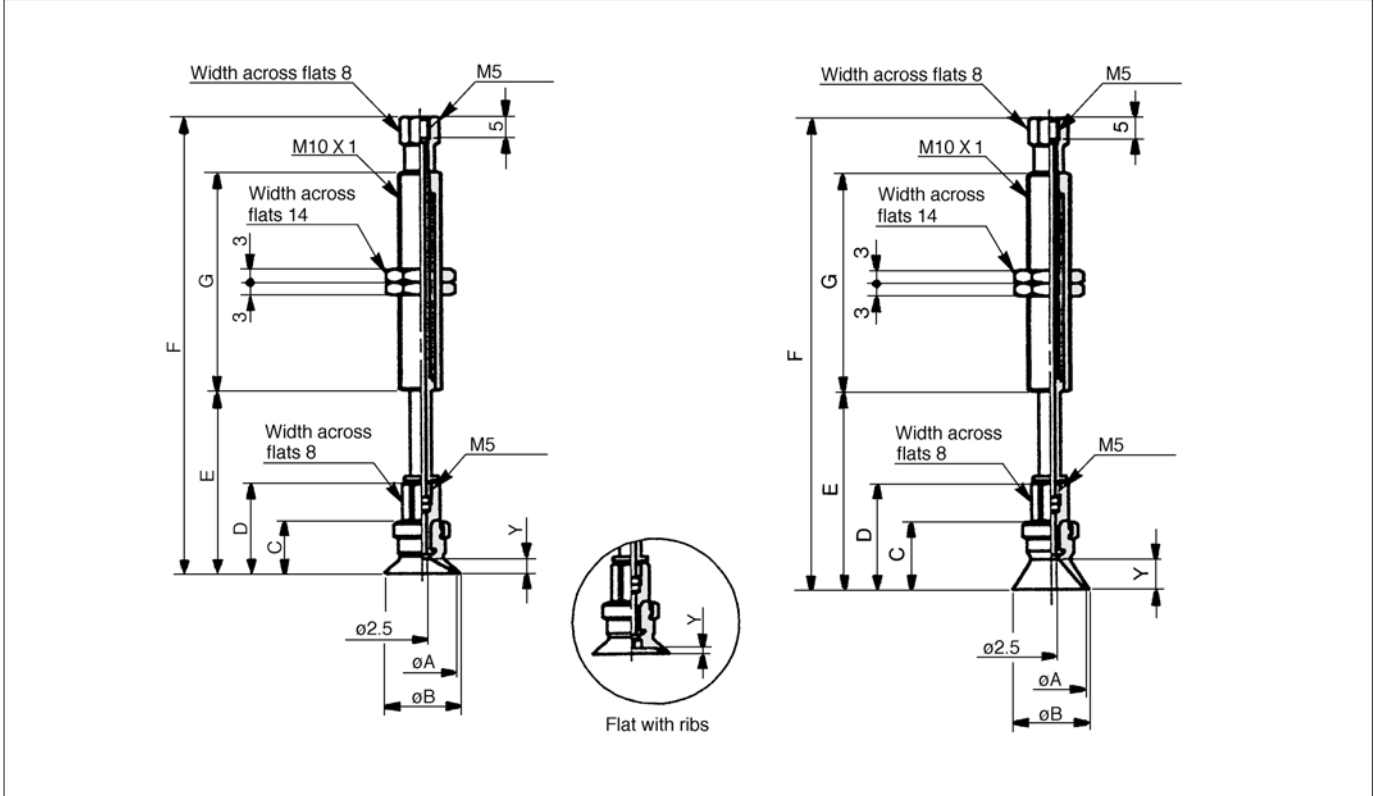

- ZX
- ZR
- ZM
- ZY
- ZH
- ZU
- ZL
- ZF
- ZP**
- ZCU
- CYV
- Vacuum related

Flat style/Flat with ribs

Model	A	B	C	D	Y	
					Flat	Flat with ribs
ZPT10 _C □□□□□-B5-A10	10	12	12	21	3	1.7
ZPT13 _C □□□□□-B5-A10	13	15				1.8
ZPT16 _C □□□□□-B5-A10	16	18	12.5	21.5	3.5	1.2

Dimensions by stroke

Model	ø10, ø13		ø16		G
	E	F	E	F	
ZPT□□ _C □□□□□10-B5-A10	32.5	68.5	33	69	51
ZPT□□ _C □□□□□20-B5-A10	42.5	106.5	43	107	
ZPT□□ _C □□□□□30-B5-A10	52.5	116.5	53	117	
ZPT□□ _C □□□□□40-B5-A10	62.5	152.5	63	153	77
ZPT□□ _C □□□□□50-B5-A10	72.5	162.5	73	163	

Deep style

Model	A	B	C	D	Y
ZPT10D□□□□□-B5-A10	10	12	15	24	6
ZPT16D□□□□□-B5-A10	16	18	16	25	7

Dimensions by stroke

Model	ø10		ø16		G
	E	F	E	F	
ZPT□□D□□□□□10-B5-A10	35.5	71.5	36.5	72.5	51
ZPT□□D□□□□□20-B5-A10	45.5	109.5	46.5	110.5	
ZPT□□D□□□□□30-B5-A10	55.5	119.5	56.5	120.5	
ZPT□□D□□□□□40-B5-A10	65.5	155.5	66.5	156.5	77
ZPT□□D□□□□□50-B5-A10	75.5	165.5	76.5	166.5	

Series ZPT

Connection	Female Thread (Buffer)	Pad Style	Flat/Flat with Ribs/Deep
Vacuum Entry	Vertical	Mounting	Buffer Body

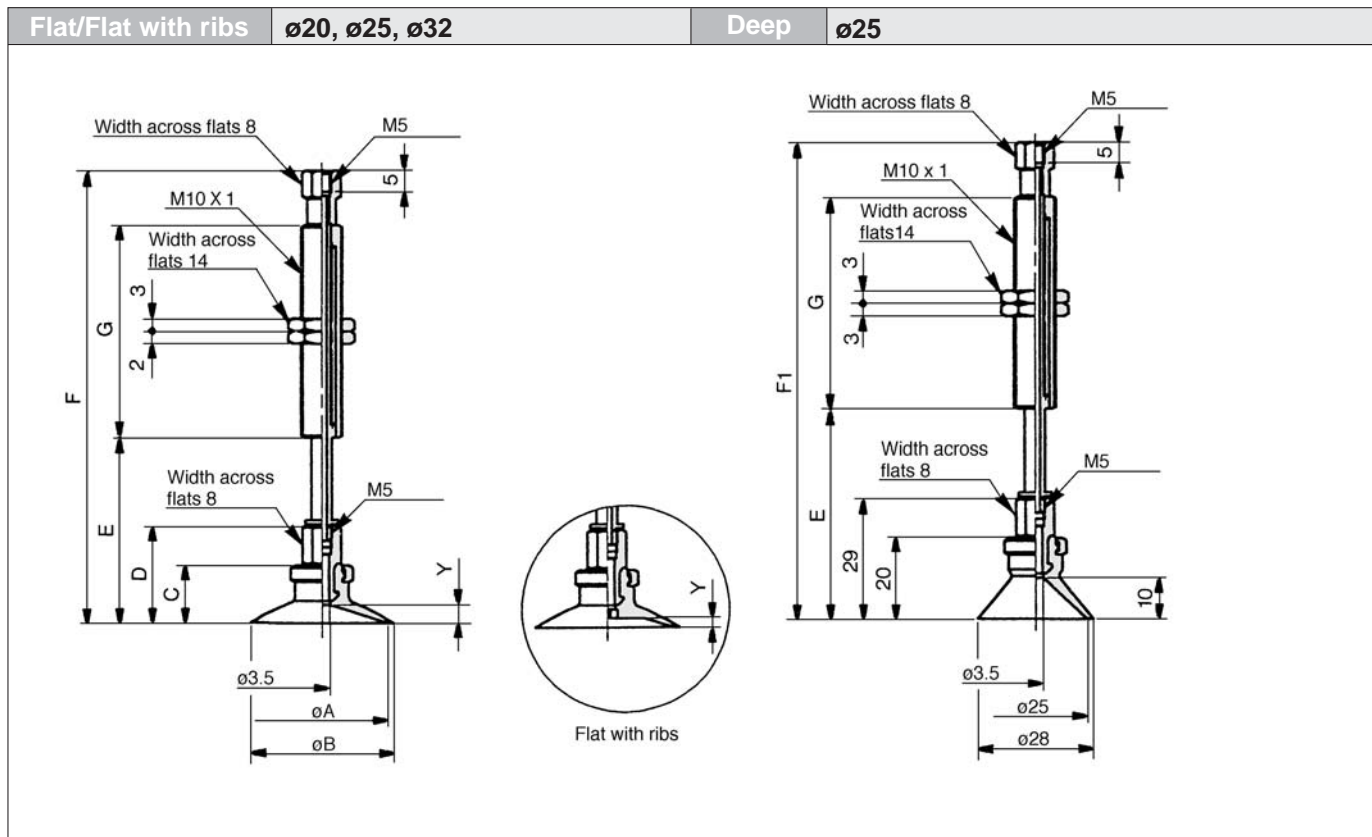

Flat style/Flat with ribs

Model	A	B	C	D	Y	
					Flat	Flat with ribs
ZPT20 ^U / _C □□□□□-B5-A10	20	23	14	23	4	1.7
ZPT25 ^U / _C □□□□□-B5-A10	25	28				1.8
ZPT32 ^U / _C □□□□□-B5-A10	32	35	14.5	23.5	4.5	2.3

Deep style

Model	E	F	G
ZPT25D□□□10-B5-A10	40.5	76.5	23
ZPT25D□□□20-B5-A10	50.5	114.5	51
ZPT25D□□□30-B5-A10	60.5	124.5	
ZPT25D□□□40-B5-A10	70.5	160.5	77
ZPT25D□□□50-B5-A10	80.5	170.5	

Dimensions by stroke

Model	$\varnothing 20, \varnothing 25$		$\varnothing 32$		G
	E	F	E	F	
ZPT□□ ^U / _C □□□□□10-B5-A10	34.5	70.5	35	71	23
ZPT□□ ^U / _C □□□□□20-B5-A10	44.5	108.5	45	109	51
ZPT□□ ^U / _C □□□□□30-B5-A10	54.5	118.5	55	119	
ZPT□□ ^U / _C □□□□□40-B5-A10	64.5	154.5	65	155	77
ZPT□□ ^U / _C □□□□□50-B5-A10	74.5	164.5	75	165	

Vertical Vacuum Entry with Buffer Series ZPT

Connection	Female Thread (Buffer)	Pad Style	Flat/Flat with Ribs/Deep
Vacuum Entry	Vertical	Mounting	Buffer Body

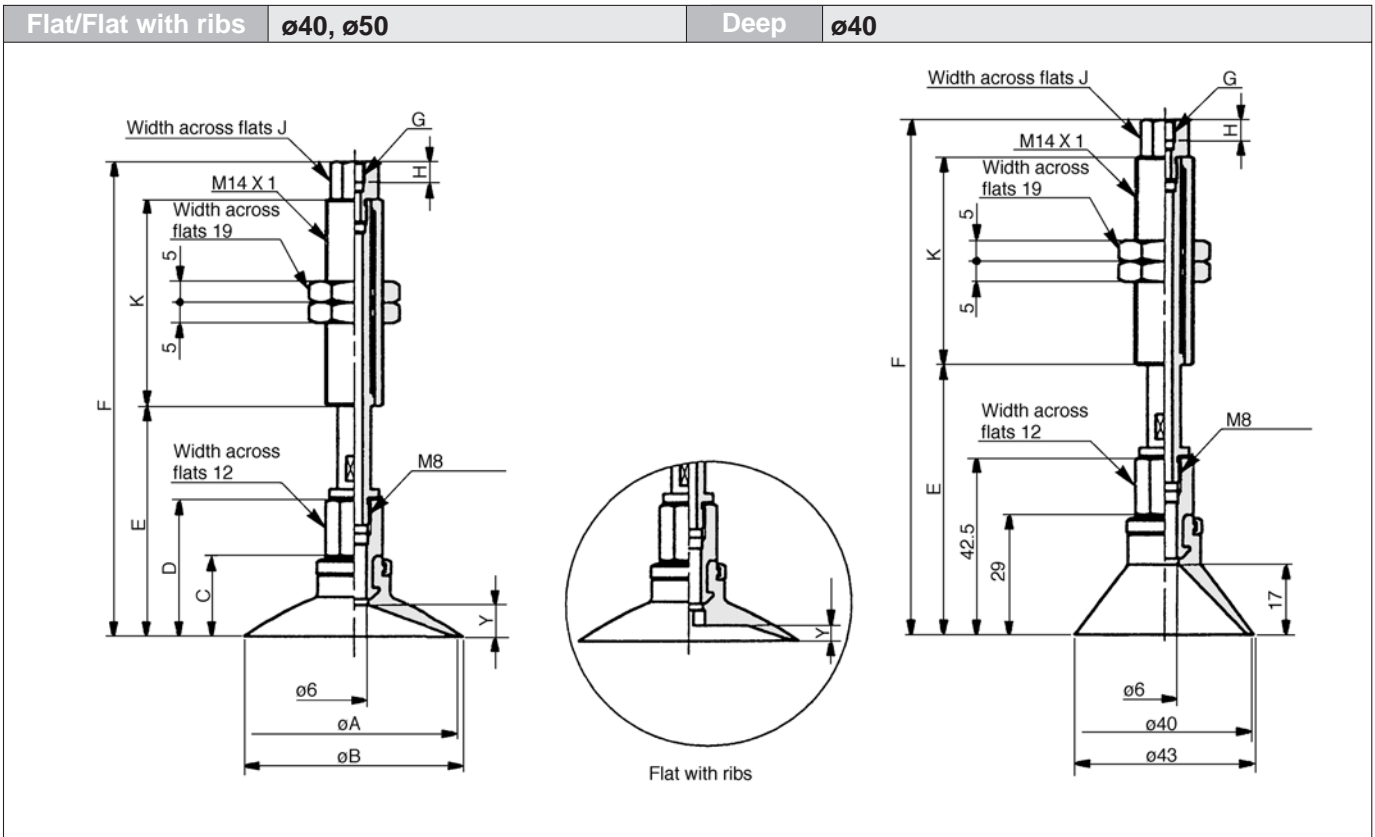

- ZX
- ZR
- ZM
- ZY
- ZH
- ZU
- ZL
- ZF
- ZP**
- ZCU
- CYV
- Vacuum related

Flat style/Flat with ribs

Model	A	B	C	D	Y	
					Flat	Flat with ribs
ZPT40 _C □□□□□-B□□-A14	40	43	18.5	32	6.5	3.3
ZPT50 _C □□□□□-B□□-A14	50	53	19.5	33	7.5	3.8

Dimensions by stroke

Model	E		G: M5 X 0.8			G: Rc(PT)1/8			K		
	$\phi 40$	$\phi 50$	F		H	J	F				
			$\phi 40$	$\phi 50$			$\phi 40$	$\phi 50$			
ZPT□□ _C □□□□□10-B□□-A14	44.5	45.5	109.5	110.5	5	10	111	112	50		
ZPT□□ _C □□□□□20-B□□-A14	54.5	55.5	113.5	114.5			116.5	117.5		6.2	13
ZPT□□ _C □□□□□30-B□□-A14	64.5	65.5	123.5	124.5			126.5	127.5			
ZPT□□ _C □□□□□50-B□□-A14	84.5	85.5	168.5	169.5			171.5	172.5		75	

Deep style

Model	E	G: M5 X 0.8			G: Rc(PT)1/8			K	
		F	H	J	F		H		J
					$\phi 40$	$\phi 50$			
ZPT40D□□□□10-B□□-A14	55	120	5	10	121.5	6.2	13	50	
ZPT40D□□□□20-B□□-A14	65	124			127				
ZPT40D□□□□30-B□□-A14	75	134			137				
ZPT40D□□□□50-B□□-A14	95	179			182				

Series ZPT

Connection	Female Thread (Buffer)	Pad Style	Bellows
Vacuum Entry	Vertical	Mounting	Buffer Body

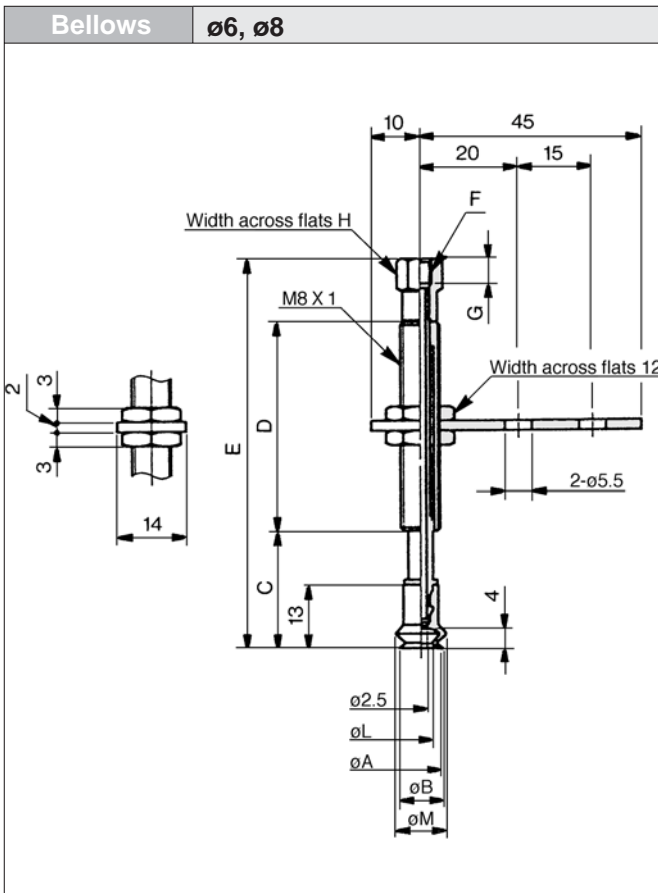

Bellows style

Model	A	B	L	M
ZPT06B□□□□□-B□-A8	6	7	3.3	9.1
ZPT08B□□□□□-B□-A8	8	9	4.7	10.1

Dimensions by stroke

Model	C	D	F: M3			F: M5		
			E	G	H	E	G	H
ZPT□□B□□□□ 6-B□-A8	19	15	45			47		
ZPT□□B□□□□10-B□-A8	24		78	3	6	80	5	8
ZPT□□B□□□□15-B□-A8	29	43	83			85		
ZPT□□B□□□□25-B□-A8	39		93			95		

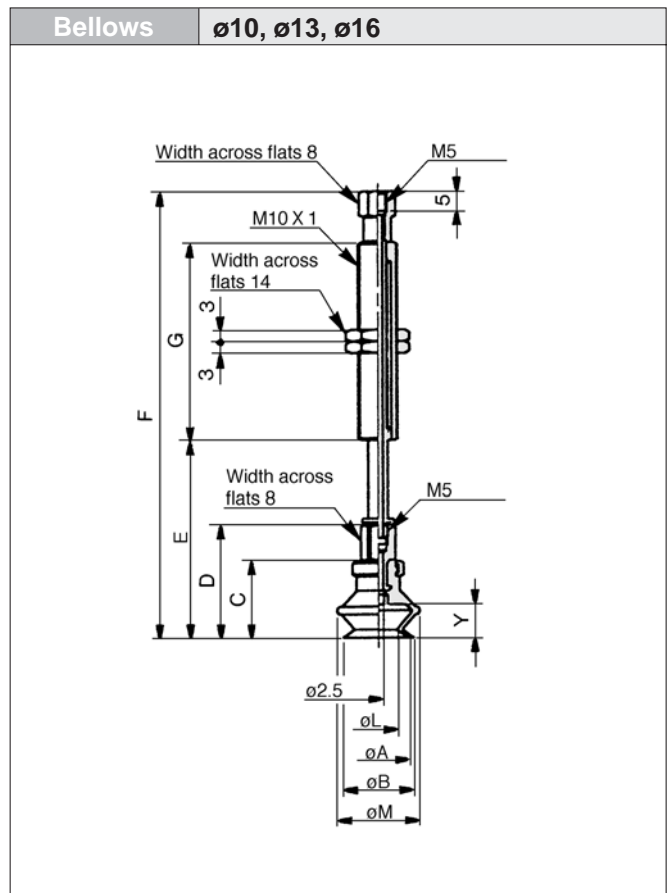

Bellows style

Model	A	B	C	D	L	M	Y
ZPT10B□□□□□-B5-A10	10	12	16	25	5.5	13.8	5.5
ZPT13B□□□□□-B5-A10	13	15	18.5	27.5	8.7	19	7.5
ZPT16B□□□□□-B5-A10	16	18	20	29	9.9	21	8.5

Dimensions by stroke

Model	$\phi 10$		$\phi 13$		$\phi 16$		G
	E	F	E	F	E	F	
ZPT□□B□□□□10-B5-A10	36.5	72.5	39	75	40.5	76.5	23
ZPT□□B□□□□20-B5-A10	46.5	110.5	49	113	50.5	114.5	51
ZPT□□B□□□□30-B5-A10	56.5	120.5	59	123	60.5	124.5	
ZPT□□B□□□□40-B5-A10	66.5	156.5	69	159	70.5	160.5	
ZPT□□B□□□□50-B5-A10	76.5	166.5	79	169	80.5	170.5	77

Vertical Vacuum Entry with Buffer Series ZPT

Connection	Female Thread (Buffer)	Pad Style	Bellows
Vacuum Entry	Vertical	Mounting	Buffer Body

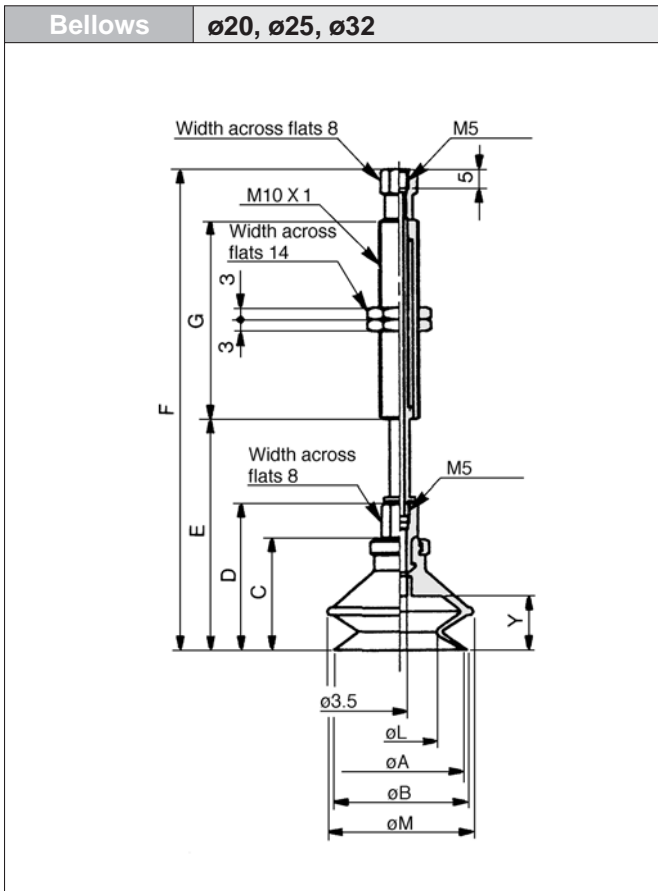

Bellows style

Model	A	B	C	D	L	M	Y
ZPT20B□□□□□-B5-A10	20	22	23.5	32.5	12.4	25	10.5
ZPT25B□□□□□-B5-A10	25	27	24	33	15.6	28	
ZPT32B□□□□□-B5-A10	32	34	29	38	18.9	37	

Dimensions by stroke

Model	$\phi 20$		$\phi 25$		$\phi 32$		G
	E	F	E	F	E	F	
ZPT□□B□□□□10-B5-A10	44	80	44.5	80.5	49.5	85.5	23
ZPT□□B□□□□20-B5-A10	54	118	54.5	118.5	59.5	123.5	51
ZPT□□B□□□□30-B5-A10	64	128	64.5	128.5	69.5	133.5	
ZPT□□B□□□□40-B5-A10	74	164	74.5	164.5	79.5	169.5	77
ZPT□□B□□□□50-B5-A10	84	174	84.5	174.5	89.5	179.5	

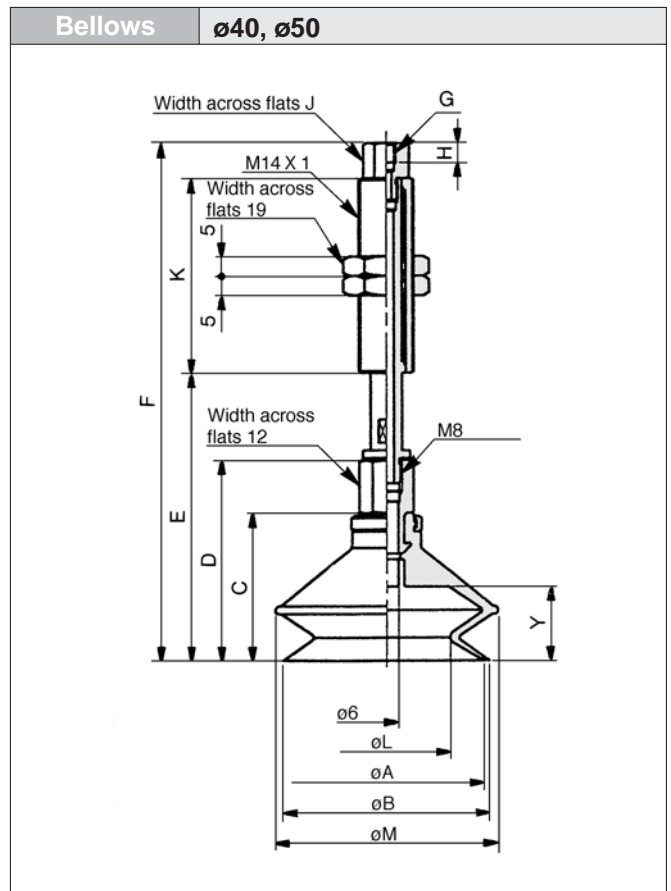

Bellows style

Model	A	B	C	D	L	M	Y
ZPT40B□□□□□-B□□-A14	40	43	34	47.5	24.4	48	16
ZPT50B□□□□□-B□□-A14	50	53	38	51.5	32.4	57	19

Dimensions by stroke

Model	E		G: M5				G: Rc(PT) ^{1/8}				K
	$\phi 40$	$\phi 50$	F		H	J	F		H	J	
			$\phi 40$	$\phi 50$			$\phi 40$	$\phi 50$			
ZPT□□B□□□□10-B□□-A14	60	64	125	129	5	10	126.5	130.5	6.2	13	50
ZPT□□B□□□□20-B□□-A14	70	74	129	133			132	136			
ZPT□□B□□□□30-B□□-A14	80	84	139	143			142	146			
ZPT□□B□□□□50-B□□-A14	100	104	184	188			187	191			
							187	191			

- ZX
- ZR
- ZM
- ZY
- ZH
- ZU
- ZL
- ZF
- ZP**
- ZCU
- CYV
- Vacuum related

Series ZPT

Connection	One-touch Fitting (Buffer)	Pad Style	Flat/Flat with Ribs/Deep
Vacuum Entry	Vertical	Mounting	Buffer Body

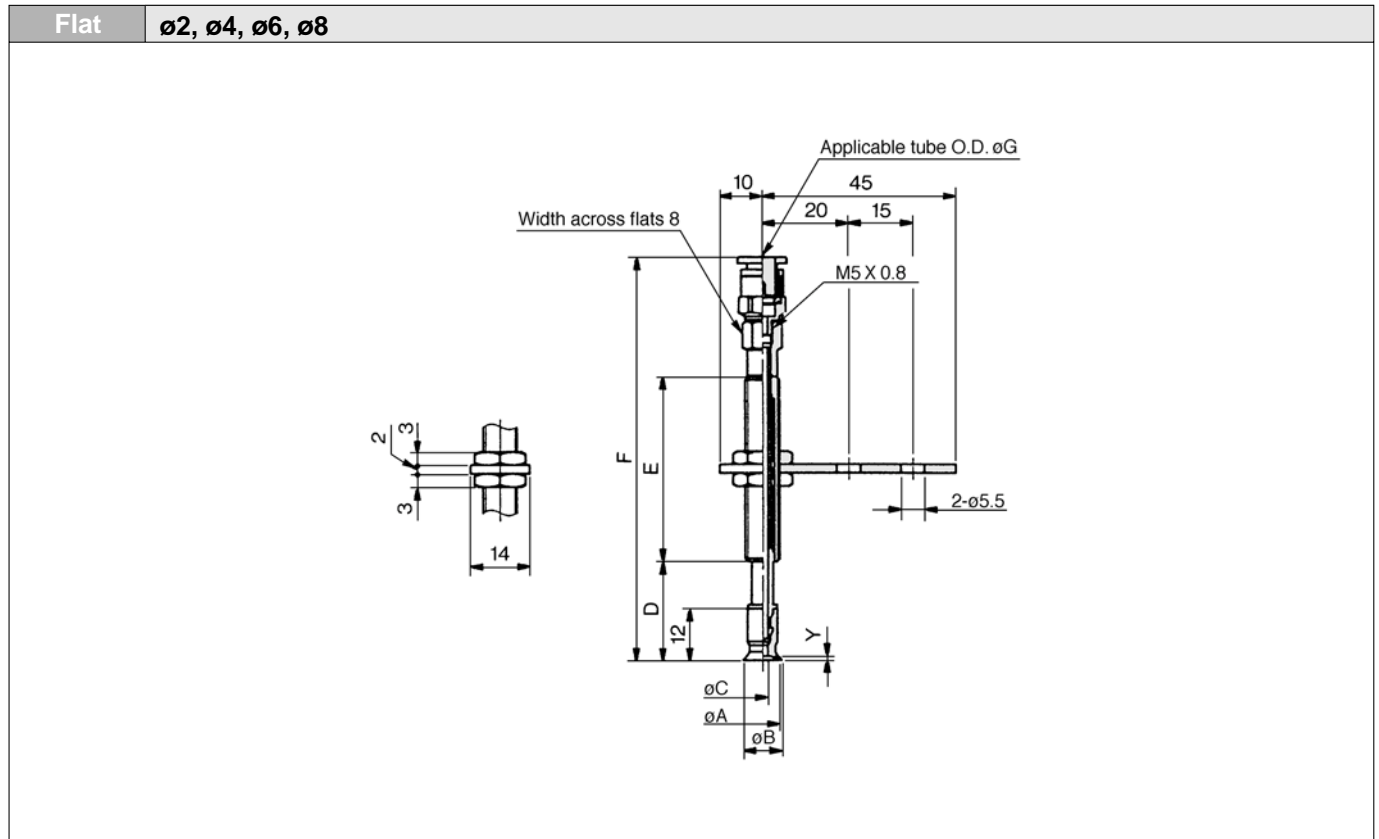

Flat style

Model	A	B	C	Y
ZPT02U□□□□□-0□-A8	2	2.6	1.2	0.8
ZPT04U□□□□□-0□-A8	4	4.8	1.6	
ZPT06U□□□□□-0□-A8	6	7	2.5	
ZPT08U□□□□□-0□-A8	8	9		

Dimensions by stroke

Model	D	E	F	
			G: $\varnothing 4$	G: $\varnothing 6$
ZPT□□U□□□□ 6-0□-A8	18	15	60	61
ZPT□□U□□□□ 10-0□-A8	23	43	93	94
ZPT□□U□□□□ 15-0□-A8	28		98	99
ZPT□□U□□□□ 25-0□-A8	38		108	109

Vertical Vacuum Entry with Buffer Series ZPT

Connection	One-touch Fitting (Buffer)	Pad Style	Flat/Flat with Ribs/Deep
Vacuum Entry	Vertical	Mounting	Buffer Body

Flat/Flat with ribs	ø10, ø13, ø16	Deep	ø10, ø16
---------------------	---------------	------	----------

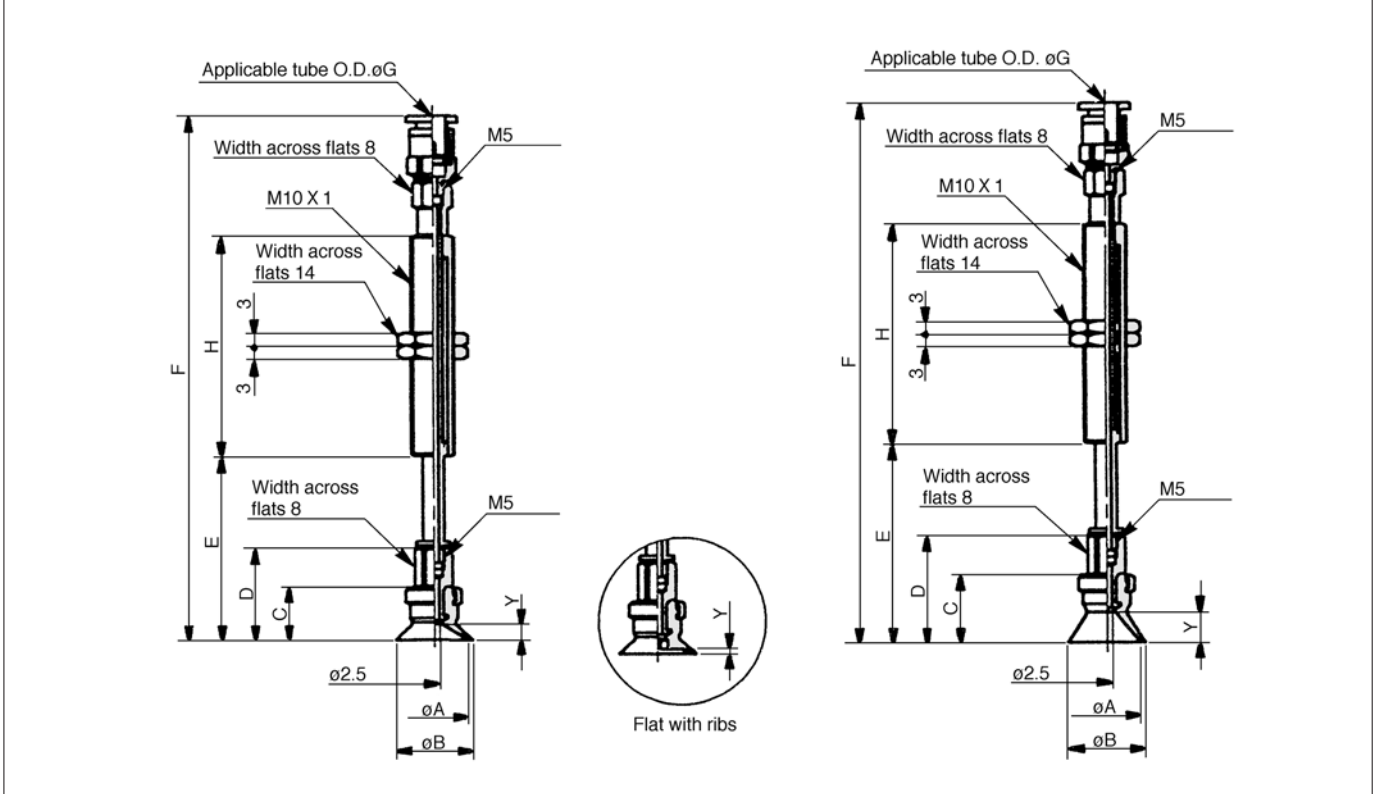

Flat style/Flat with ribs

Model	A	B	C	D	Y	
					Flat	Flat with ribs
ZPT10 $\frac{U}{C}$ □□□□□-0□-A10	10	12	12	21	3	1.7
ZPT13 $\frac{U}{C}$ □□□□□-0□-A10	13	15				1.8
ZPT16 $\frac{U}{C}$ □□□□□-0□-A10	16	18	12.5	21.5	3.5	1.2

Dimensions by stroke

Model	ø10, ø13			ø16			H
	E	F		E	F		
		G: ø4	G: ø6		G: ø4	G: ø6	
ZPT□□ $\frac{U}{C}$ □□□□10-0□-A10	32.5	82.5	83.5	33	83	84	23
ZPT□□ $\frac{U}{C}$ □□□□20-0□-A10	42.5	120.5	121.5	43	121	122	51
ZPT□□ $\frac{U}{C}$ □□□□30-0□-A10	52.5	130.5	131.5	53	131	132	
ZPT□□ $\frac{U}{C}$ □□□□40-0□-A10	62.5	166.5	167.5	63	167	168	77
ZPT□□ $\frac{U}{C}$ □□□□50-0□-A10	72.5	176.5	177.5	73	177	178	

Deep style

Model	A	B	C	D	Y
ZPT10D□□□□□-0□-A10	10	12	15	24	6
ZPT16D□□□□□-0□-A10	16	18	16	25	7

Dimensions by stroke

Model	ø10			ø16			H
	E	F		E	F		
		G: ø4	G: ø6		G: ø4	G: ø6	
ZPT□□D□□□□10-0□-A10	35.5	85.5	86.5	36.5	86.5	87.5	23
ZPT□□D□□□□20-0□-A10	45.5	123.5	124.5	46.5	124.5	125.5	51
ZPT□□D□□□□30-0□-A10	55.5	133.5	134.5	56.5	134.5	135.5	
ZPT□□D□□□□40-0□-A10	65.5	169.5	170.5	66.5	170.5	171.5	77
ZPT□□D□□□□50-0□-A10	75.5	179.5	180.5	76.5	180.5	181.5	

Series ZPT

Connection	One-touch Fitting (Buffer)	Pad Style	Flat/Flat with Ribs/Deep
Vacuum Entry	Vertical	Mounting	Buffer Body

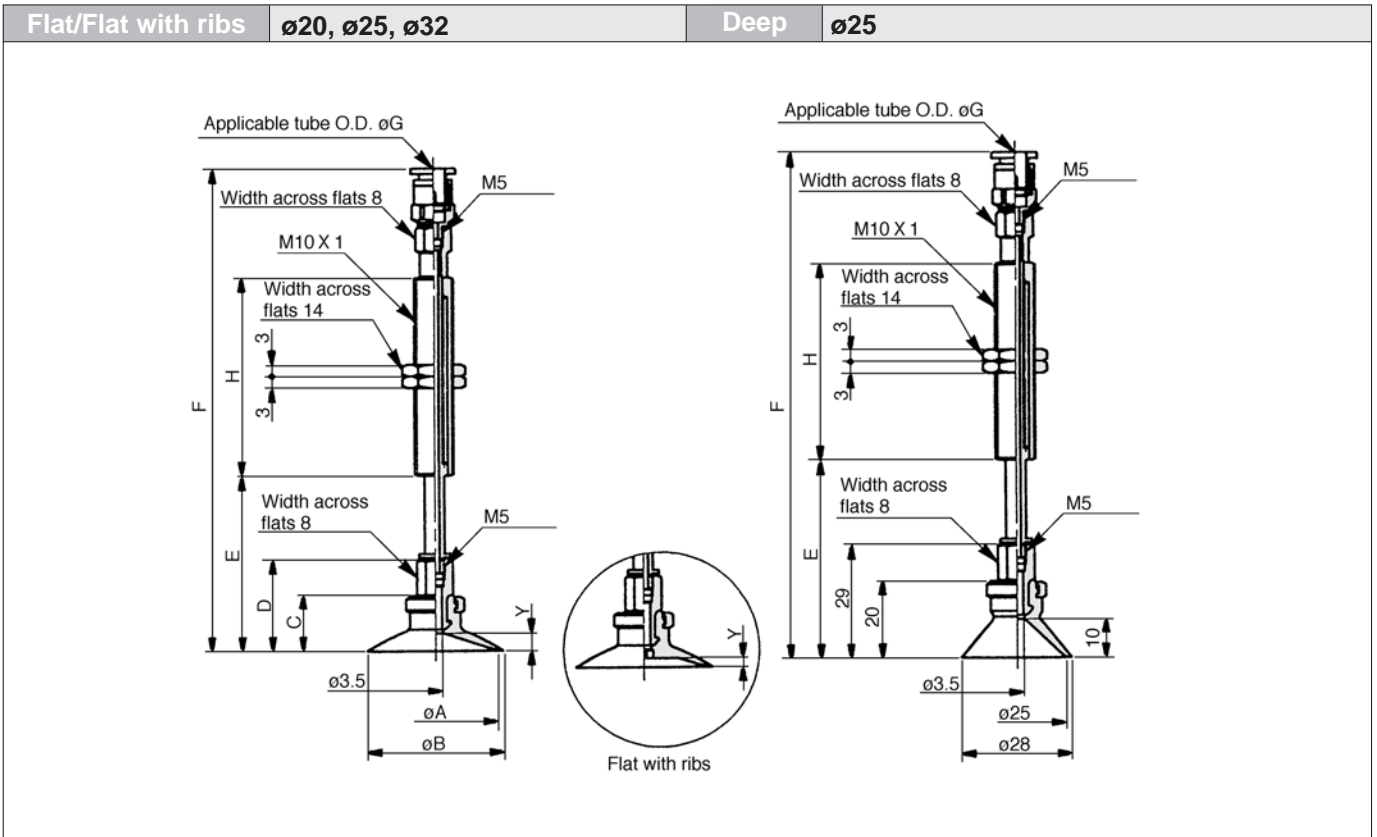

Flat style/Flat with ribs

Model	A	B	C	D	Y	
					Flat	Flat with ribs
ZPT20 ^U □□□□□-0□-A10	20	23	14	23	4	1.7
ZPT25 ^U □□□□□-0□-A10	25	28				1.8
ZPT32 ^U □□□□□-0□-A10	32	35	14.5	23.5	4.5	2.3

Dimensions by stroke

Model	ø20, ø25			ø32			H
	E	F		E	F		
		G: ø4	G: ø6		G: ø4	G: ø6	
ZPT□□ ^U □□□□□10-0□-A10	34.5	84.5	85.5	35	85	86	23
ZPT□□ ^U □□□□□20-0□-A10	44.5	122.5	123.5	45	123	124	51
ZPT□□ ^U □□□□□30-0□-A10	54.5	132.5	133.5	55	133	134	
ZPT□□ ^U □□□□□40-0□-A10	64.5	168.5	169.5	65	169	170	77
ZPT□□ ^U □□□□□50-0□-A10	74.5	178.5	179.5	75	179	180	

Deep style

Model	E	F		H
		G: ø4	G: ø6	
ZPT25D□□□□10-0□-A10	40.5	90.5	91.5	23
ZPT25D□□□□20-0□-A10	50.5	128.5	129.5	51
ZPT25D□□□□30-0□-A10	60.5	138.5	139.5	
ZPT25D□□□□40-0□-A10	70.5	174.5	175.5	77
ZPT25D□□□□50-0□-A10	80.5	184.5	185.5	

Vertical Vacuum Entry with Buffer Series ZPT

Connection	One-touch Fitting (Buffer)	Pad Style	Flat/Flat with Ribs/Deep
Vacuum Entry	Vertical	Mounting	Buffer Body

Flat/Flat with ribs	ø40, ø50	Deep	ø40
----------------------------	-----------------	-------------	------------

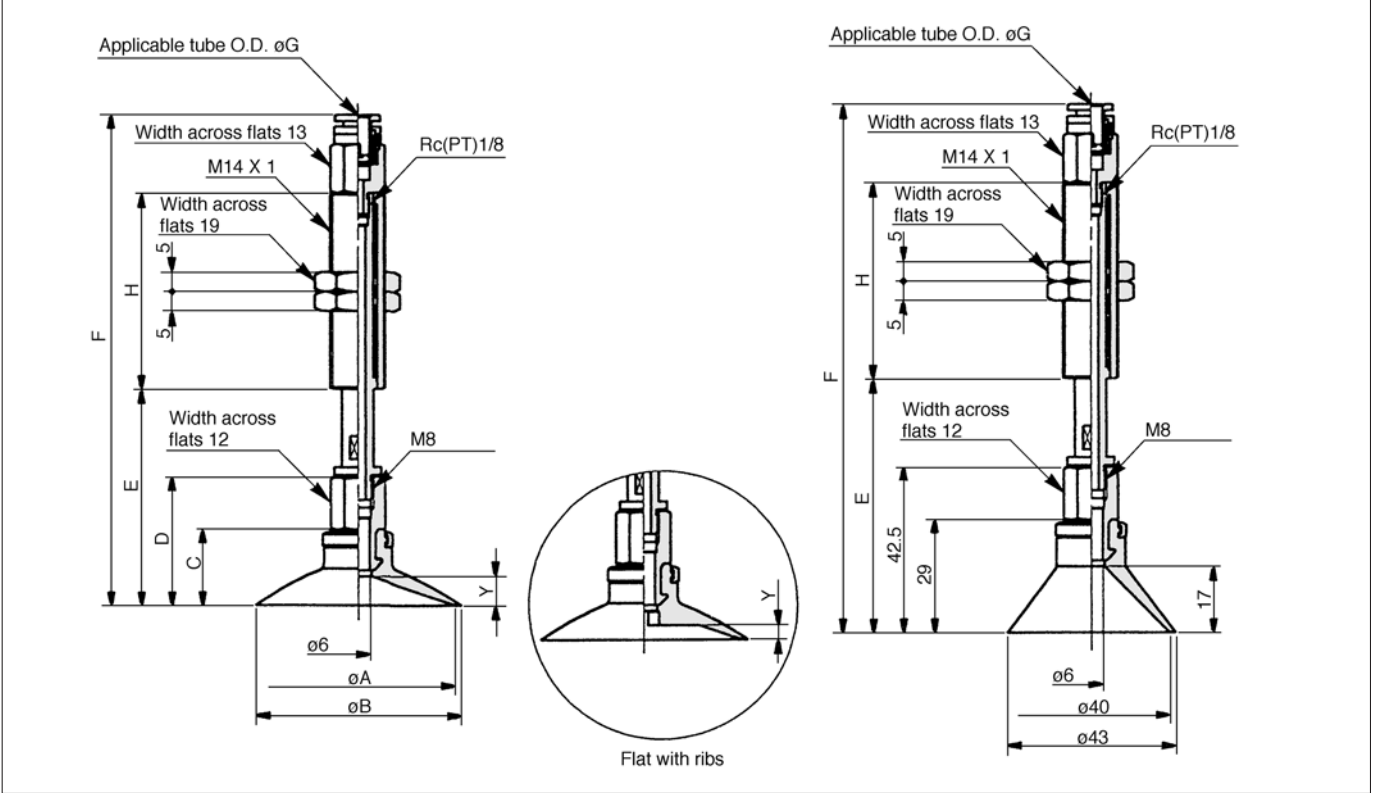

- ZX
- ZR
- ZM
- ZY
- ZH
- ZU
- ZL
- ZF
- ZP**
- ZCU
- CYV
- Vacuum related

Flat style/Flat with ribs

Model	A	B	C	D	Y	
					Flat	Flat with ribs
ZPT40 ^U _C □□□□-0□-A14	40	43	18.5	32	6.5	3.3
ZPT50 ^U _C □□□□-0□-A14	50	53	19.5	33	7.5	3.8

Dimensions by stroke

Model	ø40		ø50		H		
	E	F		E		F	
		G: ø6	G: ø8			G: ø6	G: ø8
ZPT□□ ^U _C □□□□10-0□-A14	44.5	129.5	135	45.5	130.5	136	
ZPT□□ ^U _C □□□□20-0□-A14	54.5	124.4	129.4	55.5	125.4	130.4	
ZPT□□ ^U _C □□□□30-0□-A14	64.5	134.4	139.4	65.5	135.4	140.4	
ZPT□□ ^U _C □□□□50-0□-A14	84.5	179.4	184.4	85.5	180.4	185.4	

Deep style

Model	E	F		H
		G: ø6	G: ø8	
ZPT40D□□□□10-0□-A14	55	140	145.5	50
ZPT40D□□□□20-0□-A14	65	134.9	139.9	
ZPT40D□□□□30-0□-A14	75	144.9	149.9	
ZPT40D□□□□50-0□-A14	95	189.9	194.9	

Series ZPT

Connection	One-touch Fitting (Buffer)	Pad Style	Bellows
Vacuum Entry	Vertical	Mounting	Buffer Body

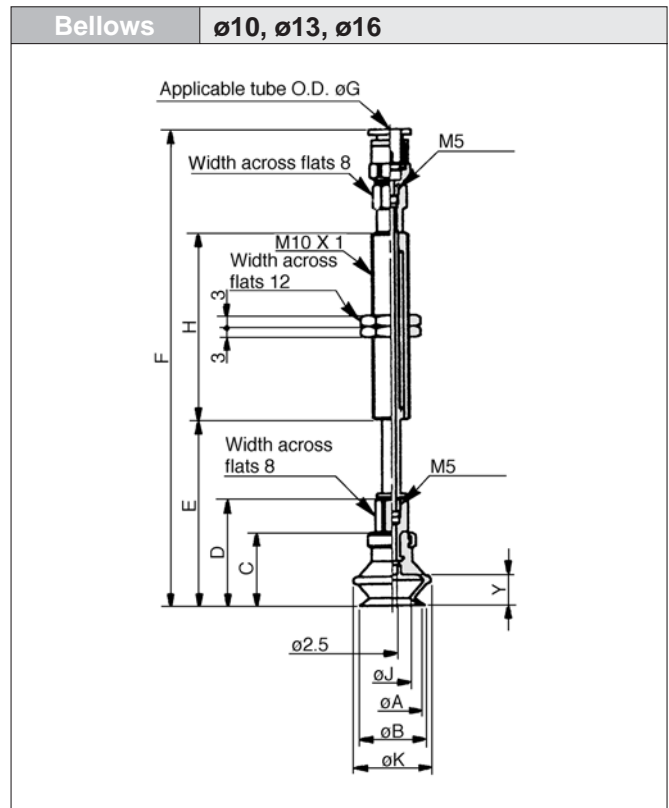
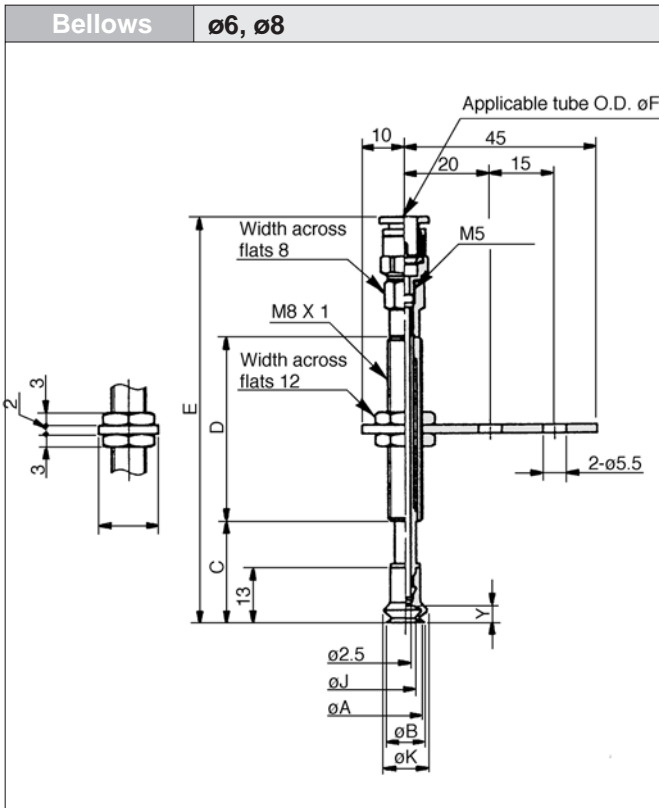

Bellows style

Model	A	B	J	K
ZPT06B□□□□-0□-AB	6	7	3.3	9.1
ZPT08B□□□□-0□-AB	8	9	4.7	10.1

Dimensions by stroke

Model	C	D	E	
			F: ø4	F: ø6
ZPT□□B□□□ 6-0□-A8	19	15	61	62
ZPT□□B□□□10-0□-A8	24	43	94	95
ZPT□□B□□□15-0□-A8	29		99	100
ZPT□□B□□□25-0□-A8	39		109	110

Bellows style

Model	A	B	C	D	J	K	Y
ZPT10B□□□□-0□-A10	10	12	16	25	5.5	13.8	5.5
ZPT13B□□□□-0□-A10	13	15	18.5	27.5	8.7	19	7.5
ZPT16B□□□□-0□-A10	16	18	20	29	9.9	21	8.5

Dimensions by stroke

Model	ø10			ø13			ø16			H
	E	F		E	F		E	F		
		G: ø4	G: ø6		G: ø4	G: ø6		G: ø4	G: ø6	
ZPT□□B□□□10-0□-A10	36.5	86.5	87.5	39	89	90	40.5	90.5	91.5	23
ZPT□□B□□□20-0□-A10	46.5	124.5	125.5	49	127	128	50.5	128.5	129.5	51
ZPT□□B□□□30-0□-A10	56.5	134.5	135.5	59	137	138	60.5	138.5	139.5	
ZPT□□B□□□40-0□-A10	66.5	170.5	171.5	69	173	174	70.5	174.5	185.5	77
ZPT□□B□□□50-0□-A10	76.5	180.5	181.5	79	183	184	80.5	184.5	185.5	

Vertical Vacuum Entry with Buffer Series ZPT

Connection	One-touch Fitting (Buffer)	Pad Style	Bellows
Vacuum Entry	Vertical	Mounting	Buffer Body

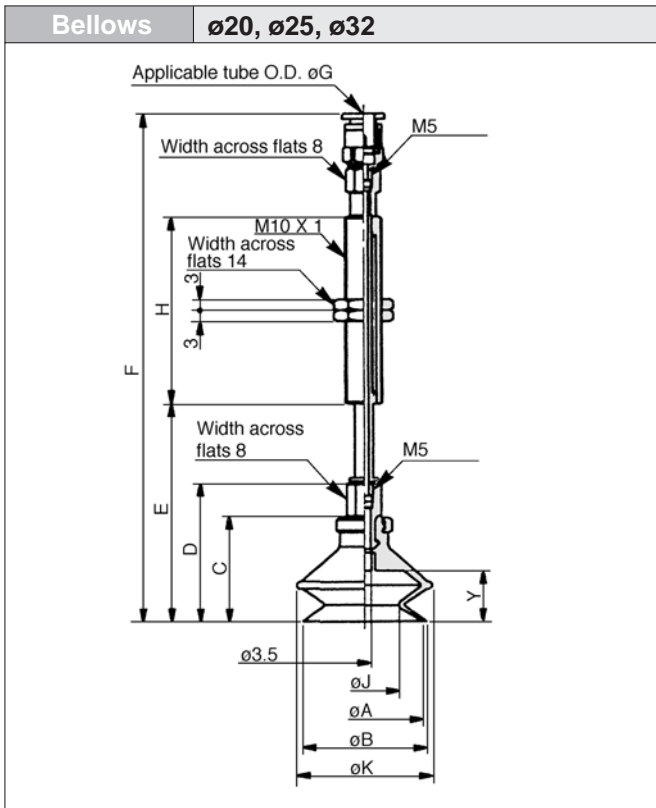

Bellows style

Model	A	B	C	D	J	K	Y
ZPT20B□□□□□-0□-A10	20	22	23.5	32.5	12.4	25	10.5
ZPT25B□□□□□-0□-A10	25	27	24	33	15.6	28	
ZPT32B□□□□□-0□-A10	32	34	29	38	18.9	37	

Dimensions by stroke

Model	ø20		ø25			ø32			H
	E	F	E	F		E	F		
		G: ø4		G: ø6	G: ø4		G: ø6	G: ø4	
ZPT□□B□□□□10-0□-A10	44	94 95	44.5	94.5	95.5	49.5	99.5	100.5	23
ZPT□□B□□□□20-0□-A10	54	132 133	54.5	132.5	133.5	59.5	137.5	138.5	
ZPT□□B□□□□30-0□-A10	64	142 143	64.5	142.5	143.5	69.5	147.5	148.5	
ZPT□□B□□□□40-0□-A10	74	178 179	74.5	178.5	179.5	79.5	183.5	184.5	51
ZPT□□B□□□□50-0□-A10	84	188 189	84.5	188.5	189.5	89.5	193.5	194.5	

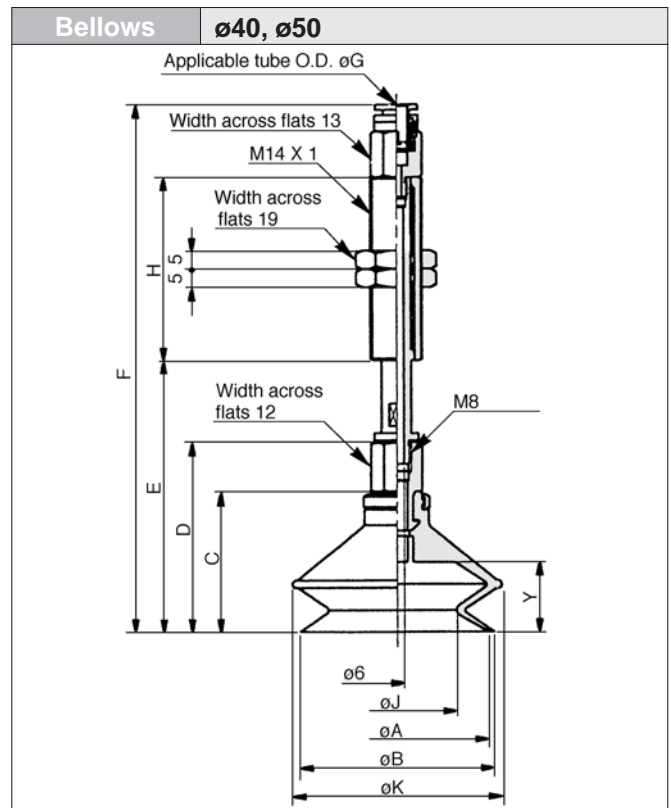

Bellows style

Model	A	B	C	D	J	K	Y
ZPT40B□□□□□-0□-A14	40	43	34	47.5	24.4	48	16
ZPT50B□□□□□-0□-A14	50	53	38	51.5	32.4	57	19

Dimensions by stroke

Model	ø40		ø50		H
	E	F	E	F	
		G: ø6		G: ø8	
ZPT□□B□□□□10-0□-A14	60	145 150.5	64	149 154.5	50
ZPT□□B□□□□20-0□-A14	70	139.9 144.9	74	143.9 148.9	
ZPT□□B□□□□30-0□-A14	80	149.9 154.9	84	153.9 158.9	
ZPT□□B□□□□50-0□-A14	100	194.9 199.9	104	198.9 203.9	

- ZX
- ZR
- ZM
- ZY
- ZH
- ZU
- ZL
- ZF
- ZP**
- ZCU
- CYV
- Vacuum related

Series ZPT

Connection	Barb Fitting (Buffer)	Pad Style	Flat
Vacuum Entry	Vertical	Mounting	Buffer Body

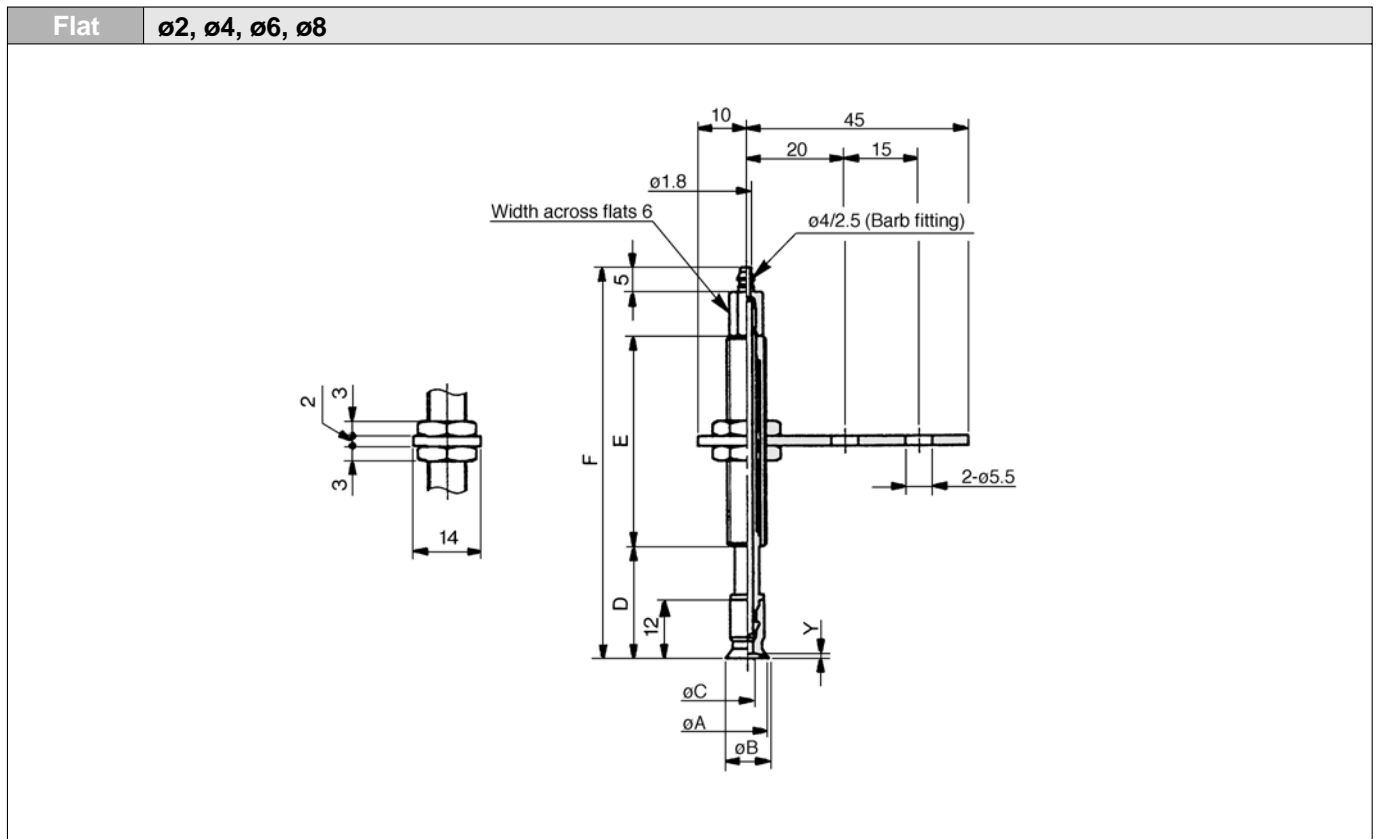

Flat style

Model	A	B	C	Y
ZPT02U□□□□□□□□-□4-A8	2	2.6	1.2	0.8
ZPT04U□□□□□□□□-□4-A8	4	4.8	1.6	
ZPT06U□□□□□□□□-□4-A8	6	7	2.5	
ZPT08U□□□□□□□□-□4-A8	8	9		1

Dimensions by stroke

Model	D	E	F
ZPT□□U□□□□6-□4-A8	18	15	47
ZPT□□U□□□□10-□4-A8	23		80
ZPT□□U□□□□15-□4-A8	28	43	85
ZPT□□U□□□□25-□4-A8	38		95

Vertical Vacuum Entry with Buffer Series ZPT

Connection	Barb Fitting (Buffer)	Pad Style	Flat/Flat with Ribs/Deep
Vacuum Entry	Vertical	Mounting	Buffer Body

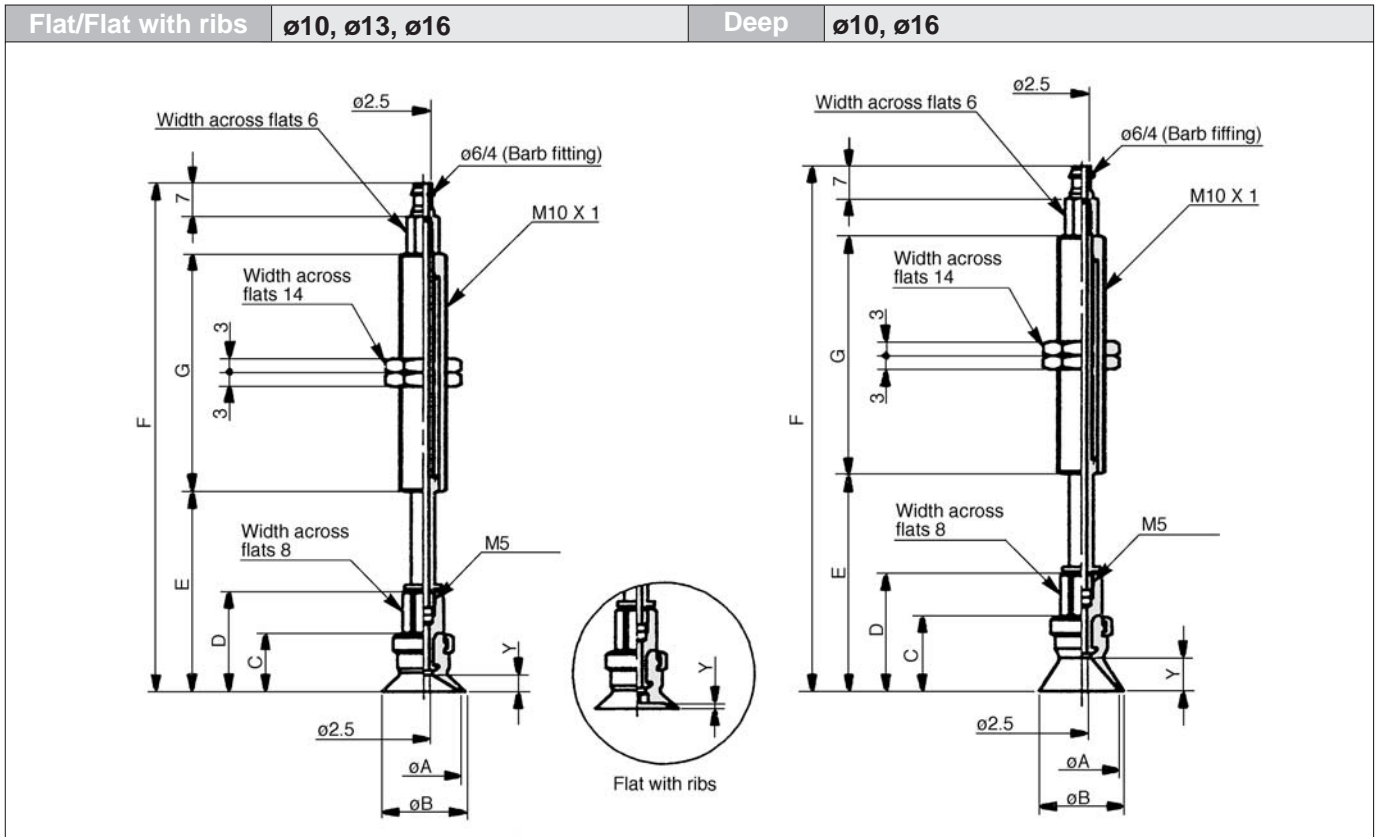

- ZX
- ZR
- ZM
- ZY
- ZH
- ZU
- ZL
- ZF
- ZP**
- ZCU
- CYV
- Vacuum related

Flat style/Flat with ribs

Model	A	B	C	D	Y	
					Flat	Flat with ribs
ZPT10 _C □□□□□□-□6-A10	10	12	12	21	3	1.7
ZPT13 _C □□□□□□-□6-A10	13	15				1.8
ZPT16 _C □□□□□□-□6-A10	16	18	12.5	21.5	3.5	1.2

Dimensions by stroke

Model	ø10, ø13		ø16		G
	E	F	E	F	
ZPT□□ _C □□□□□□10-□6-A10	32.5	70.5	33	71	23
ZPT□□ _C □□□□□□20-□6-A10	42.5	108.5	43	109	
ZPT□□ _C □□□□□□30-□6-A10	52.5	118.5	53	119	51
ZPT□□ _C □□□□□□40-□6-A10	62.5	154.5	63	155	
ZPT□□ _C □□□□□□50-□6-A10	72.5	164.5	73	165	77

Deep style

Model	A	B	C	D	Y
ZPT10D _C □□□□□□-□6-A10	10	12	15	24	6
ZPT16D _C □□□□□□-□6-A10	16	18	16	25	7

Dimensions by stroke

Model	ø10		ø16		G
	E	F	E	F	
ZPT□□D□□□□□10-□6-A10	35.5	73.5	36.5	74.5	23
ZPT□□D□□□□□20-□6-A10	45.5	111.5	46.5	112.5	
ZPT□□D□□□□□30-□6-A10	55.5	121.5	56.5	122.5	51
ZPT□□D□□□□□40-□6-A10	65.5	157.7	66.5	158.5	
ZPT□□D□□□□□50-□6-A10	75.5	167.5	76.5	168.5	77

Series ZPT

Connection	Barb Fitting (Buffer)	Pad Style	Flat/Flat with Ribs/Deep
Vacuum Entry	Vertical	Mounting	Buffer Body

Flat/Flat with ribs	ø20, ø25, ø32	Deep	ø25
----------------------------	----------------------	-------------	------------

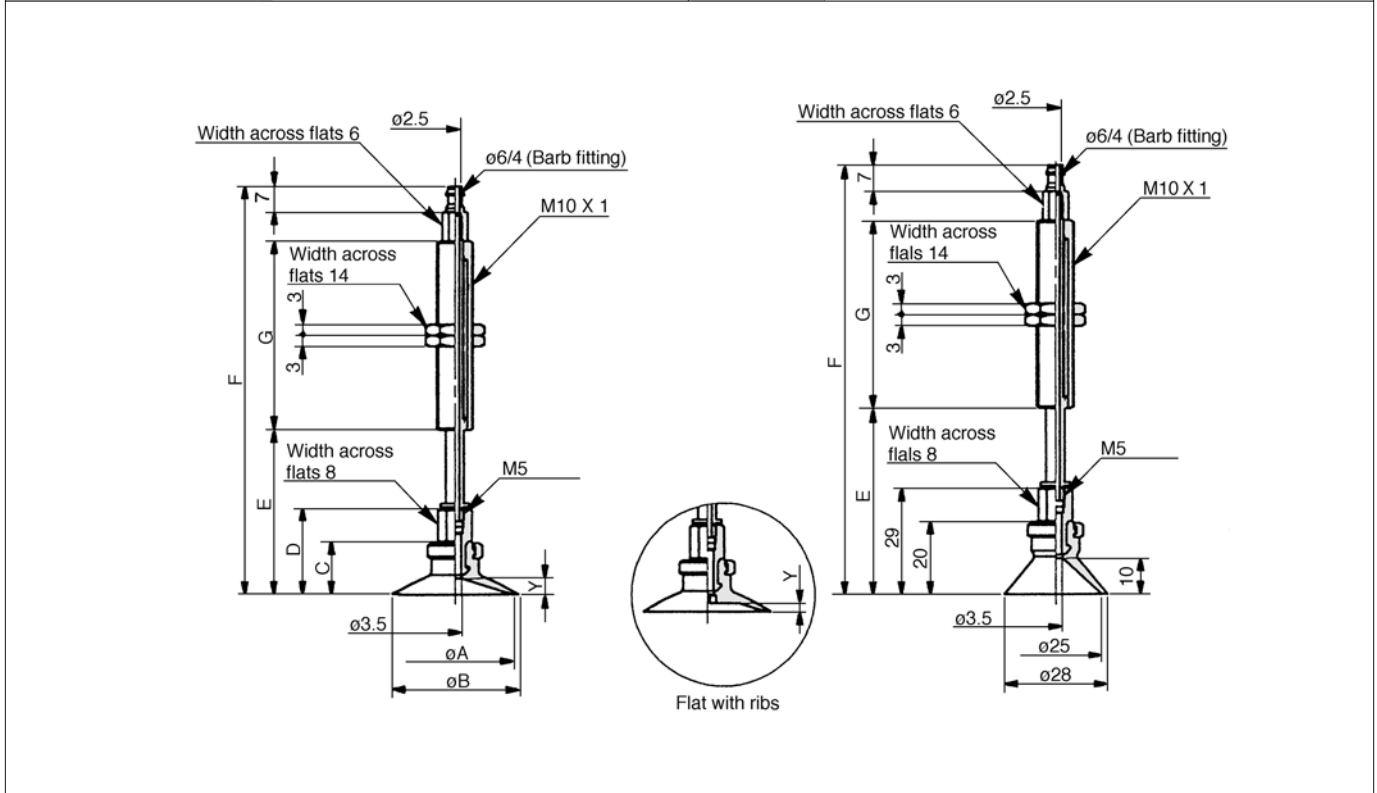

Flat style/Flat with ribs

Model	A	B	C	D	Y	
					Flat	Flat with ribs
ZPT20 _C □□□□□□□□□□6-A10	20	23	14	23	4	1.7
ZPT25 _C □□□□□□□□□□6-A10	25	28				1.8
ZPT32 _C □□□□□□□□□□6-A10	32	35	14.5	23.5	4.5	2.3

Deep style

Model	E	F	G
ZPT25D□□□□□□□□□□6-A10	40.5	78.5	23
ZPT25D□□□□□□□□□□20-□6-A10	50.5	116.5	51
ZPT25D□□□□□□□□□□30-□6-A10	60.5	126.5	
ZPT25D□□□□□□□□□□40-□6-A10	70.5	162.5	77
ZPT25D□□□□□□□□□□50-□6-A10	80.5	172.5	

Dimensions by stroke

Model	ø20, ø25		ø32		G
	E	F	E	F	
ZPT□□ _C □□□□□□□□□□10-□6-A10	34.5	72.5	35	73	23
ZPT□□ _C □□□□□□□□□□20-□6-A10	44.5	110.5	45	111	51
ZPT□□ _C □□□□□□□□□□30-□6-A10	54.5	120.5	55	121	
ZPT□□ _C □□□□□□□□□□40-□6-A10	64.5	156.5	65	157	77
ZPT□□ _C □□□□□□□□□□50-□6-A10	74.5	166.5	75	167	

Vertical Vacuum Entry with Buffer Series ZPT

Connection	Barb Fitting (Buffer)	Pad Style	Flat/Flat with Ribs/Deep
Vacuum Entry	Vertical	Mounting	Buffer Body

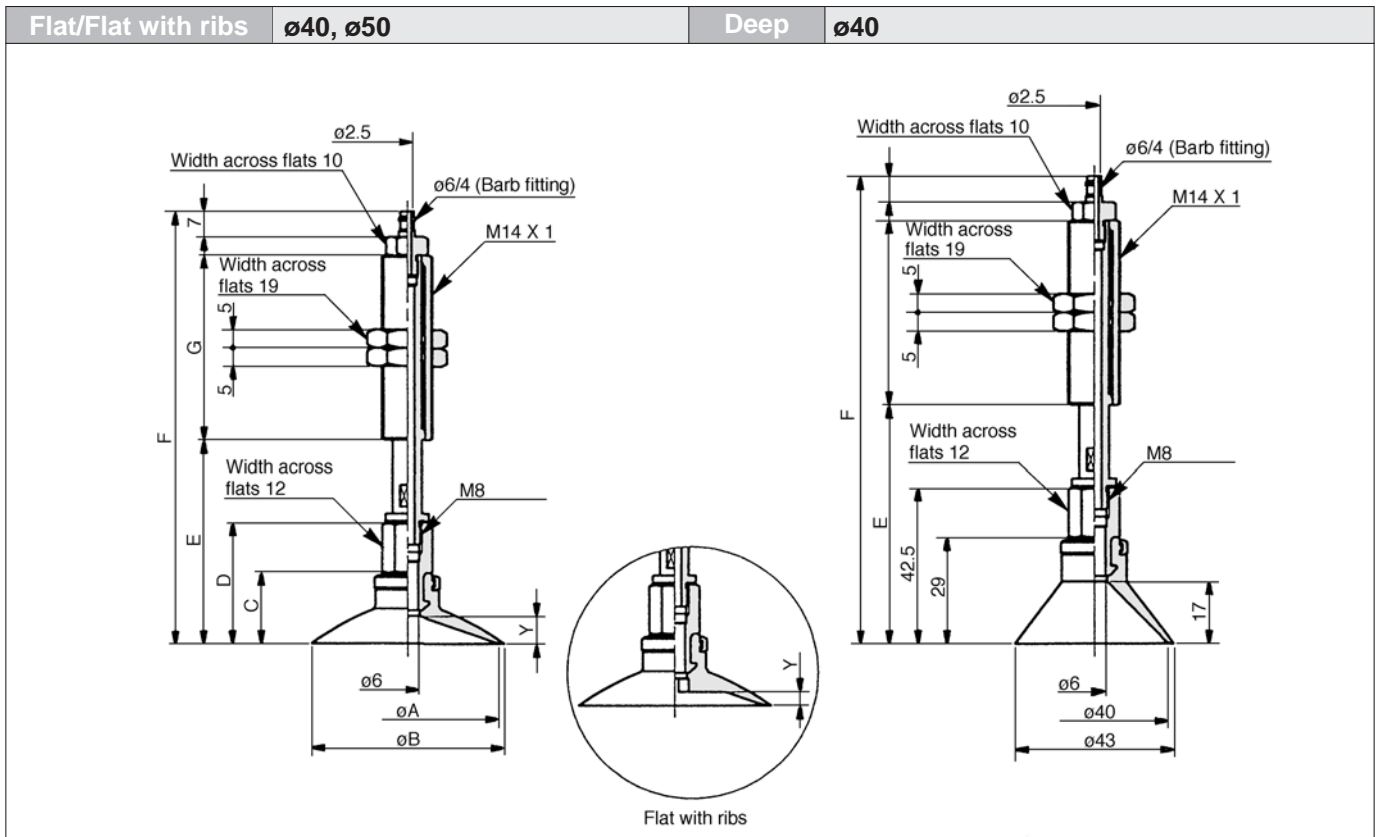

- ZX
- ZR
- ZM
- ZY
- ZH
- ZU
- ZL
- ZF
- ZP**
- ZCU
- CYV
- Vacuum related

Flat style/Flat with ribs

Model	A	B	C	D	Y	
					Flat	Flat with ribs
ZPT40 $\frac{U}{C}$ □□□□□□□□□□6-A14	40	43	18.5	32	6.5	3.3
ZPT50 $\frac{U}{C}$ □□□□□□□□□□6-A14	50	53	19.5	33	7.5	3.8

Dimensions by stroke

Model	ø40		ø50		G
	E	F	E	F	
ZPT□□ $\frac{U}{C}$ □□□□10-□6-A14	44.5	113.5	45.5	114.5	50
ZPT□□ $\frac{U}{C}$ □□□□20-□6-A14	54.5	116.5	55.5	117.5	
ZPT□□ $\frac{U}{C}$ □□□□30-□6-A14	64.5	126.5	65.5	127.5	
ZPT□□ $\frac{U}{C}$ □□□□50-□6-A14	84.5	171.5	85.5	172.5	

Deep style

Model	E	F	G
ZPT40D□□□□10-□6-A14	55	124	50
ZPT40D□□□□20-□6-A14	65	127	
ZPT40D□□□□30-□6-A14	75	137	75
ZPT40D□□□□50-□6-A14	95	182	

Series ZPT

Connection	Barb Fitting (Buffer)	Pad Style	Bellows
Vacuum Entry	Vertical	Mounting	Buffer Body

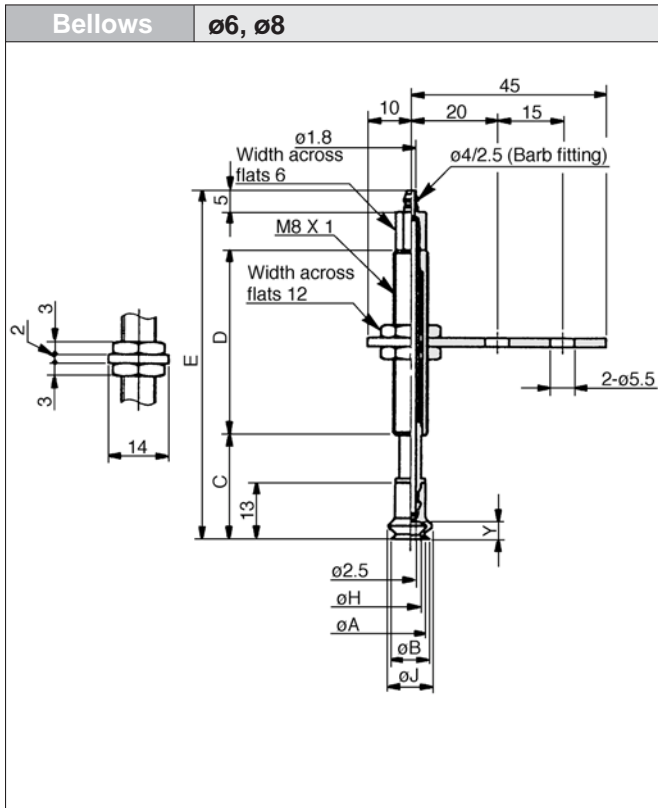

Bellows style

Model	A	B	H	J
ZPT06B□□□□-□4-A8	6	7	3.3	9.1
ZPT08B□□□□-□4-A8	8	9	4.7	10.1

Dimensions by stroke

Model	C	D	E
ZPT□□B□□□ 6-□4-A8	19	15	48
ZPT□□B□□□10-□4-A8	24		81
ZPT□□B□□□15-□4-A8	29	43	86
ZPT□□B□□□25-□4-A8	39		96

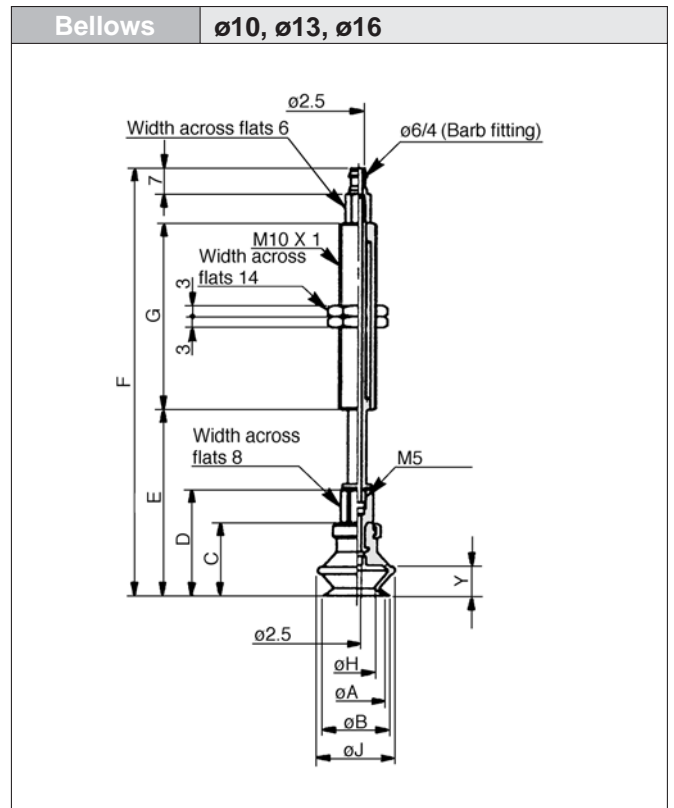

Bellows style

Model	A	B	C	D	H	J	Y
ZPT10B□□□□-□6-A10	10	12	16	25	5.5	13.8	5.5
ZPT13B□□□□-□6-A10	13	15	18.5	27.5	8.7	19	7.5
ZPT16B□□□□-□6-A10	16	18	20	29	9.9	21	8.5

Dimensions by stroke

Model	$\phi 10$		$\phi 13$		$\phi 16$		G
	E	F	E	F	E	F	
ZPT□□B□□□10-□6-A10	36.5	74.5	39	77	40.5	78.5	23
ZPT□□B□□□20-□6-A10	46.5	112.5	49	115	50.5	116.5	51
ZPT□□B□□□30-□6-A10	56.5	122.5	59	125	60.5	126.5	
ZPT□□B□□□40-□6-A10	66.5	158.5	69	161	70.5	162.5	77
ZPT□□B□□□50-□6-A10	76.5	168.5	79	171	80.5	172.5	

Vertical Vacuum Entry with Buffer Series ZPT

Connection	Barb Fitting (Buffer)	Pad Style	Bellows
Vacuum Entry	Vertical	Mounting	Buffer Body

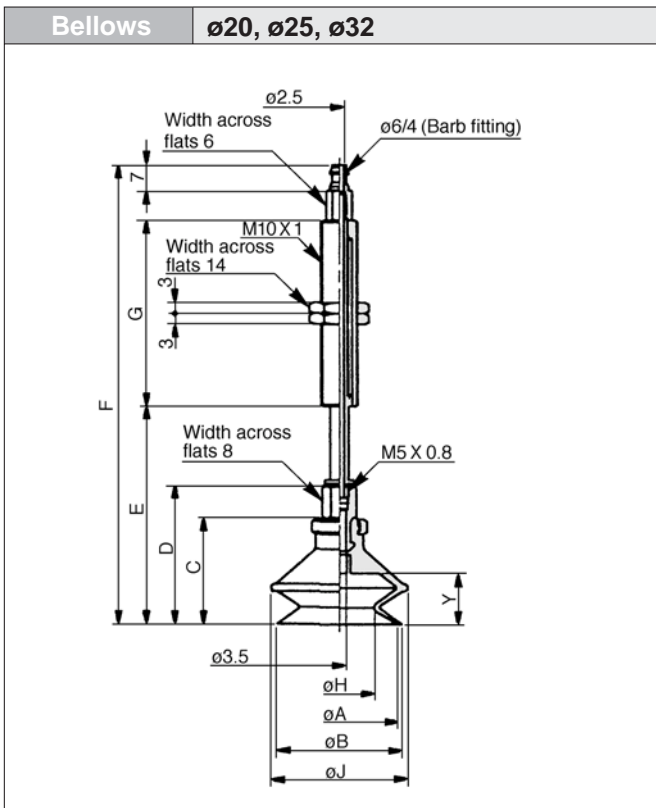

Bellows style

Model	A	B	C	D	H	J	Y
ZPT20B□□□□□-□6A10	20	22	23.5	32.5	12.4	25	10.5
ZPT25B□□□□□-□6A10	25	27	24	33	15.6	28	
ZPT32B□□□□□-□6A10	32	34	29	38	18.9	37	

Dimensions by stroke

Model	ø20		ø25		ø32		G
	E	F	E	F	E	F	
ZPT□□B□□□□10-□6A10	44	82	44.5	82.5	49.5	87.5	23
ZPT□□B□□□□20-□6A10	54	120	54.5	120.5	59.5	125.5	
ZPT□□B□□□□30-□6A10	64	130	64.5	130.5	69.5	135.5	51
ZPT□□B□□□□40-□6A10	74	166	74.5	166.5	79.5	171.5	
ZPT□□B□□□□50-□6A10	84	176	84.5	176.5	89.5	181.5	77

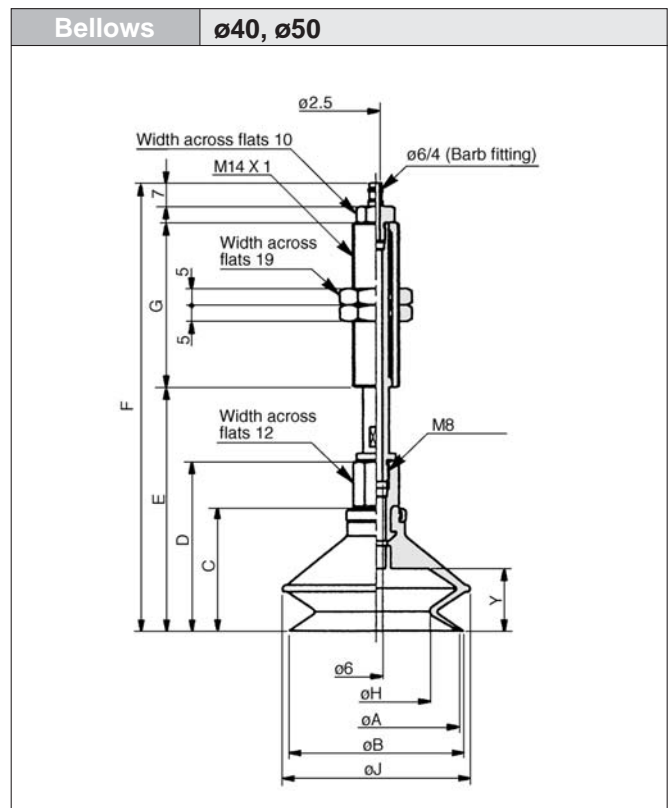

Bellows style

Model	A	B	C	D	H	J	Y
ZPT40B□□□□□-□6A14	40	43	34	47.5	24.4	48	16
ZPT50B□□□□□-□6A14	50	53	38	51.5	32.4	57	19

Dimensions by stroke

Model	ø40		ø50		G
	E	F	E	F	
ZPT□□B□□□□10-□6A14	60	129	64	133	50
ZPT□□B□□□□20-□6A14	70	132	74	136	
ZPT□□B□□□□30-□6A14	80	142	84	146	
ZPT□□B□□□□50-□6A14	100	187	104	191	

ZX

ZR

ZM

ZY

ZH

ZU

ZL

ZF

ZP

ZCU

CYV

Vacuum related



ZPR Lateral Vacuum Entry without Buffer With One-touch Fitting



Specifications

Vacuum entry	Direction		Lateral	
	Connection		One-touch fitting	
Tube dia.	ø2 to ø8		ø4, ø6 Tube	
	ø10 to ø16		ø4, ø6 Tube	
	ø20 to ø32		ø4, ø6, ø8 Tube	
	ø40 to ø50		ø6, ø8 Tube	
Mounting	Connection		Male thread	Female thread
	Thread dia.	ø2 to ø8	M5, M6	M4, M5
		ø10 to ø16	M5, M6	M5, M6
		ø20 to ø32	M6, M8 X 1	M5, M6, M8
		ø40 to ø50	M6, M8 X 1	M6, M8

Pad Style

Pad style	Flat	Flat with ribs	Deep	Bellows
Pad dia. ø(mm)	2, 4, 6, 8, 10, 13, 16, 20, 25, 32, 40, 50	10, 13, 16, 20, 25, 32, 40, 50	10, 16, 25, 40	6, 8, 10, 13, 16, 20, 25, 32, 40, 50
Material (colour)	NBR (Black), Silicon rubber (White), Urethane rubber (Brown), Fluorine rubber (Black with green mark), Conductive NBR (Black with one white mark), Conductive silicon rubber (Black with two white marks)			
Durometer	NBR (50°), Silicon rubber (40°), Urethane rubber/Fluorine rubber (60°), Conductive NBR (50°), Conductive silicon rubber (50°)			

Weight Table/Male Thread (Female Thread)

Model	Flat		Flat with ribs			Deep			Bellows					
	M4	M5	M6	M8	M5	M6	M8	M5	M6	M8	M4	M5	M6	M8
ZPR02 to ZPR08	— (19)	26 (20)	27 (—)	—	—	—	—	—	—	—	19 (Except for ø2, ø4)	26(20) (Except for ø2, ø4)	27(—) (Except for ø2, ø4)	—
ZPR10	—	29 (23)	31 (21)	—	29 (23)	31 (22)	—	29 (23)	30 (22)	—	—	29 (23)	31 (22)	—
ZPR13	—	29 (23)	31 (21)	—	29 (23)	31 (22)	—	31 (23)	31 (22)	—	—	29 (23)	31 (22)	—
ZPR16	—	29 (23)	31 (21)	—	29 (23)	31 (22)	—	31 (23)	31 (22)	—	—	29 (23)	31 (22)	—
ZPR20	—	—	57 (50)	61 (48)	—	57 (50)	61 (48)	—	—	—	—	—	57 (50)	61 (48)
ZPR25	—	— (51)	57 (50)	61 (48)	—	57 (50)	61 (48)	—	65 (50)	68 (48)	—	— (51)	57 (50)	61 (48)
ZPR32	—	—	57 (50)	61 (48)	—	57 (50)	61 (48)	—	—	—	—	—	57 (50)	61 (48)
ZPR40	—	—	64 (56)	67 (54)	—	64 (56)	67 (54)	—	65 (57)	68 (55)	—	—	64 (56)	67 (54)
ZPR50	—	—	66 (58)	69 (56)	—	67 (59)	70 (57)	—	—	—	—	—	66 (58)	69 (56)

*(): Figures for female thread connections.

 P.3.9-64 to 3.9-69

Lateral Vacuum Entry without Buffer Series ZPR

Model

Model	Pad dia. ϕ (mm)	Pad style				Vacuum entry (One-touch fitting)	Mounting thread	
		Flat (U)	Flat with ribs (C)	Deep (D)	Bellows (B)		Male thread	Female thread
ZPR02	2	●	—	—	—	● $\phi 4/\phi 6$ tube	● M5 M6	● M4 M5
ZPR04	4	●	—	—	—			
ZPR06	6	●	—	—	—			
ZPR08	8	●	—	—	●			
ZPR10	10	●	●	●	●	● $\phi 4/\phi 6$ tube	● M5 M6	● M5 M6
ZPR13	13	●	●	—	●			
ZPR16	16	●	●	●	●			
ZPR20	20	●	●	—	●			
ZPR25	25	●	●	●	●	● $\phi 4/\phi 6/\phi 8$ tube	● M6 M8 X 1	● M5 M6 M8
ZPR32	32	●	●	—	●			
ZPR40	40	●	●	●	●			
ZPR50	50	●	●	—	●			

How to Order

Series ZPR
without buffer

ZPR 02 U N 04 A5

Pad dia. (mm)

02	$\phi 2$
04	$\phi 4$
06	$\phi 6$
08	$\phi 8$
10	$\phi 10$
13	$\phi 13$
16	$\phi 16$
20	$\phi 20$
25	$\phi 25$
32	$\phi 32$
40	$\phi 40$
50	$\phi 50$

Pad style



(Refer to Table ① for applications.)

U	Flat
C	Flat with ribs
D	Deep
B	Bellows

Mounting thread



(Refer to Table ② for applications.)

Vacuum entry



(Refer to Table ② for applications.)

Table ② Vacuum Entry/Mounting Thread Dia.

Connection	Symbol	Thread dia. /Port size	$\phi 2$ to $\phi 8$	$\phi 10$ to $\phi 16$	$\phi 20$ to $\phi 32$	$\phi 40$ to $\phi 50$
Vacuum entry One-touch fitting	04	$\phi 4$ tube	●	●	●	—
	06	$\phi 6$ tube	●	●	●	●
	08	$\phi 8$ tube	—	—	●	●
Mounting Male thread	A5	M5	●	●	—	—
	A6	M6	●	●	●	●
	A8	M8 X 1	—	—	●	●
	B4	M4	●	—	—	—
	B5	M5	●	●	●	—
	B6	M6	—	●	●	●
Female thread	B8	M8	—	—	●	●

Material

N	NBR
S	Silicon rubber
U	Urethane rubber
F	Fluorine rubber
GN*	Conductive NBR ($\phi 2$ to $\phi 16$)
GS*	Conductive silicon rubber ($\phi 2$ to $\phi 16$)

* $\phi 20$ and larger are manufactured upon receipt of order.

Table ① Pad Dia. /Pad Style

Style \ Dia. (mm)	2	4	6	8	10	13	16	20	25	32	40	50
Flat	●	●	●	●	●	●	●	●	●	●	●	●
Flat with ribs	—	—	—	—	●	●	●	●	●	●	●	●
Deep	—	—	—	—	●	—	●	—	●	—	●	—
Bellows	—	—	●	●	●	●	●	●	●	●	●	●

ZX

ZR

ZM

ZY

ZH

ZU

ZL

ZF

ZP

ZCU

CYV

Vacuum related

Series ZPR

Connection	One-touch Fitting	Pad Style	Flat/Flat with Ribs/Deep
Vacuum Entry	Lateral	Mounting	Male Thread

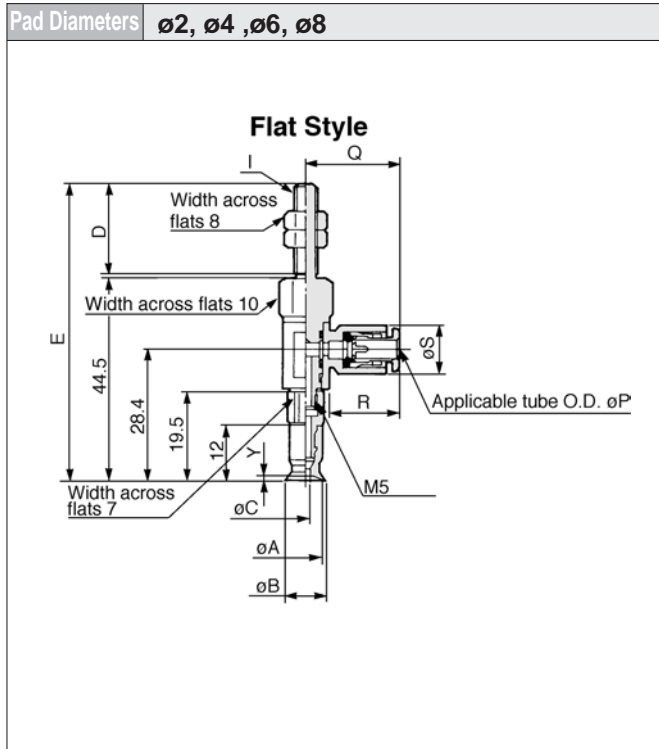

Flat style

Model	$\varnothing A$	$\varnothing B$	$\varnothing C$	I: M5		I: M6		Y
				D	E	D	E	
ZPR02U	2	2.6	1.2	20	65.5	25	70.5	0.8
ZPR04U	4	4.8	1.6					
ZPR06U	6	7	2.5					
ZPR08U	8	9	2.5					

Applicable tube

Applicable tube O.D.	$\varnothing P$	Q	R	$\varnothing S$
$\varnothing 4$	4	20.6	15.6	10.4
$\varnothing 6$	6	21.6	16.6	12.8

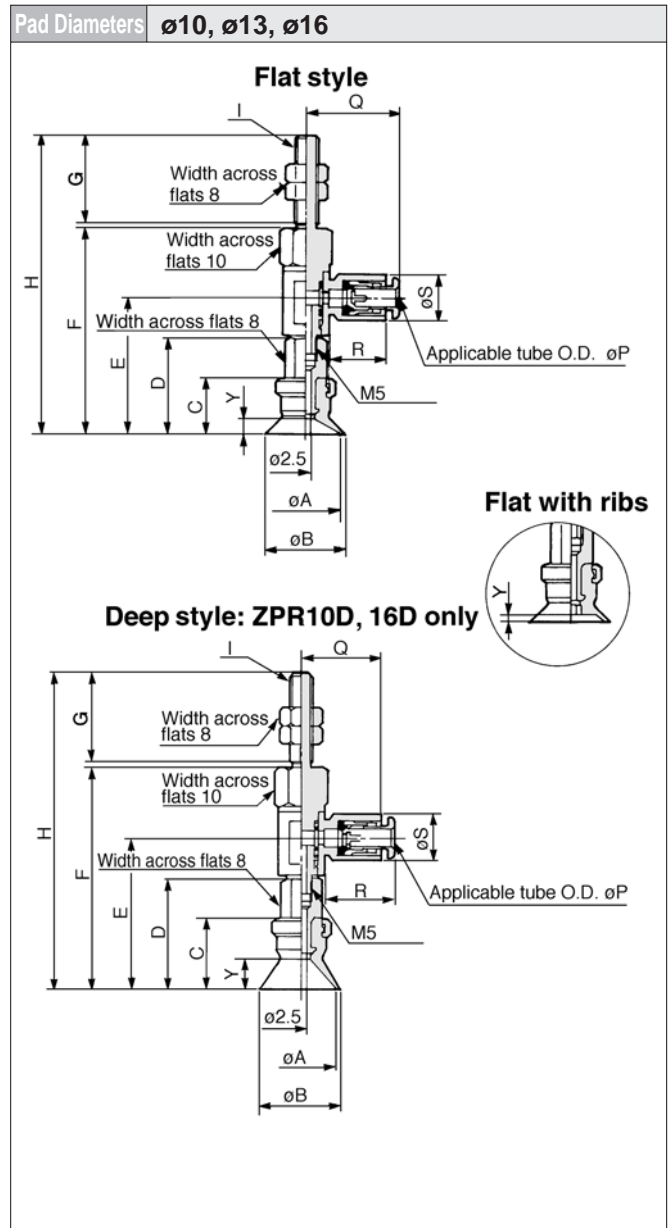

Flat style/Flat with ribs

Model	$\varnothing A$	$\varnothing B$	C	D	E	F	I: M5		I: M6		Y	
							G	H	G	H	Flat	Flat w/ ribs
ZPR10 _C	10	12	12	21	29.9	46	20	67	25	72	3	1.7
ZPR13 _C	13	15	12	21	29.9	46						1.8
ZPR16 _C	16	18	12.5	21.5	30.4	46.5						67.5

Deep style

Model	$\varnothing A$	$\varnothing B$	C	D	E	F	I: M5		I: M6		Y
							G	H	G	H	
ZPR10D	10	12	15	24	32.9	49	20	70	25	75	6
ZPR16D	16	18	16	25	33.9	50					

Applicable tube

Applicable tube O.D.	$\varnothing P$	Q	R	$\varnothing S$
$\varnothing 4$	4	20.6	15.6	10.4
$\varnothing 6$	6	21.6	16.6	12.8

Lateral Vacuum Entry without Buffer Series ZPR

Connection	One-touch Fitting	Pad Style	Flat/Flat with Ribs/Deep
Vacuum Entry	Lateral	Mounting	Male Thread

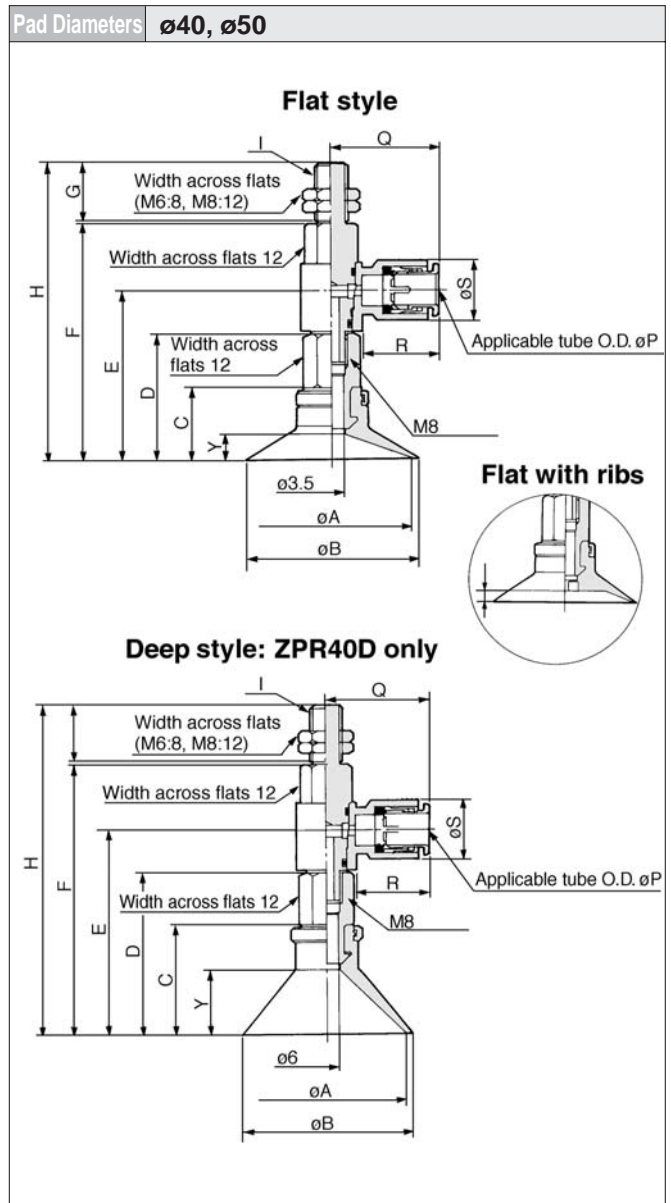
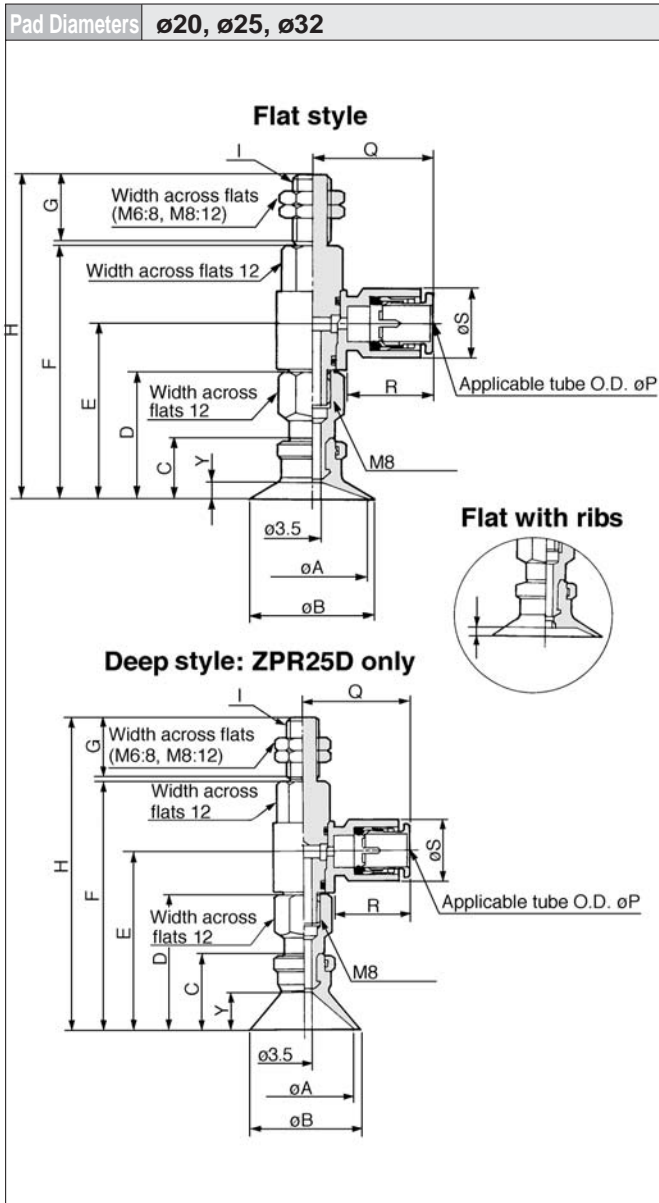

- ZX
- ZR
- ZM
- ZY
- ZH
- ZU
- ZL
- ZF
- ZP**
- ZCU
- CYV
- Vacuum related

Flat style/Flat with ribs

Model	ϕA	ϕB	C	D	E	F	I: M6		I: M8 X 1		Y	
							G	H	G	H	Flat	Flat w/ ribs
ZPR20 ^U _C	20	23	14	29	39.8	57.6	25	83.5	15	73.5	4	1.7
ZPR25 ^U _C	25	28										1.8
ZPR32 ^U _C	32	35	14.5	29.5	40.3	58.1						84

Deep style

Model	ϕA	ϕB	C	D	E	F	I: M6		I: M8 X 1		Y
							G	H	G	H	
ZPR25D	25	28	20	35	48.5	63.6	25	89.5	15	79.5	10

Applicable tube

Applicable tube O.D.	ϕP	Q	R	ϕS
$\phi 4$	4	23.3	15.8	10.4
$\phi 6$	6	24.3	16.8	12.8
$\phi 8$	8	26.2	18.7	15.2

Flat style/Flat with ribs

Model	ϕA	ϕB	C	D	E	F	I: M6		I: M8 X 1		Y					
							G	H	G	H	Flat	Flat w/ ribs				
ZPR40 ^U _C	40	43	18.5	32	42.8	60.6	25	86.5	15	76.5	6.5	3.3				
ZPR50 ^U _C	50	53	19.5	33	43.8	61.6							87.5	77.5	7.5	3.8

Deep style

Model	ϕA	ϕB	C	D	E	F	I: M6		I: M8 X 1		Y
							G	H	G	H	
ZPR40D	40	43	29	42.5	53.3	71.1	25	97	15	87	17

Applicable tube

Applicable tube O.D.	ϕP	Q	R	ϕS
$\phi 6$	6	24.3	16.8	12.8
$\phi 8$	8	26.2	18.7	15.2

Series ZPR

Connection	One-touch Fitting	Pad Style	Bellows
Vacuum Entry	Lateral	Mounting	Male Thread

Pad Diameters **ø6, ø8**

Bellows style

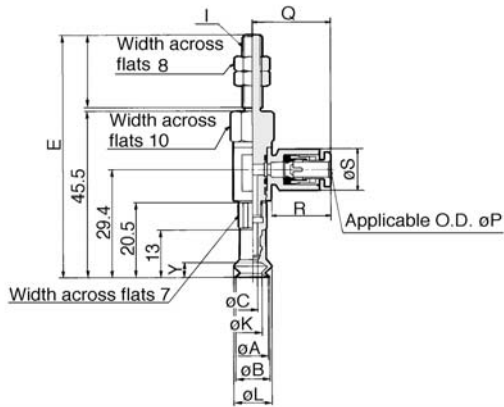

Model	øA	øB	øC	I: M5		I: M6		øK	øL	Y
				D	E	D	D			
ZPR06B	6	7	2.5	20	66.5	25	71.5	3.3	9.1	4
ZPR08B	8	9								

Applicable tube

Applicable tube O.D.	øP	Q	R	øS
ø4	4	20.6	15.6	10.4
ø6	6	21.6	16.6	12.8

Pad Diameters **ø20, ø25, ø32**

Bellows style

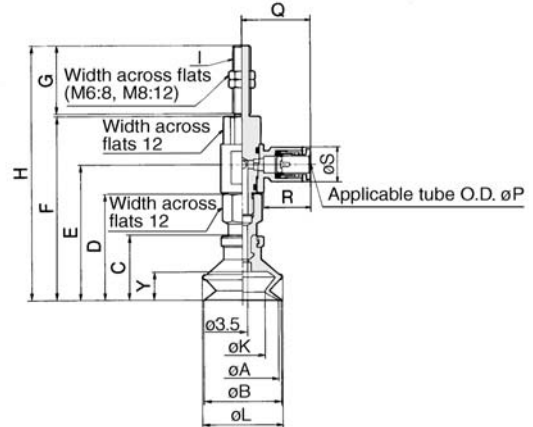

Model	øA	øB	C	D	E	F	I: M6		I: M8 X 1		øK	øL	Y
							G	H	G	H			
ZPR20B	20	22	23.5	38.5	49.3	67.1	25	93	15	83	12.4	25	10.5
ZPR25B	25	27	24	39	49.8	67.6							
ZPR32B	32	34	29	44	54.8	72.6	98.5	88.5	18.9	37	14		

Applicable tube

Applicable tube O.D.	øP	Q	R	øS
ø4	4	23.3	15.8	10.4
ø6	6	24.3	16.8	12.8
ø8	8	26.2	18.7	15.2

Pad Diameters **ø10, ø13, ø16**

Bellows style

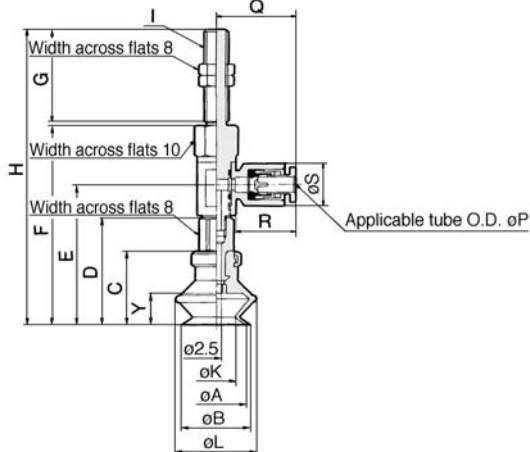

Model	øA	øB	C	D	E	F	I: M5		I: M6		øK	øL	Y					
							G	H	G	H								
ZPR10B	10	12	16	25	33.9	50	20	71	25	76	5.5	13.8	5.5					
ZPR13B	13	15	18.5	27.5	36.4	52.5								73.5	78.5	8.7	19	7.5
ZPR16B	16	18	20	29	37.9	54								75	80	9.9	21	8.5

Applicable tube

Applicable tube O.D.	øP	Q	R	øS
ø4	4	20.6	15.6	10.4
ø6	6	21.6	16.6	12.8

Pad Diameters **ø40, ø50**

Bellows style

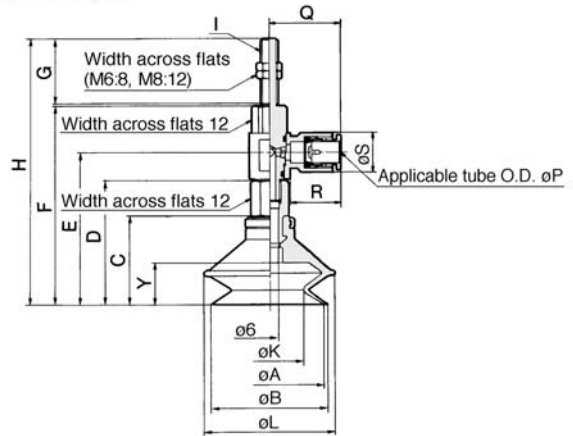

Model	øA	øB	C	D	E	F	I: M6		I: M8 X 1		øK	øL	Y
							G	H	G	H			
ZPR40B	40	43	34	47.5	58.3	76.1	25	102	15	92	24.4	48	16
ZPR50B	50	53	38	51.5	62.3	80.1							

Applicable tube

Applicable tube O.D.	øP	Q	R	øS
ø6	6	24.3	16.8	12.8
ø8	8	26.2	18.7	15.2

Lateral Vacuum Entry without Buffer Series ZPR

Connection	One-touch Fitting	Pad Style	Flat/Flat with Ribs/Deep
Vacuum Entry	Lateral	Mounting	Female Thread

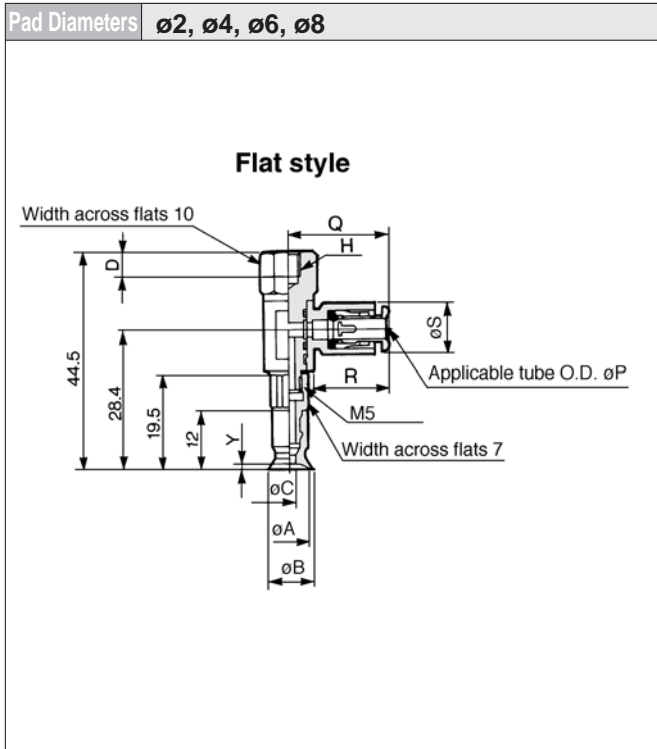

Flat style

Model	$\varnothing A$	$\varnothing B$	$\varnothing C$	H:		Y
				M4	M5	
ZPR02U	2	2.6	1.2	4	5	0.8
ZPR04U	4	4.8	1.6			
ZPR06U	6	7	2.5			
ZPR08U	8	9	2.5			

Applicable tube

Applicable tube O.D.	$\varnothing P$	Q	R	$\varnothing S$
$\varnothing 4$	4	20.6	15.6	10.4
$\varnothing 6$	6	21.6	16.6	12.8

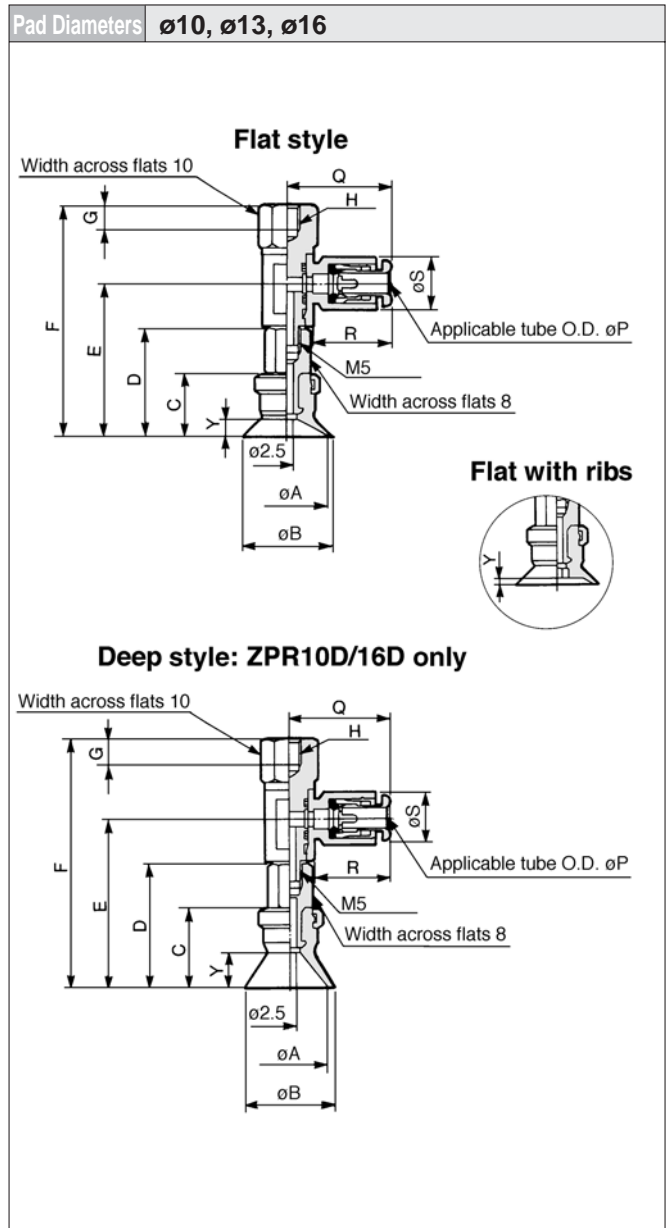

Flat style/Flat with ribs

Model	$\varnothing A$	$\varnothing B$	C	D	E	F	H:		Y	
							M5	M6	Flat	Flat with ribs
ZPR10 _U _C	10	12	12	21	29.9	46	5	6	3	1.7
ZPR13 _U _C	13	15								1.8
ZPR16 _U _C	16	18								3.5

Deep style

Model	$\varnothing A$	$\varnothing B$	C	D	E	F	H:		Y
							M5	M6	
ZPR10D	10	12	15	24	32.9	49	5	6	6
ZPR16D	16	18	16	25	33.9	50			7

Applicable tube

Applicable tube O.D.	$\varnothing P$	Q	R	$\varnothing S$
$\varnothing 4$	4	20.6	15.6	10.4
$\varnothing 6$	6	21.6	16.6	12.8

- ZX
- ZR
- ZM
- ZY
- ZH
- ZU
- ZL
- ZF
- ZP
- ZCU
- CYV
- Vacuum related

Series ZPR

Connection	One-touch Fitting	Pad Style	Flat/Flat with Ribs/Deep
Vacuum Entry	Lateral	Mounting	Female Thread

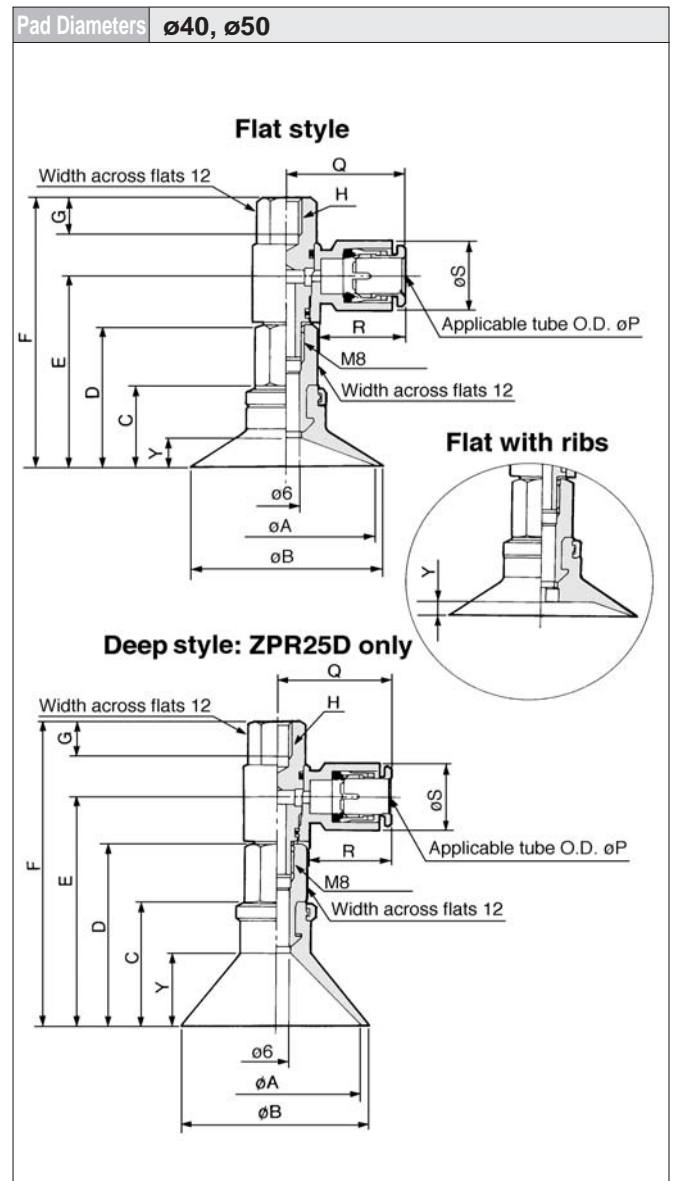
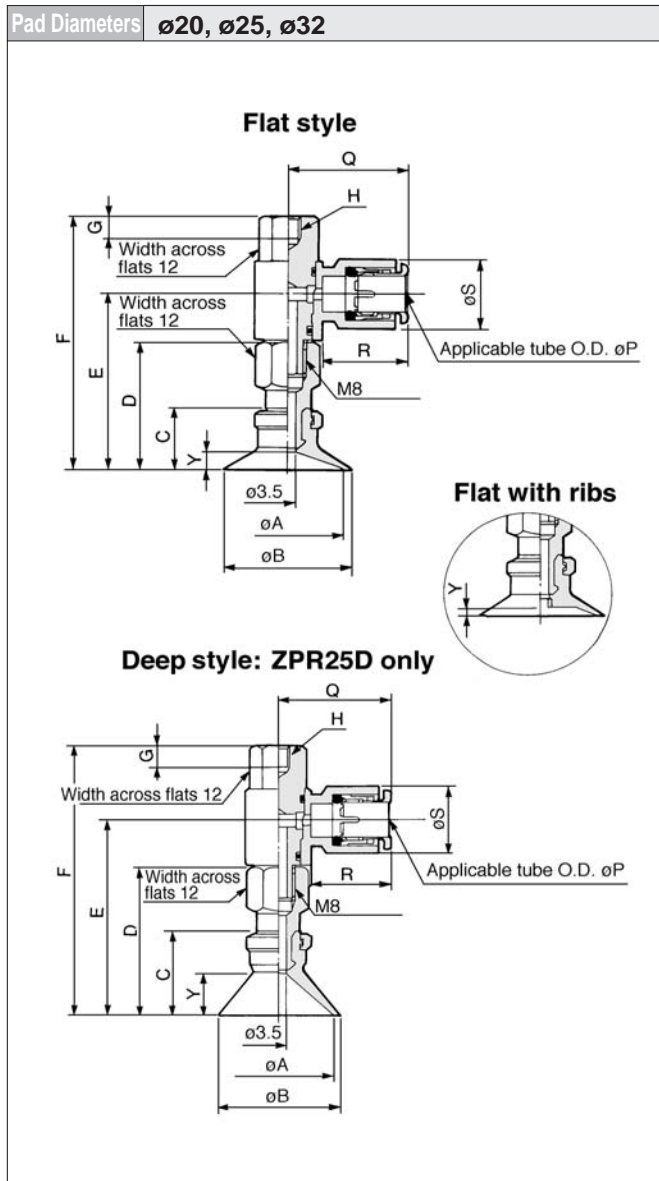

Flat style/Flat with ribs

Model	ϕA	ϕB	C	D	E	F	H: M5			Y	
							G	G	G	Flat	Flat with ribs
ZPR20 _{UC}	20	23	14	29	39.8	57.6	5	6	8	4	1.7
ZPR25 _{UC}	25	28	14	29	39.8	57.6	5	6	8	4	1.8
ZPR32 _{UC}	32	35	14.5	29.5	40.3	58.1	5	6	8	4.5	2.3

Deep style

Model	ϕA	ϕB	C	D	E	F	H: M5			Y
							G	G	G	
ZPR25D	25	28	20	35	45.8	63.6	5	6	8	10

Applicable tube

Applicable tube O.D.	ϕP	Q	R	ϕS
$\phi 4$	4	23.3	15.8	10.4
$\phi 6$	6	24.3	16.8	12.8
$\phi 8$	8	26.2	18.7	15.2

Flat style/Flat with ribs

Model	ϕA	ϕB	C	D	E	F	H: M6		H: M8		Y	
							G	G	G	G	Flat	Flat with ribs
ZPR40 _{UC}	40	43	18.5	32	42.8	60.6	6	8	6	8	6.5	3.3
ZPR50 _{UC}	50	53	19.5	33	43.8	61.6	6	8	6	8	7.5	3.8

Deep style

Model	ϕA	ϕB	C	D	E	F	H: M6		H: M8		Y
							G	G	G	G	
ZPR40D	40	43	29	42.5	53.3	71.1	6	8	8	17	

Applicable tube

Applicable tube O.D.	ϕP	Q	R	ϕS
$\phi 6$	6	24.3	16.8	12.8
$\phi 8$	8	26.2	18.7	15.2

Lateral Vacuum Entry without Buffer Series ZPR

Connection	One-touch Fitting	Pad Style	Bellows
Vacuum Entry	Lateral	Mounting	Female Thread

Pad Diameters **ø6, ø8**

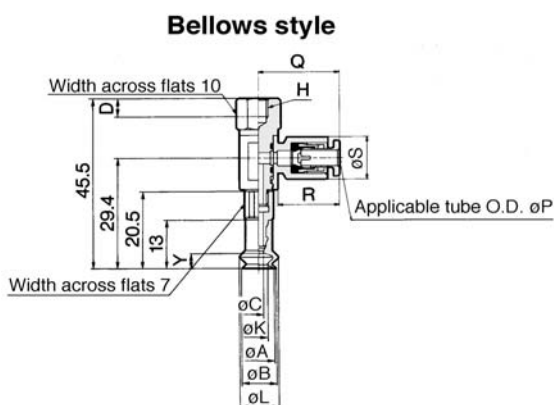

Model	øA	øB	øC	H: M4	H: M5	øK	øL	Y
				D	D			
ZPR06B	6	7	2.5	4	5	3.3	9.1	4
ZPR08B	8	9	2.5	4	5	4.7	10.1	4

Applicable tube

Applicable tube O.D.	øP	Q	R	øS
ø4	4	20.6	15.6	10.4
ø6	6	21.6	16.6	12.8

Pad Diameters **ø20, ø25, ø32**

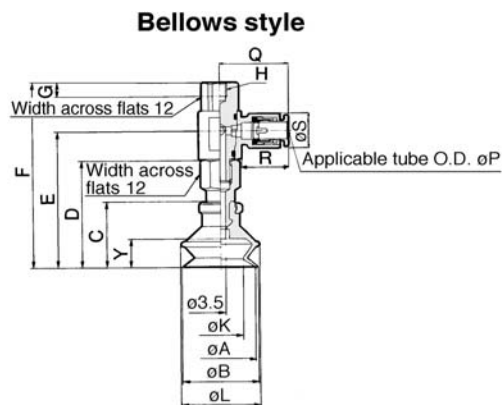

Model	øA	øB	C	D	E	F	H: M5	H: M6	H: M8	øK	øL	Y
							G	G	G			
ZPR20B	20	22	23.5	38.5	49.3	67.1	5	6	8	12.4	25	10.5
ZPR25B	25	27	24	39	49.8	67.6	5	6	8	15.6	28	10.5
ZPR32B	32	34	29	44	54.8	72.6	5	6	8	18.9	37	14

Applicable tube

Applicable tube O.D.	øP	Q	R	øS
ø4	4	23.3	15.8	10.4
ø6	6	24.3	16.8	12.8
ø8	8	26.2	18.7	15.2

Pad Diameters **ø10, ø13, ø16**

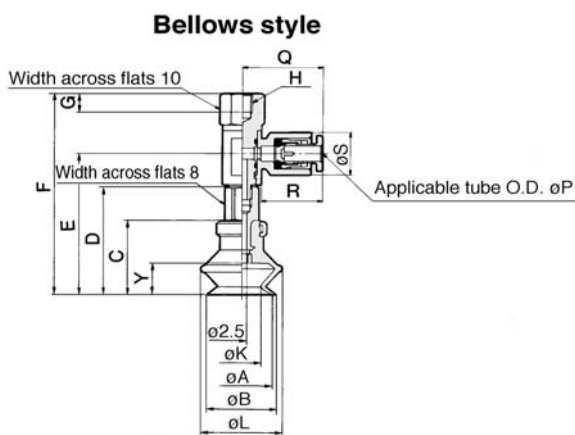

Model	øA	øB	C	D	E	F	H: M5	H: M6	øK	øL	Y
							G	G			
ZPR10B	10	12	16	25	33.9	50	5	6	5.5	13.8	5.5
ZPR13B	13	15	18.5	27.5	36.4	52.5	5	6	8.7	19	7.5
ZPR16B	16	18	20	29	37.9	54	5	6	9.9	21	8.5

Applicable tube

Applicable tube O.D.	øP	Q	R	øS
ø4	4	20.6	15.6	10.4
ø6	6	21.6	16.6	12.8

Pad Diameters **ø40, ø50**

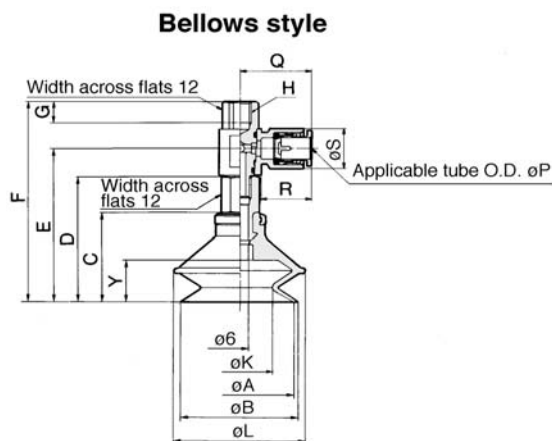

Model	øA	øB	C	D	E	F	H: M6	H: M8	øK	øL	Y
							G	G			
ZPR40B	40	43	34	47.5	58.3	76.1	6	8	24.4	48	16
ZPR50B	50	53	38	51.5	62.3	80.1	6	8	32.4	57	19

Applicable tube

Applicable tube O.D.	øP	Q	R	øS
ø6	6	24.3	16.8	12.8
ø8	8	26.2	18.7	15.2

- ZX
- ZR
- ZM
- ZY
- ZH
- ZU
- ZL
- ZF
- ZP
- ZCU
- CYV
- Vacuum related



ZPR

Lateral Vacuum Entry with Buffer With One-touch Fitting



Specifications

Vacuum entry	Direction		
	Connection	Lateral	
Applicable tube dia.	ø2 to ø8	With One-touch fitting ø4, ø6 tube	
	ø10 to ø16	ø4, ø6 tube	
	ø20 to ø32	ø4, ø6, ø8 tube	
	ø40 to ø50	ø4, ø8 tube	
Mounting	Thread dia.	ø2 to ø8	M8 X 1 Male thread
		ø10 to ø16	M10 X 1 Male thread
		ø20 to ø32	M10 X 1 Male thread
		ø40 to ø50	M14 X 1 Male thread
Buffer style		Rotating (J)/Non-rotating (K)	
Buffer stroke		For ø2 to ø8 — 6, 10, 15, 25mm For ø10 to ø32 — 10, 20, 30, 40, 50mm For ø40, ø50 — 10, 20, 30, 50mm	

Pad Style

Pad style	Flat	Flat with ribs	Deep	Bellows
Pad dia. ø(mm)	2, 4, 6, 8 10, 13, 16, 20 25, 32, 40, 50	10, 13, 16, 20 25, 32, 40, 50	10, 16, 25, 40	6, 8, 10, 13, 16, 20 25, 32, 40, 50
Material (colour)	NBR (Black), Silicon rubber (White), Urethane rubber (Brown), Fluorine rubber (Black with green mark) Conductive NBR (Black with one white mark), Conductive silicon rubber (Black with two white marks)			
Durometer	NBR (50°), Silicon rubber (40°), Urethane rubber/Fluorine rubber (60°) Conductive NBR (50°), Conductive silicon rubber (50°)			

Spring Reactive Force

Pad dia. (mm)	0 stroke	Stroke end
ø2 to ø8	0.8N	1.2N
ø10 to ø32	1.0N	3.0N
ø40, ø50	2.0N	5.0N

Weight Table

Stroke (mm)	Pad style Vacuum entry Model	Flat/Flat with ribs			Deep			Bellows		
		04	06	08	04	06	08	04	06	08
6	ZPR 02 to 08	38	39	—	—	—	—	38	39	—
	ZPR 10 to 16	39	40	—	39	40	—	40	41	—
10	ZPR 20 25	54	55	56	55	56	57	57	58	59
	ZPR 32	56	57	58	—	—	—	61	62	63
10	ZPR 40	—	126	127	—	128	129	—	138	139
	ZPR 50	—	132	133	—	—	—	—	145	146

Weight by Stroke

Stroke (mm)	10	15	20	25	30	40	50
ZPR02 to 08	+7	+8	—	+9	—	—	—
ZPR10 to 25	—	—	+12	—	+14	+26	+28
ZPR40, 50	—	—	-6	—	-2	—	+30



P.3.9-64 to 3.9-69

Lateral Vacuum Entry with Buffer Series ZPR

How to Order

Series ZPR
with buffer

ZPR 16 U GS K 20 06 A10

Pad dia. (mm)

02	ø2
04	ø4
06	ø6
08	ø8
10	ø10
13	ø13
16	ø16
20	ø20
25	ø25
32	ø32
40	ø40
50	ø50



(Refer to Table ① for applications.)

Pad style

U	Flat
C	Flat with ribs
D	Deep
B	Bellows

Buffer

J	Rotating
K	Non-rotating

Material

N	NBR
S	Silicon rubber
U	Urethane rubber
F	Fluorine rubber
GN*	Conductive NBR (ø2 to ø16)
GS*	Conductive silicon rubber (ø2 to ø16)

*ø20 or larger are manufactured upon receipt of order.

Mounting thread
(Refer to Table ③ for applications.)

Vacuum entry
(Refer to Table ③ for applications.)

Buffer stroke
(Refer to Table ③ for applications.)

Table ① Pad Dia. /Pad Style

Style \ Dia.(mm)	2	4	6	8	10	13	16	20	25	32	40	50
Flat	●	●	●	●	●	●	●	●	●	●	●	●
Flat with ribs	—	—	—	—	●	●	●	●	●	●	●	●
Deep	—	—	—	—	●	—	●	—	●	—	●	—
Bellows	—	—	●	●	●	●	●	●	●	●	●	●

Table ② Pad Dia. /Stroke

Stroke \ Dia.(mm)	2	4	6	8	10	13	16	20	25	32	40	50
6mm	●	●	●	●	—	—	—	—	—	—	—	—
10mm	●	●	●	●	●	—	●	●	●	●	●	●
15mm	●	●	●	●	—	—	—	—	—	—	—	—
20mm	—	—	—	—	●	●	●	●	●	●	●	●
25mm	●	●	●	●	—	—	—	—	—	—	—	—
30mm	—	—	—	—	●	●	●	●	●	●	●	●
40mm	—	—	—	—	●	●	●	●	●	●	—	—
50mm	—	—	—	—	●	●	●	●	●	●	●	●

Table ③ Vacuum Entry/Mounting Thread Dia.

	Symbol	Thread dia. /Port size	ø2 to ø8	ø10 to ø16	ø20 to ø32	ø40/ø50
Vacuum entry	One-touch fitting	04	ø4 tube	●	●	—
		06	ø6 tube	●	●	●
		08	ø8 tube	—	—	●
Mounting	Male thread	A8	M8 X 1	●	—	—
		A10	M10 X 1	—	●	●
		A14	M14 X 1	—	—	—

ZX

ZR

ZM

ZY

ZH

ZU

ZL

ZF

ZP

ZCU

CYV

Vacuum related

Lateral Vacuum Entry with Buffer Series ZPR

Connection	One-touch Fitting	Pad Style	Flat/Flat with Ribs/Deep
Vacuum Entry	Lateral	Mounting	Male Thread

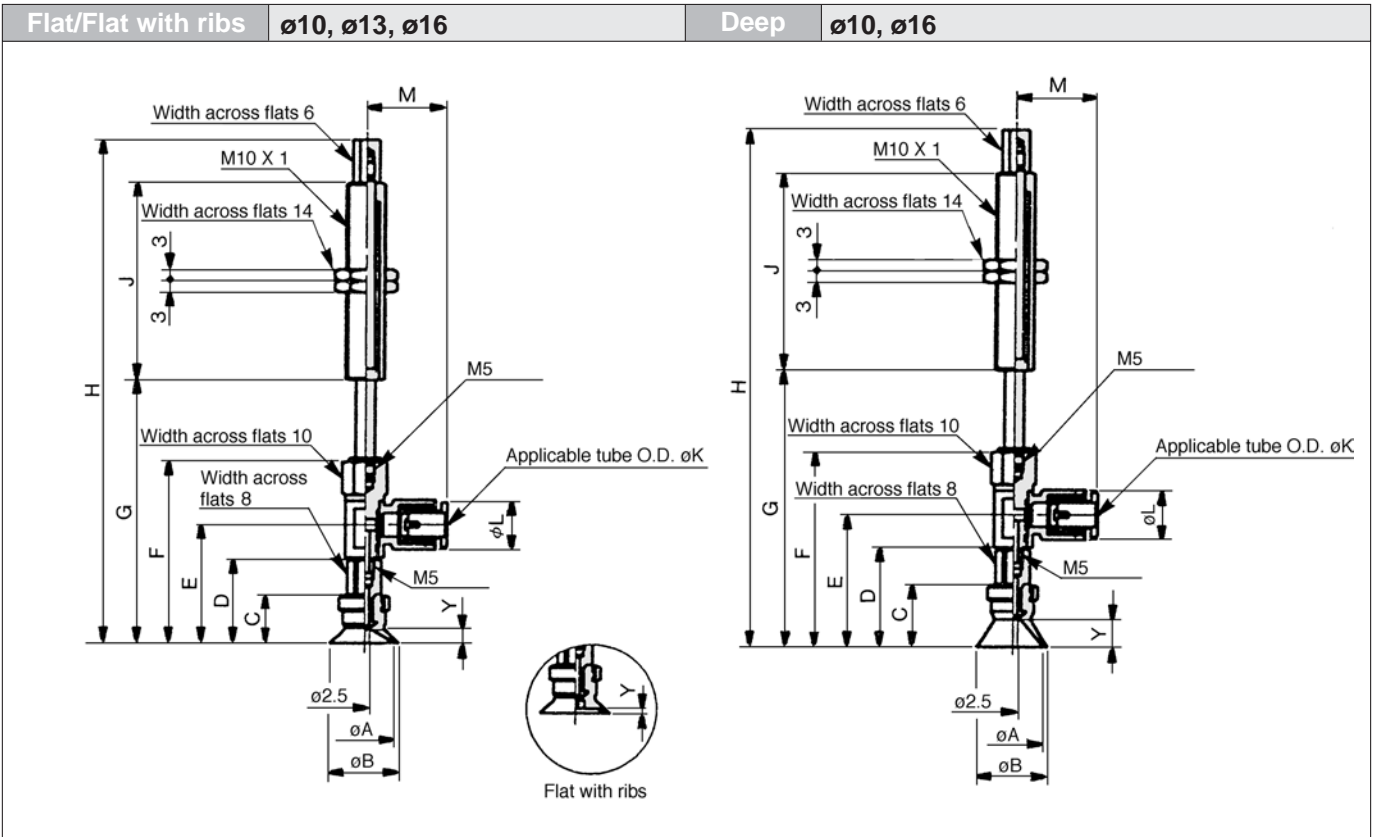

- ZX
- ZR
- ZM
- ZY
- ZH
- ZU
- ZL
- ZF
- ZP**
- ZCU
- CYV
- Vacuum related

Flat style/Flat with ribs

Model	A	B	C	D	E	F	Y	
							Flat	Flat w/ ribs
ZPR10 ^U _C □□□□□-0□A10	10	12	12	21	29.9	46	3	1.7
ZPR13 ^U _C □□□□□-0□A10	13	15	12	21	29.9	46	3	1.8
ZPR16 ^U _C □□□□□-0□A10	16	18	12.5	21.5	30.4	46.5	3.5	1.2

Dimensions by stroke

Model	ø10, ø13		ø16		J
	G	H	G	H	
ZPR□□ ^U _C □□□□-10□A10	57	91	57.5	91.5	23
ZPR□□ ^U _C □□□□-10□A10	67	129	67.5	129.5	51
ZPR□□ ^U _C □□□□-10□A10	77	139	77.5	139.5	
ZPR□□ ^U _C □□□□-10□A10	87	175	87.5	175.5	77
ZPR□□ ^U _C □□□□-10□A10	97	185	97.5	185.5	

Deep style

Model	A	B	C	D	E	F	Y
ZPR10D□□□□□-0□A10	10	12	15	24	32.9	49	6
ZPR16D□□□□□-0□A10	16	18	16	25	33.9	50	7

Dimensions by stroke

Model	ø10		ø16		J
	G	H	G	H	
ZPR□□D□□□□10-0□A10	60	83	61	84	23
ZPR□□D□□□□20-0□A10	70	132	71	133	51
ZPR□□D□□□□30-0□A10	80	142	81	143	
ZPR□□D□□□□40-0□A10	90	178	91	179	77
ZPR□□D□□□□50-0□A10	100	188	101	189	

One-touch fitting

Model	K	L	M
ZPR□□□□□□□□-04-A10	4	10.4	20.6
ZPR□□□□□□□□-06-A10	6	12.8	21.6

Series ZPR

Connection	One-touch Fitting	Pad Style	Flat/Flat with Ribs/Deep
Vacuum Entry	Lateral	Mounting	Male Thread

Flat/Flat with ribs	ø20, ø25, ø32	Deep	ø25
----------------------------	----------------------	-------------	------------

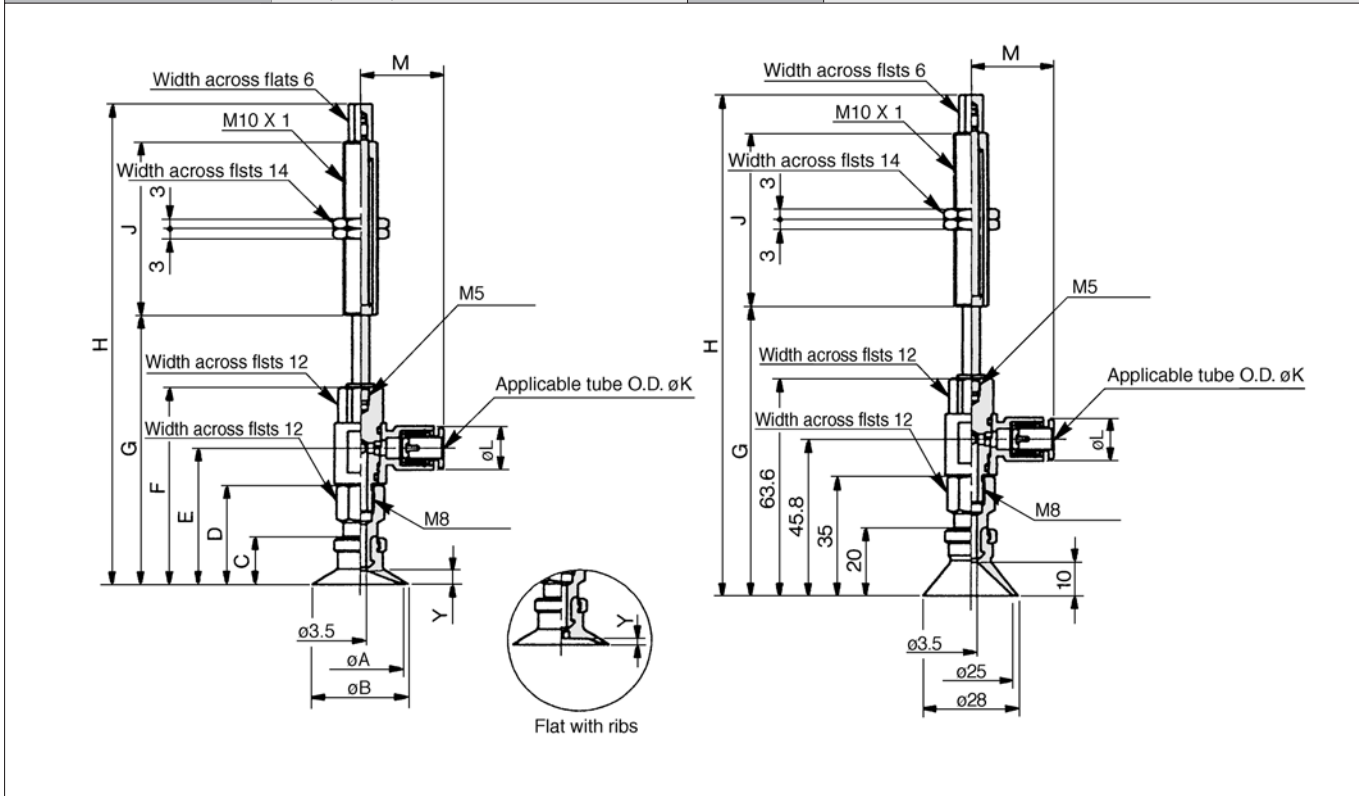

Flat style/Flat with ribs

Model	A	B	C	D	E	F	Y	
							Flat	Flat w/ ribs
ZPR20 ^U _C □□□□□-0□-A10	20	23	14	29	39.8	57.6	4	1.7
ZPR25 ^U _C □□□□□-0□-A10	25	28						1.8
ZPR22 ^U _C □□□□□-0□-A10	32	35	14.5	29.5	40.3	58.1	4.5	2.3

Dimensions by stroke

Model	ø20, ø25		ø32		J
	G	H	G	H	
ZPR□□ ^U _C □□□□□10-0□-A10	68.6	102.6	69.1	103.1	23
ZPR□□ ^U _C □□□□□20-0□-A10	78.6	140.6	79.1	141.1	51
ZPR□□ ^U _C □□□□□30-0□-A10	88.6	150.6	89.1	151.1	
ZPR□□ ^U _C □□□□□40-0□-A10	98.6	186.6	99.1	187.1	77
ZPR□□ ^U _C □□□□□50-0□-A10	108.6	196.6	109.6	197.1	

Deep style

Model	G	H	J
ZPR25D□□□□10-0□-A10	74.6	108.6	23
ZPR25D□□□□20-0□-A10	84.6	146.6	51
ZPR25D□□□□30-0□-A10	94.6	156.6	
ZPR25D□□□□40-0□-A10	104.6	192.6	77
ZPR25D□□□□50-0□-A10	114.6	202.6	

One-touch fitting

Model	K	L	M
ZPR□□□□□□□□-04-A10	4	10.4	23.3
ZPR□□□□□□□□-06-A10	6	12.8	24.3
ZPR□□□□□□□□-08-A10	8	15.2	26.2

Lateral Vacuum Entry with Buffer Series ZPR

Connection	One-touch Fitting	Pad Style	Flat/Flat with Ribs/Deep
Vacuum Entry	Lateral	Mounting	Male Thread

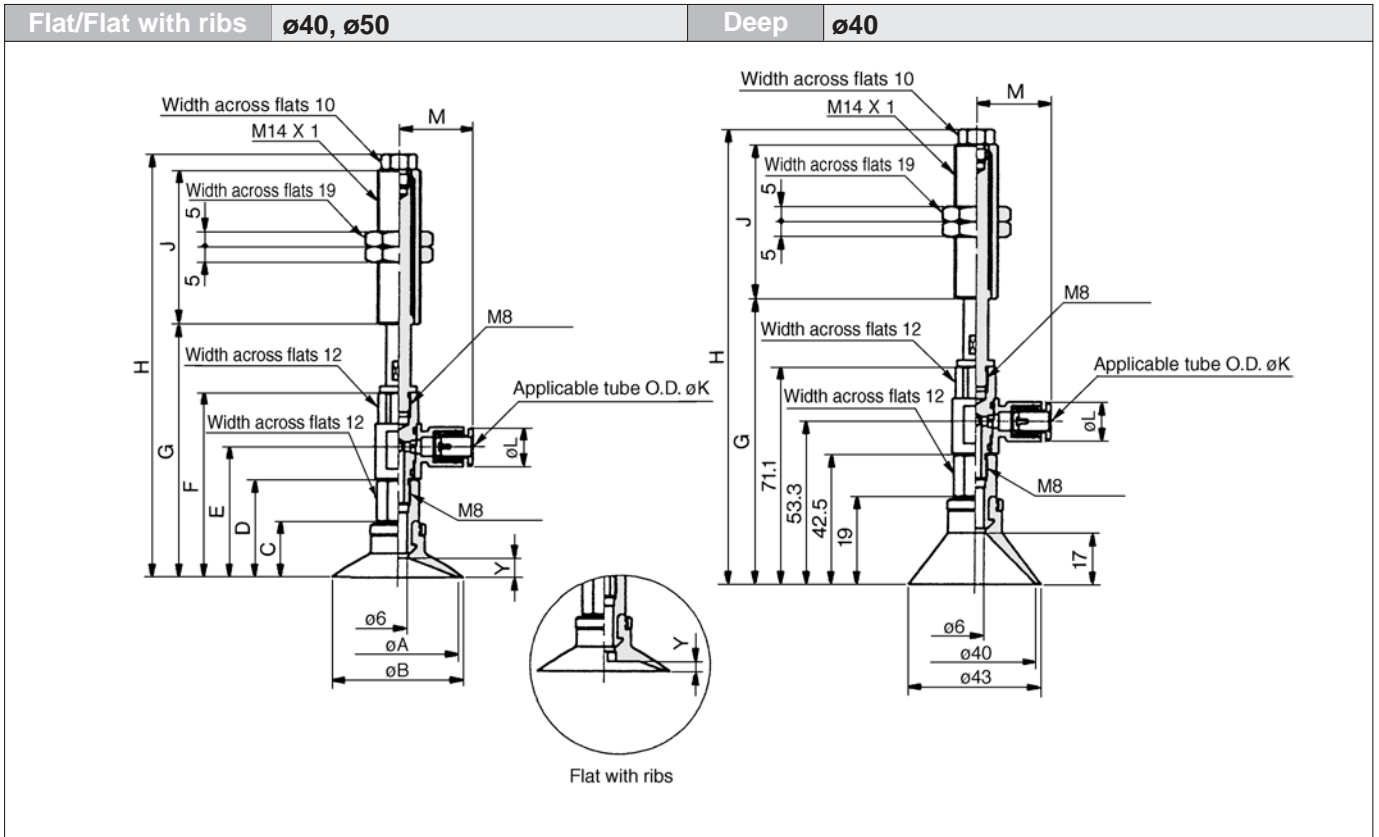

- ZX
- ZR
- ZM
- ZY
- ZH
- ZU
- ZL
- ZF
- ZP**
- ZCU
- CYV
- Vacuum related

Flat style/Flat with ribs

Model	A	B	C	D	E	F	Y	
							Flat	Flat w/ ribs
ZPR40 ^U _C □□□□-0□-A14	40	43	18.5	32	42.8	60.6	6.5	3.3
ZPR50 ^U _C □□□□-0□-A14	50	53	19.5	33	43.8	61.6	7.5	3.8

Dimensions by stroke

Model	ø40		ø32		J
	G	H	G	H	
ZPR□□ ^U _C □□□□10-0□-A14	72.6	140.6	73.6	141.6	50
ZPR□□ ^U _C □□□□20-0□-A14	82.6	137.6	83.6	138.6	
ZPR□□ ^U _C □□□□30-0□-A14	92.6	147.6	93.6	148.6	
ZPR□□ ^U _C □□□□50-0□-A14	112.6	192.6	113.6	193.6	

Deep style

Model	G	H	J
ZPR40D□□□□10-0□-A14	83.1	151.1	50
ZPR40D□□□□20-0□-A14	93.1	148.1	
ZPR40D□□□□30-0□-A14	103.1	158.1	
ZPR40D□□□□50-0□-A14	123.1	203.1	75

One-touch fitting

Model	K	L	M
ZPR□□□□□□□□-06-A14	6	12.8	24.3
ZPR□□□□□□□□-08-A14	8	15.2	26.2

Series ZPR

Connection	One-touch Fitting	Pad Style	Bellows
Vacuum Entry	Lateral	Mounting	Male Thread

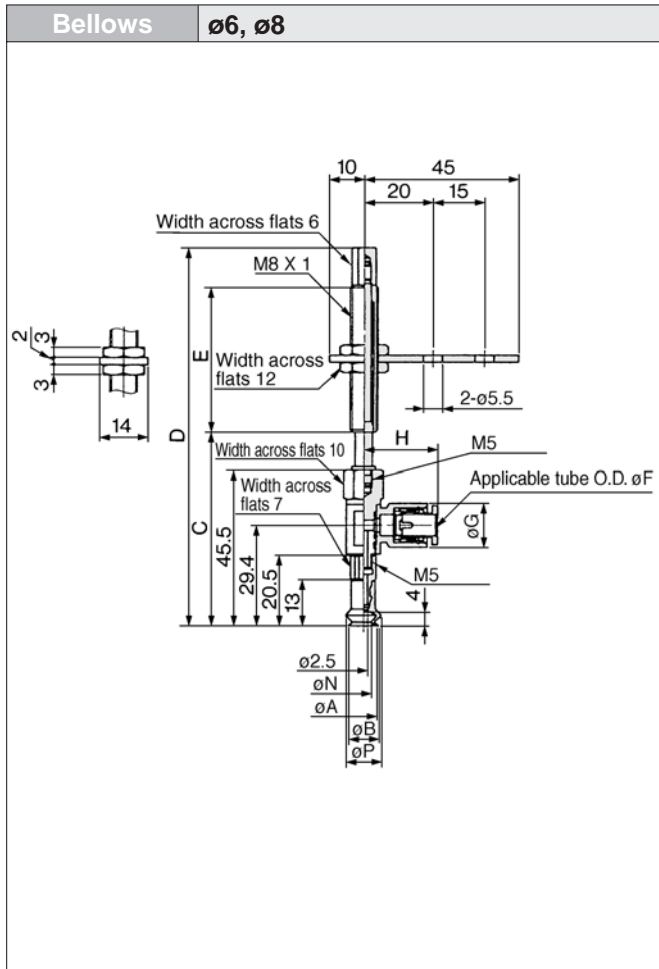

Bellows style

Model	A	B	N	P
ZPR06B□□□□-0□-A8	6	7	3.3	9.1
ZPR08B□□□□-0□-A8	8	9	4.7	10.1

Dimensions by stroke

Model	C	D	E	F: ø4		F: ø6	
				G	H	G	H
ZPR□□B□□□ 6-0□-A8	53.5	79.5	15				
ZPR□□B□□□10-0□-A8	56.5	110.5		10.4	20.6	12.8	21.6
ZPR□□B□□□15-0□-A8	61.5	115.5	43				
ZPR□□B□□□25-0□-A8	71.5	125.5					

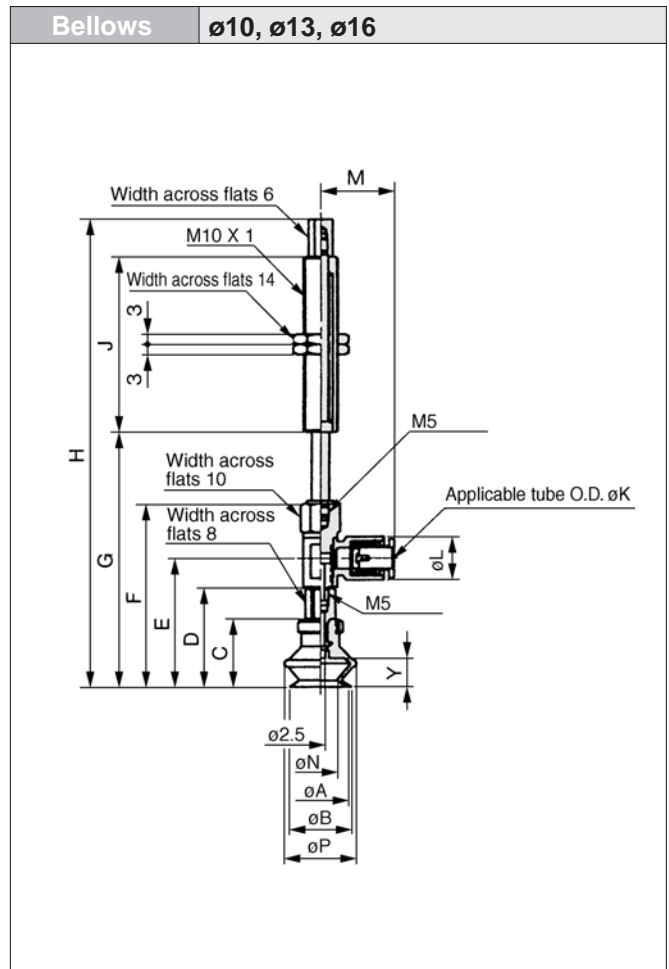

Bellows style

Model	A	B	C	D	E	F	N	P	Y
ZPR10B□□□□-0□-A10	10	12	16	25	33.9	50	5.5	13.8	5.5
ZPR13B□□□□-0□-A10	13	15	18.5	27.5	36.4	52.5	8.7	19	7.5
ZPR16B□□□□-0□-A10	16	18	20	29	37.9	54	9.9	21	8.5

Dimensions by stroke

Model	ø10		ø13		ø16		J	K: ø4		K: ø6	
	G	H	G	H	G	H		L	M	L	M
ZPR□□B□□□10-0□-A10	61	95	63.5	97.5	65	99	23				
ZPR□□B□□□20-0□-A10	71	133	73.5	135.5	75	137					
ZPR□□B□□□30-0□-A10	81	143	83.5	145.5	85	147	51	10.4	20.6	12.8	21.6
ZPR□□B□□□40-0□-A10	91	179	93.5	181.5	95	183					
ZPR□□B□□□50-0□-A10	101	189	103.5	191.5	105	193	77				

Lateral Vacuum Entry with Buffer Series ZPR

Connection	One-touch Fitting	Pad Style	Bellows
Vacuum Entry	Lateral	Mounting	Male Thread

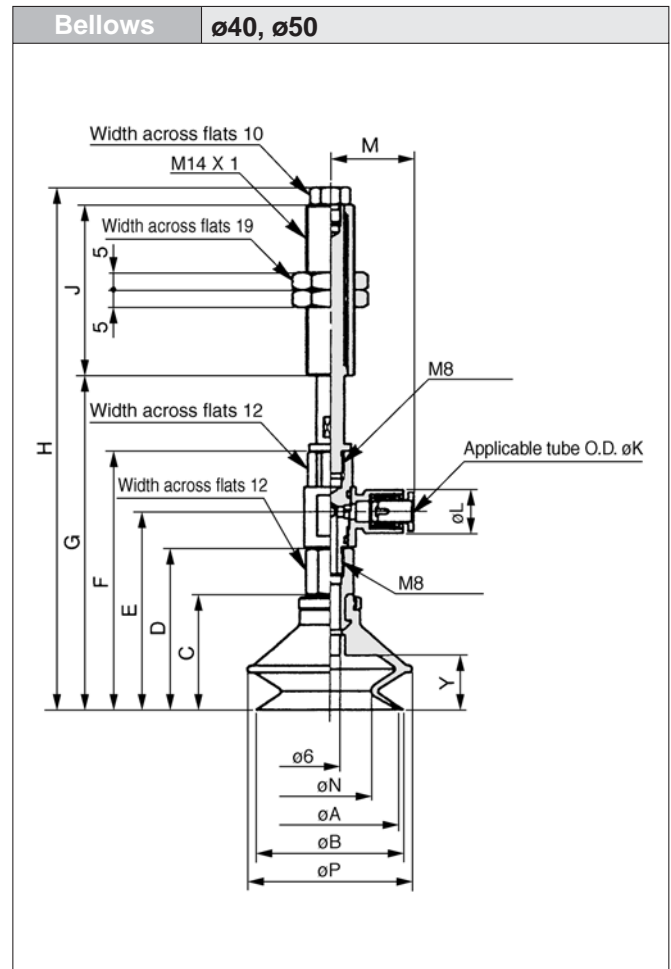
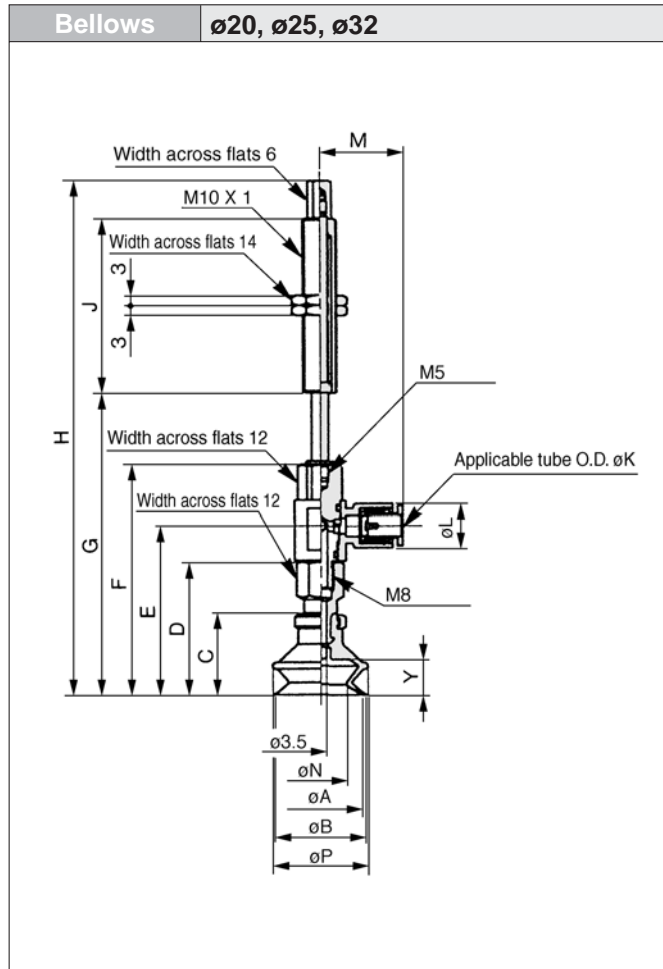

Bellows style

Model	A	B	C	D	E	F	N	P	Y
ZPR20B□□□□□-0□-A10	20	22	23.5	38.5	49.3	67.1	12.4	25	10.5
ZPR25B□□□□□-0□-A10	25	27	24	39	49.8	67.6	15.6	28	
ZPR32B□□□□□-0□-A10	32	34	29	44	54.8	72.6	18.9	37	

Bellows style

Model	A	B	C	D	E	F	N	P	Y
ZPR40B□□□□□-0□-A14	40	43	34	47.5	58.3	76.1	24.4	48	16
ZPR50B□□□□□-0□-A14	50	53	38	51.5	62.3	80.1	32.4	57	19

Dimensions by stroke

Model	ø20		ø25		ø32		J	K: ø4		K: ø6		K: ø8	
	G	H	G	H	G	H		L	M	L	M	L	M
	ZPR□□B□□□□10-0□-A10	78.1	112.1	78.6	112.6	83.6		117.6	23				
ZPR□□B□□□□20-0□-A10	88.1	150.1	88.6	150.6	93.6	155.6	51	10.4	23.3	12.8	24.3	15.2	26.2
ZPR□□B□□□□30-0□-A10	98.1	160.1	98.6	160.6	103.6	165.6							
ZPR□□B□□□□40-0□-A10	108.1	196.1	108.6	196.6	113.6	201.6	77						
ZPR□□B□□□□50-0□-A10	118.1	206.1	118.6	206.6	123.6	211.6							

Dimensions by stroke

Model	ø40		ø50		J	K: ø6		K: ø8	
	G	H	G	H		L	M	L	M
	ZPR□□B□□□□10-0□-A14	88.1	156.1	92.1		160.1	50	12.8	24.3
ZPR□□B□□□□20-0□-A14	98.1	153.1	102.1	157.1					
ZPR□□B□□□□30-0□-A14	108.1	163.1	112.1	167.1	75				
ZPR□□B□□□□50-0□-A14	128.1	208.1	132.1	212.1					

- ZX
- ZR
- ZM
- ZY
- ZH
- ZU
- ZL
- ZF
- ZP**
- ZCU
- CYV
- Vacuum related



ZPY

Lateral Vacuum Entry without Buffer With Barb Fitting



Specifications

Vacuum Entry	Direction	Lateral			
	Connection	With barb fitting			
	Applicable tube dia.	ø2 to ø8	ø4, ø6 Nylon tube, ø4, ø6 Urethane tube		
		ø10 to ø16	ø4, ø6 Nylon tube, ø4, ø6 Urethane tube		
		ø20 to ø32	ø4, ø6 Nylon tube, ø4, ø6 Urethane tube		
ø40, ø50		ø6 Nylon tube, ø6 Urethane tube			
Mounting	Connection	Male thread	Female thread		
	Thread dia.	ø2 to ø8	M5, M6	M4, M5	
		ø10 to ø16	M5, M6	M5, M6	
		ø20 to ø32	M6, M8 X 1	M5, M6, M8	
		ø40, ø50	M6, M8 X 1	M6, M8	

Pad Style

Pad style	Flat	Flat with ribs	Deep	Bellows
Pad dia. ø(mm)	2, 4, 6, 8, 10, 13, 16, 20, 25, 32, 40, 50	10, 13, 16, 20, 25, 32, 40, 50	10, 16, 25, 40,	6, 8, 10, 13, 16, 20, 25, 32, 40, 50
Material (colour)	NBR (Black), Silicon rubber (White), Urethane rubber (Brown), Fluorine rubber (Black with green mark) Conductive NBR (Black with one white mark), Conductive silicon rubber (Black with two white marks)			
Hardness	NBR (50°), Silicon rubber (40°), Urethane rubber/Fluorine rubber (60°) Conductive NBR (50°), Conductive silicon rubber (50°)			

Weight Table/Male Thread (Female Thread)

Model	Pad style		Flat			Flat with ribs			Deep			Bellows (g)		
	Connection	Connection	M5	M6	M8	M5	M6	M8	M5	M6	M8	M5	M6	M8
ZPY02 to ZPY08	15 (11)	15 (11)	—	—	—	—	—	—	—	—	—	15(11) except for ø2, ø4	15(11) except for ø2, ø4	—
ZPY10	—	—	—	—	—	—	—	—	31 (27)	33 (26)	—	—	—	—
ZPY13	32 (25)	33 (25)	—	32 (25)	33 (25)	—	—	—	—	—	—	— (25)	33 (25)	33 (—)
ZPY16	—	—	—	—	—	—	—	—	32 (27)	38 (27)	—	—	—	—
ZPY20	—	—	—	—	—	—	—	—	—	—	—	—	—	—
ZPY25	— (30)	38 (30)	38 (29)	38 (30)	38 (29)	—	—	—	— (30)	38 (30)	38 (28)	— (30)	38 (30)	38 (29)
ZPY32	—	—	—	—	—	—	—	—	—	—	—	—	—	—
ZPY40	—	43 (36)	47 (34)	—	42 (35)	46 (33)	—	—	—	44 (37)	48 (35)	—	43 (36)	47 (34)
ZPY50	—	44 (38)	49 (35)	—	46 (38)	50 (37)	—	—	—	—	—	—	44 (38)	49 (35)

*(): Figures for female thread connections.



P.3.9-64 to 3.9-69

Lateral Vacuum Entry without Buffer Series ZPY

Model

Model	Pad dia. ϕ (mm)	Pad style				Vacuum entry (Barb fitting)	Mounting thread	
		Flat (U)	Flat w/ ribs (C)	Deep (D)	Bellows (B)		Male thread	Female thread
ZPY02	2	●	—	—	—	● $\phi 4, \phi 6$ tube	● M5 M6	● M4 M5
ZPY04	4	●	—	—	—			
ZPY06	6	●	—	—	●			
ZPY08	8	●	—	—	●			
ZPY10	10	●	●	●	●			
ZPY13	13	●	●	—	●			
ZPY16	16	●	●	●	●	● $\phi 4, \phi 6$ tube	● M5 M6 M8	
ZPY20	20	●	●	—	●			
ZPY25	25	●	●	●	●			
ZPY32	32	●	●	—	●			
ZPY40	40	●	●	●	●			
ZPY50	50	●	●	—	●			
						● $\phi 6$ tube	● M6 M8 X 1	● M6 M8

How to Order

Series ZPY
without buffer

ZPY 02 U N — N4 — A5

Pad dia. (mm)

02	$\phi 2$
04	$\phi 4$
06	$\phi 6$
08	$\phi 8$
10	$\phi 10$
13	$\phi 13$
16	$\phi 16$
20	$\phi 20$
25	$\phi 25$
32	$\phi 32$
40	$\phi 40$
50	$\phi 50$



(Refer to Table ① for applications.)

Pad style

U	Flat
C	Flat with ribs
D	Deep
B	Bellows

Mounting thread



(Refer to Table ② for applications.)

Vacuum entry



(Refer to Table ② for applications.)

Table ② Vacuum Entry/Mounting Thread Dia.

Connection	Symbol	Thread Dia. /Port size	$\phi 2$ to $\phi 8$	$\phi 10$ to $\phi 16$	$\phi 20$ to $\phi 32$	$\phi 40, \phi 50$
Vacuum Entry	Barb fitting	N4	$\phi 4$ Nylon tube	●	●	—
		N6	$\phi 6$ Nylon tube	●	●	●
		U4	$\phi 4$ Urethane tube	●	●	●
		U6	$\phi 6$ Urethane tube	●	●	●
Mounting	Male thread	A5	M5	●	●	—
		A6	M6	●	●	●
		A8	M8 X 1	—	—	●
		B4	M4	●	—	—
	Female thread	B5	M5	●	●	—
		B6	M6	—	●	●
		B8	M8	—	—	●
		B8	M8	—	—	●

Material

N	NBR
S	Silicon rubber
U	Urethane rubber
F	Fluorine rubber
GN*	Conductive NBR ($\phi 2$ to $\phi 16$)
GS*	Conductive silicon rubber ($\phi 2$ to $\phi 16$)

* $\phi 20$ or larger are manufactured upon receipt of order.

Table ① Pad Dia. /Pad Style

Style \ Dia. (mm)	2	4	6	8	10	13	16	20	25	32	40	50
Flat	●	●	●	●	●	●	●	●	●	●	●	●
Flat with ribs	—	—	—	—	●	●	●	●	●	●	●	●
Deep	—	—	—	—	●	—	●	—	●	—	●	—
Bellows	—	—	●	●	●	●	●	●	●	●	●	●

ZX

ZR

ZM

ZY

ZH

ZU

ZL

ZF

ZP

ZCU

CYV

Vacuum related

Series ZPY

Connection	Barb Fitting	Pad Style	Flat/Flat with Ribs/Deep
Vacuum Entry	Lateral	Mounting	Male Thread

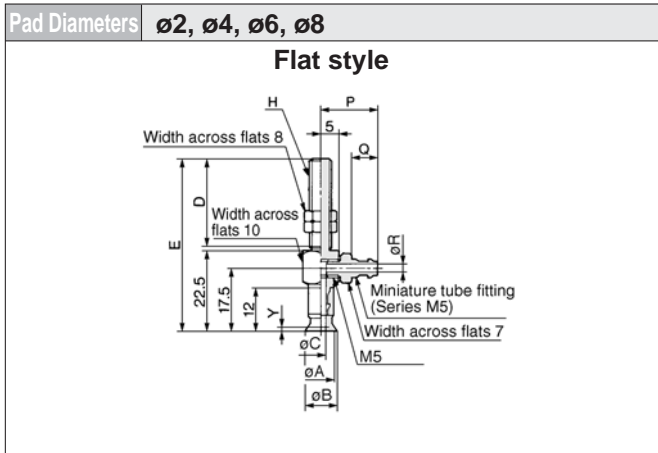

Model	ϕA	ϕB	C	D	E	H: M5		H: M6		Y	Applicable tube O.D	P	Q	ϕR
						F	G	F	G					
ZPY02U	2	2.6	1.2	20	44	25	49.5	0.8			N4 (Nylon tube $\phi 4, \phi 2.5$)	13.5	5	1.8
ZPY04U	4	4.8	1.6											
ZPY06U	6	7	2.5											
ZPY08U	8	9	2.5											
											U4 (Soft tube $\phi 4, \phi 2.5$)	13.5	5	1.8
											U6 (Soft tube $\phi 6, \phi 4$)	15.5	7	2.5

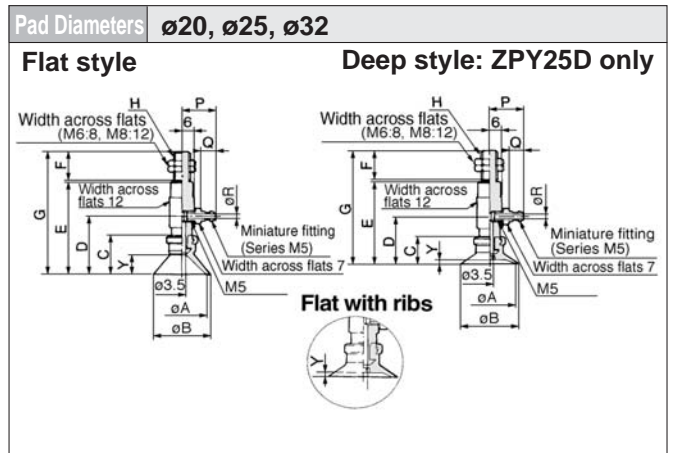

Model	ϕA	ϕB	C	D	E	H: M6		H: M8 X 1		Y		Applicable tube O.D	P	Q	ϕR
						F	G	F	G	Flat	Flat w/ ribs				
ZPY20 _U	20	23	14	24	42	25	68	15	58	4	1.7	N4 (Nylon tube $\phi 4, \phi 2.5$)	14.5	5	1.8
ZPY25 _U	25	28													
ZPY32 _U	32	35													
												N6 (Nylon tube $\phi 6, \phi 4$)	16.5	7	2.5
												U4 (Soft tube $\phi 4, \phi 2.5$)	14.5	5	1.8
												U6 (Soft tube $\phi 6, \phi 4$)	16.5	7	2.5

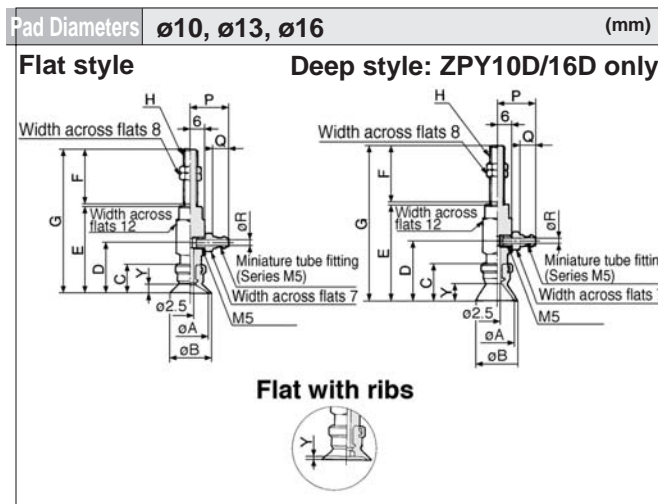

Model	ϕA	ϕB	C	D	E	H: M5		H: M6		Y		Applicable tube O.D	P	Q	ϕR
						F	G	F	G	Flat	Flat w/ ribs				
ZPY10 _U	10	12	12	22	38	20	59	25	64	3	1.7	N4 (Nylon tube $\phi 4, \phi 2.5$)	14.5	5	1.8
ZPY13 _U	13	15													
ZPY16 _U	16	18													
												N6 (Nylon tube $\phi 6, \phi 4$)	16.5	7	2.5
												U4 (Soft tube $\phi 4, \phi 2.5$)	14.5	5	1.8
												U6 (Soft tube $\phi 6, \phi 4$)	16.5	7	2.5

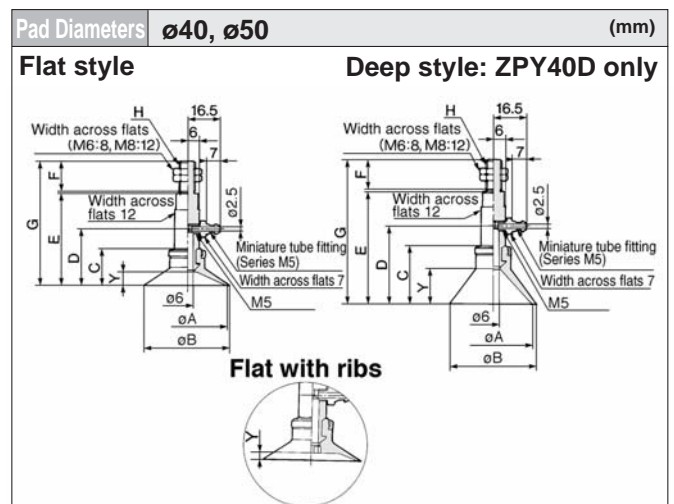

Model	ϕA	ϕB	C	D	E	H: M6		H: M8 X 1		Y		Applicable tube O.D	P	Q	ϕR
						F	G	F	G	Flat	Flat w/ ribs				
ZPY40 _U	40	43	18.5	28.5	46.5	25	72.5	15	62.5	6.5	3.3	N6 (Nylon tube $\phi 6, \phi 4$)	16.5	7	2.5
ZPY50 _U	50	53													
												U4 (Soft tube $\phi 4, \phi 2.5$)	14.5	5	1.8
												U6 (Soft tube $\phi 6, \phi 4$)	16.5	7	2.5

Lateral Vacuum Entry without Buffer Series ZPY

Connection	Barb Fitting	Pad Style	Bellows
Vacuum Entry	Lateral	Mounting	Male Thread

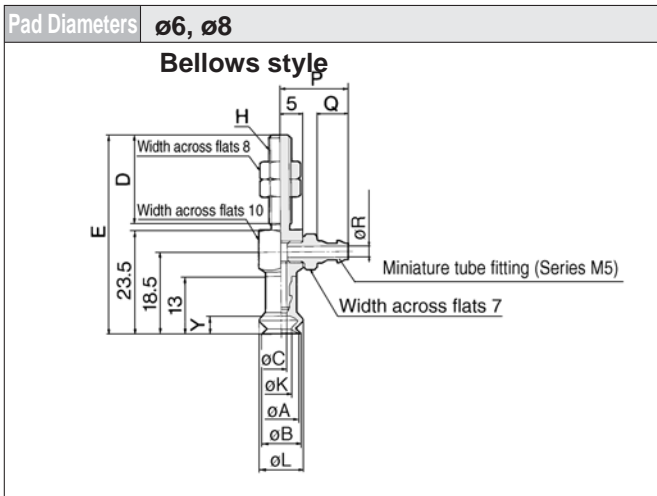

Model	øA	øB	øC	H: M5		H: M6		øK	øL	Y
				D	E	D	E			
ZPY06B	6	7	2.5	20	45	25	50.5	3.3	9.1	4
ZPY08B	8	9		4.7	10.1					

Applicable tube

Applicable tube	P	Q	øR
N4 (Nylon tube, ø4, ø2.5)	13.5	5	1.8
N6 (Nylon tube, ø6, ø4)	15.5	7	2.5
U4 (Urethane tube, ø4, ø2.5)	13.5	5	1.8
U6 (Urethane tube, ø6, ø4)	15.5	7	2.5

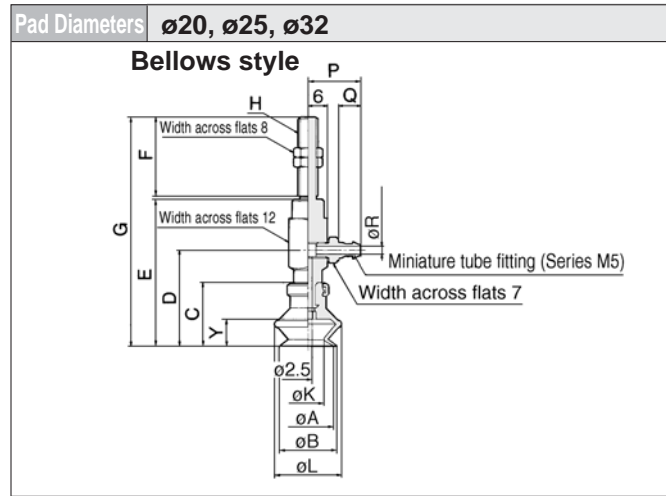

Model	øA	øB	C	D	E	H: M6		H: M8 X 1		øK	øL	Y
						F	G	F	G			
ZPY20B	20	22	23.5	33.5	51.5	25	79.5	69.5	12.4	25	10.5	
ZPY25B	25	27	24	34	52		80	15	70	15.6		28
ZPY32B	32	34	29	39	57		85	75	18.9	37		14

Applicable tube

Applicable tube	P	Q	øR
N4 (Nylon tube, ø4, ø2.5)	14.5	5	1.8
N6 (Nylon tube, ø6, ø4)	16.5	7	2.5
U4 (Urethane tube, ø4, ø2.5)	14.5	5	1.8
U6 (Urethane tube, ø6, ø4)	16.5	7	2.5

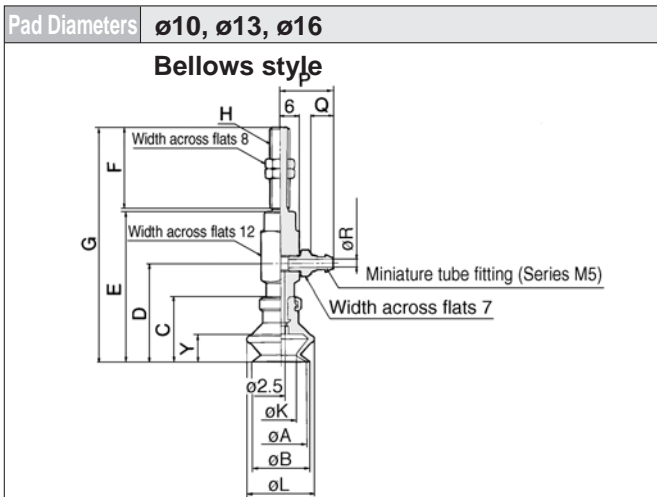

Model	øA	øB	C	D	E	H: M5		H: M6		øK	øL	Y
						F	G	F	G			
ZPY10B	10	12	16	26	42	20	63	68	5.5	13.8	5.5	
ZPY13B	13	15	18.5	28.5	44.5		65.5	25	70.5	8.7	19	7.5
ZPY16B	16	18	20	30	46		67	72	9.9	21	8.5	

Applicable tube

Applicable tube	P	Q	øR
N4 (Nylon tube, ø4, ø2.5)	14.5	5	1.8
N6 (Nylon tube, ø6, ø4)	16.5	7	2.5
U4 (Urethane tube, ø4, ø2.5)	14.5	5	1.8
U6 (Urethane tube, ø6, ø4)	16.5	7	2.5

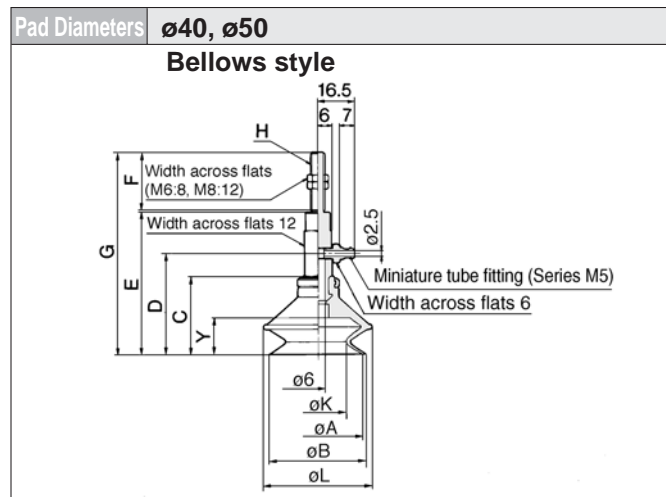

Model	øA	øB	C	D	E	H: M6		H: M8 X 1		øK	øL	Y
						F	G	F	G			
ZPY40B	40	43	34	44	62	25	88	78	24.4	48	16	
ZPY50B	50	53	38	48	66		92	15	82	32.4	57	19

- ZX
- ZR
- ZM
- ZY
- ZH
- ZU
- ZL
- ZF
- ZP
- ZCU
- CYV
- Vacuum related

Series ZPY

Connection	Barb Fitting	Pad Style	Flat/Flat with Ribs/Deep
Vacuum Entry	Lateral	Mounting	Female Thread

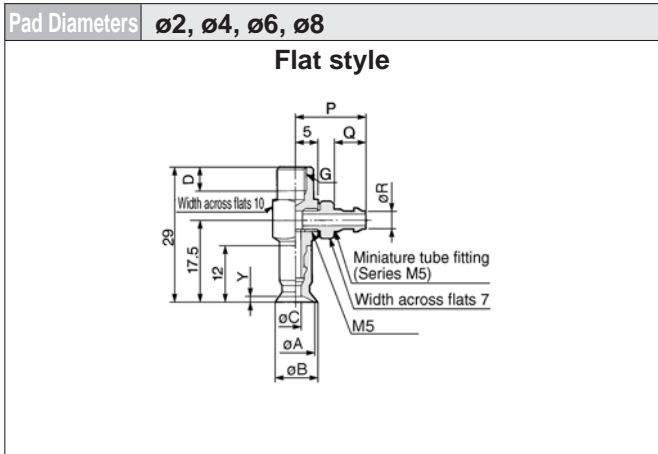

Flat style/Flat with ribs							Applicable tube			
Model	$\varnothing A$	$\varnothing B$	C	D	E	Y	Applicable tube O.D	P	Q	$\varnothing R$
ZPY02U	2	2.6	1.2	4	5	0.8	N4 (Nylon tube $\varnothing 4, \varnothing 2.5$)	13.5	5	1.8
ZPY04U	4	4.8	1.6							
ZPY06U	6	7	2.5							
ZPY08U	8	9	2.5							
							U4 (Soft tube $\varnothing 4, \varnothing 2.5$)	13.5	5	1.8
							U6 (Soft tube $\varnothing 6, \varnothing 4$)	15.5	7	2.5

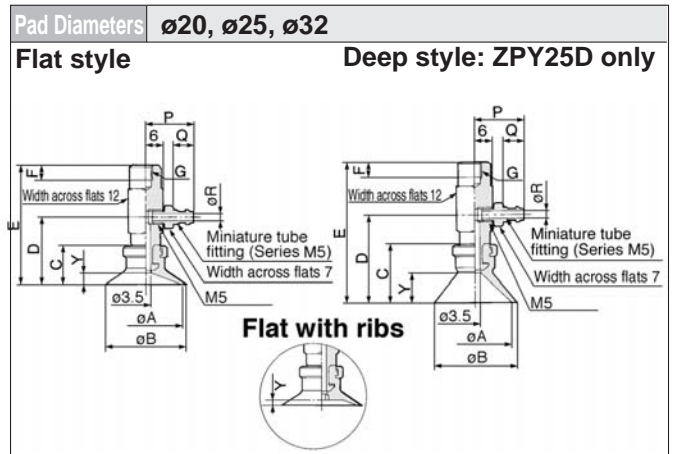

Flat style/Flat with ribs							Applicable tube			
Model	$\varnothing A$	$\varnothing B$	C	D	E	Y	Applicable tube O.D	P	Q	$\varnothing R$
ZPY20U	20	23	14	24	42	4	N4 (Nylon tube $\varnothing 4, \varnothing 2.5$)	14.5	5	1.8
ZPY25U	25	28	14	24	42					
ZPY32U	32	35	14.5	24.5	42.5					
							U4 (Soft tube $\varnothing 4, \varnothing 2.5$)	14.5	5	1.8
							U6 (Soft tube $\varnothing 6, \varnothing 4$)	16.5	7	2.5

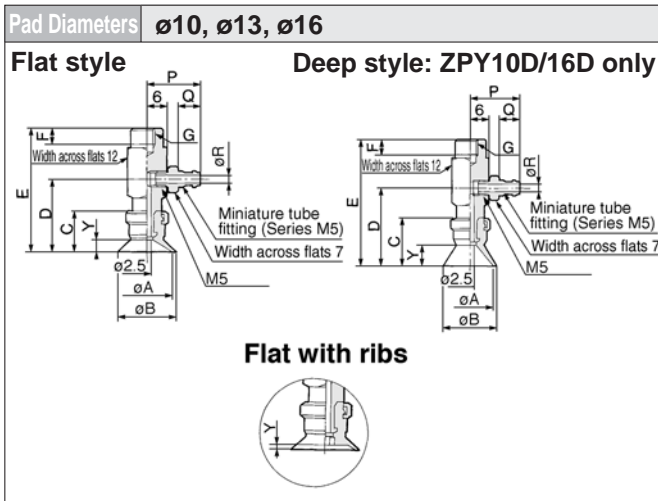

Flat style/Flat with ribs							Applicable tube			
Model	$\varnothing A$	$\varnothing B$	C	D	E	Y	Applicable tube O.D	P	Q	$\varnothing R$
ZPY10U	10	12	12	22	38	3	N4 (Nylon tube $\varnothing 4, \varnothing 2.5$)	14.5	5	1.8
ZPY13U	13	15	12	22	38					
ZPY16U	16	18	12.5	22.5	38.5					
							N6 (Nylon tube $\varnothing 6, \varnothing 4$)	16.5	7	2.5
							U4 (Soft tube $\varnothing 4, \varnothing 2.5$)	14.5	5	1.8
							U6 (Soft tube $\varnothing 6, \varnothing 4$)	16.5	7	2.5

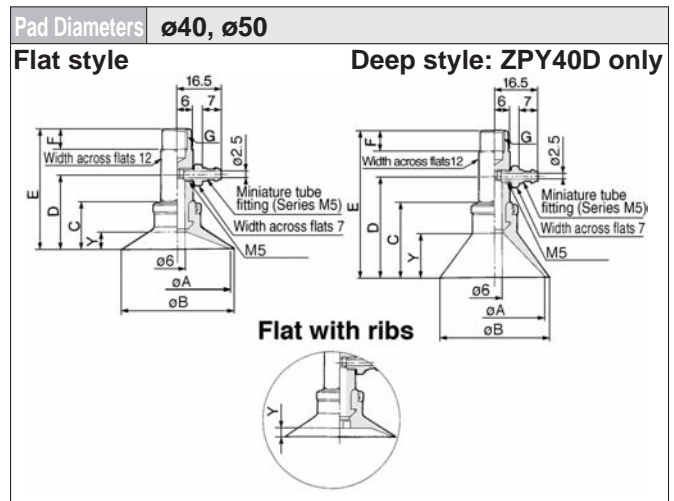

Flat style/Flat with ribs							Applicable tube			
Model	$\varnothing A$	$\varnothing B$	C	D	E	Y	Applicable tube O.D	P	Q	$\varnothing R$
ZPY40U	40	43	18.5	28.5	46.5	6.5	N4 (Nylon tube $\varnothing 4, \varnothing 2.5$)	14.5	5	1.8
ZPY50U	50	53	19.5	29.5	47.5					
							N6 (Nylon tube $\varnothing 6, \varnothing 4$)	16.5	7	2.5
							U4 (Soft tube $\varnothing 4, \varnothing 2.5$)	14.5	5	1.8
							U6 (Soft tube $\varnothing 6, \varnothing 4$)	16.5	7	2.5

Lateral Vacuum Entry without Buffer Series ZPY

Connection	Barb Fitting	Pad Style	Bellows
Vacuum Entry	Lateral	Mounting	Female Thread

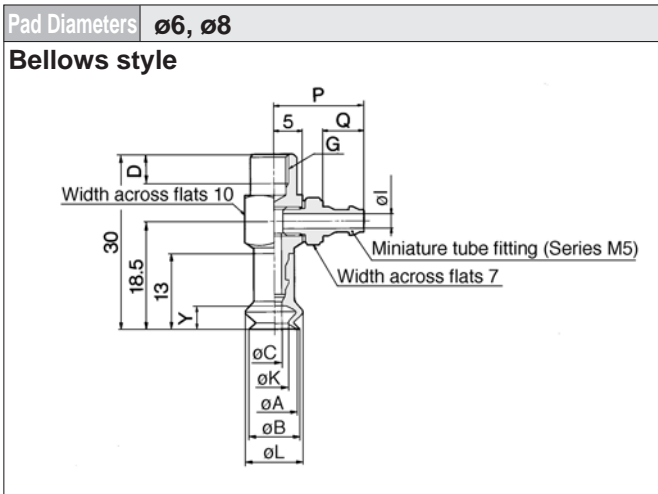

Model	ϕA	ϕB	ϕC	G: M4	G: M5	ϕK	ϕL	Y
				D	D			
ZPY06B	6	7	2.5	4	5	3.3	9.1	4
ZPY08B	8	9	2.5	4	5	4.7	10.1	4

Applicable tube

Applicable tube	P	Q	ϕR
N4 (Nylon tube, $\phi 4, \phi 2.5$)	13.5	5	1.8
N6 (Nylon tube, $\phi 6, \phi 4$)	15.5	7	2.5
U4 (Urethane tube, $\phi 4, \phi 2.5$)	13.5	5	1.8
U6 (Urethane tube, $\phi 6, \phi 4$)	15.5	7	2.5

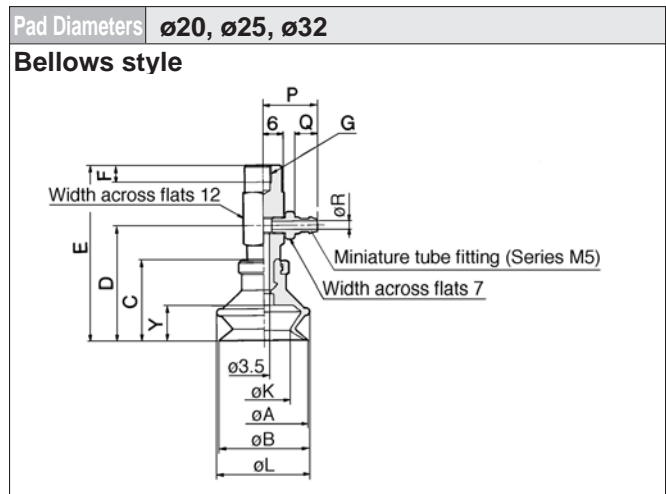

Model	ϕA	ϕB	C	D	E	G: M5	G: M6	G: M8	ϕK	ϕL	Y
						F	F	F			
ZPY20B	20	22	23.5	33.5	51.5				12.4	25	10.5
ZPY25B	25	27	24	34	52	5	6	8	15.6	28	10.5
ZPY32B	32	34	29	39	57				18.9	37	14

Applicable tube

Applicable tube	P	Q	ϕR
N4 (Nylon tube, $\phi 4, \phi 2.5$)	14.5	5	1.8
N6 (Nylon tube, $\phi 6, \phi 4$)	16.5	7	2.5
U4 (Urethane tube, $\phi 4, \phi 2.5$)	14.5	5	1.8
U6 (Urethane tube, $\phi 6, \phi 4$)	16.5	7	2.5

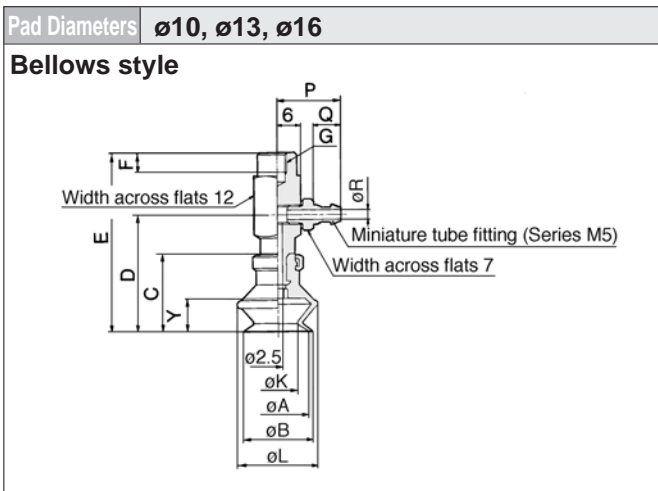

Model	ϕA	ϕB	C	D	E	G: M5	G: M6	ϕK	ϕL	Y
						F	F			
ZPY10B	10	12	16	26	42			5.5	13.8	5.5
ZPY13B	13	15	18.5	28.5	44.5	5	6	8.7	19	7.5
ZPY16B	16	18	20	30	46			9.9	21	8.5

Applicable tube

Applicable tube	P	Q	ϕR
N4 (Nylon tube, $\phi 4, \phi 2.5$)	14.5	5	1.8
N6 (Nylon tube, $\phi 6, \phi 4$)	16.5	7	2.5
U4 (Urethane tube, $\phi 4, \phi 2.5$)	14.5	5	1.8
U6 (Urethane tube, $\phi 6, \phi 4$)	16.5	7	2.5

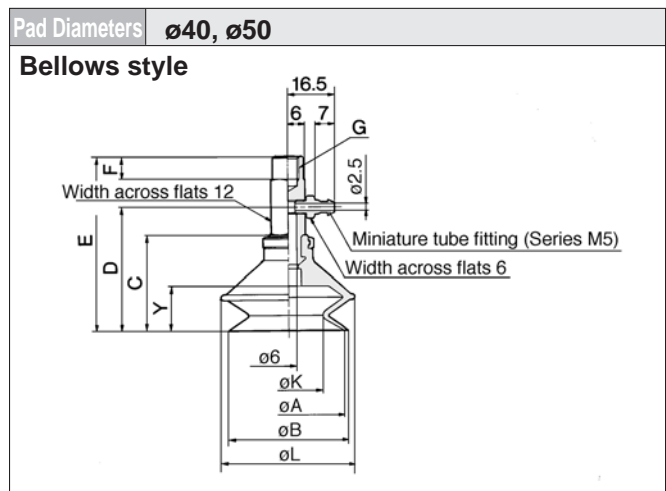

Model	ϕA	ϕB	C	D	E	G: M6	G: M8	ϕK	ϕL	Y
						F	F			
ZPY40B	40	43	34	44	62			24.4	48	16
ZPY50B	50	53	38	48	66	6	8	32.4	57	19

- ZX
- ZR
- ZM
- ZY
- ZH
- ZU
- ZL
- ZF
- ZP
- ZCU
- CYV
- Vacuum related

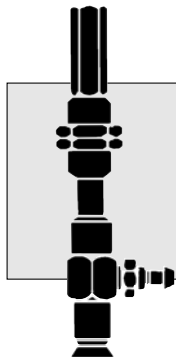

ZPY

Lateral Vacuum Entry with Buffer With Barb Fitting



Specifications

Vacuum entry	Direction Connection		Lateral
			With barb fitting
Applicable tube dia.	ø2 to ø8		ø4, ø6 Nylon tube, ø4, ø6 Urethane tube
	ø10 to ø16		ø4, ø6 Nylon tube, ø4, ø6 Urethane tube
	ø20 to ø32		ø4, ø6 Nylon tube, ø4, ø6 Urethane tube
	ø40, ø50		ø6 Nylon tube, ø6 Urethane tube
Mounting	Thread dia.	ø2 to ø8	M8 X 1 Male thread
		ø10 to ø16	M10 X 1 Male thread
		ø20 to ø32	M10 X 1 Male thread
		ø40, ø50	M14 X 1 Male thread
Buffer style		Rotating (J)/Non-rotating (K)	
Buffer stroke		ø2 to ø8 — 6mm	
		ø10 to ø50 — 10mm	

Pad Style

Pad style	Flat	Flat with ribs	Deep	Bellows
Pad dia. ø(mm)	2, 4, 6, 8, 10, 13, 16, 20, 25, 32, 40, 50	10, 13, 16, 20, 25, 32, 40, 50	10, 16, 25, 40	6, 8, 10, 13, 16, 20, 25, 32, 40, 50
Material (Colour)	NBR (Black), Silicon rubber (White), Urethane rubber (Brown), Fluorine rubber (Black with green mark) Conductive NBR (Black with one white mark), Conductive silicon rubber (Black with two white marks)			
Hardness	NBR (50°), Silicon rubber (40°), Urethane rubber/Fluorine rubber (60°) Conductive NBR (50°), Conductive silicon rubber (50°)			

Spring Reactive Force

Pad dia. (mm)	0 Stroke	Stroke end
ø2 to ø8	0.8N	1.2N
ø10 to ø32	1.0N	3.0N
ø40, ø50	2.0N	5.0N

Weight Table

Stroke (mm)	Pad				
	Model	Flat/ Flat w/ ribs	Deep	Bellows	
6	ZPY 02 to 08	33	—	33	
	ZPY 10 to 16	45	45	46	
10	ZPY 20 to 25	50	51	53	
	ZPY 32	52	—	58	
10	ZPY 40	115	117	127	
	ZPY 50	132	—	134	

Weight by Stroke

Model	Stroke (mm)						
	10	15	20	25	30	40	50
ZPY02 to 08	+7	+8	—	+9	—	—	—
ZPY10 to 25	—	—	+12	—	+14	+26	+28
ZPY40/50	—	—	-5.5	—	-1.5	—	+30



P.3.9-64 to 3.9-69

Lateral Vacuum Entry with Buffer Series ZPY

How to Order

Series **ZPY**
with buffer

ZPY 16 U GS K 20 U6 A10

Pad dia. (mm)

02	ø2
04	ø4
06	ø6
08	ø8
10	ø10
13	ø13
16	ø16
20	ø20
25	ø25
32	ø32
40	ø40
50	ø50



(Refer to Table ① for applications.)

Pad style

U	Flat
C	Flat with ribs
D	Deep
B	Bellows

Material

N	NBR
S	Silicon rubber
U	Urethane rubber
F	Fluorine rubber
GN*	Conductive NBR (ø2 to ø16)
GS*	Conductive silicon rubber (ø2 to ø16)

*ø20 or larger are manufactured upon receipt of order.



Buffer stroke
(Refer to Table ② for applications.)



Vacuum entry
(Refer to Table ③ for applications.)



Mounting thread
(Refer to Table ③ for applications.)

Table ① Pad Dia. /Pad Style

Style \ Dia. (mm)	2	4	6	8	10	13	16	20	25	32	40	50
Flat	●	●	●	●	●	●	●	●	●	●	●	●
Flat with ribs	—	—	—	—	●	●	●	●	●	●	●	●
Deep	—	—	—	—	●	—	●	—	●	—	●	—
Bellows	—	—	●	●	●	●	●	●	●	●	●	●

Table ② Pad Dia. /Stroke

Stroke \ Dia. (mm)	2	4	6	8	10	13	16	20	25	32	40	50
6mm	●	●	●	●	—	—	—	—	—	—	—	—
10mm	●	●	●	●	●	●	●	●	●	●	●	●
15mm	●	●	●	●	—	—	—	—	—	—	—	—
20mm	—	—	—	—	●	●	●	●	●	●	●	●
25mm	●	●	●	●	—	—	—	—	—	—	—	—
30mm	—	—	—	—	●	●	●	●	●	●	●	●
40mm	—	—	—	—	●	●	●	●	●	●	—	—
50mm	—	—	—	—	●	●	●	●	●	●	●	●

Table ③ Vacuum Entry/Mounting Thread Dia.

Vacuum entry	Symbol	Thread dia. /Port size	Dia.		
			ø2 to ø8	ø10 to ø32	ø40, ø50
Barb fitting	N4	ø4 Nylon tube	●	●	—
	N6	ø6 Nylon tube	●	●	●
	U4	ø4 Urethane tube	●	●	—
	U6	ø6 Urethane tube	●	●	●
Mate thread	A8	M8 X 1	●	—	—
	A10	M10 X 1	—	●	—
	A14	M14 X 1	—	—	●

- ZX
- ZR
- ZM
- ZY
- ZH
- ZU
- ZL
- ZF
- ZP
- ZCU
- CYV
- Vacuum related

Series ZPY

Connection	Barb Fitting	Pad Style	Flat
Vacuum Entry	Lateral	Mounting	Male Thread

Flat	ø2, ø4, ø6, ø8
-------------	-----------------------

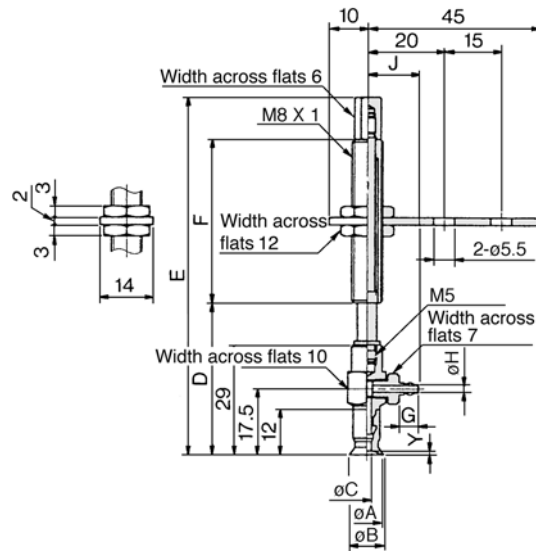

Flat style

Model	A	B	C	Y
ZPY02U□□□□□-□□- A8	2	2.6	1.2	0.8
ZPY04U□□□□□-□□- A8	4	4.8	1.6	
ZPY06U□□□□□-□□- A8	6	7	2.5	
ZPY08U□□□□□-□□- A8	8	9		

Dimensions by stroke

Model	D	E	F	ø4 tube			ø6 tube		
				G	H	J	G	H	J
ZPY□□U□□□□ 6-□□- A8	37	63	15	5	1.8	12.5	7	2.5	15.5
ZPY□□U□□□□10-□□- A8	40	94	43						
ZPY□□U□□□□15-□□- A8	45	99							
ZPY□□U□□□□25-□□- A8	55	109							

Series ZPY

Connection	Barb Fitting	Pad Style	Flat/Flat with Ribs/Deep
Vacuum Entry	Lateral	Mounting	Male Thread

Flat/Flat with ribs	ø20, ø25, ø32	Deep	ø25
----------------------------	----------------------	-------------	------------

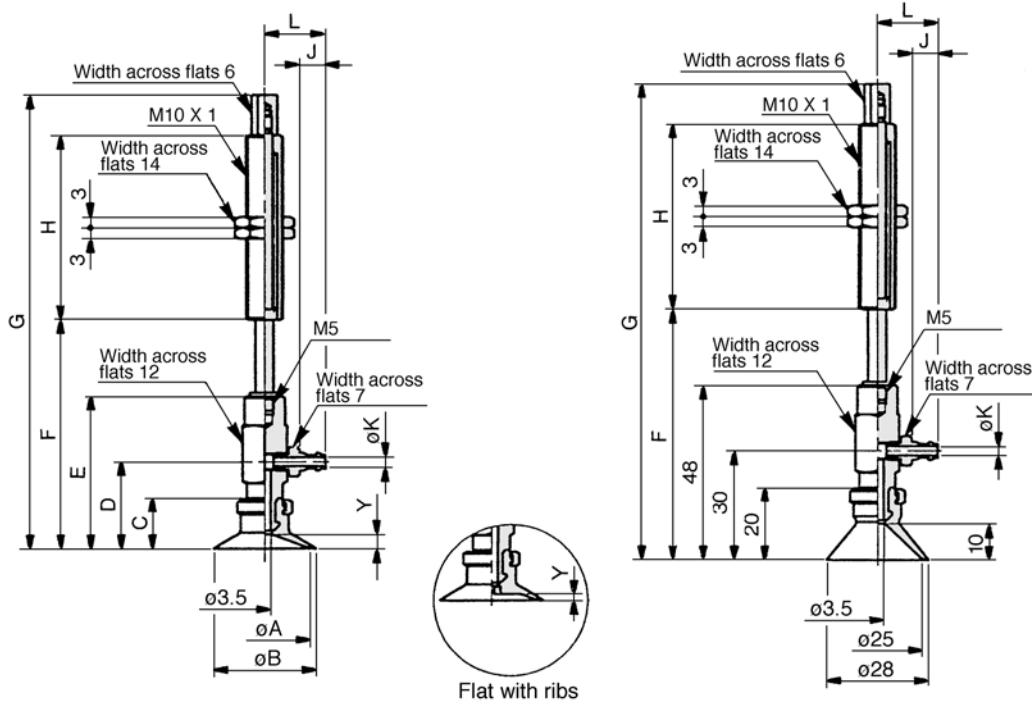

Flat style/Flat with ribs

Model	A	B	C	D	E	Y	
						Flat	Flat w/ ribs
ZPY20 ^U _C □□□□□-□□A10	20	23	14	24	42	4	1.7
ZPY25 ^U _C □□□□□-□□A10	25	28		1.8			
ZPY32 ^U _C □□□□□-□□A10	32	35	14.5	24.5	42.5	4.5	2.3

Dimensions by stroke

Model	ø20, ø25		ø32		H
	F	G	F	G	
ZPY□□ ^U _C □□□□□10-□□A10	53	87	53.5	87.5	23
ZPY□□ ^U _C □□□□□20-□□A10	63	125	63.5	125.5	51
ZPY□□ ^U _C □□□□□30-□□A10	73	135	73.5	135.5	
ZPY□□ ^U _C □□□□□40-□□A10	83	171	83.5	171.5	77
ZPY□□ ^U _C □□□□□50-□□A10	93	181	93.5	181.5	

Deep style

Model	F	G	H
ZPY25D□□□□10-□□A10	59	93	23
ZPY25D□□□□20-□□A10	69	131	51
ZPY25D□□□□30-□□A10	79	141	
ZPY25D□□□□40-□□A10	89	177	77
ZPY25D□□□□50-□□A10	99	187	

Dimensions by tube

Model	J	K	L
ZPY□□□□□□□□□□4-A10	5	1.8	14.5
ZPY□□□□□□□□□□6-A10	7	2.5	16.5

Series ZPY

Connection	Barb Fitting	Pad Style	Bellows
Vacuum Entry	Lateral	Mounting	Male Thread

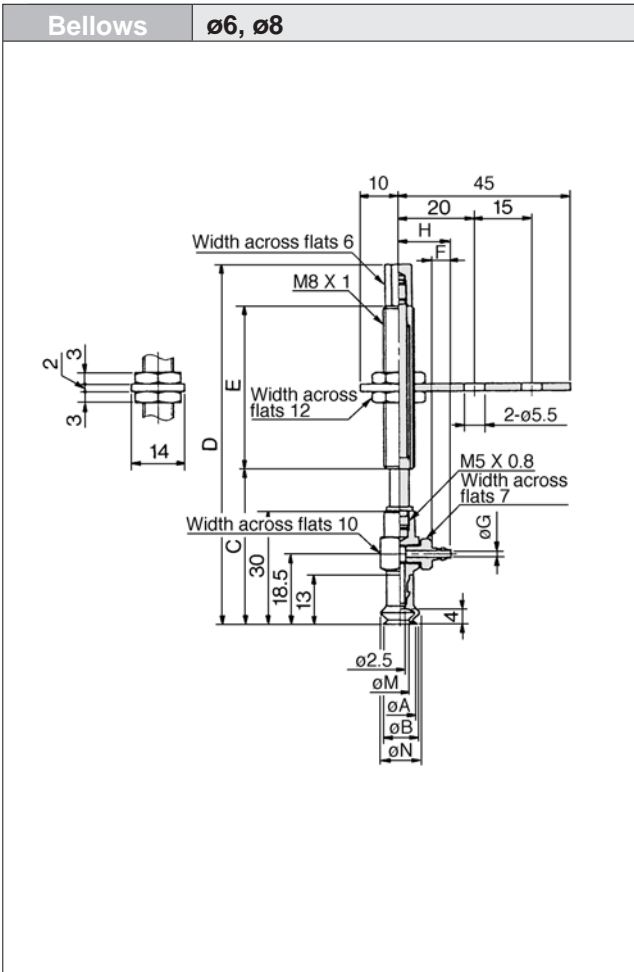

Bellows style

Model	A	B	M	N
ZPY06B□□□□-□□- A8	6	7	3.3	9.1
ZPY08B□□□□-□□- A8	8	9	4.7	10.1

Dimensions by stroke

Model	C	D	E	ø4 tube			ø6 tube		
				F	G	H	F	G	H
ZPY□□B□□□ 6-□□- A8	38	64	15						
ZPY□□B□□□10-□□- A8	41	95	43	5	1.8	13.5	7	2.5	15.5
ZPY□□B□□□15-□□- A8	46	100							
ZPY□□B□□□25-□□- A8	56	110							

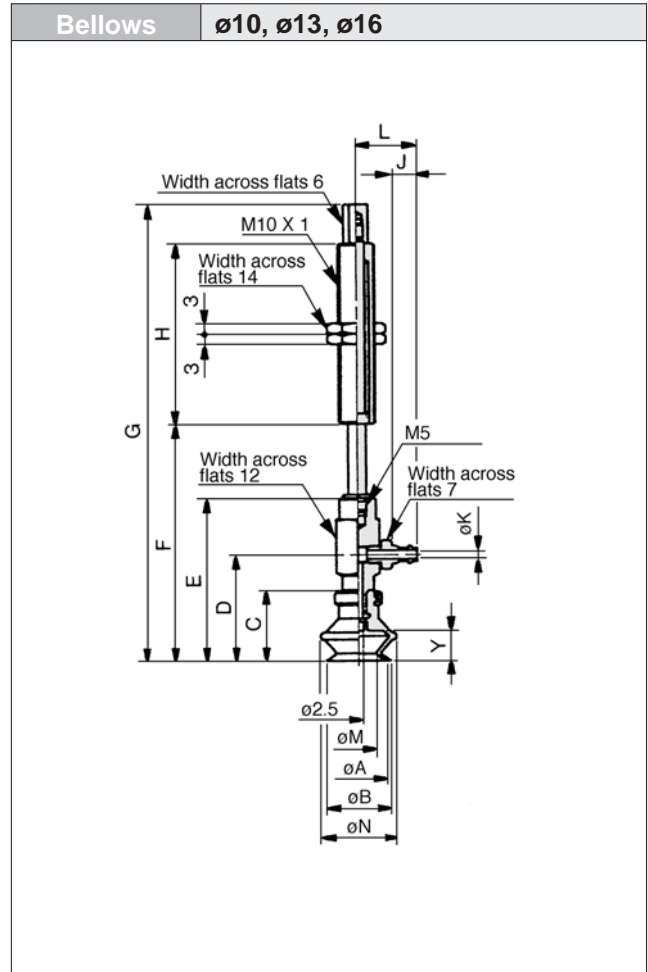

Bellows style

Model	A	B	C	D	E	M	N	Y
ZPY10B□□□□□-□□- A10	10	12	16	25	42	5.5	13.8	5.5
ZPY13B□□□□□-□□- A10	13	15	18.5	28.5	44.5	8.7	19	7.5
ZPY16B□□□□□-□□- A10	16	18	20	30	46	9.9	21	8.5

Dimensions by stroke

Model	ø10		ø13		ø16		H	ø4 tube			ø6 tube		
	F	G	F	G	F	G		J	K	L	J	K	L
ZPY□□B□□□10-□□- A10	53	87	55.5	89.5	57	91	23						
ZPY□□B□□□20-□□- A10	63	125	65.5	127.5	67	129	51	5	1.8	14.5	7	2.5	16.5
ZPY□□B□□□30-□□- A10	73	135	75.5	137.5	77	139							
ZPY□□B□□□40-□□- A10	83	171	85.5	173.5	87	175							
ZPY□□B□□□50-□□- A10	93	181	95.5	183.5	97	185	77						

Lateral Vacuum Entry with Buffer Series ZPY

Connection	Barb Fitting	Pad Style	Bellows
Vacuum Entry	Lateral	Mounting	Male Thread

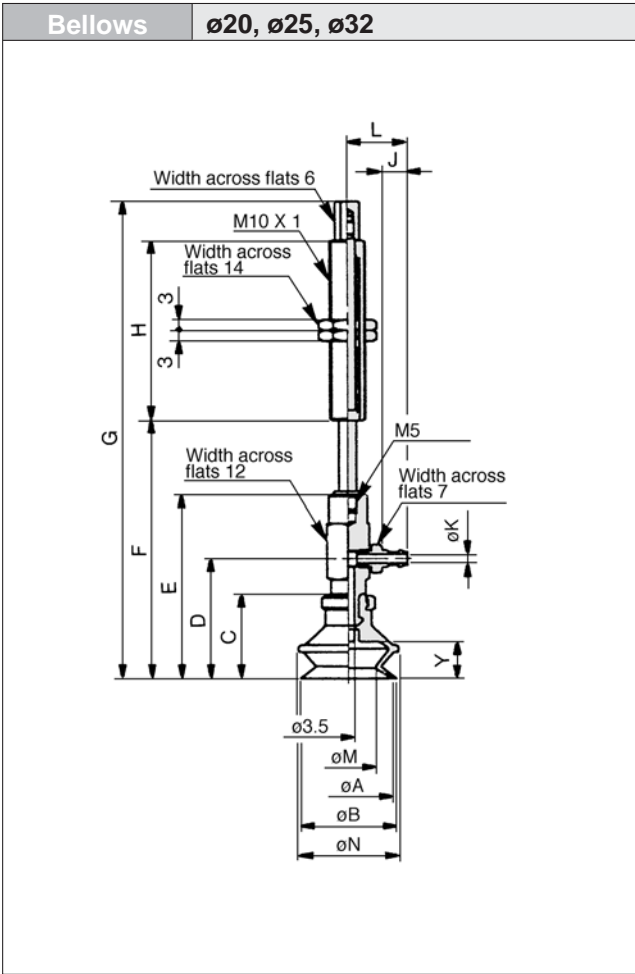

Bellows style

Model	A	B	C	D	E	M	N	Y
ZPY20B□□□□□□□□-A10	20	22	23.5	33.5	51.5	12.4	25	10.5
ZPY25B□□□□□□□□-A10	25	27	24	34	52	15.6	28	
ZPY32B□□□□□□□□-A10	32	34	29	39	57	18.9	37	

Dimensions by stroke

Model	ø20		ø25		ø32		H	ø4 tube			ø6 tube		
	F	G	F	G	F	G		J	K	L	J	K	L
	ZPY□□B□□□□10□□-A10	62.5	96.5	63	97	68		102	23				
ZPY□□B□□□□20□□-A10	74.5	136.5	75	137	80	142	51						
ZPY□□B□□□□30□□-A10	84.5	146.5	85	147	90	152		5	1.8	14.5	7	2.5	16.5
ZPY□□B□□□□40□□-A10	94.5	182.5	95	183	100	188	77						
ZPY□□B□□□□50□□-A10	104.5	192.5	105	193	110	198							

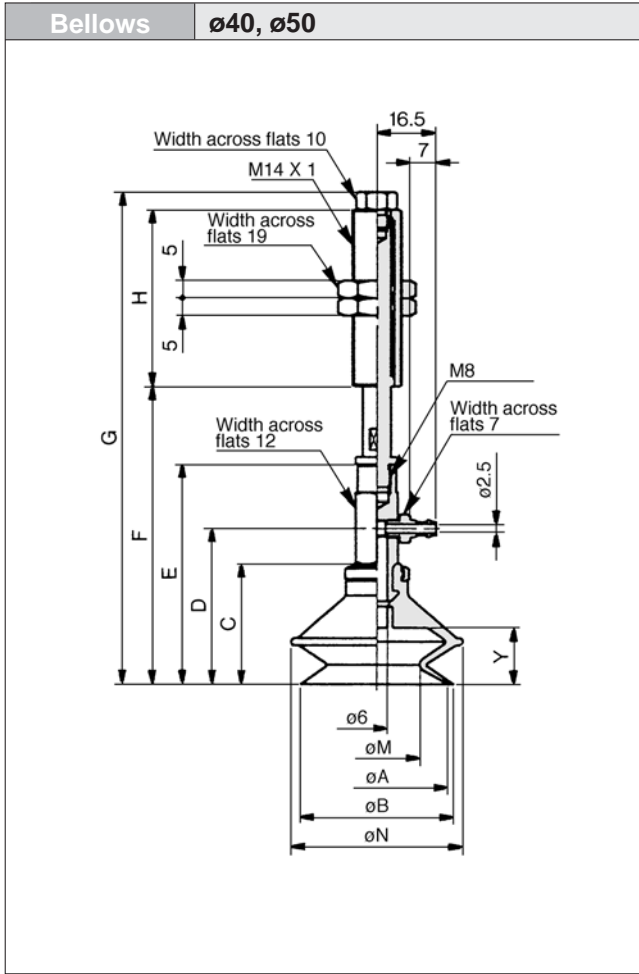

Bellows style

Model	A	B	C	D	E	M	N	Y
ZPY40B□□□□□□□□6-A14	40	43	34	44	62	24.4	48	16
ZPY50B□□□□□□□□6-A14	50	53	38	48	66	32.4	57	19

Dimensions by stroke

Model	ø40		ø50		H
	F	G	F	G	
ZPY□□B□□□□10□□6-A14	74	142	78	146	50
ZPY□□B□□□□20□□6-A14	84	139	88	143	
ZPY□□B□□□□30□□6-A14	94	149	98	153	
ZPY□□B□□□□50□□6-A14	114	194	118	198	

- ZX
- ZR
- ZM
- ZY
- ZH
- ZU
- ZL
- ZF
- ZP
- ZCU
- CYV
- Vacuum related

Vacuum Pad/Components

 Refer to p.3.9-61 for part nos. of ③ to ⑥.

Construction

Series ZPT

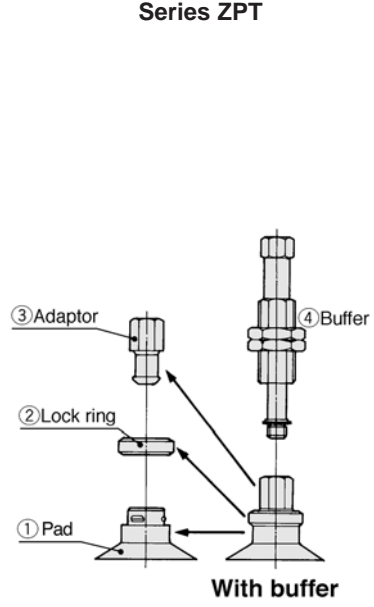

With buffer

Series ZPR

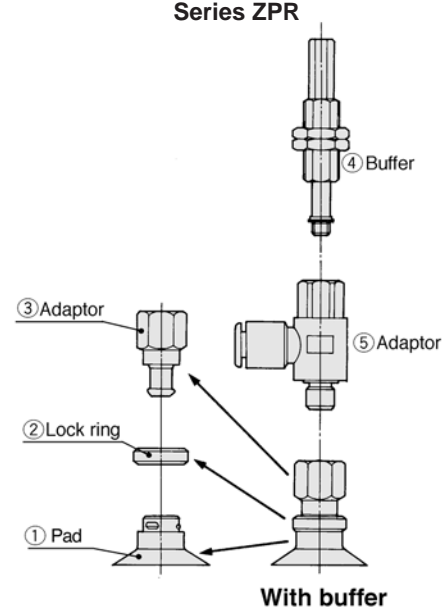

With buffer

Series ZPY

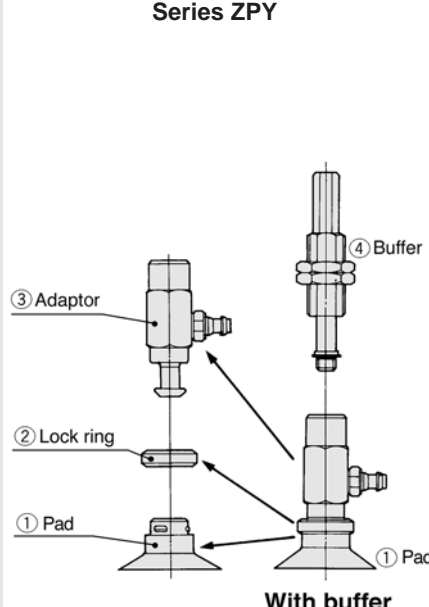

With buffer

Component Parts

No.	Description	Material	Note
①	Pad	Conductive NBR, Conductive silicon rubber, NBR, Silicon rubber, Urethane rubber, Fluorine rubber	
②	Lock ring	Brass	Electroless nickel plated
③	Adaptor	Brass	Electroless nickel plated
④	Buffer	Brass	Electroless nickel plated
⑤	Adaptor	Brass, PBT	Electroless nickel plated
⑥	Adaptor	Brass	Electroless nickel plated

Maintenance of Pad

Since pads are essentially rubber, deterioration is unavoidable. The rate of deterioration depends upon factors such as conditions of use, environment and temperature. Regular maintenance should be performed. If any damage, splitting, cracking or abrasion has occurred in a pad which appears to be harmful, replace it immediately. Also, take care not to damage the outside surface of the pad.

Replacement of Pad

- ① Pull the lock ring upward, and after lifting it to the adaptor, remove the old pad by pulling it downward.
- ② While holding the lock ring in the raised position, place a new pad onto the adaptor.
- ③ Confirm that the pad is securely in place, and then return the lock ring to its original position.

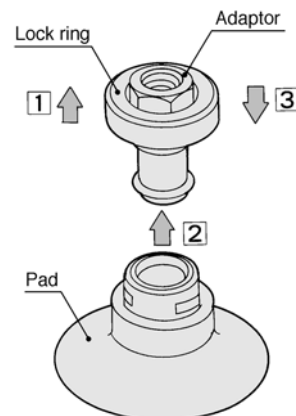
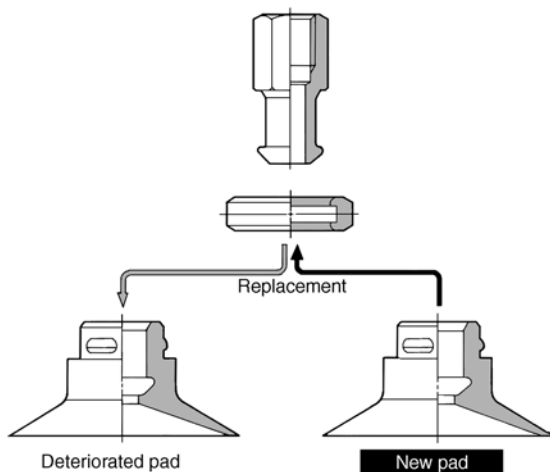

Replacement Parts: Pad unit (With lock ring/Without lock ring)

Pad Unit/How to Order

ZP 10 U N - X19

Pad diameter (mm)

02	ø2
04	ø4
06	ø6
08	ø8
10	ø10
13	ø13
16	ø16
20	ø20
25	ø25
32	ø32
40	ø40
50	ø50

Lock ring

—	With lock ring
-X19	Without lock ring (ø10 or larger)

Pad style

U	Flat
C	Flat with ribs
D	Deep
B	Bellows

Material

N	NBR
S	Silicon rubber
U	Urethane rubber
F	Fluorine rubber
GN*	Conductive NBR (ø2 to ø16)
GS*	Conductive silicon rubber (ø2 to ø16)

*ø20 or large are manufactured upon receipt of order.

Lock Ring Unit/How to Order

ZPL 1

Applicable pad dia. (mm)

1	ø10 to ø16
2	ø20 to ø32
3	ø40, ø50

ZX

ZR

ZM

ZY

ZH

ZU

ZL

ZF

ZP

ZCU

CYV

Vacuum related

Flat style (U)

ZP02U□ to 08U□

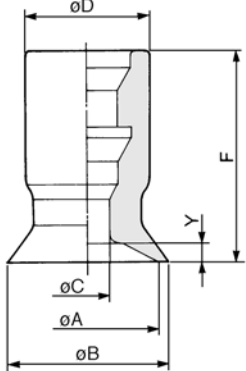

ZP10U□ to 50U□

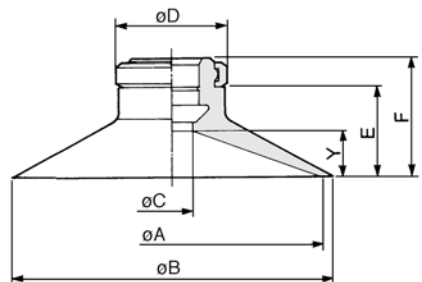

Model	Nom.size	øA	øB	øC	øD	E	F	Y
ZP02U□	U02	2	2.6	1.2	7	—	12	0.8
ZP04U□	U04	4	4.8	1.6	7	—	12	0.8
ZP06U□	U06	6	7	2.5	7	—	12	0.8
ZP08U□	U08	8	9	2.5	7	—	12	1
ZP10U□	U10	10	12	4	13	7.7	12	3
ZP13U□	U13	13	15	4	13	7.7	12	3
ZP16U□	U16	16	18	4	13	8.2	12.5	3.5
ZP20U□	U20	20	23	4	15	9.5	14	4
ZP25U□	U25	25	28	4	15	9.5	14	4
ZP32U□	U32	32	35	4	15	10	14.5	4.5
ZP40U□	U40	40	43	7	18	13.7	18.5	6.5
ZP50U□	U50	50	53	7	18	14.7	19.5	7.5

*Put in the symbol for material at the end of model no.

Flat with ribs (C)

ZP10C□ to 50C□

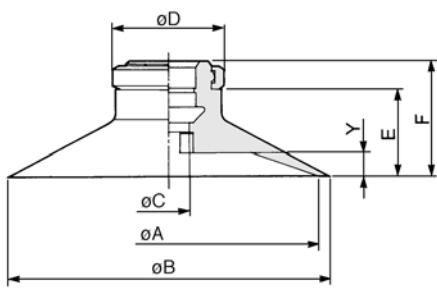

Model	Nom.size	øA	øB	øC	øD	E	F	Y
ZP10C□	C10	10	12	4	13	7.7	12	1.7
ZP13C□	C13	13	15	4	13	7.7	12	1.8
ZP16C□	C16	16	18	4	13	8.2	12.5	1.2
ZP20C□	C20	20	23	4	15	9.5	14	1.7
ZP25C□	C25	25	28	4	15	9.5	14	1.8
ZP32C□	C32	32	35	4	15	10	14.5	2.3
ZP40C□	C40	40	43	7	18	13.7	18.5	3.3
ZP50C□	C50	50	53	7	18	14.7	19.5	3.8

Deep style (D)

ZP10D□ to 40D□

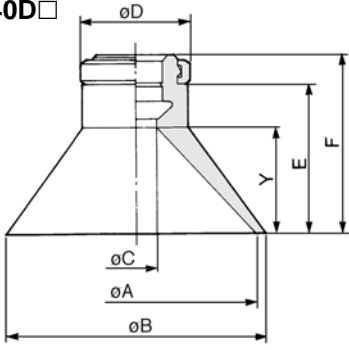

Model	Nom.size	øA	øB	øC	øD	E	F	Y
ZP10D□	D10	10	12	4	13	10.7	15	6
ZP16D□	D16	16	18	4	13	11.7	16	7
ZP25D□	D25	25	28	4	15	15.5	20	10
ZP40D□	D40	40	43	7	18	24.2	29	17

Replacement Parts: Pad Unit (With lock ring/Without lock ring)

Bellows (B)/With lock ring

Pad diameter: $\varnothing 6$ to $\varnothing 8$

ZP06B□ to 08B□

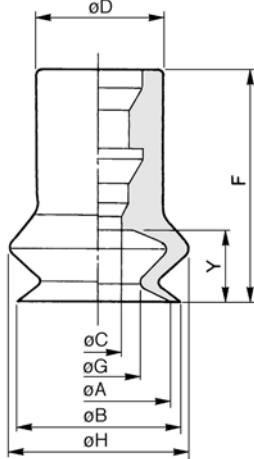

Pad diameter: $\varnothing 10$ to $\varnothing 50$

ZP10B□ to 50B□

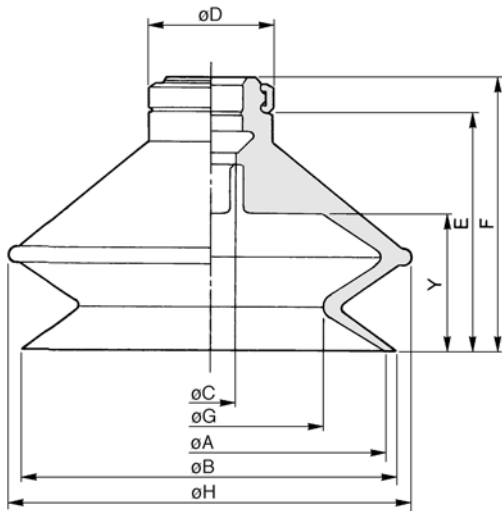

Model	Nom.size	$\varnothing A$	$\varnothing B$	$\varnothing C$	$\varnothing D$	E	F	$\varnothing G$	$\varnothing H$	Y
ZP06B□	B06	6	7	2.5	7	—	13	3.3	9.1	4
ZP08B□	B08	8	9	2.5	7	—	13	4.7	10.1	4
ZP10B□	B10	10	12	4	13	11.7	16	5.5	13.8	5.5
ZP13B□	B13	13	15	4	13	14.2	18.5	8.7	19	7.5
ZP16B□	B16	16	18	4	13	15.7	20	9.9	21	8.5
ZP20B□	B20	20	22	4	15	19	23.5	12.4	25	10.5
ZP25B□	B25	25	27	4	15	19.5	24	15.6	28	10.5
ZP32B□	B32	32	34	4	15	24.5	29	18.9	37	14
ZP40B□	B40	40	43	7	18	29.2	34	24.4	48	16
ZP50B□	B50	50	53	7	18	33.2	38	32.4	57	19

*Put in the symbol for material at the end of model no.

Buffer mounting nut

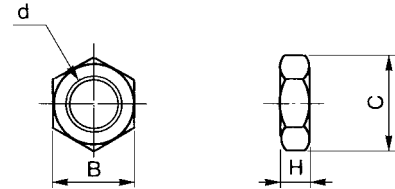

Model	Pad diameter	d	H	B	C
SNJ-010A	$\varnothing 2$ to $\varnothing 8$	M8 X 1	3	12	13.9
SNJ-015A	$\varnothing 10$ to $\varnothing 32$	M10 X 1	3	14	16.2
SN-015A	$\varnothing 40, \varnothing 50$	M14 X 1	5	19	21.9

Replacement Parts: Adaptor/Buffer (Series ZPT)

Appropriate adaptor or buffer can be selected for the currently used pad model.

Without Buffer

— The same symbol
 ←--- Replacement of the symbol

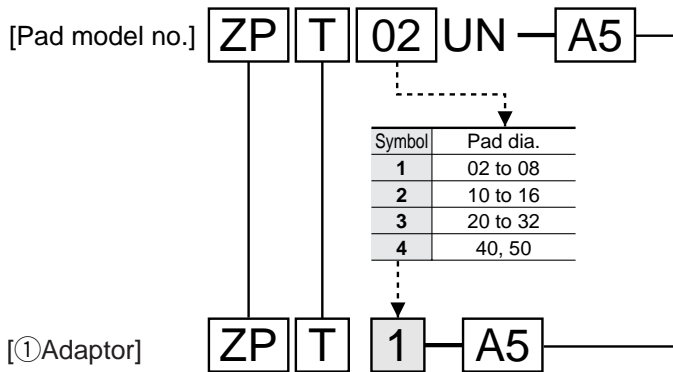
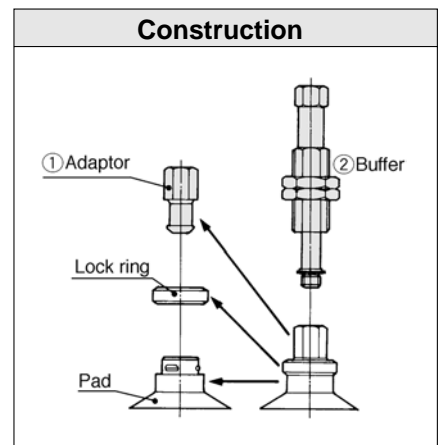

With Buffer

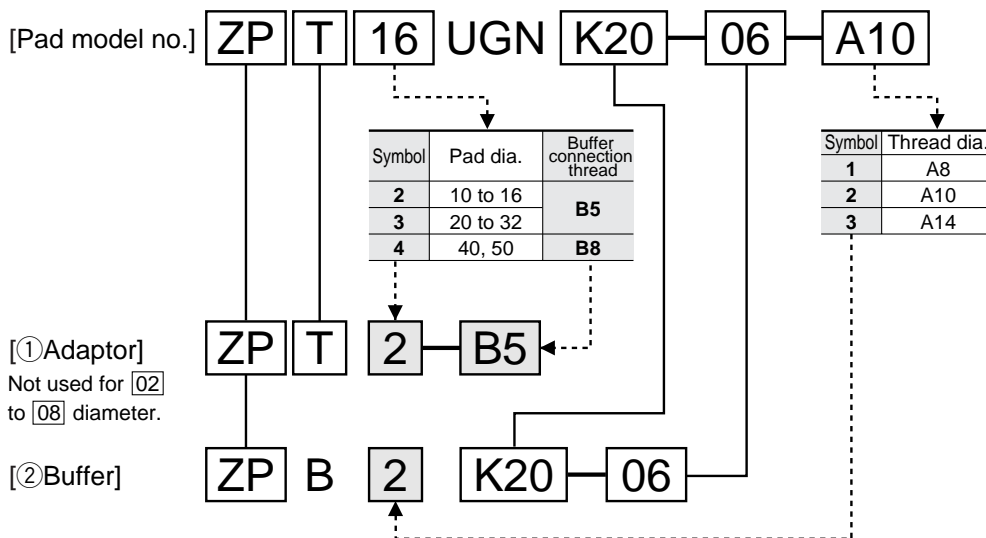

- ZX
- ZR
- ZM
- ZY
- ZH
- ZU
- ZL
- ZF
- ZP**
- ZCU
- CYV
- Vacuum related

Series ZP

Replacement Parts: Adaptor/Buffer (Series ZPR)

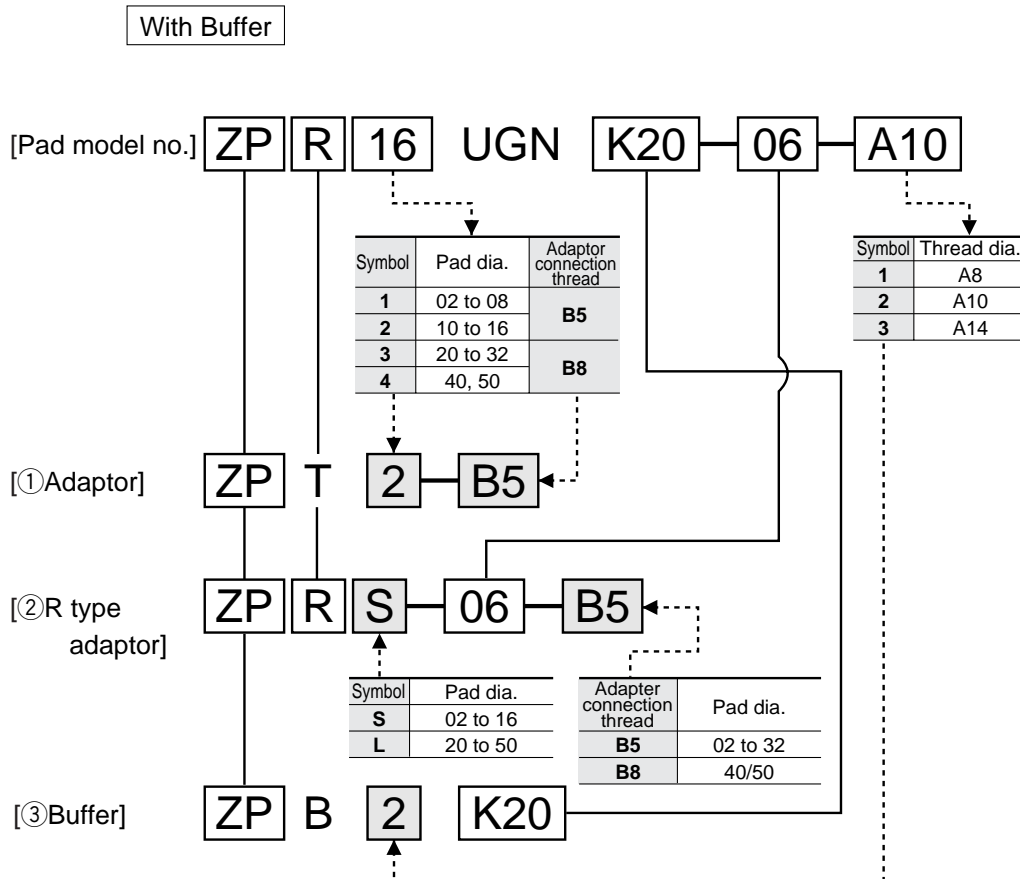
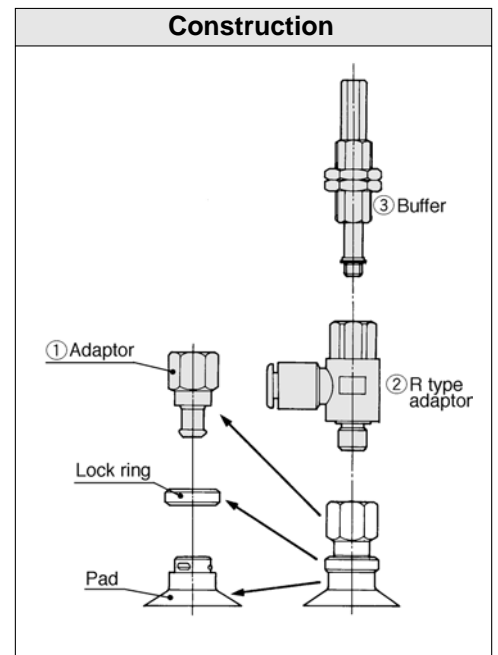
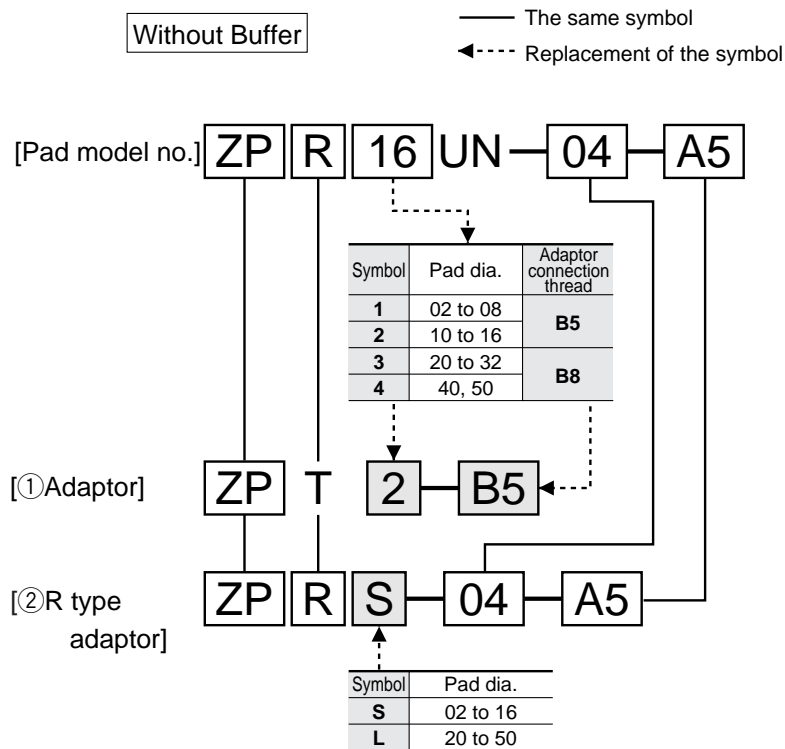

Replacement Parts: Adaptor/Buffer (Series ZPY)

Without Buffer

— The same symbol
 ←--- Replacement of the symbol

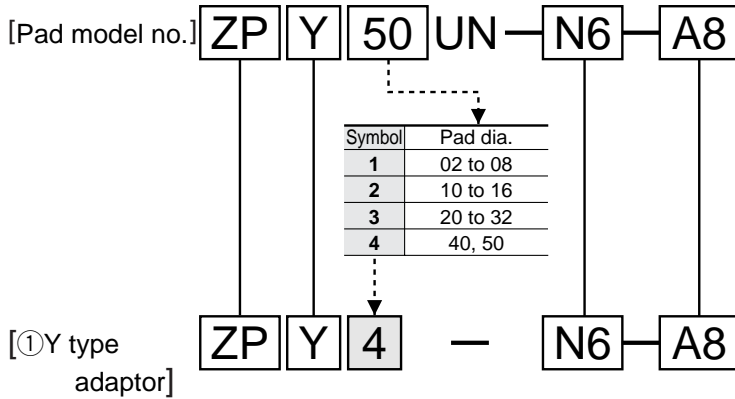

With Buffer

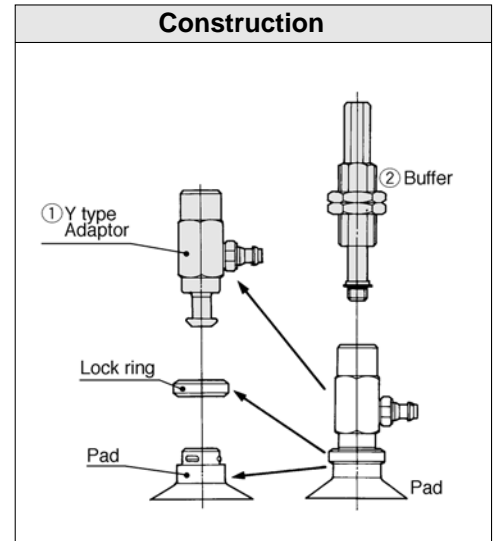
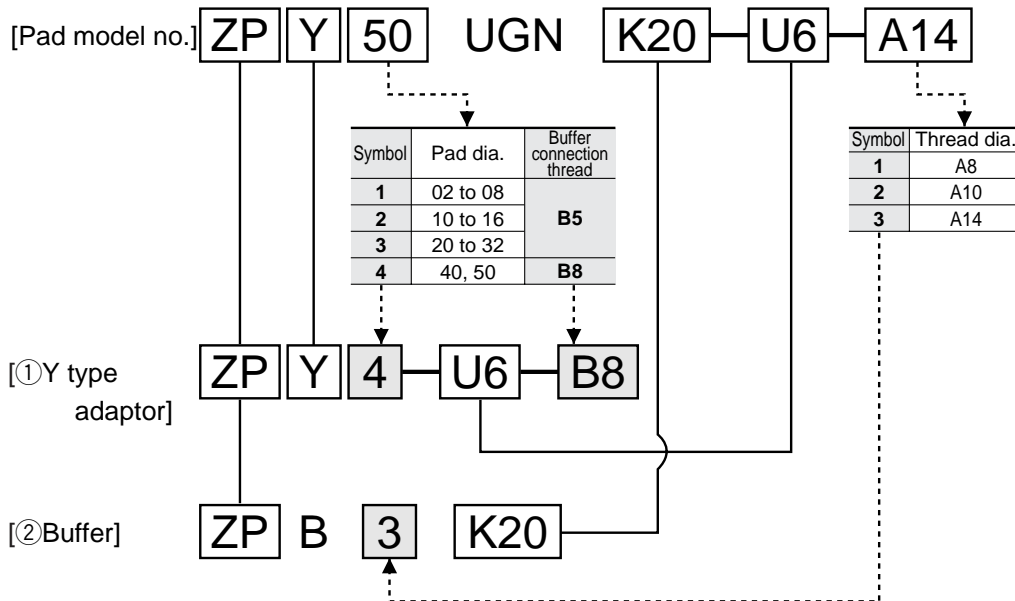

- ZX
- ZR
- ZM
- ZY
- ZH
- ZU
- ZL
- ZF
- ZP**
- ZCU
- CYV
- Vacuum related

Series ZP (Consult SMC for detailed specifications, dimensions and delivery.) Made to Order Specifications



1 Oval Pad/without Buffer

Non-standard oval pads without buffer for the ZPT, ZPR, and ZPY series.

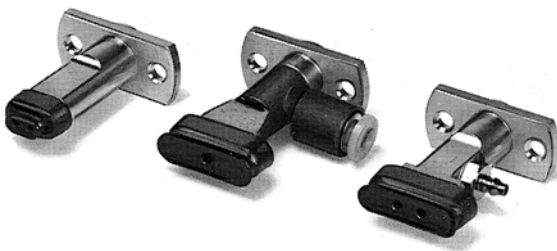

Specifications

Applicable model	ZPT/ZPR/ZPY (without buffer)		
Series	ZPT	ZPR	ZPY
Vacuum entry	Vertical	Lateral	Lateral
Direction	Vertical	Lateral	Lateral
Connection	Female thread	One-touch fitting	Barb fitting
Mounting connection	Two $\phi 3.5$ mounting holes are provided. Mount the pad with bolts at the desired position.		
Pad material	NBR, Silicon rubber, Urethane rubber, Fluorine rubber, Conductive NBR, Conductive silicon rubber		

Applicable pad diameter

Symbol	Short dia. X Long dia. (mm)	Symbol	Short dia. X Long dia. (mm)
3507	3.5 X 7	5030	5 X 30
4010	4 X 10	6010	6 X 10
4020	4 X 20	6020	6 X 20
4030	4 X 30	6030	6 X 30
5010	5 X 10	8020	8 X 20
5020	5 X 20	8030	8 X 30

Dimensions

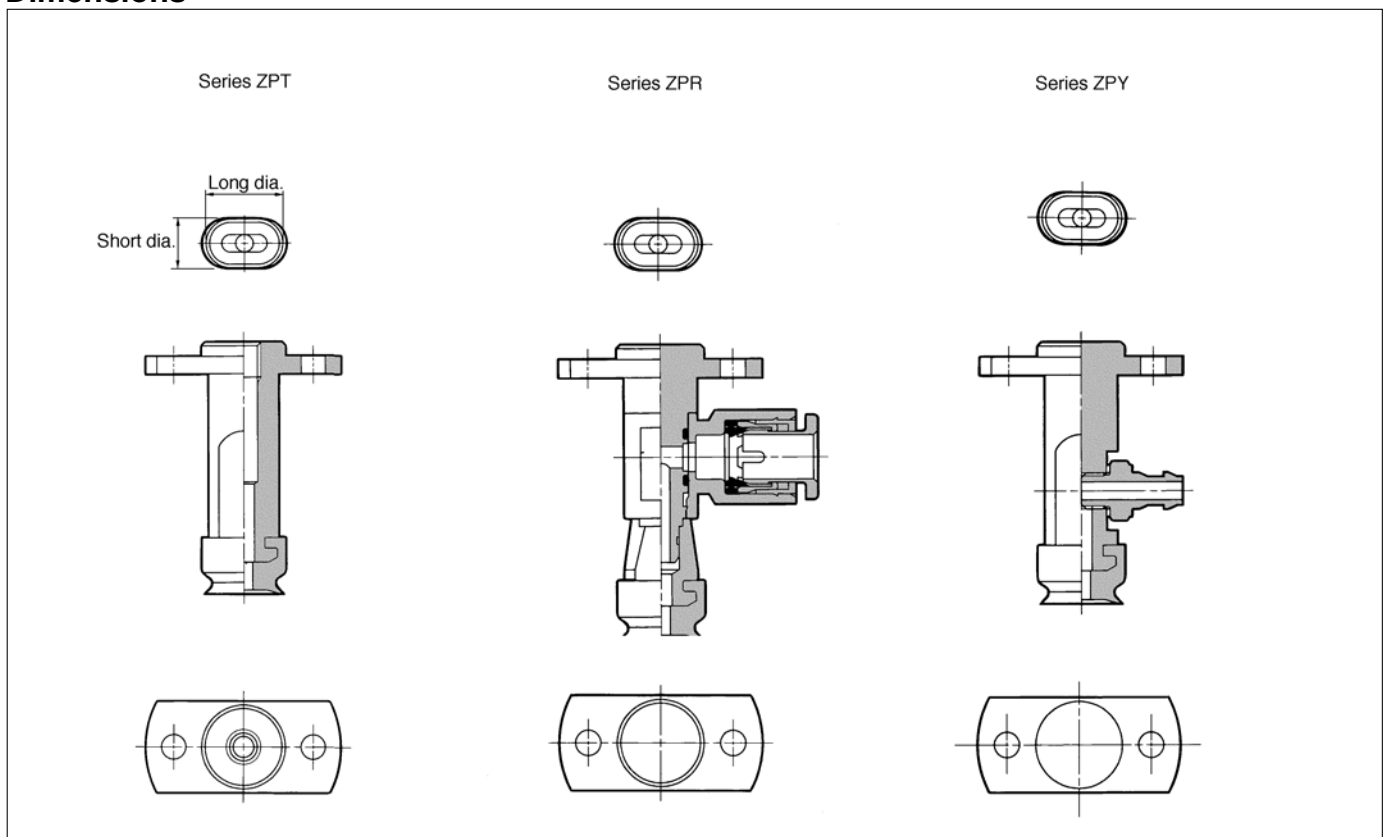

Series ZP (Consult SMC for detailed specifications, dimensions and delivery.)

Made to Order Specifications



2 Oval Pad/with Buffer

Non-standard oval pads with buffer for the ZPT, ZPR, and ZPY series.



Suitable for picking oblong loads in a space saving application.

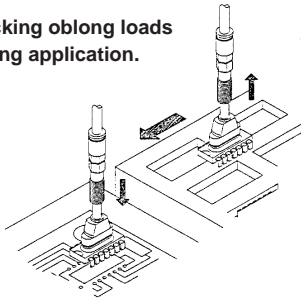

Specifications

Applicable model		ZPT/ZPR/ZPY (without buffer)		
Series		ZPT	ZPR	ZPY
Direction		Vertical	Lateral	Lateral
Vacuum entry	Connection	Female thread Barb fitting One-touch fitting	One-touch fitting	Barb fitting
	Mounting connection	Male thread	Male thread	Male/Female thread
Buffer style		Non-rotating (K)		
Pad material		NBR, Silicon rubber, Urethane rubber, Fluorine rubber, Conductive NBR, Conductive silicon rubber		

*Consult SMC for applicable strokes.

Applicable pad diameter

Symbol	Short dia. X Long dia. (mm)	Symbol	Short dia. X Long dia. (mm)
3507	3.5 X 7	5030	5 X 30
4010	4 X 10	6010	6 X 10
4020	4 X 20	6020	6 X 20
4030	4 X 30	6030	6 X 30
5010	5 X 10	8020	8 X 20
5020	5 X 20	8030	8 X 30

Dimensions

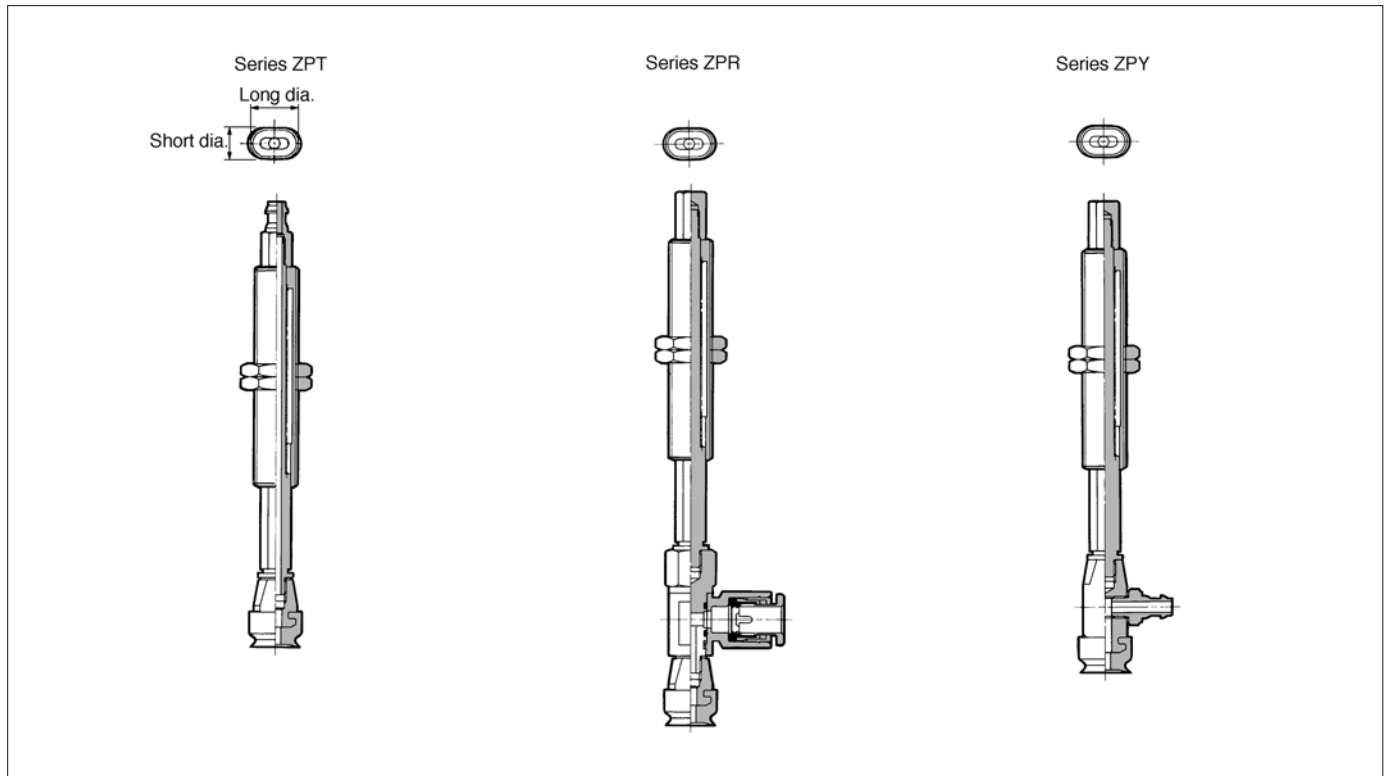

- ZX
- ZR
- ZM
- ZY
- ZH
- ZU
- ZL
- ZF
- ZP
- ZCU
- CYV
- Vacuum related

Series ZP (Consult SMC for detailed specifications, dimensions and delivery.)

Made to Order Specifications



③ Ball-joint Pad/without Buffer

Ideal for picking loads with a sloped surface.

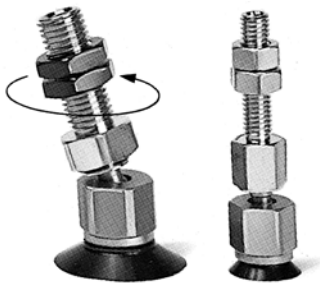

Specifications

Applicable model	ZPT/ZPR/ZPY (without buffer)		
Tilt angle	±15°		
Series	ZPT	ZPR	ZPY
Direction	Vertical	Lateral	Lateral
Vacuum entry	Male thread Female thread Barb fitting One-touch fitting	One-touch fitting	Barb fitting
Mounting connection	Common to the vacuum entry	Male thread/ Female thread	Male thread/ Female thread
Applicable pad shape	Flat style (U) only		
Pad material	NBR, Silicon rubber, Urethane rubber, Fluorine rubber, Conductive NBR, Conductive silicon rubber		
Applicable pad dia.	ø10, ø13, ø16, ø20, ø25, ø32, ø40, ø50		

Dimensions

Male thread

Series ZPT

Series ZPR

Series ZPY

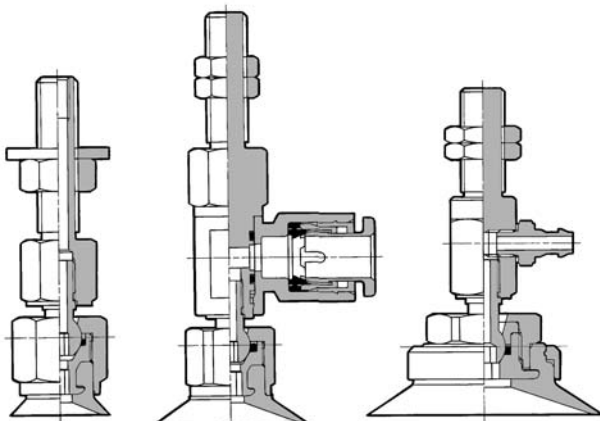

Female thread

Series ZPT

Series ZPR

Series ZPY

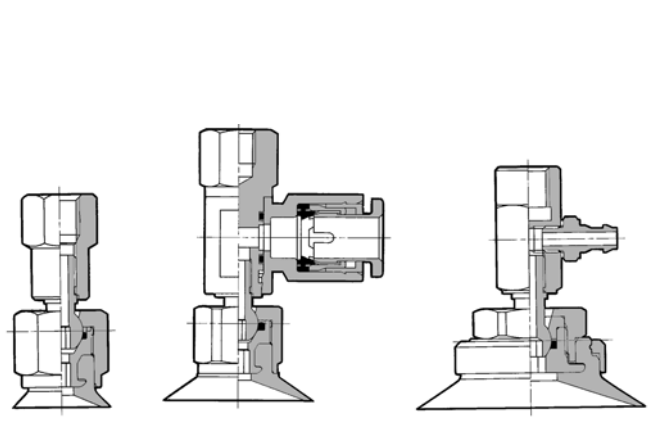

Series ZP (Consult SMC for detailed specifications, dimensions and delivery.)

Made to Order Specifications



4 Ball-joint Pad/with Buffer

Ideal for picking loads with a sloped surface.



Specifications

Applicable model		ZPT/ZPR/ZPY (with buffer)		
Tilt angle		±15°		
Series		ZPT	ZPR	ZPY
Direction		Vertical	Lateral	Lateral
Vacuum entry	Connection	Female thread One-touch fitting Barb fitting	One-touch fitting	Barb fitting
	Mounting connection	Male thread	Male thread	Male thread
Buffer style		Rotating (J), Non-rotating (K)		
Applicable pad shape		Flat style (U) only		
Pad material		NBR, Silicon rubber, Urethane rubber, Fluorine rubber, Conductive NBR, Conductive silicon rubber		
Applicable pad dia.		ø10, ø13, ø16, ø20, ø25, ø32, ø40, ø50		

*Consult SMC for applicable strokes.

Dimensions

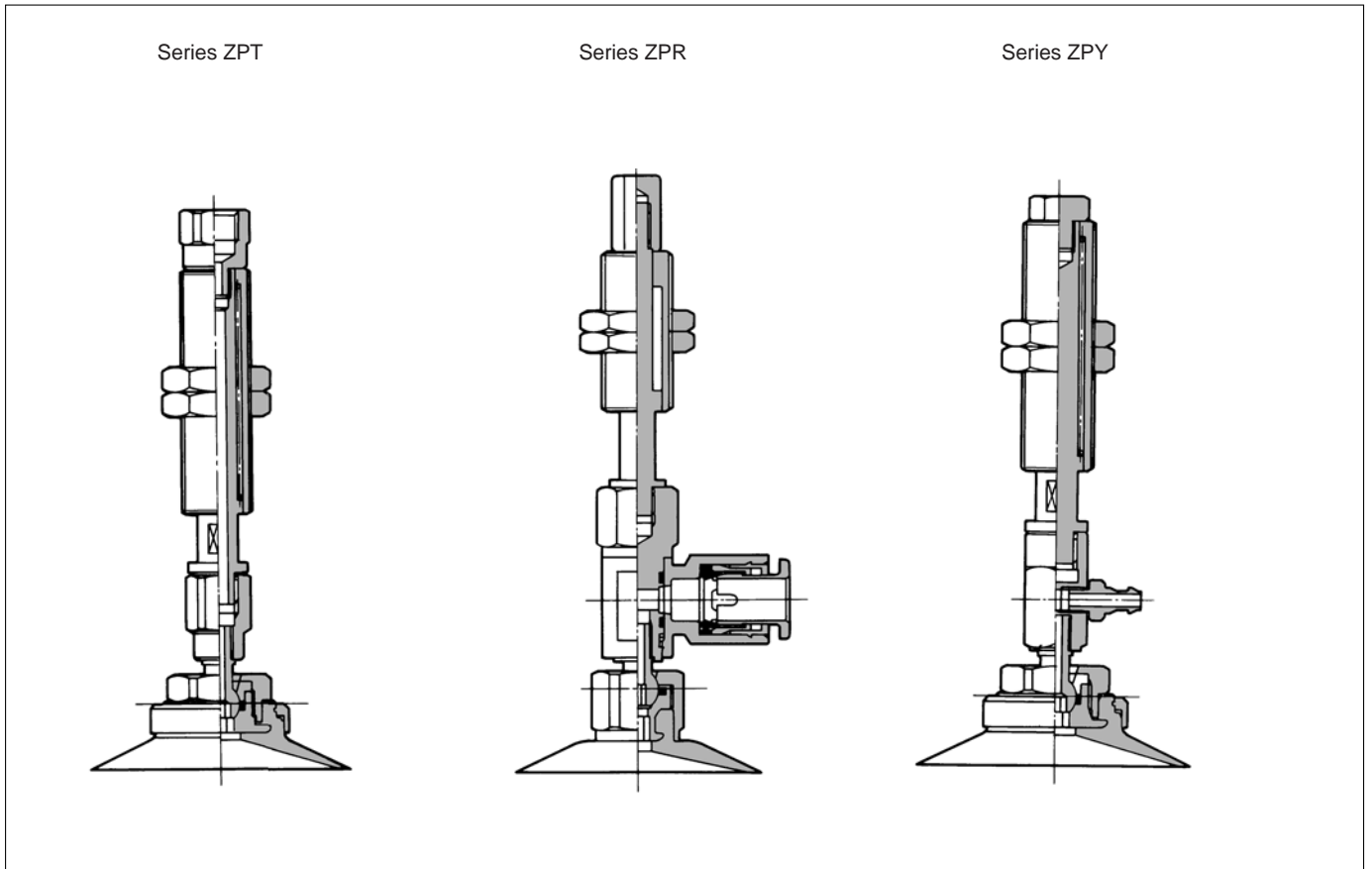

- ZX
- ZR
- ZM
- ZY
- ZH
- ZU
- ZL
- ZF
- ZP
- ZCU
- CYV
- Vacuum related



Made to Order Specifications

⑤ Heavy Duty Vacuum Pad/without Buffer

Pad for heavy duty material handling (ø150 to ø250).



Specifications

Applicable model	ZPT/ZPX (without buffer)	
Series	ZPT	ZPX
Pad diameter	ø150, ø200, ø250	ø150, ø200, ø250
Vacuum Direction	Vertical	Lateral
entry Connection	Female thread	Female thread
Applicable pad shape	Flat with ribs (H) only	
Mounting connection	Male thread/Female thread	Male thread/Female thread
Pad material	NBR, Silicon rubber, Urethane rubber, Fluorine rubber, Ethylene-propylene rubber	

Mounting thread

Series	Connection	Pad dia. (mm)	
		ø150/ø200	ø250
ZPT	Male thread	●	●
	Female thread	●	●
ZPX	Female thread	●	●

*Ball-joint type can be manufactured.

Dimensions

Series ZPT

Series ZPX

*Vacuum entry: Rc(PT)1/8 only



⑥ Vacuum Pad for Heavy Duty Material Handling/with Buffer

Pad for heavy duty material handling (ø150 to ø250)



Specifications

Applicable model	ZPT/ZPX (with buffer)		
Series	ZPT		ZPX
Pad diameter	ø150, ø200, ø250		
Vacuum entry	Direction	Vertical	Lateral
	Connection	Female thread	Female thread
Applicable pad shape	Flat with ribs (H) only		
Mounting connection	Male thread		
Buffer style	Rotating (J)		
Pad material	NBR, Silicon rubber, Urethane rubber, Fluorine rubber, Ethylene-propylene rubber		

*Consult SMC for applicable strokes.

ZX

ZR

ZM

ZY

ZH

ZU

ZL

ZF

ZP

ZCU

CYV

Vacuum related

Dimensions

