

# Vacuum Ejector

## Series ZM

### All in One!

- Built-in suction filter and silencer
- Air supply valve for generating a vacuum
- Vacuum release valve (equipped with a flow volume adjustment valve)
- Vacuum pressure switch (solid state or diaphragm style)

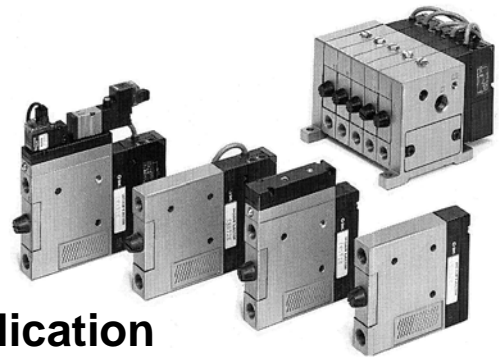

### Adaptable for manifold application

All tubing, wiring, indicators, and adjustment functions have been eliminated from the side surfaces, thus enabling assembly and maintenance while linked to a manifold.

- EXH system—common
- SUP system—common, individual

### Maximum air suction volume increased by 40% Maximum vacuum pressure – 84kPa

The suction volume has been increased by 40% through the adoption of a two-stage nozzle construction.

### Compact and lightweight

15.5mm width, 400g (full system)

### Air operated style

### Two-stage nozzle construction

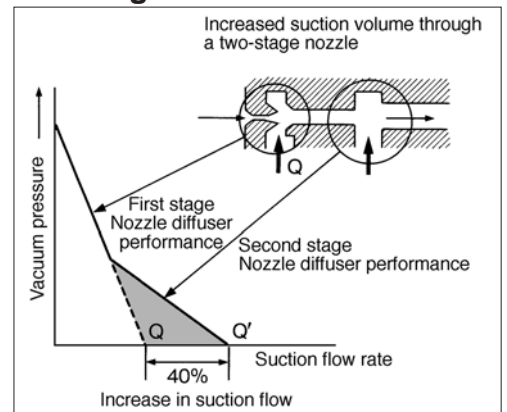

### Series ZM Applications

**Fields of application** Semi-conductor and electrical, automobile assembly, food and medical equipment, and various types of manufacturing and assembly equipment

**Machine types** Robotics for material handling, automatic assembly equipment, automatic transport equipment, pick-and-place, and printing equipment

**Functions** Vacuum picking and transport, vacuum picking and securing, and vacuum air flow

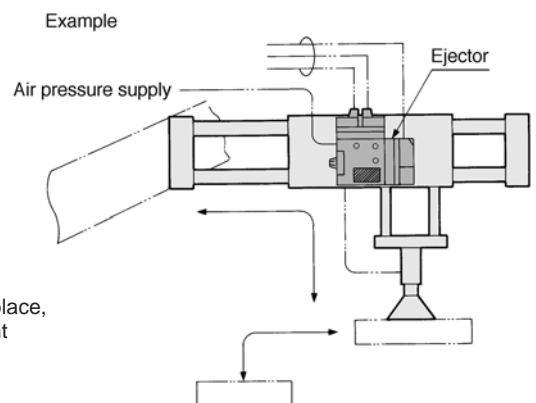

ZX

ZR

**ZM**

ZY

ZH

ZU

ZL

ZF

ZP

ZCU

Vacuum related

# Vacuum Ejector With Valve and Switch

## Series ZM

### How to Order

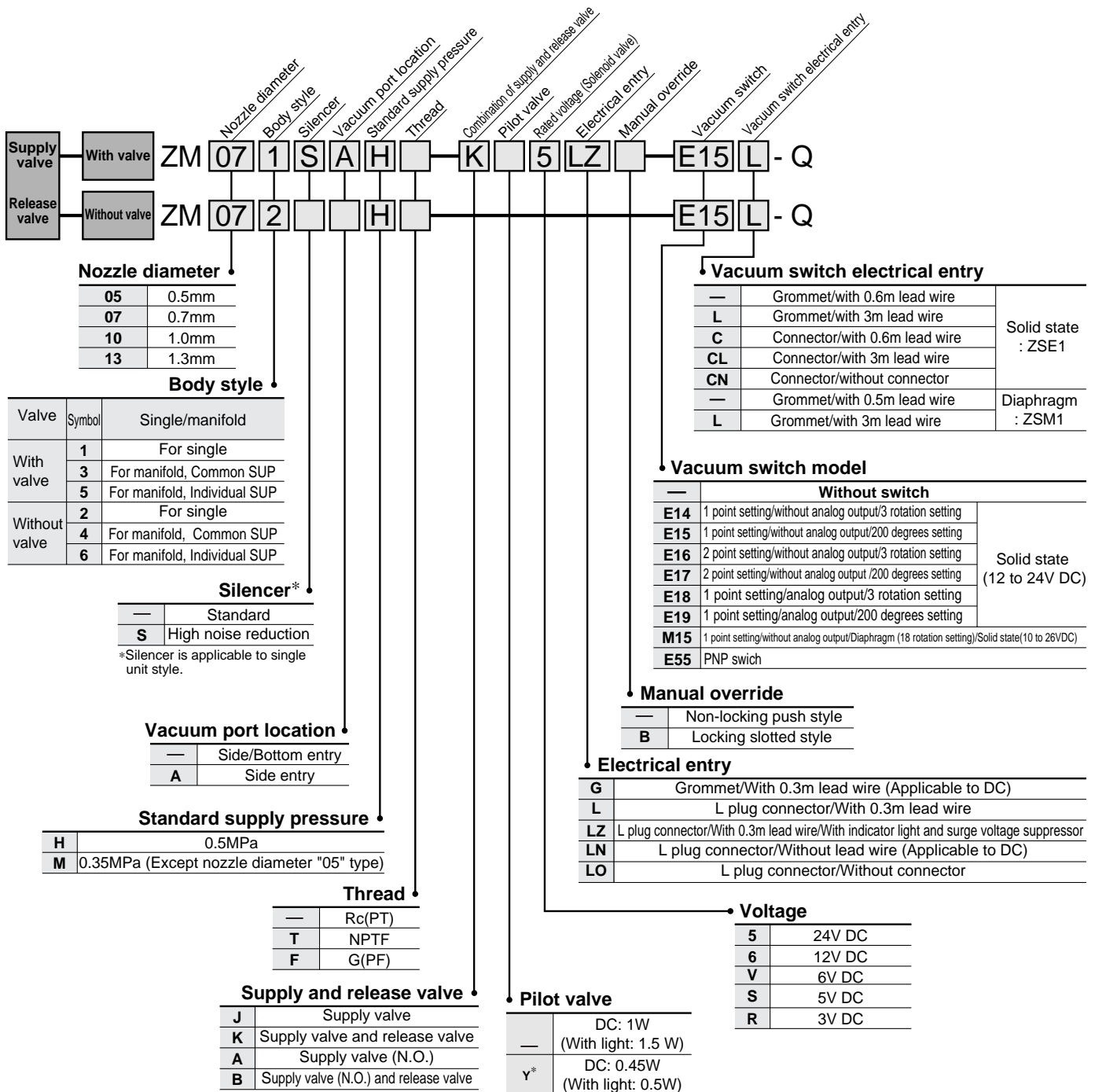

Refer to p.3.3-4 for air operated style.

\*24V DC and 12V DC are applicable to 0.45W type.

ZX
ZR
<b>ZM</b>
ZY
ZH
ZU
ZL
ZF
ZP
ZCU
Vacuum related

## Table ① How to Order Connector for Solid State Switch

- Without lead wire (A connector and 4 sockets) ..... **ZS - 20 - A**
- With lead wire ..... **ZS - 20 - 5A** 

Note) If ordering a switch with 5m lead wire, indicate the switch without connector and lead wire with connector.

Ex.) ZM   -E15CN.....1 pc.  
 ZS-20-5A-50 ..... 1 pc.



Lead wire length	
—	0.6m
<b>30</b>	3m
<b>50</b>	5m

## Table ② How to Order Connector for Supply Valve and Vacuum Release Valve

**VJ10 - 20 - 4A**  (DC)

Lead wire length	
—	300mm
<b>6</b>	600mm
<b>10</b>	1000mm
<b>15</b>	1500mm
<b>20</b>	2000mm
<b>25</b>	2500mm
<b>30</b>	3000mm

Note) If ordering a valve with 600mm or longer lead wire, indicate the valve without connector and connector ass'y.

〈Ex.〉 Lead wire length: 1000mm  
 ZM   -K1LO.....1 pc.  
 \*VJ10-20-4A-10.....2 pcs.

## How to Order

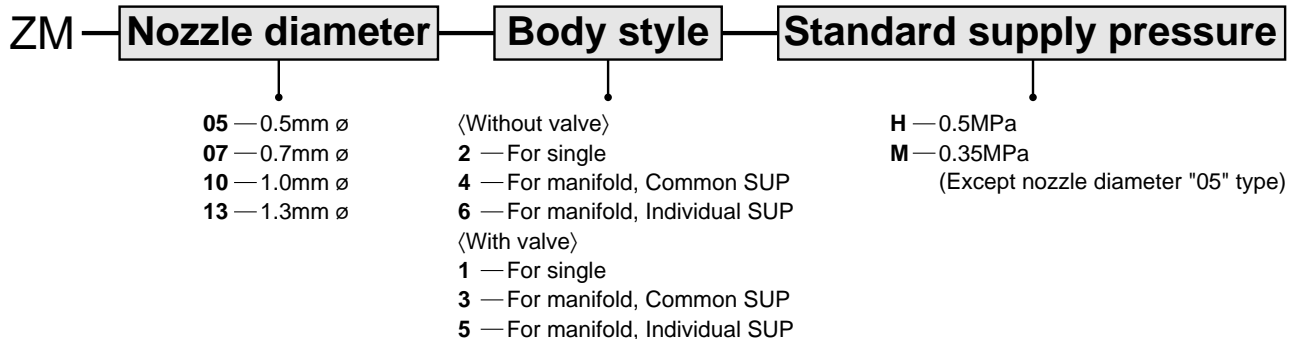

## Quick Delivery/Model

〈Without valve/Single unit〉	〈With valve/Single unit〉
• ZM052H	• ZM051H-K5LZ
• ZM072H	• ZM051H-K5LZ-E15
• ZM102H	• ZM071H-K5LZ
• ZM132H	• ZM071H-K5LZ-E15
	• ZM101H-K5LZ
	• ZM101H-K5LZ-E15
	• ZM131H-K5LZ
	• ZM131H-K5LZ-E15
	• ZM131M-K5LZ
	• ZM131M-K5LZ-E15

# Series ZM

## All in One!

- Built-in suction filter and silencer
- Air supply valve for generating a vacuum
- Vacuum release valve (equipped with a flow volume adjustment valve)
- Vacuum pressure switch (solid state, diaphragm)

## Adaptable for a manifold application

All tubing, wiring, indicators, and adjustment functions have been eliminated from the side surface, thus enabling assembly and maintenance while linked in a manifold.

- EXH system — common
- SUP system — common, individual

## Maximum air suction volume increased by 40% Maximum vacuum pressure — 84kPa

The suction volume has been increased by 40% through the adoption of a two-stage nozzle construction.

## Compact and lightweight 15.5mm width, 400g (full system)

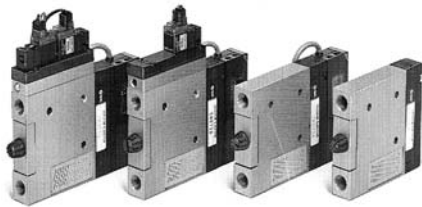

### Symbol

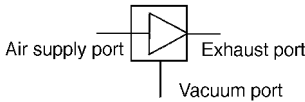

## Model

Nozzle dia. (mm)	Model	Standard supply pressure		Max. suction flow (ℓ/min)	Air consumption (ℓ/min)
		H	M		
0.5	ZM05□H	0.5MPa	—	18	12
0.7	ZM07□H			24	23
1.0	ZM10□H			36	46
1.3	ZM13□H			40	95
0.7	ZM07□M	—	0.35MPa	20	16
1.0	ZM10□M			26	32
1.3	ZM13□M			36	70

## Vacuum Ejector Specifications

Fluid	Air	
Max. operating pressure	0.7MPa	
Max. vacuum pressure	-84kPa	
Supply pressure range	Without valve	0.2 to 0.55MPa
	With valve	0.25 to 0.55MPa
Operating temperature range	Without valve	5 to 60°C
	With valve	5 to 50°C
Air supply valve	Main valve — Poppet	
Vacuum release valve	Pilot valve — VJ114, VJ324M	
Vacuum pressure switch	Solid state:	ZSE1-00-□□
	Diaphragm:	ZSM1-0□□
Suction filter	30μm-PE (Polyethylene)	

## Valve Specifications

Operation	Pilot operated
Main valve	NBR poppet
Effective area	3 mm <sup>2</sup>
Flow Qn (Nl/min)	163.3
Operating pressure	0.25 to 0.7MPa
Electrical entry	Plug connector, Grommet (available on DC)
Max. operating frequency	5Hz
Voltage	24/12/6/5/3V DC
Power consumption	DC: 1W(with light: 1.2W), AC100V: 1.4W(1.45W), AC110V: 1.45W(1.5W)

## Air Operated Valve Specifications

Refer to p.3.3-11 for dimensions.

## Ejector System Circuit

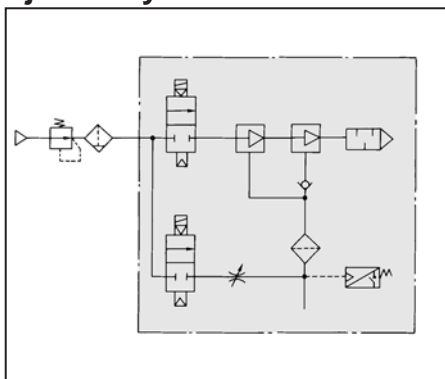

**Order Made** P. 3.3-17 to 3.3-19



## Specifications

Applicable nozzle size (mm)	ø0.5, ø0.7, ø1.0, ø1.3
Components	P Supply valve
	Q Supply valve and release valve
Port size	M3 X 0.5 M5 X 0.8
Main valve	N.C.

ZM05<sup>1</sup><sub>5</sub>3H-Q□

Nozzle diameter	
05	0.5mm
07	0.7mm
10	1.0mm
13	1.3mm

Port size	
3	M3 X 0.5
5	M5 X 0.8

Supply pressure	
H	0.5MPa
M*	0.35MPa

\*Except nozzle diameter "05" type

Air-operated valve	
P	Supply valve
Q	Supply valve, release valve



Note) Switch mounted style is also available.

## Construction/ZM□1□-K□L-E

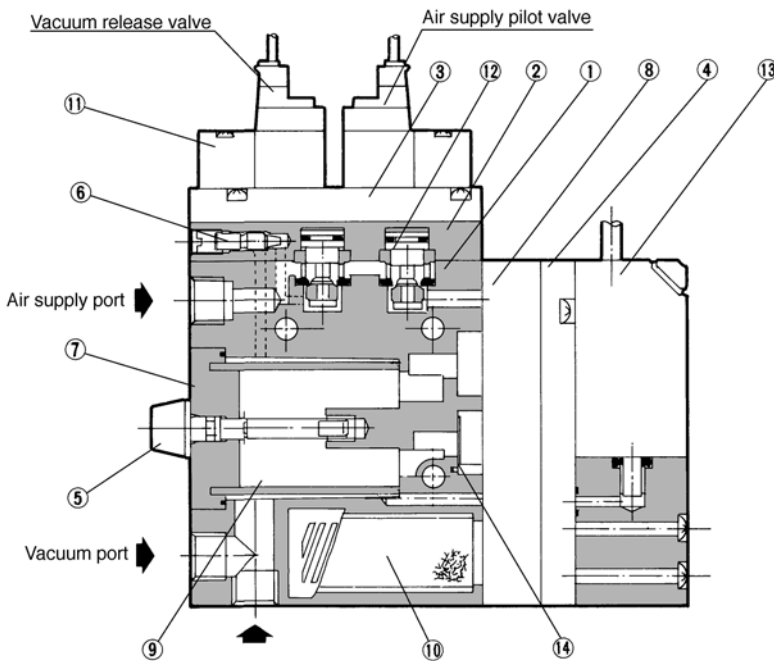

### ⚠ Precautions

Be sure to read before handling. Refer to p.0-20 and 0-21 for Safety Instructions and common precautions on the products mentioned in this catalogue, and refer to p.3.0-2 for precautions on every series.

### ⚠ Caution

**Operation of an ejector equipped with a valve:**

When the air supply pilot valve is turned ON, air flows to the diffuser assembly, and a vacuum is created.

When the pilot valve for releasing the vacuum is turned ON, air flows to the vacuum port side, immediately causing a release in the vacuum. The release speed can be adjusted by regulating the flow volume adjustment screw.

**When the supply valve is turned OFF,** the atmospheric pressure causes the air to flow back from the silencer, thus releasing the vacuum. However, in order to properly release a vacuum, a vacuum release valve must be used.

**Operating environment:**

Because the filter cover is made of polycarbonate, do not use it with or expose it to following chemicals: paint thinner, carbon tetrachloride, chloroform, acetic ester, aniline, cyclohexane, trichloroethylene, sulfuric acid, lactic acid, water-soluble cutting oil (alkalinic), etc. Also, do not expose it to direct sunlight.

**Matching of the ejector to the vacuum circuit:**

For precautions associated with matching of the ejector to the vacuum circuit, refer to the technical data in "Best Pneumatics 3".

## Component Parts

No.	Description	Material	Notes
①	Body	Aluminum die cast	
②	Valve cover	Zinc die cast	
③	Adapter plate	Zinc die cast	
④	Cover	Zinc die cast	Without switch: ZM-HCA, With switch: ZM-HCB
⑤	Tension bolt	Stainless steel/Polyacetal	
⑥	Release flow adjusting needle	Brass	Electroless nickel plated

## Replacement Parts

No.	Description	Material	Part No.
⑦	Filter cover ass'y	—	ZM-FCB-0
⑧	Diffuser ass'y	—	ZM□□□□-0
⑨	Suction filter	Polyethylene	ZM-SF
⑩	Silencer ass'y	—	ZM-SA
⑪	Pilot valve	—	VJ114-□□□□
⑫	Poppet valve ass'y	—	ZM-PV-0
⑬	Vacuum switch	—	ZSE1-00-□□ ZSM1-015 ZSM1-021
⑭	Check valve	NBR	ZM-CV

ZX

ZR

**ZM**

ZY

ZH

ZU

ZL

ZF

ZP

ZCU

Vacuum related

### ZM05□H

Exhaust characteristics

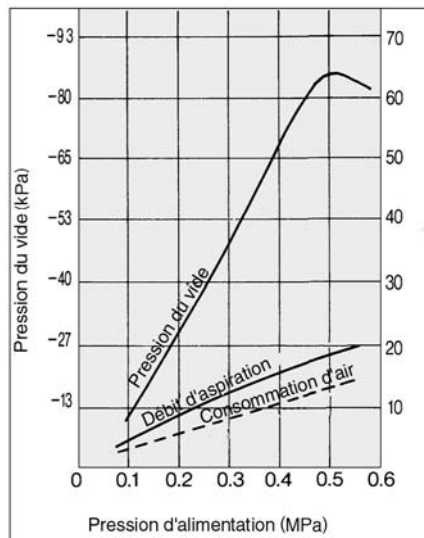

Flow characteristics

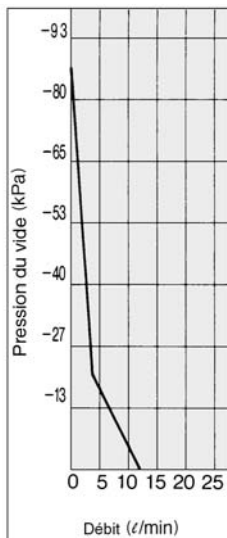

### ZM07□H

Exhaust characteristics

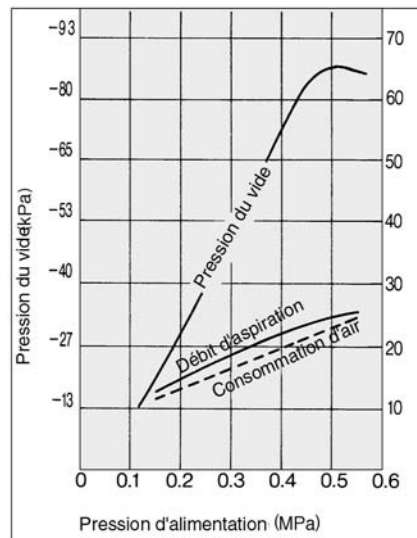

Flow characteristics

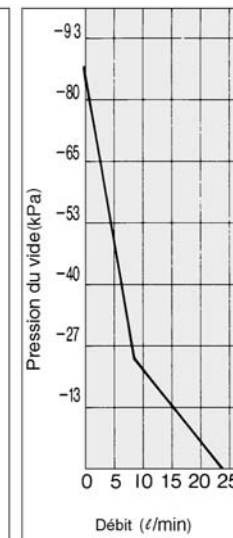

### ZM10□H

Exhaust characteristics

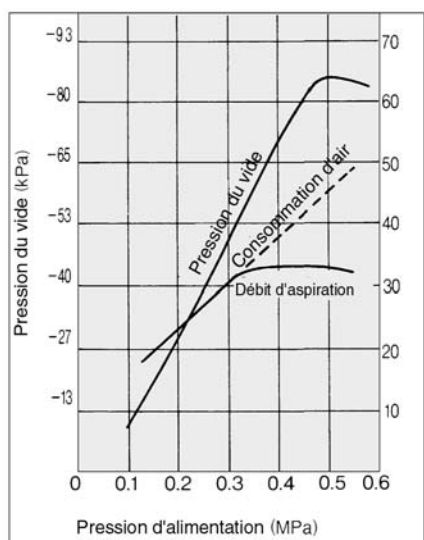

Flow characteristics

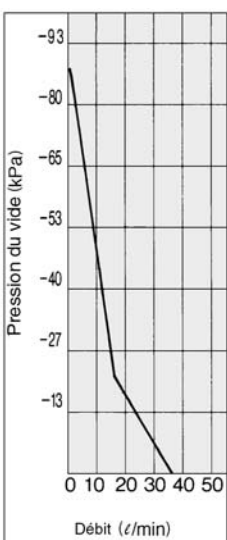

### ZM13□H

Exhaust characteristics

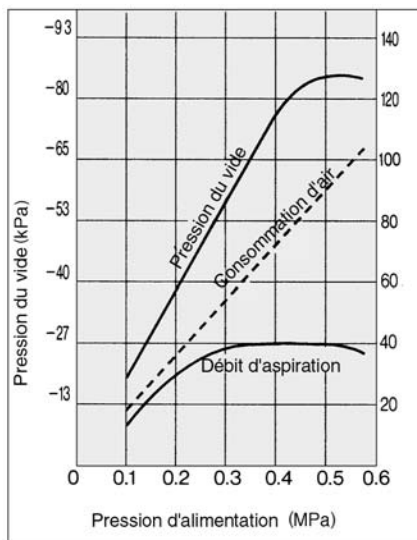

Flow characteristics

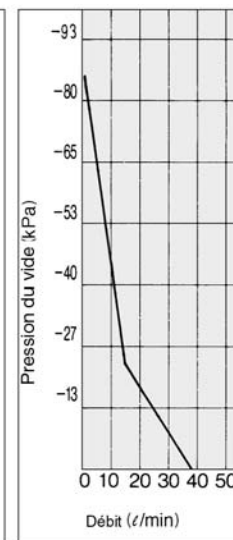

### ZM07□M

#### Exhaust characteristics

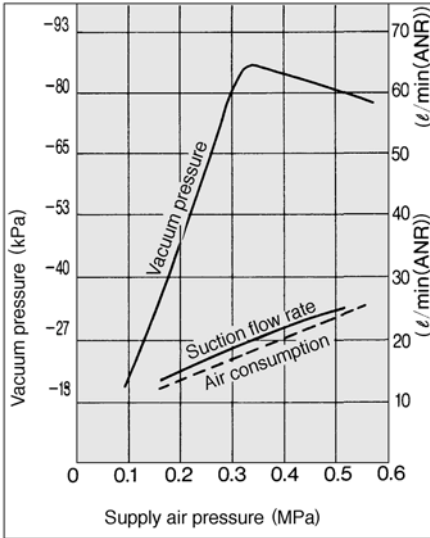

#### Flow characteristics

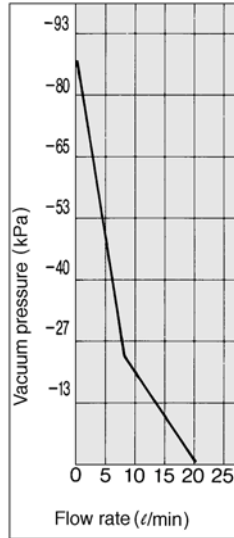

### ZM10□M

#### Exhaust characteristics

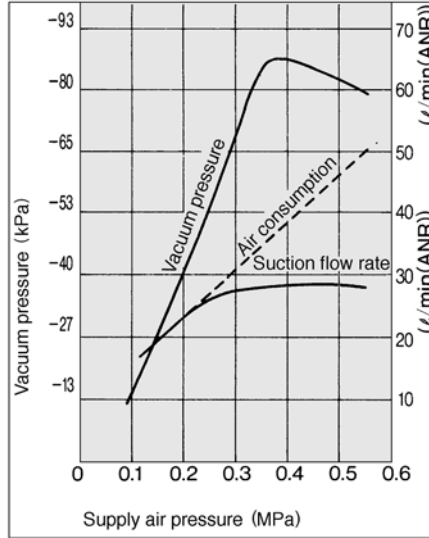

#### Flow characteristics

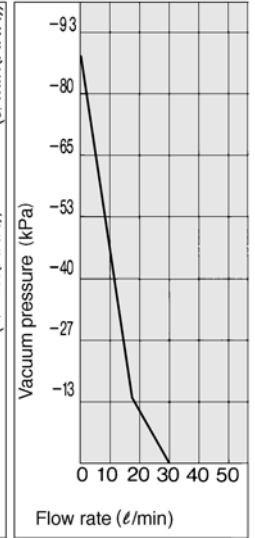

### ZM13□M

#### Exhaust characteristics

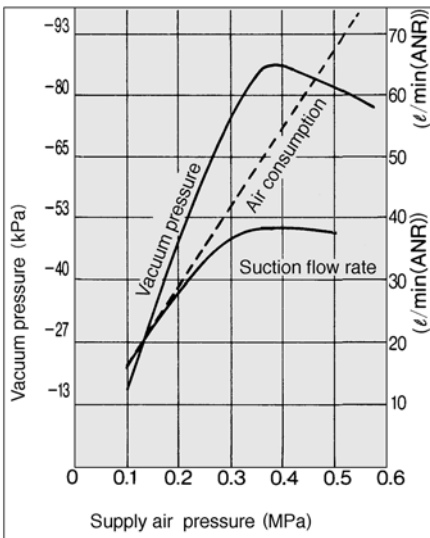

#### Flow characteristics

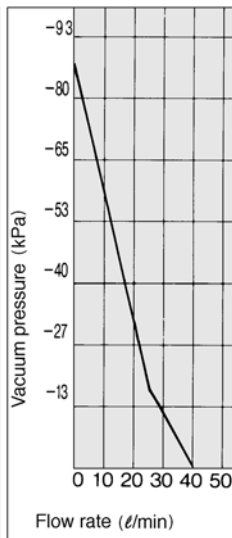

### How to Read the Graph

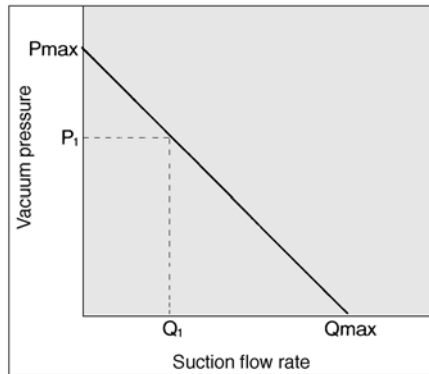

Flow characteristics are expressed in ejector vacuum pressure and suction flow. Fluctuations in the suction flow rate will change the vacuum pressure. Normally this relationship is expressed in ejector standard use. In graph, Pmax is according to catalogue use. Changes in vacuum pressure are expressed in the order below.

- 1) When ejector suction port is covered and made airtight, suction flow is 0 and vacuum pressure is at maximum value (Pmax).
  - 2) When suction port is opened gradually, air can flow through, (air leakage), suction flow increases, but vacuum pressure decreases. (condition P<sub>1</sub> and Q<sub>1</sub>)
  - 3) When suction port is opened further, suction flow moves to maximum value (Q max), but vacuum pressure is near 0. (atmospheric pressure).
- When vacuum port (vacuum piping) has no leakage, vacuum pressure becomes maximum, and vacuum pressure decreases as leakage increases. When leakage value is the same as max. suction flow, vacuum pressure is near 0.

In the case when ventirative or leaky work should be adsorbed, please note that vacuum pressure will not be high.

ZX

ZR

ZM

ZY

ZH

ZU

ZL

ZF

ZP

ZCU

Vacuum related

## Vacuum Pressure Switch/Solid State Switch (ZSE), Diaphragm Switch (ZSM)

### Vacuum Switch Specifications

Model	ZSE1-00-14	ZSE1-00-15	ZSE1-00-16	ZSE1-00-17	ZSE1-00-18	ZSE1-00-19	ZSM1-015	ZSM1-021
Sensor	Solid state						Diaphragm	
Switch	Electronic circuit						Solid state	Reed
Setting pressure range	0 to -101kPa						-26.6 to -79.8kPa	
Hysteresis	1 to 10% of the set pressure (Changeable)	3% full span or less (Fixed)		1 to 10% of the set pressure (Changeable)		17% full span	23% full span	
Repeatability	±1% full span or less							
Temperature characteristics	±3% full span or less						±5% full span	
Voltage	12 to 24V DC (Ripple ±10% or less)						10 to 26V DC	100V AC
ON-OFF output	Open collector 30V Max. 80mA						Open collector 30V, Max. 100mA	—
Setting point	1 point		2 points		1 point		1 point	
Indicator light	Lights ON		Lights ON (Output1: Red, Output2: Green)		Lights ON		Lights ON	
Setting trimmer	3 rotations	200 degrees	3 rotations	200 degrees	3 rotations	200 degrees	18 rotations	
Current consumption	17mA or less (24V DC, at ON state)		25mA or less (24V DC, at ON state)		17mA or less (24V DC, at ON state)		16mA	—
Max. current	—						—	5 to 20mA
Max. operating pressure	0.2MPa						0.5MPa	

\*When using ejector system, instantaneous pressure up to 0.5MPa will not damage the switch.

### Solid State Switch (ZSE)

#### Circuit/Connection

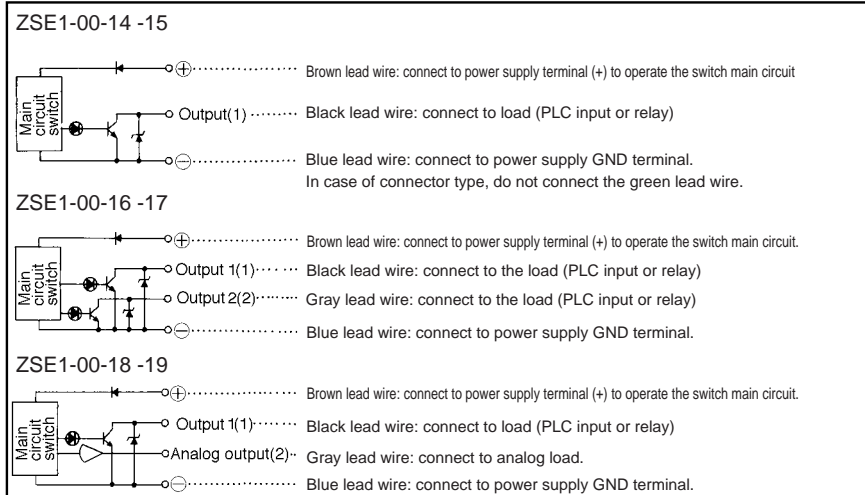

#### Connection with PLC

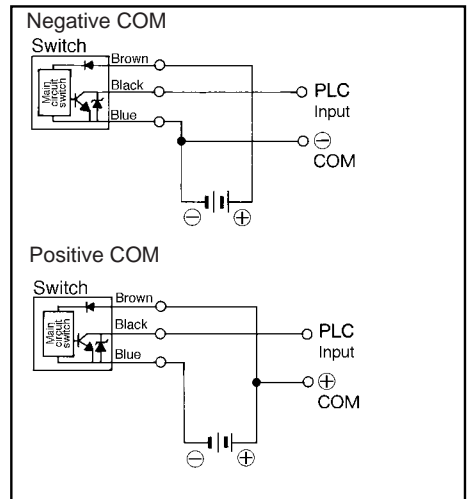

### Diaphragm Switch (ZSM)

#### <Solid state switch: ZSM1-015>

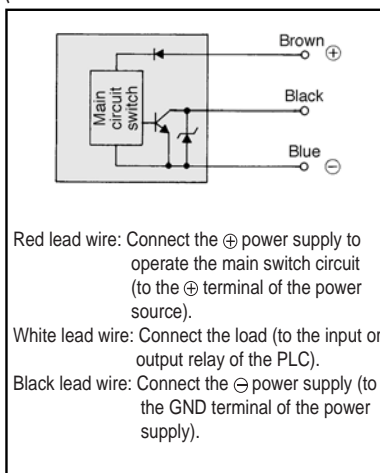

#### <Reed switch: ZSM1-021>

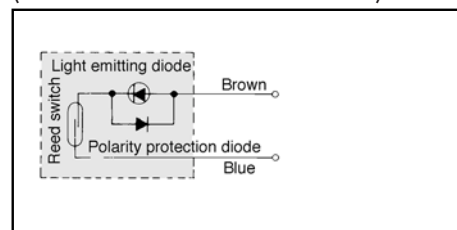

#### Contact protection box

The switch does not have a built-in contact protection circuit. Use this box if an induction load is applied or if the lead wire is longer than 5 meters.

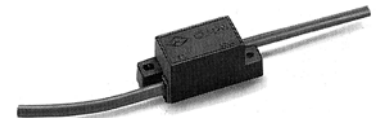

#### Internal circuit of contact protection box

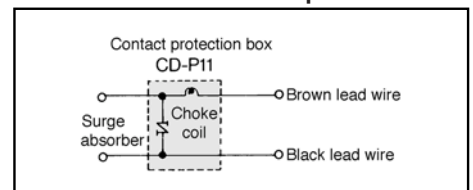



## Hysteresis

Hysteresis is the difference in pressure when the output signal is ON and OFF. The pressure to be set is the ON pressure.

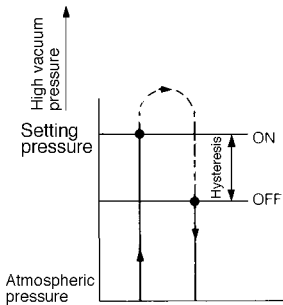

## Number of Rotations/Pressure Adjustment Screw

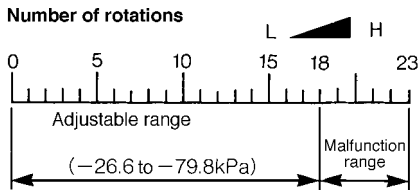

Set the pressure adjustment screw to be within 18 turns from its minimum setting.

## Silencer

A hole is provided in one side of the window of the silencer's exhaust port. Therefore, if the silencer is to be attached against a wall or a board, make sure that the window of the exhaust port is not covered by the wall or the board.

To reverse the position, apply your finger to the side without a hole to forcefully push and remove the silencer. Then, turn the silencer around and push it into place. At this time, make sure that the window of the silencer is located away from the diffuser.

## Mounting Direction of Silencer

Noise reduction		
Noise reduction impossible		

## How to Use Plug Connector

### ① Insertion/Removal of Connector

- Insertion: Push the connector straight on to the pins of the solenoid, making sure the lip of the lever securely "locks" into the groove of the solenoid cover.
- Removal: Press the lever against the connector housing and pull it outward from the solenoid.

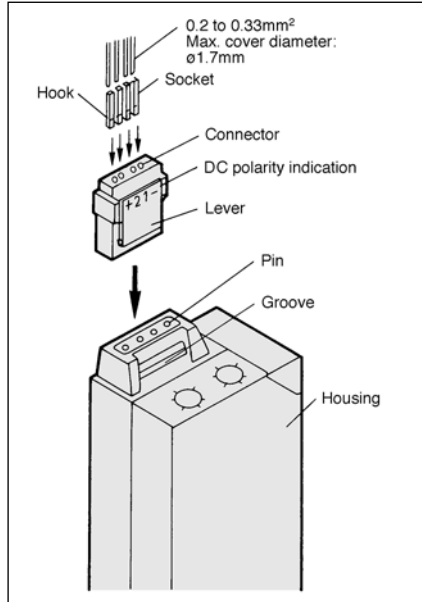

### ② Crimping connection of lead wire and socket

Strip 3.2 to 3.7mm of the lead wire ends, insert each stripped wire into a socket and crimp contact it using special crimping tool. Be careful that the outer insulation of the lead wires does not interfere with the socket contact part. (Crimping Tool: DXT170-75-1)

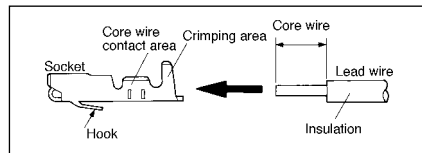

### ③ Connection/Disconnection of socket with lead wire

#### ● Connection

Insert lead wire and crimped socket into square holes (indicated as A, B, COM) of connector. Press the socket in fully until the hook of the socket locks into the groove of the connector housing. Confirm the locked position by lightly pulling on the lead wire.

#### ● Disconnection

To remove the socket from the connector, pull out lead wire while depressing the hook of the socket with a fine screw driver (or similar), if the socket is to be re-used, reposition the hook again.

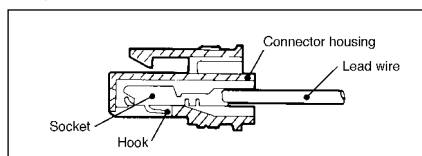

## ⚠ Precautions

Be sure to read before handling. Refer to p.0-20 and 0-21 for Safety Instructions and common precautions on the products mentioned in this catalogue, and refer to p.3.0-2 for precautions on every series.

### Mounting

#### ⚠ Warning

##### ① Do not drop or strike the switch.

When handling the switch, do not apply an excessive impact (1000 m/s<sup>2</sup>) by dropping or striking the switch. Even if the switch case itself does not become damaged, it could damage the internal switch and cause it to malfunction.

##### ② To handle the product, hold it by its body.

The tensile strength of the power supply cord is 49N (5kgf). If the cord is pulled with a greater force, it could lead to a malfunction. When handling the product, make sure to hold it by its body.

##### ③ Never move the switch assembly or loosen the switch assembly mounting screws.

### Wiring

#### ⚠ Warning

##### ① Do not repeatedly bend or pull the lead wires.

If the lead wires are routed in such a way that repetitive bending stress or tensile strength is applied, it could cause broken wires. If the lead wires become damaged, the product must be replaced (the lead wires cannot be replaced due to the grommet type wiring).

### Power Supply

#### ⚠ Warning

##### ① Vacuum pressure switch:

The performance is not affected even if an momentary pressure of approximately 0.5MPa is applied (during a vacuum break). However, make sure that a constant pressure that is higher than 0.2MPa is not applied.

### Operating Environment

#### ⚠ Warning

① It cannot be used in a magnetic region.

### In case of ZSM1-021

#### ⚠ Warning

● Operate the product within the specified operating amperage range. If the product is used below the specified operating amperage, the indicator light will not turn ON. If the product is used above the specified operating amperage, the indicator light will become damaged.

A parallel connection of the switches does not cause any problem. However, be careful with a series connection because the voltage drop will increase due to the internal resistance of the light-emitting diodes (approximately 2V per switch).

### In case of ZSM1-015

#### ⚠ Warning

● Make sure to connect the 3 lead wires correctly. If they are interchanged, they could lead to a malfunction or damage.

● Although an output signal is instantly emitted immediately after the power is turned ON, this is not a malfunction.

ZX

ZR

ZM

ZY

ZH

ZU

ZL

ZF

ZP

ZCU

Vacuum related

# Series ZM

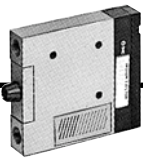

## Single/Without Valve Basic Style

ZM□2<sup>H</sup><sub>M</sub>

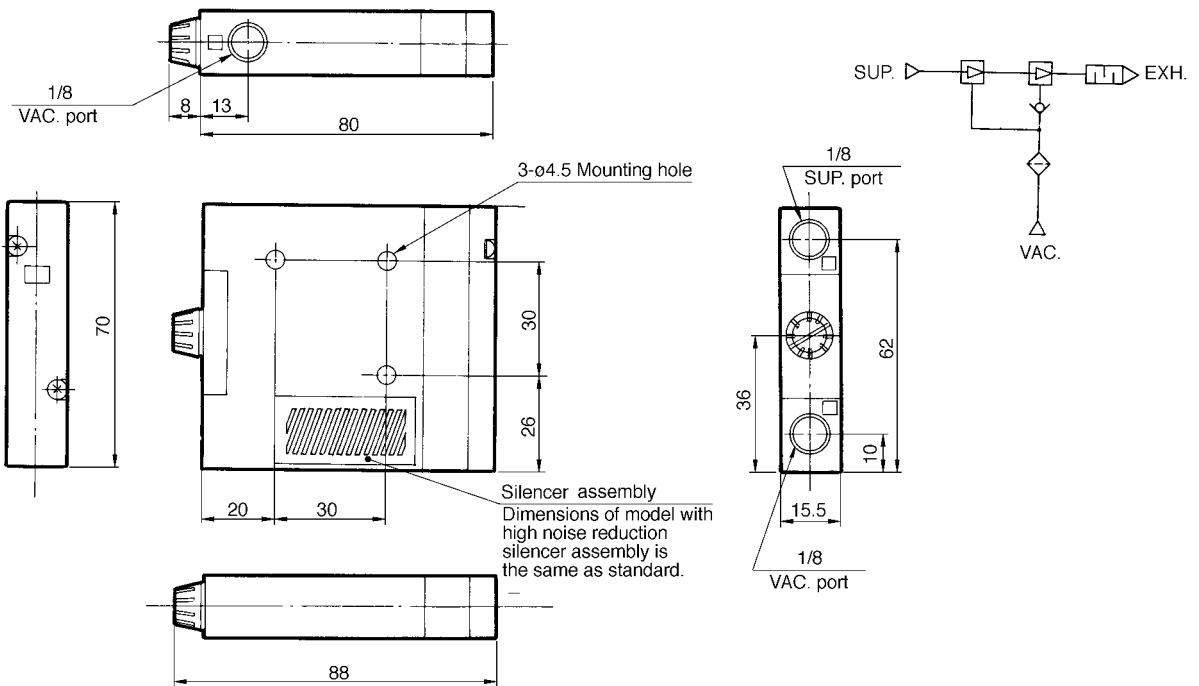

(Side entry style is equipped with plugs.)



## Single/Without Valve With Vacuum Switch

ZM□2<sup>H</sup><sub>M</sub>-□□

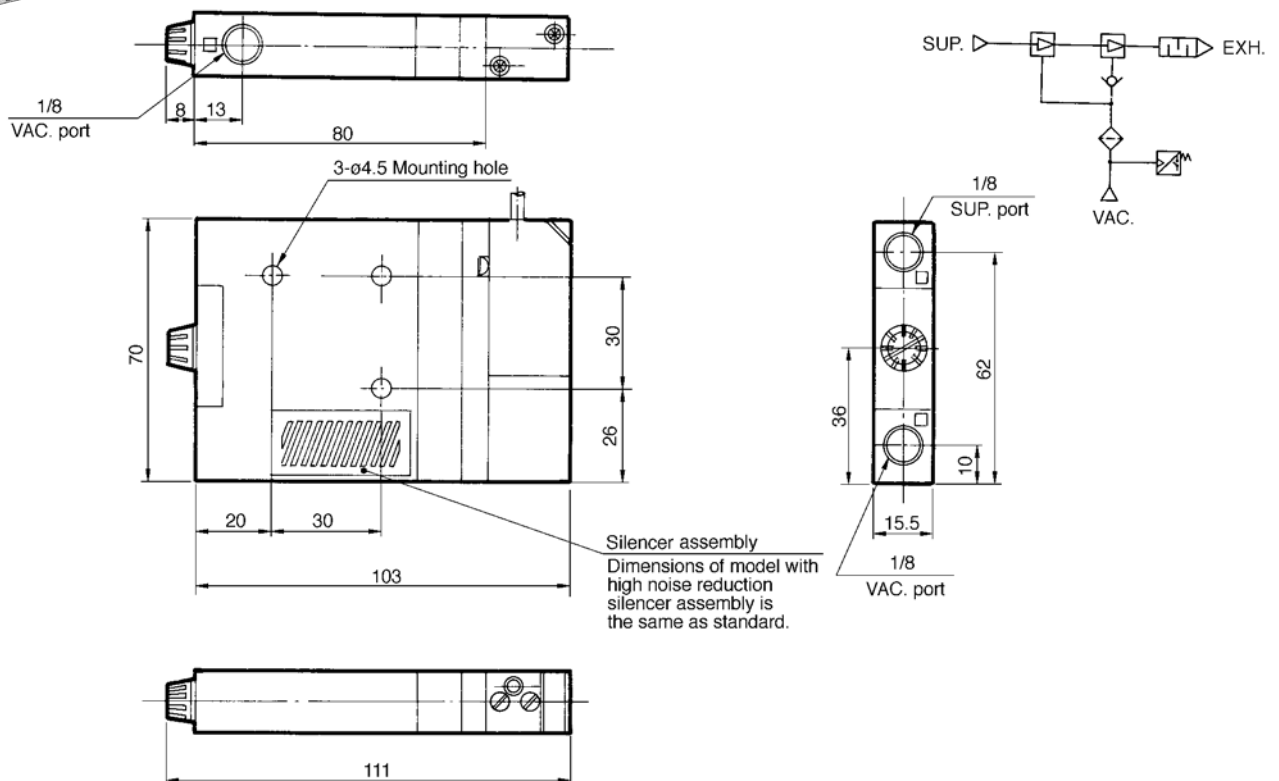

(Side entry style is equipped with plugs.)

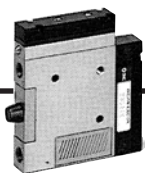

## Air operated Style

ZM□1<sup>H-Q</sup><sub>M-P</sub>□

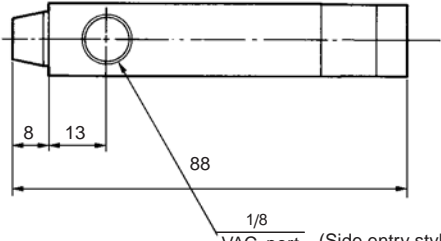

(Side entry style is equipped with plugs.)

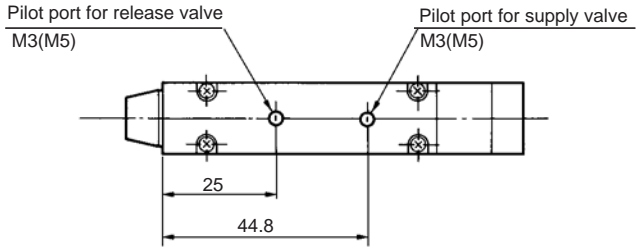
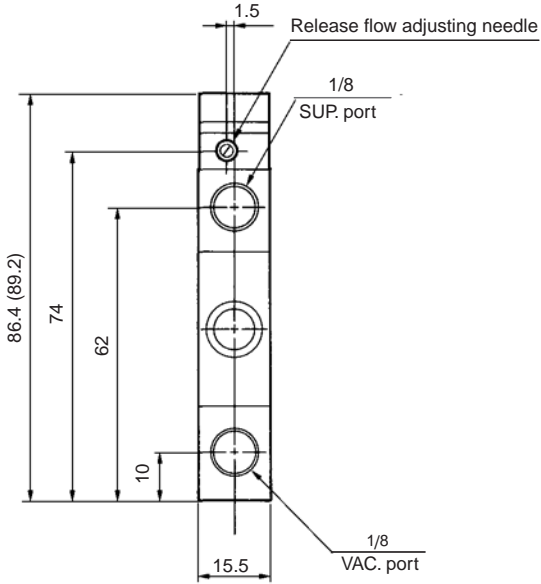
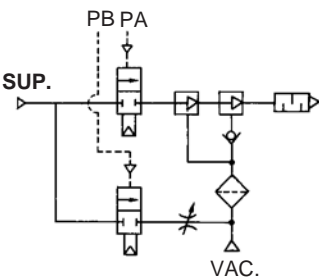
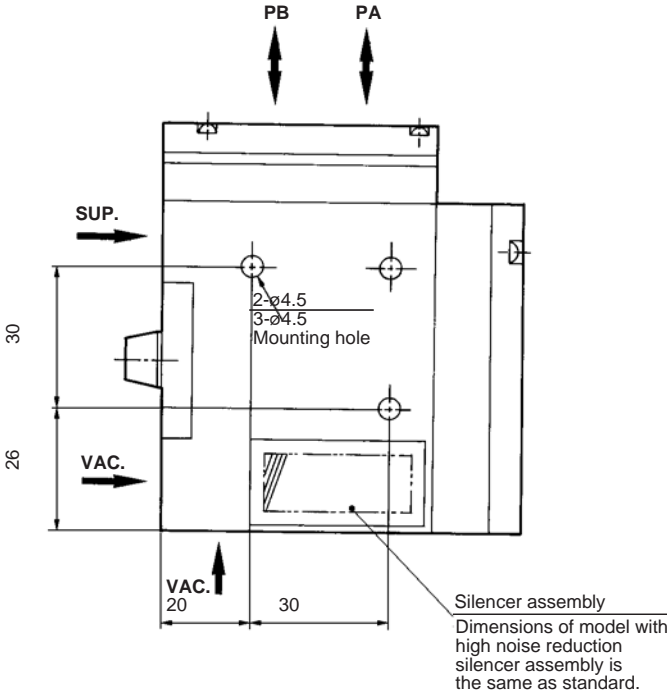

- ZX
- ZR
- ZM**
- ZY
- ZH
- ZU
- ZL
- ZF
- ZP
- ZCU
- Vacuum related

This dimension shows Q3 (M3 X 0.5). Dimension in parentheses shows Q5 (M5 X 0.8).

# Series ZM

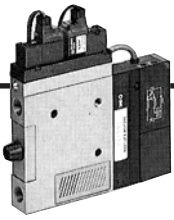

Single/With Valve

With Switch and Valve

ZM□1<sup>H</sup><sub>M</sub>-K□□□-E□

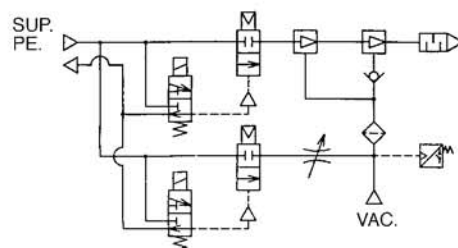
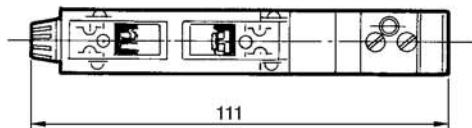
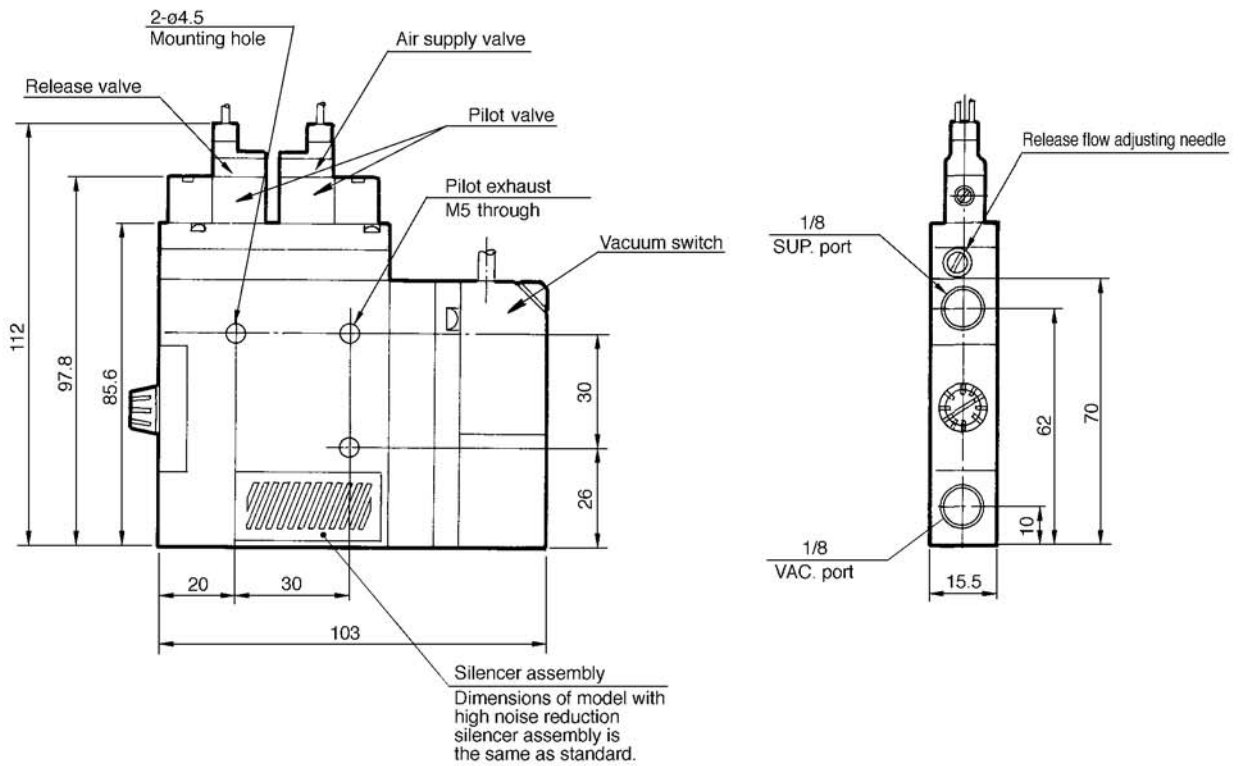
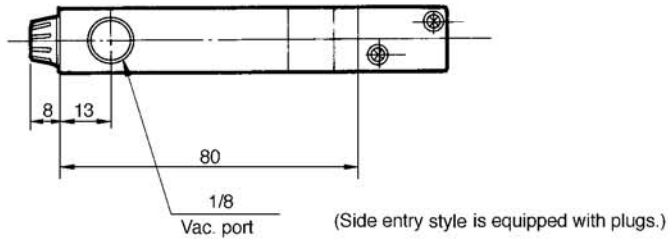

## Single/With air supply valve(N.O.) and vacuum release valve

ZM□1<sup>H</sup><sub>M</sub>-B□□

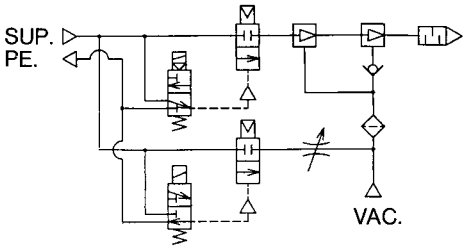
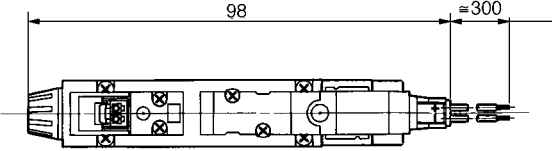
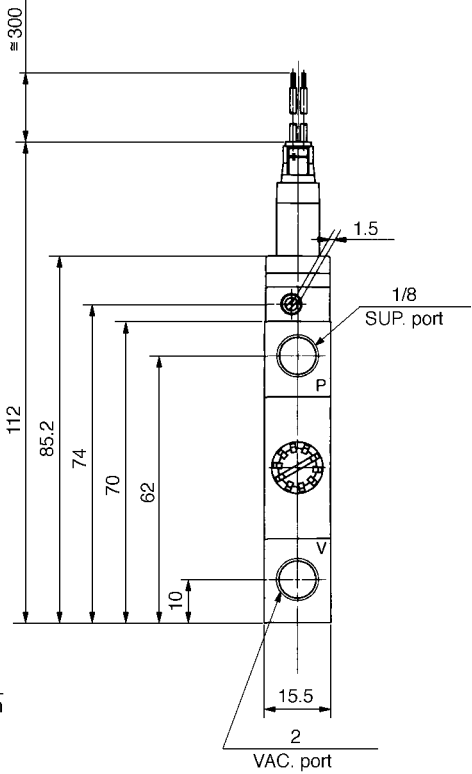
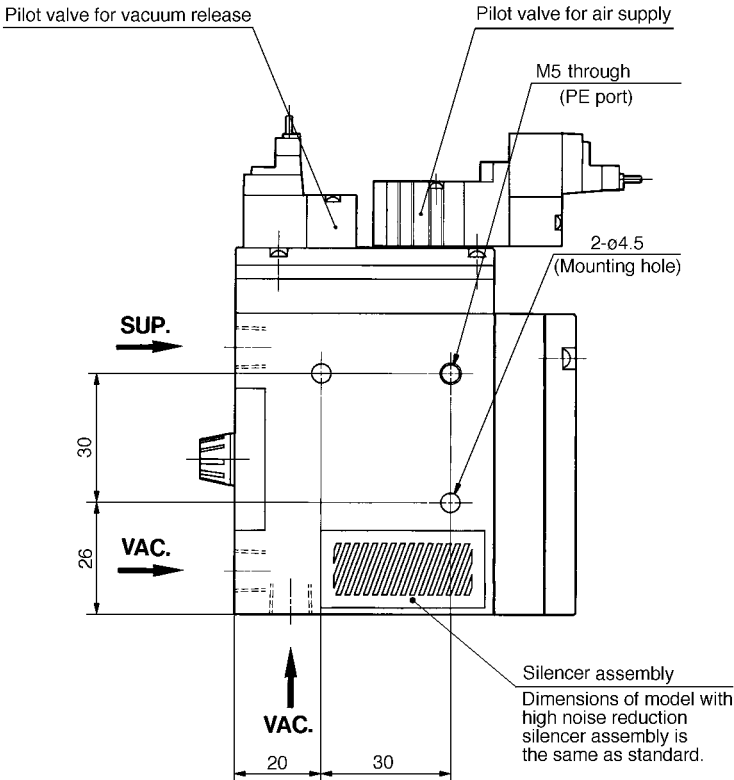
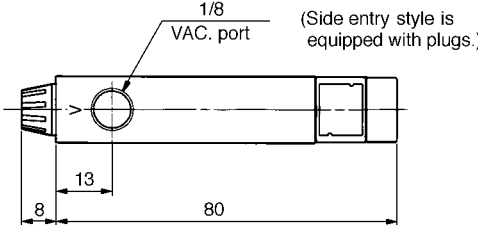
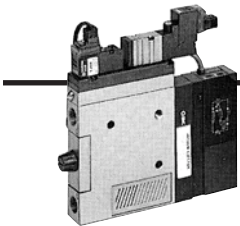

- ZX
- ZR
- ZM**
- ZY
- ZH
- ZU
- ZL
- ZF
- ZP
- ZCU
- Vacuum related

## Manifold Specifications: Series ZM

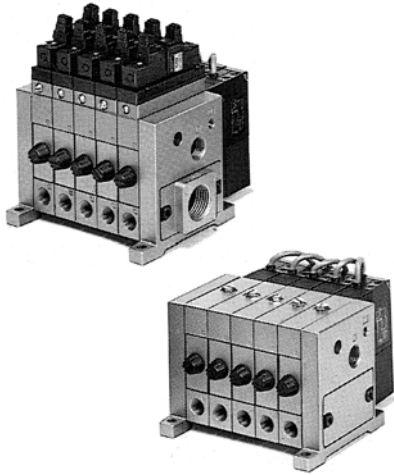

### Manifold Specifications

Manifold style	Stacking
Common SUP port*	Rc(PT) 1/4
Individual SUP port*	Rc(PT) 1/8
Common EXH port	Rc(PT) 1/2, 3/4
EXH port location	Right side/Left side/Both sides**
Max. number of stations	Max. 10 stations
Silencer	ZZM-SA(with bolts)

\*Mixed mounting of common SUP and individual SUP types possible.

\*\*Right or left to the VAC port.

### Maximum Ejector Stations

Ejector model	ZM053	ZM073	ZM103	ZM133
	ZM054	ZM074	ZM104	ZM134
ZZM Stations -06 <sup>R</sup> <sub>L</sub>	10	8	5	4
ZZM Stations -06B	10	10	8	6
ZZM Stations -04 <sup>R</sup> <sub>L</sub>	10	8	5	4
ZZM Stations -04B	10	10	8	6

\*Effective area of external silencer is 160mm<sup>2</sup>.

### How to Order Ejector Manifold

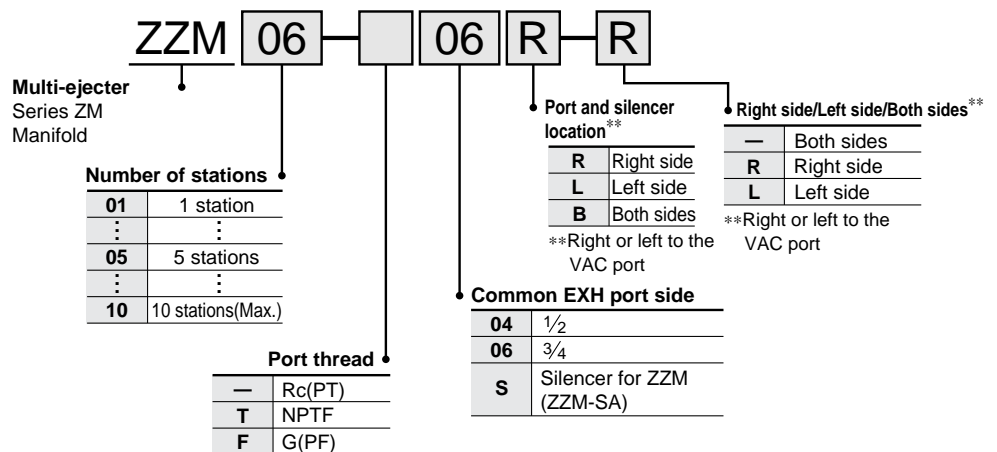

\*Indicate the ejector model no. below the manifold base no.

<Ordering Example>

Manifold: ZZM06-06R(1 pc.)

Ejector: ZM103H-J5LZ(3 pcs.)

ZM133H-J5LZ(3 pcs.)

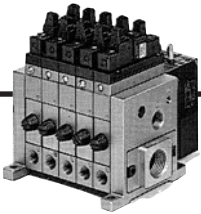

## Manifold

ZM Stations of the ejector — Common EXH port — Port location

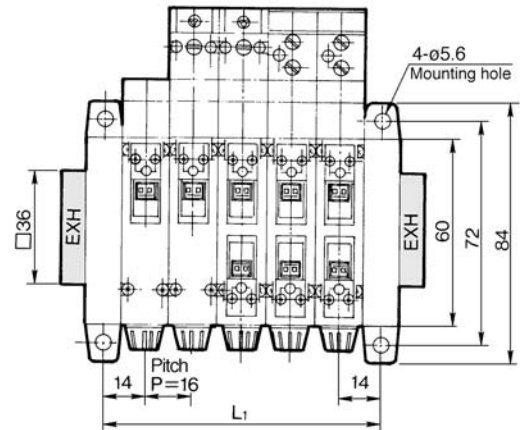
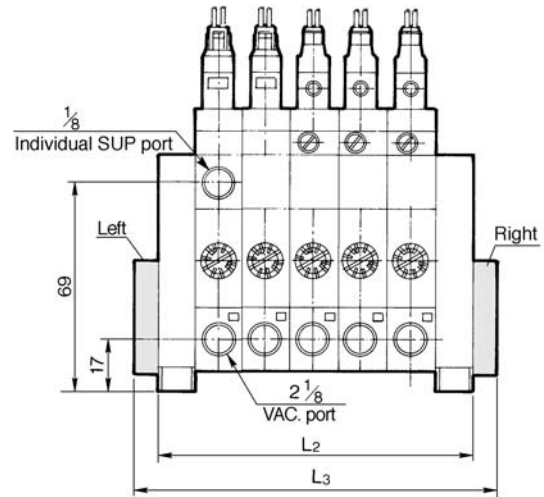
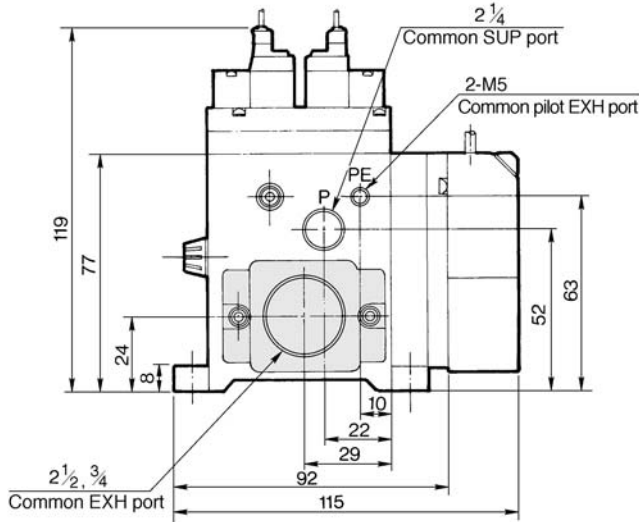

ZX

ZR

**ZM**

ZY

ZH

ZU

ZL

ZF

ZP

ZCU

Vacuum related

(mm)											
L	Stations	1	2	3	4	5	6	7	8	9	10
	L1	28	44	60	76	92	108	124	140	156	172
	L2	40	56	72	88	104	120	136	152	168	184
	L3	56	72	88	104	120	136	152	168	184	200

# Series ZM

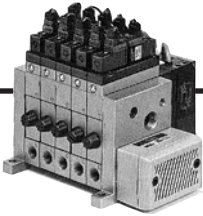

## Manifold/With Silencer

### ZM Stations of the ejector – S Silencer location

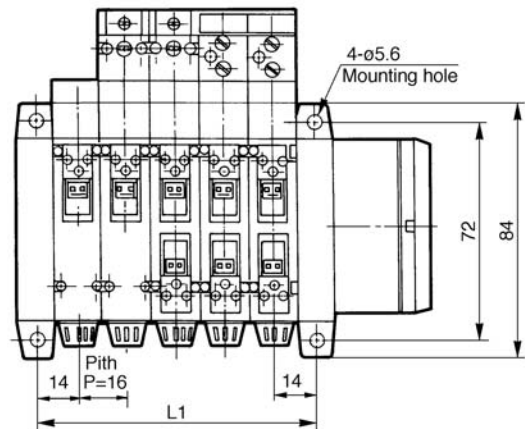
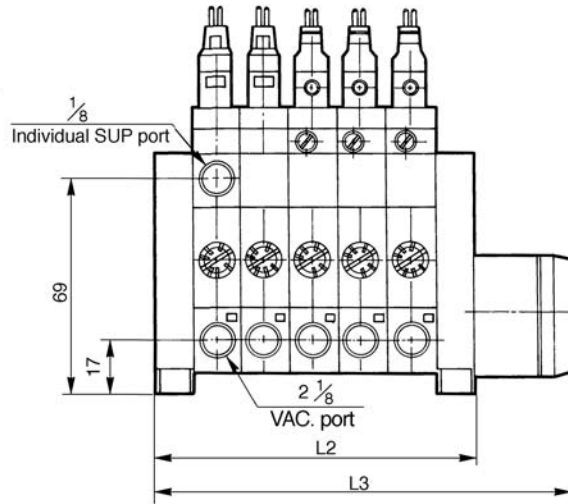
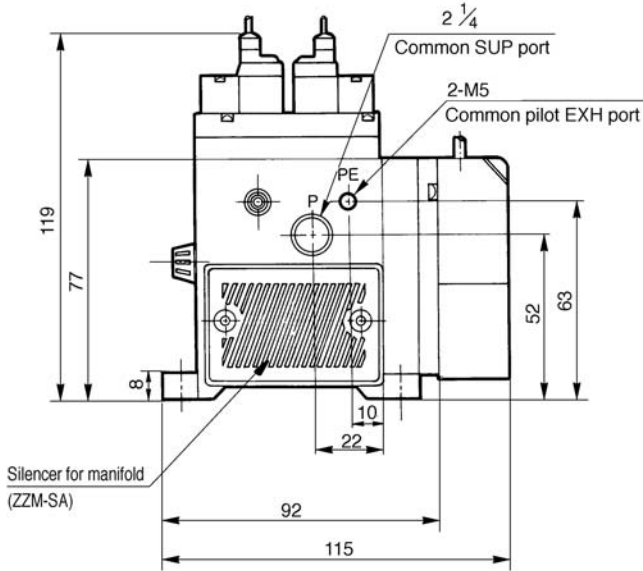

VAC. port electrical entry (In case of side entry/With plug at the bottom)

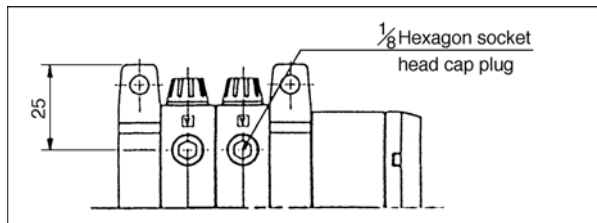

Stations	1	2	3	4	5	6	7	8	9	10
L1	28	44	60	76	92	108	124	140	156	172
L2	40	56	72	88	104	120	136	152	168	184
L3	72	88	104	120	136	152	168	184	200	216

(mm)



# Series ZM (Consult SMC for detailed specifications, dimensions, and delivery.)

## Made to Order Specifications



### ① Double Check Valve/For Manifold

Single: ZM Nozzle dia. Body Supply pressure Valve Voltage Electrical entry X107

↓ Double check valve

When a manifold is used, the exhaust that is discharged to the silencer could flow out to the vacuum port side. To prevent this from occurring, a check valve is used.

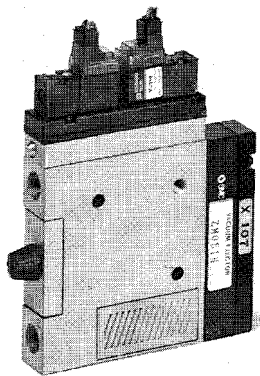

#### ⚠ Warning

- ① It cannot be used for maintaining a vacuum.
- ② Use a vacuum release valve (the workpiece cannot be released without a vacuum release valve.)

ZX

ZR

**ZM**

ZY

ZH

ZU

ZL

ZF

ZP

ZCU

Vacuum related

### Construction

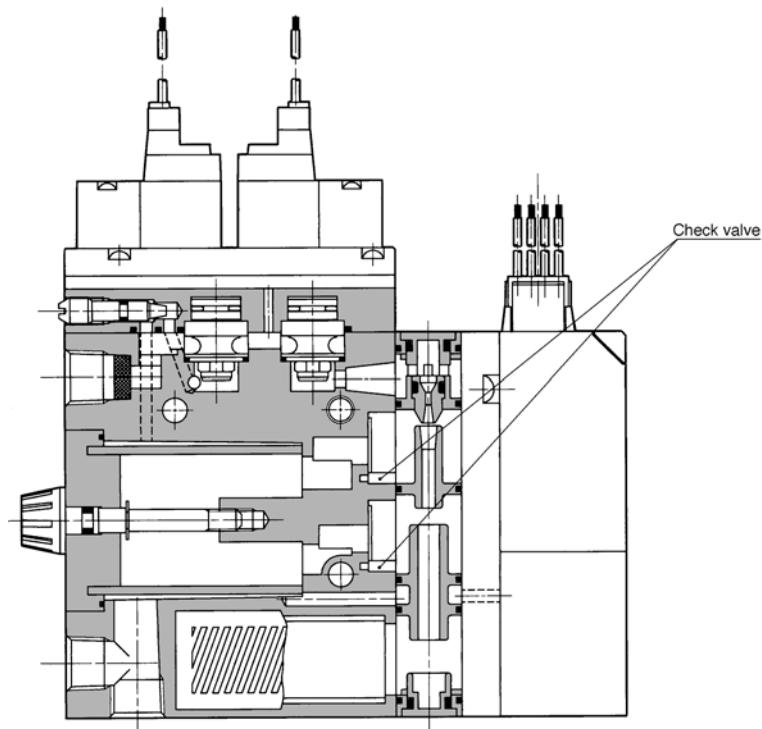

# Series ZM (Consult SMC for detailed specifications, dimensions, and delivery.)

## Made to Order Specifications

### ② With Individual Exhaust Spacer

Single: ZM Nozzle dia. Body Supply pressure — X111  
↓ Individual exhaust spacer

When using an individual ejector in a clean room, the exhaust can be discharged outside of the clean room by attaching an individual exhaust spacer. (The spacer can also be installed when using a manifold. Contact SMC for mounting dimensions.)

\*It is possible to manufacture it with a switch.

#### **Caution**

To connect a pipe to the exhaust port, do not use an elbow joint because it creates resistance and prevents the system from attaining a sufficient vacuum.

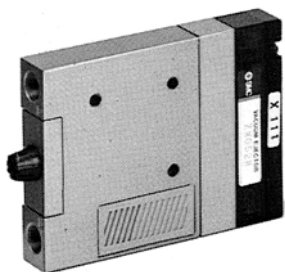

### Construction

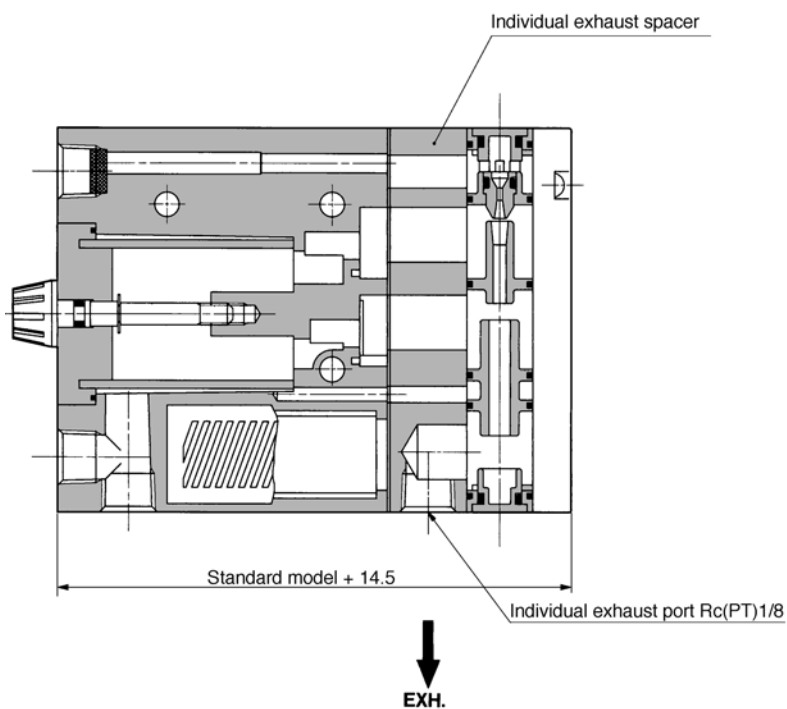

# Series ZM (Consult SMC for detailed specifications, dimensions, and delivery.)

## Made to Order Specifications

### ③ Double Solenoid Supply Valve

Single: ZM **Nozzle dia.** **Body** **Supply pressure** **Valve** **Voltage** **Electrical entry** **X126**

Double solenoid valve	
-X126	With release valve
-X135	Without release valve

This is an air supply pilot valve that is made with double solenoids.  
\*It is possible to manufacture it with a switch.

Note) The -X126 model cannot be manufactured with an L plug connector for electrical entry. Therefore, use a grommet type or an M plug connector.

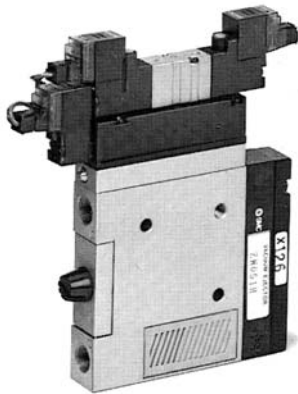

#### Construction

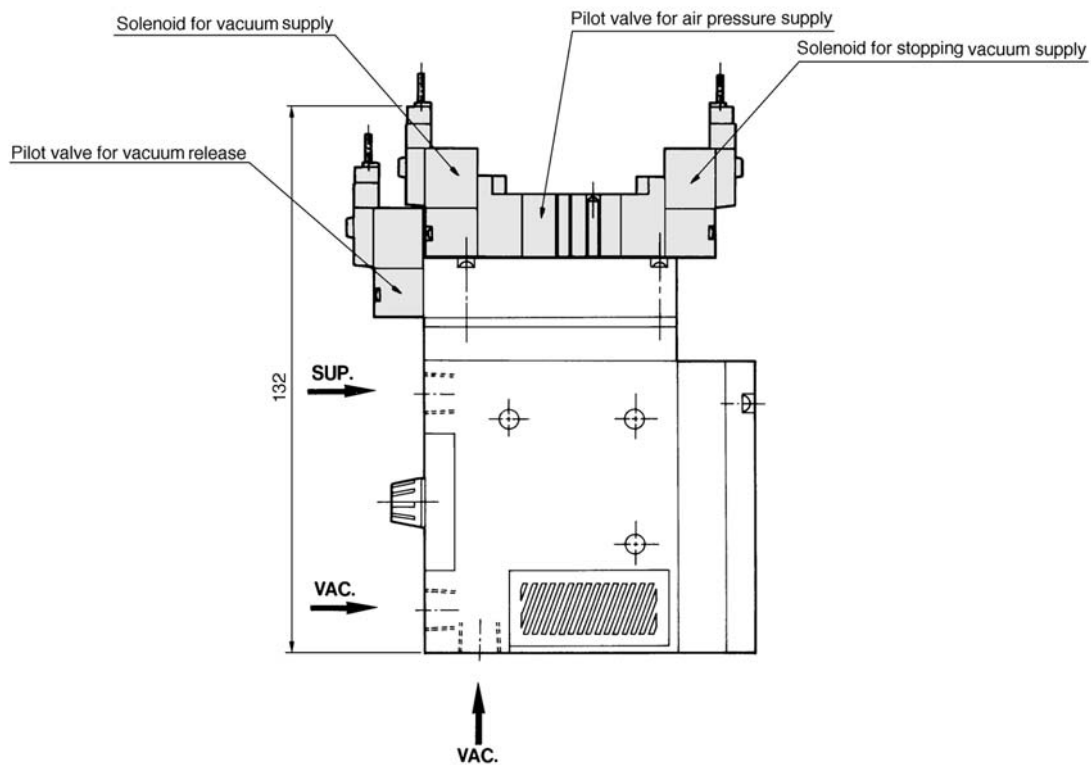

ZX

ZR

**ZM**

ZY

ZH

ZU

ZL

ZF

ZP

ZCU

Vacuum related

