

3 Port Direct Operated Poppet
Solenoid Valve
Series VKF300



3 Port Direct Operated Poppet Solenoid Valve

Series VKF300

Compact with large flow rate

Body width 18mm
Cv0.25 (Standard: Base mounted type)
Cv0.20 (Standard: Body ported type)

Can be used for vacuum (-101.2kPa)

(valve leakage 0.03cm³/s or less with He)
Can be used in vacuum/release circuits

Universal porting type

N.C./N.O. type can be switched by supplying air to port 1(P) or 3(R).
2 way valves and selector valves can also be freely used.

Ozone resistant (Series 80-)

FKM (fluororubber) is used for the fluid-contact rubber materials, allowing use even in ozone environments.

Various manifold piping directions

Output port: Manifold set-up allowing 360° rotation of 2(A) entry direction (in 90° increments)

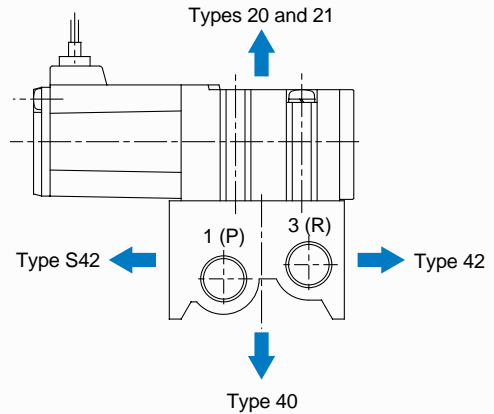

Easy manual operation

Since manual overrides are located in 2 directions, on the top and on the side of the valve, manual override operation is possible unaffected by mounting space and piping direction, etc.

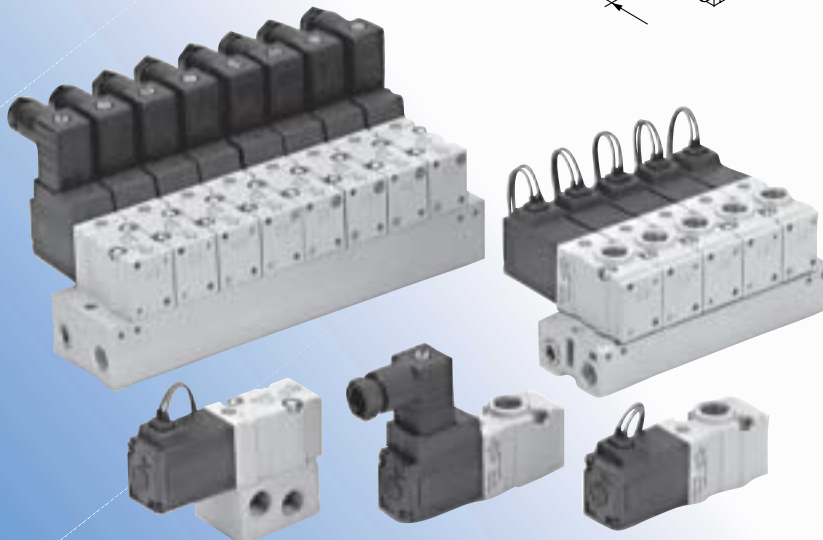
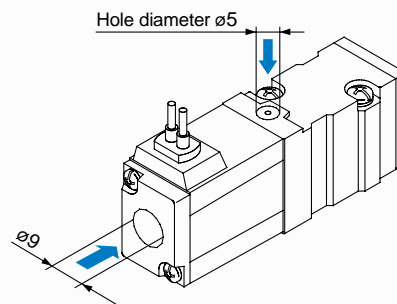

3 Port Direct Operated Poppet

3 Port Direct Operated Poppet Solenoid Valve

Series VKF300

How to Order Valves



Rated voltage

1	100VAC 50/60 Hz
2	200VAC 50/60 Hz
3*	110VAC 50/60 Hz
4*	220VAC 50/60 Hz
5	24VDC
6*	12VDC
7*	240VAC 50/60 Hz
9	Other

* Order made

Electrical entry

G-grommet (lead wire length: 300mm) 	H-grommet (lead wire length: 600mm) 	D-DIN type terminal 	DO-DIN terminal* (without connector)
24VDC, 12VDC only		All rated voltages	

Port size

M5	M5 x 0.8
01	Rc(PT) 1/8 (port A)

Body ported (single type)	VKF332	□	5	G	□	M5 (with bracket)
Body ported (for manifold)	VKF333	□	5	G	□	M5
Base mounted	VKF334	□	5	G	□	01



Valve option

V	For vacuum
Y*	For low power consumption
W*	For vacuum/low power consumption
E*	For long loading time

* Please inquire separately regarding applicable voltage.

Light/Surge voltage suppressor

Nil	None
S	With surge voltage suppressor
Z	With light/surge voltage suppressor (D type only)

* Since the light is built into the connector, there is no DOZ part number.

Port size

01	Rc(PT) 1/8 (with sub plate)
Nil	Without sub plate

Models

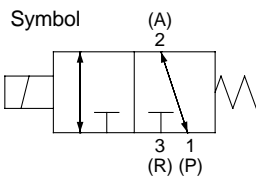

Valve model		Operating pressure range MPa {kgf/cm ² }	Port size	Effective area mm ² (Cv factor)	Weight g (grommet type)
Body ported	VKF332	0 to 0.7 {0 to 7.1}	M5 x 0.8 Rc(PT) 1/8	3.6 (0.2)	80 ^{Note 1)}
	VKF332Y (for low power consumption, DC2W)			2.7 (0.15)	
	VKF332E (for long loading time)			2.7 (0.15)	
	VKF332V (for vacuum)	-101.2kPa to 0.1 {1Torr to 1}		3.6 (0.2)	
	VKF332W (for low power consumption/vacuum)			2.7 (0.15)	
Base mounted	VKF334	0 to 0.7 {0 to 7.1}	Rc(PT) 1/8	4.5 (0.25)	120
	VKF334Y (for low power consumption, DC2W)			2.7 (0.15)	
	VKF334E (for long loading time)			2.7 (0.15)	
	VKF334V (for vacuum)	-101.2kPa to 0.1 {1Torr to 1}		4.5 (0.25)	
	VKF334W (for low power consumption/vacuum)			2.7 (0.15)	

Note 1) VKF332 (with bracket): Add 10g to each when equipped with bracket.

Series VKF300



Body ported type



Base mounted type

Symbol

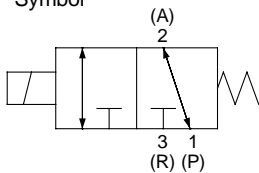

Standard specifications

Valve specifications	Type of actuation		Direct operated type 2 position single solenoid	
	Fluid		Air	
	Ambient and fluid temperature		Maximum 50°C	
	Response time (at 0.5MPa (5.1kgf/cm ²)) ^{Note 1)}		10ms or less (standard), 15ms or less (low power consumption type)	
	Manual operation		Non-locking push type	
	Lubrication		Not required (if lubricated, use class 1 turbine oil ISO VG32)	
	Mounting orientation		Unrestricted	
	Impact/Vibration resistance ^{Note 2)}		300/50 m/s ²	
	Enclosure		Dust proof	
	Electrical entry		Grommet (G), DIN terminal (D)	
Electrical specifications	Rated voltage	AC	100V, 110V, 200V, 220V, 240V	
		DC	6V, 12V, 24V, 48V	
	Allowable voltage fluctuation		±10% of rated voltage	
	Apparent power (AC)	Standard	Starting	9.5VA/50Hz, 8VA/60Hz
			Holding	7VA/50Hz, 5VA/60Hz
		Long loading time	Starting	3.5VA/50Hz, 3.3VA/60Hz
			Holding	3VA/50Hz, 2.8VA/60Hz
	Power consumption (DC)	Without light	4W (standard), 2W (low power consumption type)	
		With light	4.3W (standard), 2.3W (low power consumption type)	
	Surge voltage suppressor	AC	Varistor	
DC		Diode (varistor for 12VDC or less)		
Indicator light	AC	Neon bulb		
	DC	LED		

Note 1) Based on JIS B8374-1981 dynamic performance test. (coil temperature 20°C, at rated voltage, without surge voltage suppressor)

* When equipped with DC solenoid/surge voltage suppressor, a delay of about 20 to 30msec occurs in the OFF response time.

Note 2) Impact resistance: No malfunction when tested with a drop tester in the axial direction and at right angles to the main valve and armature, one time each in both an energized and deenergized state. (initial value)

Vibration resistance: No malfunction when tested with one sweep of 8.3 to 2000Hz in the axial direction and at right angles to the main valve and armature, one time each in both an energized and deenergized state. (initial value.)

Construction

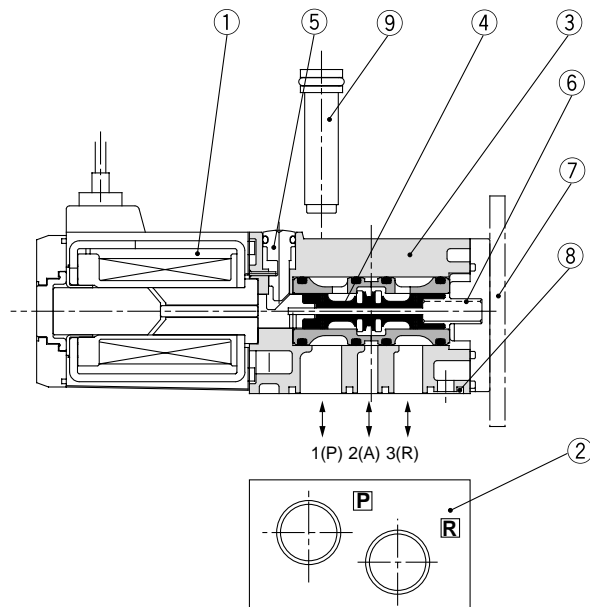

Parts list

No.	Description	Material	Note
1	Solenoid coil assembly	—	
2	Sub plate	Die-cast aluminum	For VKF334: VKF300-S-F or ^{M5} ₀₁
3	Body	Die-cast aluminum	
4	Spool/Sleeve	Aluminum	
5	Manual override	Resin	
6	Return spring	Stainless steel	
7	Bracket assembly	Steel	For VKF332: VKF300-13A-2
8	Gasket assembly (with mounting screw)	—	For VKF333: VKF300-11A-2 For VKF334: VKF300-11A-1
9	Bushing assembly	Resin	For VKF333: VKF300-6A-1 2 sets per unit required

3 Port Direct Operated Poppet *Series VKF300*

Dimensions/Single Type

Body ported type

Grommet: VKF332□-□G-M5₀₁

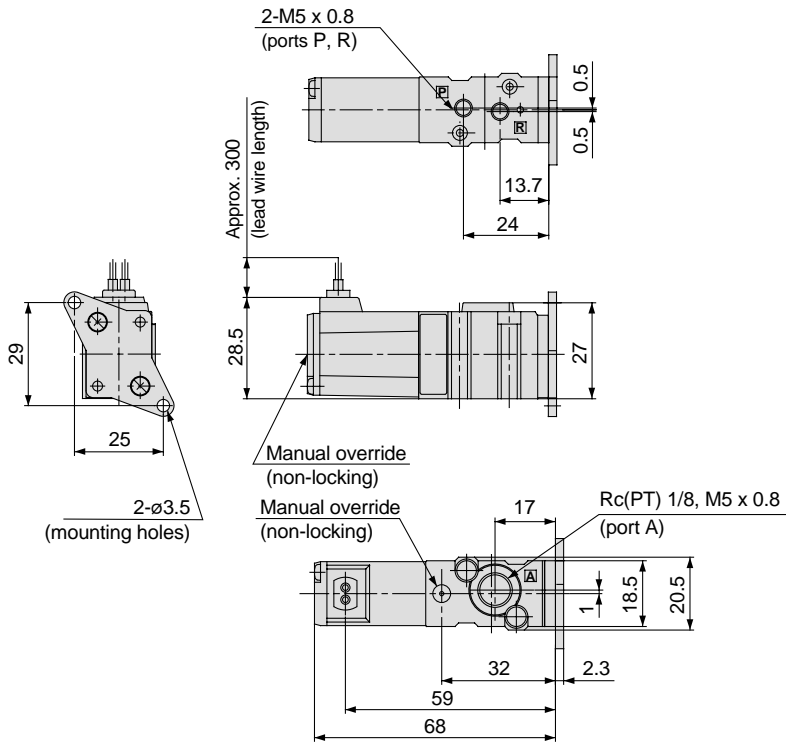

DIN terminal: VKF332□-□D-M5₀₁

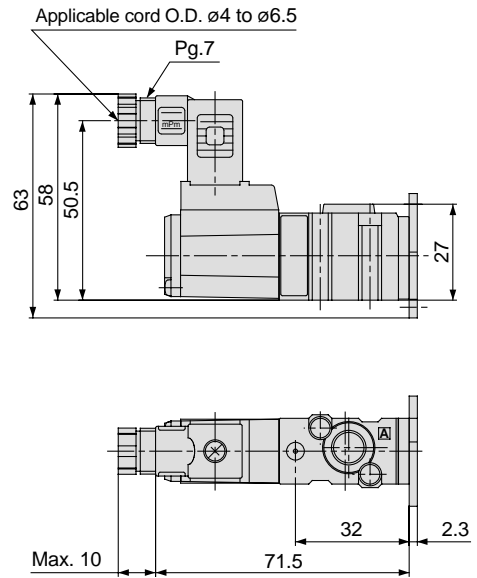

See grommet type for other dimensions.

Base mounted type

Grommet: VKF334□-□G-01

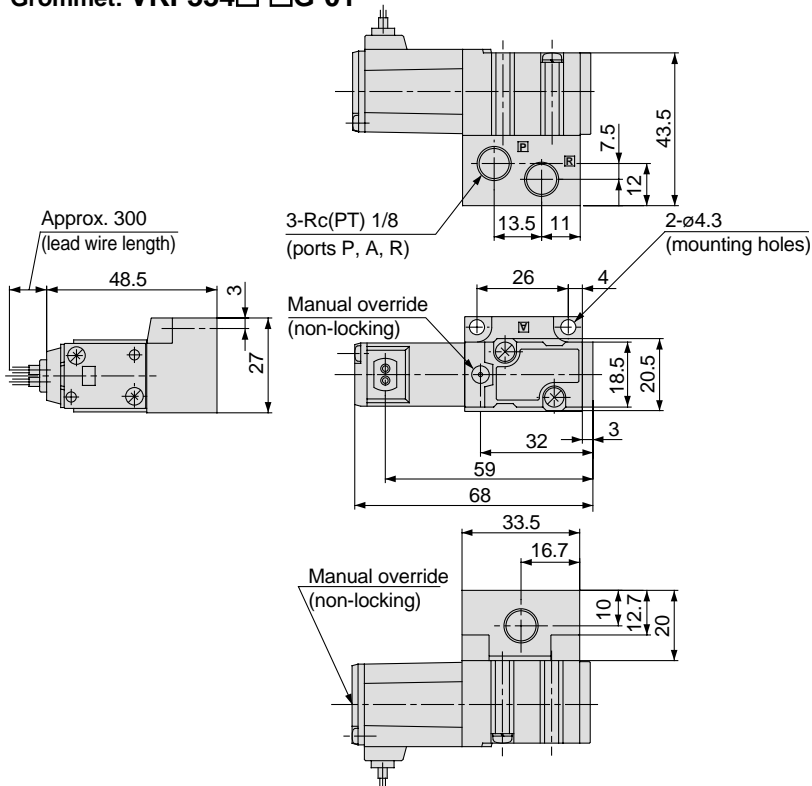

DIN terminal: VKF334□-□D-01

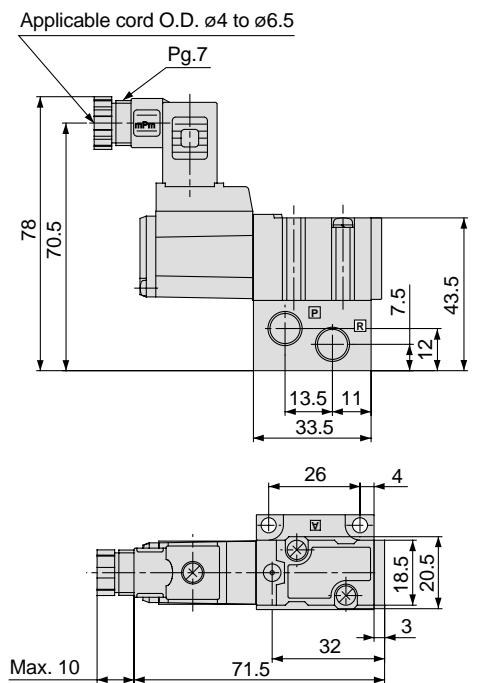

See grommet type for other dimensions.

Series VKF300

How to Order Manifolds

Body Ported Type

Common SUP, Common EXH

Type 20/for body ported type
(Port A top ported)

Port A:
Rc(PT) 1/8, M5 x 0.8

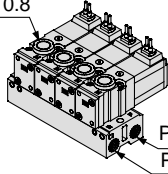

Port P: Rc(PT) 1/8
Port R: Rc(PT) 1/8

How to Order

VV3KF3-20 — 05 — []

Valve stations

01	1 station
⋮	⋮
20	20 stations

Option

Nil	None
F	With bracket (not mounted)

Applicable solenoid valves
VKF333□-□□□-M5
VKF333□-□□□-01

Applicable blanking plate assembly
VK300-42-1A

Bracket
VK300-43-1A

Common SUP, Individual EXH

Type 21/for body ported type
(Port A top ported)

Port A:
Rc(PT) 1/8, M5 x 0.8

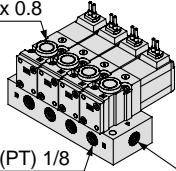

Port R: Rc(PT) 1/8 Port P: Rc(PT) 1/8

How to Order

VV3KF3-21 — 05 — []

Valve stations

01	1 station
⋮	⋮
20	20 stations

Applicable solenoid valves
VKF333□-□□□-M5
VKF333□-□□□-01

Applicable blanking plate assembly
VK300-42-1A

Base Mounted Type

Common SUP, Common EXH

Type 40/for base mounted type
(Port A bottom ported)

How to Order

VV3KF3-40 — 05 — 01 — []

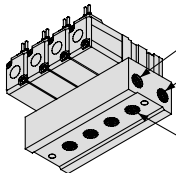

Port P: Rc(PT) 1/8
Port R: Rc(PT) 1/8
Port A: Rc(PT) 1/8

Valve stations

01	1 station
⋮	⋮
20	20 stations

Option

Nil	None
F	With bracket (not mounted)

Port size

01	Rc(PT) 1/8
----	------------

Applicable solenoid valves
VKF334□-□□□

Applicable blanking plate assembly
VK300-42-1A

Bracket
VK300-43-1A

Type 42/for base mounted type
(Port A side ported)

How to Order

VV3KF3 — [] 42 — 05 — 01

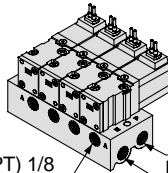

Port A: Rc(PT) 1/8 Port P: Rc(PT) 1/8
Port R: Rc(PT) 1/8

Solenoid direction

Nil	Solenoid on side opposite port A
S	Solenoid on same side as port A

Port size

01	Rc(PT) 1/8
C4	ø4 cassette
C6	ø6 cassette

Applicable solenoid valves
VKF334□-□□□

Applicable blanking plate assembly
VK300-42-1A

Type S42 (solenoid on same side as port A)

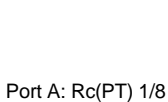

Port P: Rc(PT) 1/8
Port R: Rc(PT) 1/8

Valve stations

01	1 station
⋮	⋮
20	20 stations

3 Port Direct Operated Poppet *Series VKF300*

Dimensions/Manifolds

Body Ported Type

Type 20 Manifold Common SUP, Common EXH/Top Ported

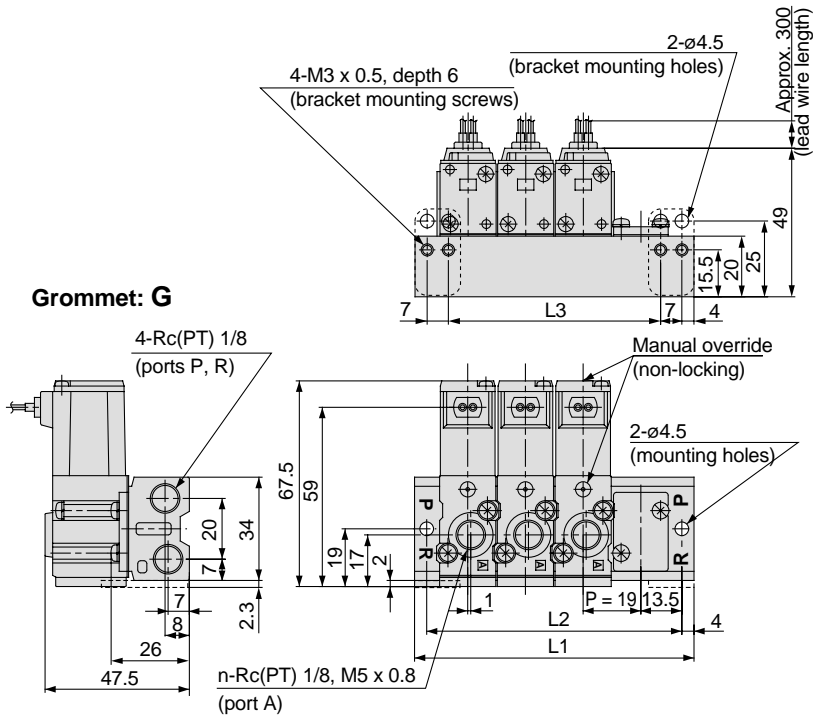

DIN terminal: D

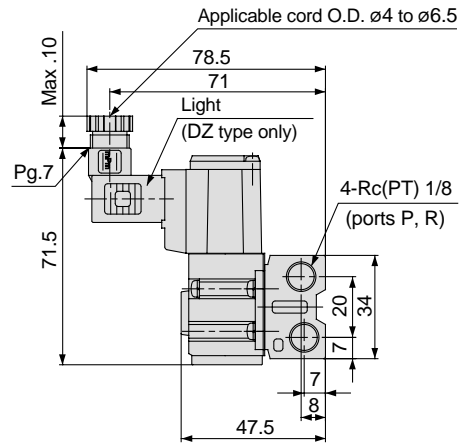

L: Dimension table

n: Stations

L \ n	1	2	3	4	5	6	7	8	9	10	11	12	13	14	15	16	17	18	19	20
L1	35	54	73	92	111	130	149	168	187	206	225	244	263	282	301	320	339	358	377	396
L2	27	46	65	84	103	122	141	160	179	198	217	236	255	274	293	312	331	350	369	388
L3	13	32	51	70	89	108	127	146	165	184	203	222	241	260	279	298	317	336	355	374

Type 21 Manifold Common SUP, Individual EXH/Top Ported

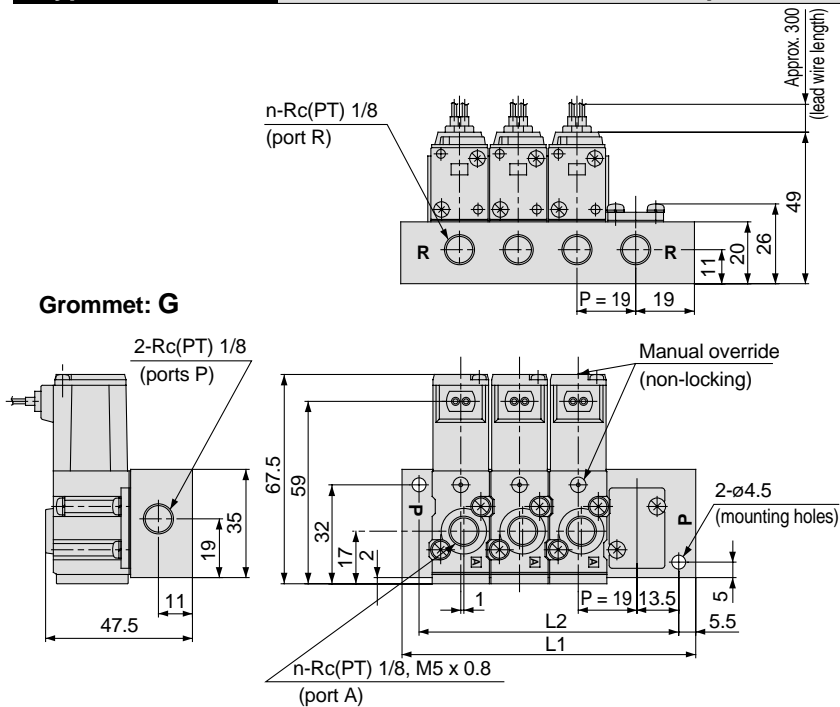

DIN terminal: D

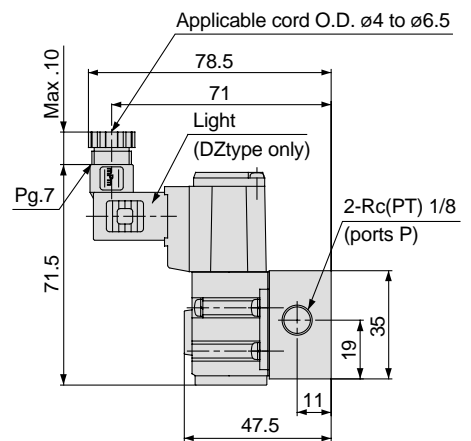

L: Dimension table

n: Stations

L \ n	1	2	3	4	5	6	7	8	9	10	11	12	13	14	15	16	17	18	19	20
L1	38	57	76	95	114	133	152	171	190	209	228	247	266	285	304	323	342	361	380	399
L2	27	46	65	84	103	122	141	160	179	198	217	236	255	274	293	312	331	350	369	388

Series VKF300

Dimensions/Manifolds

Base Mounted Type

Type 40 Manifold Common SUP, Common EXH/Bottom Ported

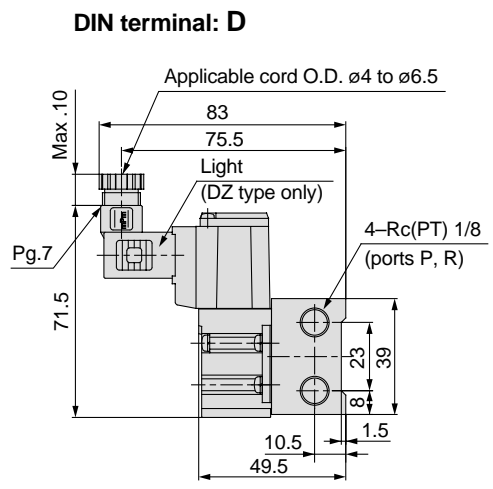
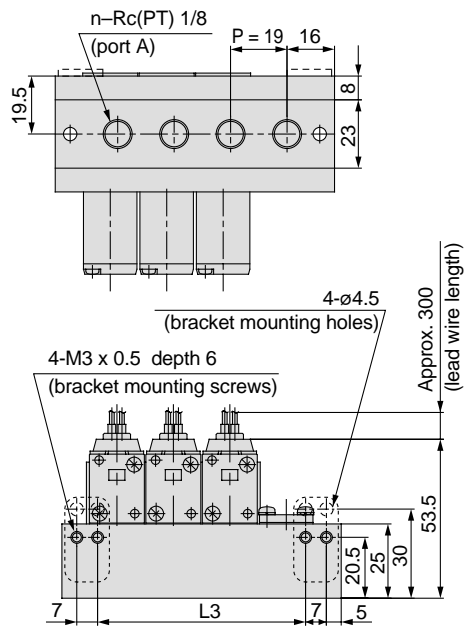

Grommet: G

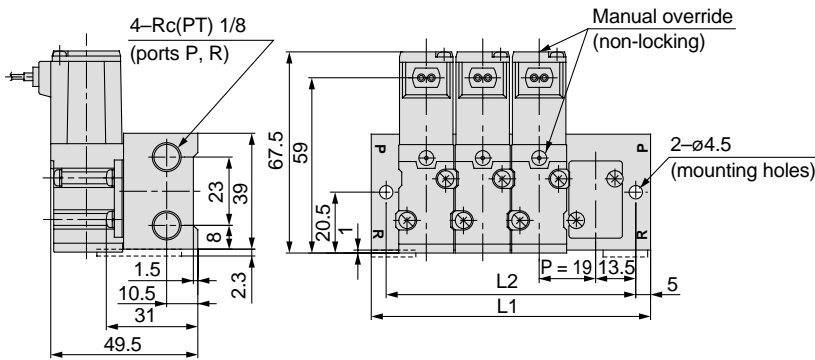

L: Dimension table

n: Stations

L \ n	1	2	3	4	5	6	7	8	9	10	11	12	13	14	15	16	17	18	19	20
L1	37	56	75	94	113	132	151	170	189	208	227	246	265	284	303	322	341	360	379	398
L2	27	46	65	84	103	122	141	160	179	198	217	236	255	274	293	312	331	350	369	388
L3	13	32	51	70	89	108	127	146	165	184	203	222	241	260	279	298	317	336	355	374

3 Port Direct Operated Poppet *Series VKF300*

Base Mounted Type

Type 42 Manifold Common SUP, Common EXH/Side Ported

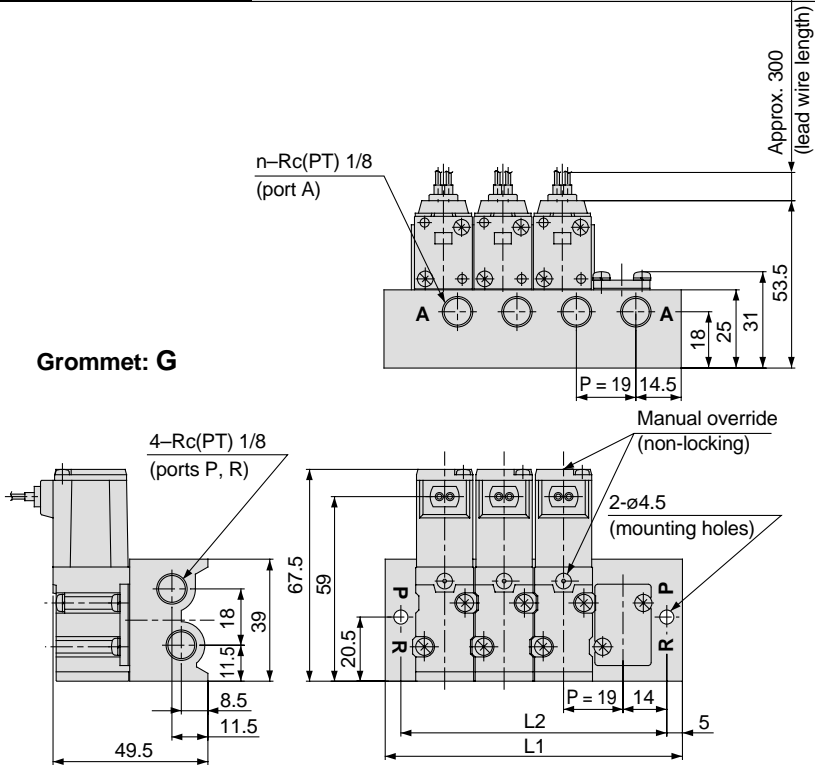

DIN terminal: D

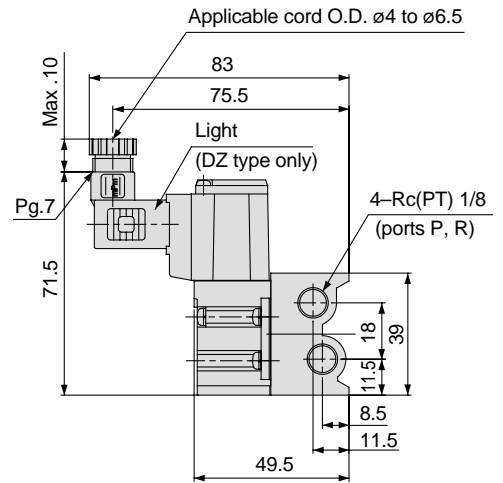

Type S42 Manifold Common SUP, Common EXH/Side Ported: Same direction as solenoid

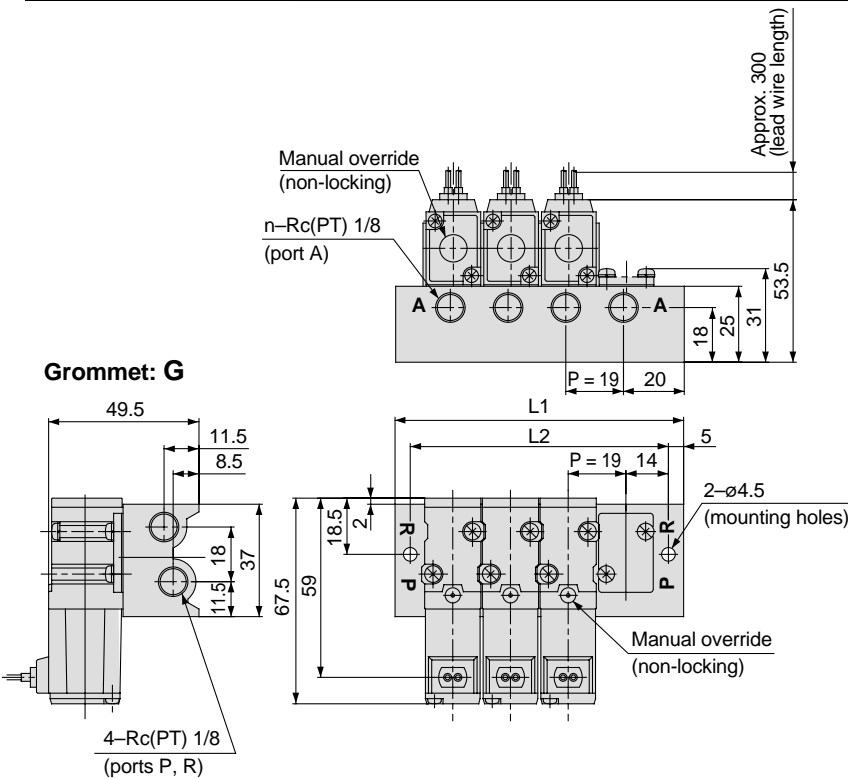

DIN terminal: D

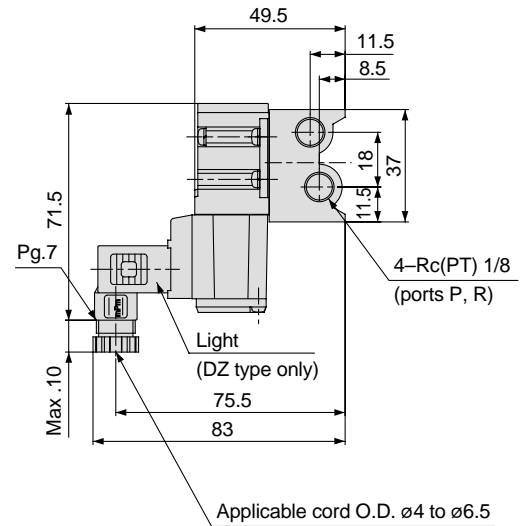

L: Dimension table

L \ n	1	2	3	4	5	6	7	8	9	10	11	12	13	14	15	16	17	18	19	20
L1	38	57	76	95	114	133	152	171	190	209	228	247	266	285	304	323	342	361	380	399
L2	28	47	66	85	104	123	142	161	180	199	218	237	256	275	294	313	332	351	370	389

n: Stations





Series VKF300

Safety Instructions

These safety instructions are intended to prevent a hazardous situation and/or equipment damage. These instructions indicate the level of potential hazard by a label of "**Caution**", "**Warning**" or "**Danger**". To ensure safety, be sure to observe ISO 4414 Note 1), JIS B 8370 Note 2) and other safety practices.

 **Caution** : Operator error could result in injury or equipment damage.

 **Warning** : Operator error could result in serious injury or loss of life.

 **Danger** : In extreme conditions, there is a possible result of serious injury or loss of life.

Note 1) ISO 4414 : Pneumatic fluid power – Recommendations for the application of equipment to transmission and control systems.

Note 2) JIS B 8370 : Pneumatic system axiom.

Warning

1. The compatibility of pneumatic equipment is the responsibility of the person who designs the pneumatic system or decides its specifications.

Since the products specified here are used in various operating conditions, their compatibility for the specific pneumatic system must be based on specifications or after analysis and/or tests to meet your specific requirements.

2. Only trained personnel should operate pneumatically operated machinery and equipment.

Compressed air can be dangerous if an operator is unfamiliar with it. Assembly, handling or repair of pneumatic systems should be performed by trained and experienced operators.

3. Do not service machinery/equipment or attempt to remove components until safety is confirmed.

1. Inspection and maintenance of machinery/equipment should only be performed after confirmation of safe locked-out control positions.
2. When equipment is to be removed, confirm the safety process as mentioned above. Cut the supply pressure for this equipment and exhaust all residual compressed air in the system.
3. Before machinery/equipment is restarted, take measures to prevent shooting-out of cylinder piston rod, etc. (Bleed air into the system gradually to create back-pressure.)

4. Contact SMC if the product is to be used in any of the following conditions:

1. Conditions and environments beyond the given specifications, or if product is used outdoors.
2. Installation on equipment in conjunction with atomic energy, railway, air navigation, vehicles, medical equipment, food and beverages, recreation equipment, emergency stop circuits, press applications, or safety equipment.
3. An application which has the possibility of having negative effects on people, property, or animals, requiring special safety analysis.



Series VKF300

3 Port Solenoid Valve/Precautions 1

Be sure to read before handling.

Precautions on Design

Warning

1. Actuator drive

When an actuator, such as a cylinder, is to be driven using a valve, take appropriate measures to prevent potential danger caused by actuator operation.

2. Effect of back pressure when using a manifold

Use caution when valves are used on a manifold, as actuator malfunction due to back-pressure may occur. Implement countermeasures in cases where there is a danger of this kind of malfunction.

3. Pressure

Since valves are subject to air leakage, they cannot be used for applications such as holding pressure in a pressure vessel.

Moreover, when used for vacuum, use type m.

4. Cannot be used as an emergency shutoff valve, etc.

The valves presented in this catalog are not designed for safety applications such as an emergency shutoff valve. If the valves are used in this type of system, other reliable safety assurance measures should also be adopted.

5. Maintenance space

The installation should allow sufficient space for maintenance activities.

6. Release of residual pressure

Provide a residual pressure release function for maintenance purposes.

7. Vacuum applications

When a valve is used for vacuum switching, etc., take measures against the suction of external dust or other contaminants from vacuum pads and exhaust ports, etc.

Selection

Warning

1. Confirm the specifications.

The products presented in this catalog are designed only for use in compressed air systems. Do not operate at pressures or temperatures, etc. beyond the range of specifications, as this can cause damage or malfunction. (Refer to specifications.)

Contact SMC when using a fluid other than compressed air.

2. Long continuous loading time

When power will be applied continuously for extended periods of time, use type VKF330E. However, it cannot be used with high frequency. Contact SMC if it will be operated more than once a day.

3. Be sure to perform switching at least once every 30 days.

Caution

1. Leakage voltage

Particularly when using a resistor in parallel with a switching element, take note that leakage voltage will increase due to leakage current flowing through the resistor.

Limit the amount of residual

leakage voltage to the following values.

For AC coil: 20% or less of rated voltage

For DC coil: 2% or less of rated voltage

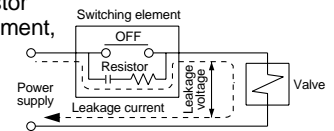

2. Low temperature operation

Operation is possible to -10°C , but measures should be taken to avoid solidification or freezing of drainage and moisture, etc.

3. Mounting orientation

The mounting orientation is unrestricted.

Mounting

Warning

1. If air leakage increases or equipment does not operate properly, stop operation of the valve.

At the time of mounting and maintenance, etc., connect the compressed air and power supplies, and perform appropriate function and leakage inspections to confirm that the unit is mounted properly.

2. Instruction manual

Mount and operate the product after reading the manual carefully and understanding its contents. Also keep the manual where it can be referred to as necessary.

3. Painting and coating

Warnings or specifications printed or pasted on the product should not be erased, removed or covered up.



Series VKF300

3 Port Solenoid Valve/Precautions 2

Be sure to read before handling.

Piping

⚠ Caution

1. Preparation before piping

Before piping is connected, it should be thoroughly blown out with air (flushing) or washed to remove cutting chips, cutting oil and other debris from inside the pipe.

2. Wrapping of pipe tape

When connecting pipes and fittings, etc., be sure that cutting chips from the pipe threads and sealing material do not get inside the valve.

Further, when pipe tape is used, leave 1.5 to 2 thread ridges exposed at the end of the pipe/fitting.

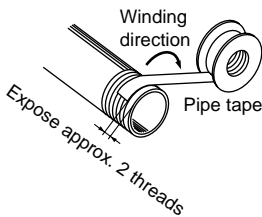

3. Always fasten threads with the proper tightening torque.

When screwing fittings into valves, fasten with the proper tightening torques as shown below.

Tightening torque for piping

Connection threads	Proper tightening torque N·m {kgf·cm}
M5	1.5 to 2 {15 to 20}
Rc(PT) 1/8	7 to 9 {71 to 92}

Reference:

Tightening into the M5 fitting threads

After tightening by hand, tighten about 1/6 of a turn further using a tightening tool. (In the case of universal elbows and universal tees, etc., which have gaskets in 2 places, tighten by an additional 1/2 turn.)

4. Connection of piping to products

When connecting piping to a product, refer to its instruction manual to avoid mistakes regarding the supply port, etc.

Wiring

⚠ Caution

1. Polarity

When connecting power to a DC specification solenoid valve equipped with light/surge voltage suppressor, confirm whether or not there is polarity.

If there is polarity, take note of the following points.

- Without AC and DC light/surge suppressor: Non-polar type
- With DC light/surge suppressor:

If a mistake is made regarding polarity, it will not be possible to switch the valve.

2. Applied voltage

When electric power is connected to the solenoid valve, be careful to apply the proper voltage. Improper voltage may cause malfunction or coil damage.

3. Confirm the connections.

After completing the wiring, confirm that the connections are correct.

Lubrication

⚠ Caution

1. Lubrication

1) The valve has been lubricated for life at the factory, and does not require any further lubrication.

2) In the event that it is lubricated, use Class 1 turbine oil (without additives), ISO VG32.

However, once lubrication is applied it must be continued, as the original lubricant may be eliminated leading to malfunction.

Air Supply

⚠ Warning

1. Use clean air.

Do not use compressed air which contains chemicals, synthetic oils containing organic solvents, salts or corrosive gases, etc., as this can cause damage or malfunction.

⚠ Caution

1. Install air filters.

Install air filters close to valves at their upstream side. A filtration degree of 5µm or less should be selected.

2. Install an air dryer, after cooler, etc.

Air that includes excessive condensate may cause malfunction of valves and other pneumatic equipment. To prevent this, install an air dryer or after cooler etc..

3. If excessive carbon dust is generated, eliminate it by installing mist separators at the upstream side of valves.

If excessive carbon dust is generated by the compressor, it may adhere to the inside of valves and cause malfunction.

Refer to SMC's "Air Cleaning Equipment" catalog for further details on compressed air quality.



Series VKF300

3 Port Solenoid Valve/Precautions 3

Be sure to read before handling.

Operating Environment

⚠ Warning

1. Do not use valves in atmospheres of corrosive gases, chemicals, salt water, water or steam, or where there is direct contact with same.
2. Do not use in an explosive atmosphere.
3. Do not use in locations subject to vibration or impact.
4. A protective cover, etc. should be used to shield valves from direct sunlight.
5. Shield valves from radiated heat generated by nearby heat sources.
6. Employ suitable protective measures in locations where there is contact with water droplets, oil or welding spatter, etc.
7. When solenoid valves are mounted in a control panel or are energized for extended periods of time, employ measures to radiate excess heat, so that temperatures remain within the valve specification range.

Maintenance

⚠ Warning

1. Perform maintenance procedures as shown in the instruction manual.

If handled improperly, malfunction or damage of machinery or equipment may occur.

2. Removal of equipment maintenance and supply/exhaust of compressed air

When equipment is removed, first confirm that measures are in place to prevent dropping of work pieces and run-away of equipment, etc. Then cut the supply pressure and power, and exhaust all compressed air from the system using its residual pressure release function.

When the equipment is to be started again after remounting or replacement, first confirm that measures are in place to prevent lurching of actuators, etc., and then confirm that the equipment is operating normally.

3. Low frequency operation

Valves should be switched at least once every 30 days to prevent malfunction. (Use caution regarding the air supply.)

4. Manual override operation

When the manual override is operated, connected equipment will be actuated. Confirm safety before operating.

Maintenance

⚠ Caution

1. Drain flushing

Remove condensate from air filters regularly. (Refer to specifications.)

2. Lubrication

Once lubrication is applied, it must be continued.

Lubricate with class 1 turbine oil (without additives) VG32. If any other lubricant is used, malfunction or other trouble may occur.

Contact SMC regarding class 2 turbine oil (with additives) VG32.

How to Find the Flow Rate (at air temperature of 20°C)

Subsonic flow when $P_1 + 0.1013 < 1.89 (P_2 + 0.1013)$

$$Q = 226S \sqrt{\Delta P (P_2 + 0.1013)}$$

Sonic flow when $P_1 + 0.1013 \geq 1.89 (P_2 + 0.1013)$

$$Q = 113S (P_1 + 0.1013)$$

Q: Air flow rate [l/min(ANR)]

S: Effective area (mm²)

ΔP: Pressure drop (P₁-P₂) [MPa]

P₁: Upstream pressure [MPa]

P₂: Downstream pressure [MPa]

* Correction for different air temperatures

Multiply the flow rate calculated with the above formula by a coefficient from the table below.

Air temperature (°C)	-20	-10	0	10	30	40	50	60
Correction coefficient	1.08	1.06	1.04	1.02	0.98	0.97	0.95	0.94



Series VKF300 Specific Product Precautions

Be sure to read before handling.
Refer to pages 8 through 11 for safety instructions and precautions.

Manual Override Operation

Warning

Since connected equipment will be actuated when manual override operation is performed, first confirm that conditions are safe.

■ Non-locking push type (tool required)

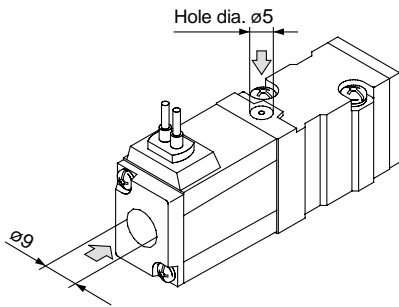

There are manual overrides in 2 directions, on the top and on the side (solenoid side). By pressing either of the manual overrides in the direction of the arrow (→) until it stops (approx. 1mm), it will turn ON, and it turns OFF when released.

Mounting of Valves

Caution

After confirming the installation of the gaskets, securely tighten the screws to the tightening torque shown in the table below.

Proper tightening torque N·m [kgf·cm]
0.6 to 0.8 [6 to 8]

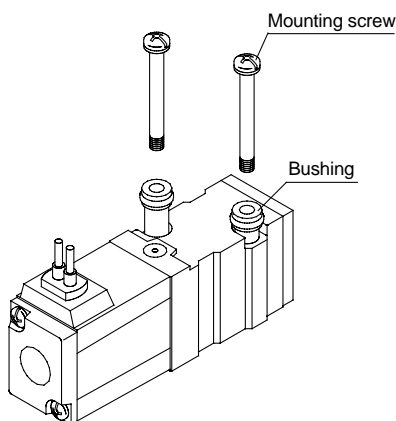

The bushing may be damaged if the tightening torque of 0.8N·m is exceeded. In the event that damage does occur, be sure to replace the bushing.

Bushing assembly part no.	VKF300-6A-1
---------------------------	-------------

• 2 sets per unit are required.

Light/Surge Voltage Suppressor

Caution

	Grommet type (G)	DIN terminal (D)	Part No. symbol
AC	Without light	None	No.1Ⓢ No.2Ⓢ Varistor Coil
	With light	None	No.1Ⓢ No.2Ⓢ Neon bulb Varistor Coil
12 VDC or less	Without light	None	No.1Ⓢ No.2Ⓢ Varistor Coil
	With light	None	No.1Ⓢ No.2Ⓢ LED Varistor Coil
24 VDC or more	Without light	None	No.1 (+) No.2 (-) Diode Coil
	With light	None	No.1 (+) No.2 (-) LED Diode Coil

Precautions on connection of 24V or more DC

For the grommet type, connect the positive (+) side to the red lead wire and connect the negative (-) side to the black lead wire. For the DIN terminal, connect the positive (+) side to the connector's No.1 terminal and connect the negative (-) side to the No.2 terminal. (See the markings on the terminal block.)

* For 12V or less DC, positive (+) and negative (-) can be connected in either direction.

• Grommet type

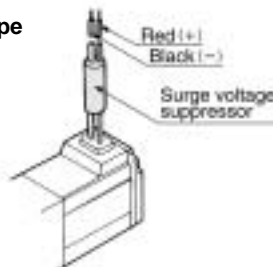

• DIN terminal

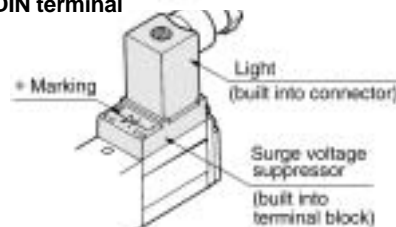

* Markings

For AC and 12V or less DC



For 24V or more DC



Use of the DIN Connector

Caution

• Connection procedure

1. Loosen the holding screw, and pull the connector out of the solenoid valve terminal block.
2. After removing the holding screw, insert a flat head screw driver, etc. into the notch on the bottom of the terminal block and pry it up, separating the terminal block and the housing.
3. Loosen the terminal screws (slotted screws) on the terminal block, insert the core of the lead wire into the terminal in accordance with the prescribed connection method, and attach securely with the terminal screws.
4. Fasten the cord by screwing in the ground nut.

• Cord entry changing procedure

After separating the terminal block and housing, the cord entry direction can be changed by attaching the housing in the desired direction (4 directions in 90° increments).

* When equipped with light, handle with care so that the light is not damaged by the cord's lead wires, etc.

• Precautions

The connector should be inserted and pulled out in a straight line without tilting diagonally.

• Compatible cables

Cord outside diameter: $\varnothing 4$ to $\varnothing 6.5$ (Reference)

0.5mm² equivalent to JISC3306, 2 wire or 3 wire

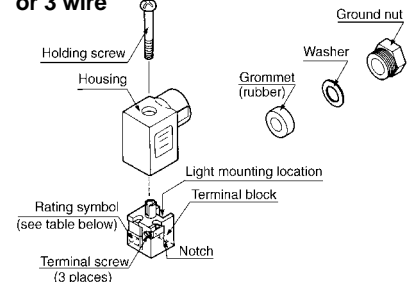

• Connector part no.: VK300-37-1 • Part No. for connector with light

Rated voltage	Rating symbol	Part No.
100VAC	A1	VK300-37-2-01
200VAC	A2	VK300-37-2-02
240VAC	A3	VK300-37-2-07
6VDC	LW06	VK300-37-4-51
12VDC	LW2	VK300-37-4-06
24VDC	LD4	VK300-37-3-05
48VDC	LD8	VK300-37-3-53

• Circuit diagram for connector with light

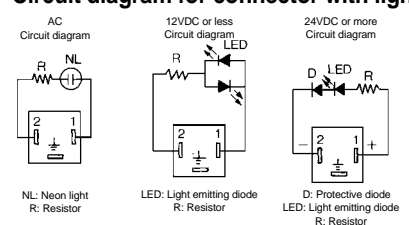

NL: Neon light
R: Resistor

LED: Light emitting diode
R: Resistor

D: Protective diode
LED: Light emitting diode
R: Resistor

**Austria**

SMC Pneumatik GmbH (Austria).
Girakstrasse 8, A-2100 Körneuburg
Phone: 02262-62280, Fax: 02262-62285

**Belgium**

SMC Pneumatics N.V./S.A.
Nijverheidsstraat 20, B-2160 Wommelgem
Phone: 03-355-1464, Fax: 03-355-1466

**Czech**

SMC Czech.s.r.o.
Kodanska 46, CZ-100 10 Prague 10
Phone: 02-67154 790, Fax: 02-67154 793

**Denmark**

SMC Pneumatik A/S
Jens Juuls vej 32, DK-8260 Viby J
Phone: 45-70252900, Fax: 45-70252901

**Estonia**

Teknoma Eesti AS
Mustamäe tee 5, EE-0006 Tallinn, Estonia
Phone: 259530, Fax: 259531

**Finland**

SMC Pneumatikka OY
Veneentekijäntie 7, SF-00210 Helsinki
Phone: 09-681021, Fax: 09-6810233

**France**

SMC Pneumatique, S.A.
1, Boulevard de Strasbourg, Parc Gustave Eiffel
Bussy Saint Georges
F-77607 Marne La Vallée Cedex 3
Phone: 01-6476 1000, Fax: 01-6476 1010

**Germany**

SMC Pneumatik GmbH
Boschring 13-15, D-63329 Egelsbach
Phone: 06103-4020, Fax: 06103-402139

**Greece**

S. Parianopoulos S.A.
9, Konstantinoupoleos Street,
GR-11855 Athens
Phone: 01-3426076, Fax: 01-3455578

**Hungary**

SMC Hungary Kft.
Budafoki ut 107-113, 1117 Budapest
Phone: 01-204 4366, Fax: 01-204 4371

**Ireland**

SMC Pneumatics (Ireland) Ltd.
2002 Citywest Business Campus,
Naas Road, Saggart, Co. Dublin
Phone: 01-403 9000, Fax: 01-464 0500

**Italy**

SMC Italia S.p.A
Via Garibaldi 62, I-20061 Carugate, (Milano)
Phone: 02-92711, Fax: 02-92150394

**Latvia**

Ottensten Latvia SIA
Ciekurkalna Prima Gara Linija 11,
LV-1026 Riga, Latvia
Phone: 371-23-68625, Fax: 371-75-56748

**Lithuania**

UAB Ottensten Lietuva
Savanoriu pr.180, LT-2600 Vilnius, Lithuania
Phone/Fax: 370-2651602

**Netherlands**

SMC Controls BV
De Ruyterkade 120, NL-1011 AB Amsterdam
Phone: 020-5318888, Fax: 020-5318880

**Norway**

SMC Pneumatics (Norway) A/S
Wollseien 13 C, granfoss Nøeringspark
N-134 Lysaker, Norway
Phone: 22 99 6036, Fax: 22 99 6103

**Poland**

Semac Co., Ltd.
PL-05-075 Wesola k/Warszaway, ul. Wspolna 1A
Phone: 022-6131847, Fax: 022-613-3028

**Portugal**

SMC España (Sucursal Portugal), S.A.
Rua de Engº Ferreira Dias 452, 4100 Porto
Phone: 02-610-89-22, Fax: 02-610-89-36

**Romania**

SMC Romania srl
Vasile Stroescu 19, Sector 2, Bucharest
Phone: 01-210-1354, Fax: 01-210-1680

**Russia**

SMC Pneumatik LLC
Centrako Business Centre 103,
Bolshoy Prospect V.O., 199106 St. Petersburg
Phone: 812-1195131, Fax: 812-1195129

**Slovakia**

SMC Slovakia s.r.o.
Pribinova ul. C. 25, 819 02 Bratislava
Phone: 0-563 3548, Fax: 07-563 3551

**Slovenia**

SMC Slovenia d.o.o.
Grajski trg 15, 8360 Zuzemberk
Phone: 068-88 044 Fax: 068-88 041

**Spain**

SMC España, S.A.
Zuazobidea 14, Pol. Ind. Jundiz,
E-01015 Vitoria
Phone: 945-184 100, Fax: 945-184 124

**Sweden**

SMC Pneumatics Sweden A.B.
Ekhagsvägen 29-31, S-14105 Huddinge
Phone: 08-603 07 00, Fax: 08-603 07 10

**Switzerland**

SMC Pneumatik AG
Dorfstrasse 7, CH-8484 Weisslingen
Phone: 052-396-3131, Fax: 052-396-3191

**Turkey**

Entek Pnömatik San. ve Tic Ltd. Sti.
Perpa Tic. Merkezi Kat: 11 No: 1625,
TR-80270 Okmeydanı Istanbul
Phone: 0212-221-1512, Fax: 0212-220-2381

**UK**

SMC Pneumatics (UK) Ltd
Vincent Avenue, Crownhill,
Milton Keynes, MK8 0AN
Phone: 01908-563888 Fax: 01908-561185

OTHER SUBSIDIARIES WORLDWIDE:

ARGENTINA, AUSTRALIA, BOLIVIA, BRASIL, CANADA, CHILE, CHINA, HONG KONG, INDIA, MALAYSIA, MEXICO, NEW ZEALAND, PHILIPPINES, SINGAPORE, SOUTH KOREA, TAIWAN, THAILANDIA, USA, VENEZUELA

For more information, please contact your local SMC Regional Centre

SMC UK Regional Centres**BELFAST**

Tel:01232 778414 Fax:01232 778422
SMC Pneumatics (UK) Ltd
Northern Ireland Regional Centre
Suite 3, Shaftesbury House, Edgewater Road
Belfast
BT3 9JQ

BIRMINGHAM

Tel:01675 467177 Fax:01675 465073
SMC Pneumatics (UK) Ltd
Birmingham Regional Centre
24 The Courtyard, Gorsej Lane, Coleshill
Warwickshire
B46 1JA

BRISTOL

Tel:01179 522155 Fax:01179 522186
SMC Pneumatics (UK) Ltd
Bristol Regional Centre
5 East Gate Office Centre
East Gate Road, Eastville, Bristol
BS5 6XX

SMC UK Distributors**Birmingham**

JAMES LISTER
Tel: 0121 5803800
Fax: 0121 5535951

Blackburn

BLACKBURN PNEUMATIC SYSTEMS LTD
Tel: 01254 682232
Fax: 01254 682224

Bristol

APPLIED AUTOMATION
Tel: 0117 9827769
Fax: 0117 9235522

CRAWLEY

Tel:01293 614094 Fax:01293 614135
SMC Pneumatics (UK) Ltd
Crawley Regional Centre
9 Pelham Court, Pelham Place, Broadfield
Crawley
RH11 9AZ

CUMBERNAULD

Tel:01236 781133 Fax:01236 780611
SMC Pneumatics (UK) Ltd
Scottish Regional Centre
1 Carradale Crescent,
Broadwood Business Park, Cumbernauld
Glasgow
G69 9LE

DROITWICH

Tel: 01905 774544 Fax: 01905 797343
SMC Pneumatics (UK) Ltd
Droitwich Regional Centre
Hampton Park, Hampton Lovett
Droitwich, Worcestershire
WR9 0NX

Bury St Edmunds

PNEUMATIC LINES
Tel: 01284 706239
Fax: 01284 761218

Cardiff

WALES FLUID POWER
Tel: 01222 494551
Fax: 01222 481955

IPSWICH

Tel:01473 240040 Fax:01473 747707
SMC Pneumatics (UK) Ltd
Ipswich Regional Centre
Unit 6 & 7, Alpha Business Park
16-18 Whitehouse Road, Ipswich, Suffolk
IP1 5LT

MANCHESTER

Tel:0161 876 7371 Fax:0161 876 7372
SMC Pneumatics (UK) Ltd
Manchester Regional Centre
3 Modwen Road, Waters Edge Business Park
Ordsall Lane, Salford, Manchester
M5 3EZ

MILTON KEYNES

Tel: 01908 265247 Fax: 01908 262705
SMC Pneumatics (UK) Ltd
Vincent Avenue, Crownhill, Milton Keynes
MK8 0AN

East Grinstead

AUTARKY AUTOMATION
Tel: 01342 311388
Fax: 01342 323733

Newton Aycliffe

ONCAD AUTOMATION
Tel: 01325 311599
Fax: 01325 307562

NEWCASTLE

Tel:0191 487 2040 Fax:0191 487 2041
SMC Pneumatics (UK) Ltd
Newcastle Regional Centre
Unit B6, Marquis Court, Marquis Way
Team Valley Trading Estate, Gateshead
Tyne & Wear
NE11 0RU

POOLE

Tel:01202 732233 Fax:01202 737743
SMC Pneumatics (UK) Ltd
Poole Regional Centre
Unit 4, Acorn Business Centre, Ling Road
Poole, Dorset
BH12 4NZ

SHEFFIELD

Tel: 01909 565504 Fax: 01909 569717
SMC Pneumatics (UK) Ltd
Sheffield Regional Centre
Unit 4, North Anston Business Park
Houghton Road, North Anston, Sheffield
S31 7JJ

Plymouth

APPLIED AUTOMATION
Tel: 01752 343300
Fax: 01752 341161

Redditch

MULTI-PNEUMATICS
Tel: 01527 544544
Fax: 01527 544296