



Series VC
Direct Operated 2 Port Solenoid Valve for Steam

Series VCS



Multipurpose Valve for Steam Direct Operated 2 Port Solenoid Valve for Steam

Series VCS

Improved durability

(nearly twice the life of the previous series)

The internal resistance of moving parts has been reduced through the use of a unique magnetic material. Service life, durability and corrosion resistance have been increased.

High flow rate:
Cv factor 0.16 to 2.1

Smaller size:

Single valve volume reduced by 15% (Class 3)

Manifold length reduced by 18% (Class 3: 5 stations) (SMC comparison)

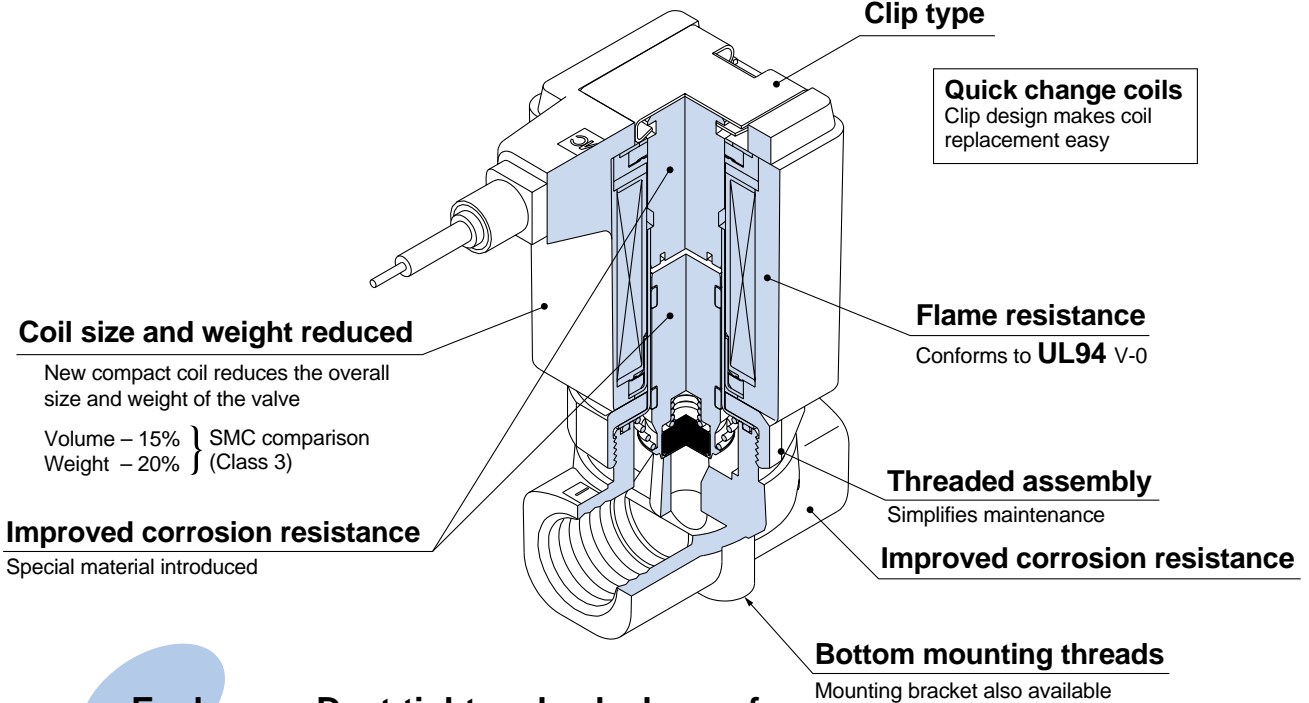

Enclosure: Dust-tight and splash proof
(equivalent to IP65)

Wiring specifications (Class H coil)

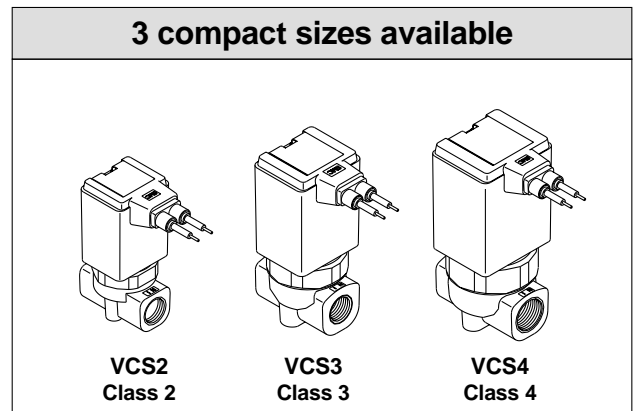
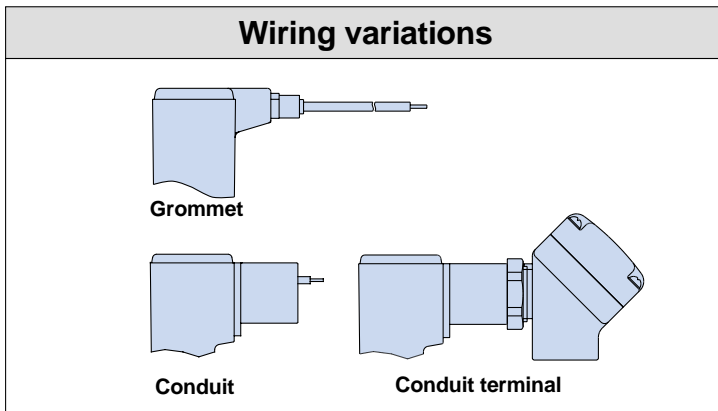

Series VC

Direct Operated 2 Port Solenoid Valve for Steam Series VCS

How to Order Valves (Single Type)

VC S 2 1 - 1 G 2 02

For steam

When no symbol is shown for "Material and insulation type"

- Body material: Brass
- Seal material: PTFE
- Coil insulation: Class H

Series

2	Class 2
3	Class 3
4	Class 4

Valve type

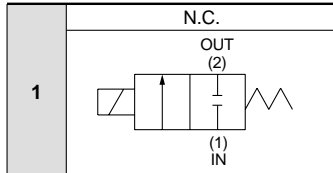

Voltage

1	100VAC
2	200VAC
3	110VAC
4	220VAC
36	230VAC

* Consult SMC regarding other voltages.

Electrical entry

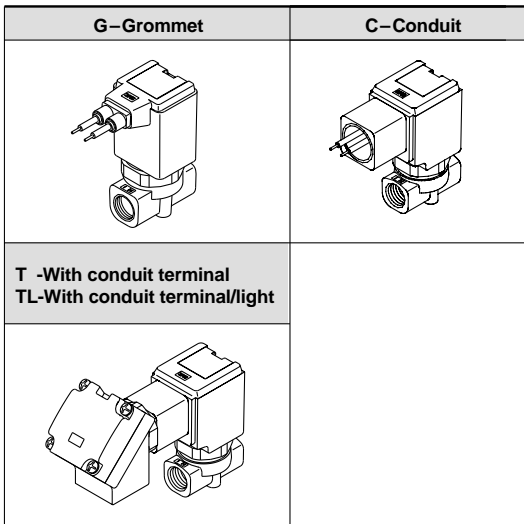

Option

Nil	None
F	Foot type bracket

Material and insulation type

Symbol	Body material	Seal material	Coil insulation
Nil	Brass	PTFE	Class H
D		FKM	
R	Stainless steel	PTFE	
N		FKM	

Thread type

Nil	Rc
N	NPT
F	G

Port size

Symbol	Port size	Class 2	Class 3	Class 4
01	1/8 (6A)	○	—	—
02	1/4 (8A)	○	○	○
03	3/8 (10A)	—	○	○
04	1/2 (15A)	—	○	○
06	3/4 (20A)	—	—	○

Orifice size

Symbol	Orifice diameter	Class 2	Class 3	Class 4
2	ø2mm	○	—	—
3	ø3mm	○	○	○
4	ø4mm	○	○	○
5	ø5mm	○	○	○
7	ø7mm	—	○	○
10	ø10mm	—	○	○

* Refer to the table below for orifice and port size combinations.

Orifice and port size combinations

Class	Port size	Orifice size					
		ø2	ø3	ø4	ø5	ø7	ø10 ^{Note 1)}
2	1/8 (6A)	●	●	●	●	—	—
	1/4 (8A)	●	●	●	●	—	—
3	1/4 (8A)	—	●	●	●	●	—
	3/8 (10A)	—	●	●	●	●	●
4	1/2 (15A)	—	—	—	—	—	●
	1/4 (8A)	—	●	●	●	●	—
	3/8 (10A)	—	●	●	●	●	●
	1/2 (15A)	—	—	—	—	—	●
	3/4 (20A)	—	—	—	—	—	●

Note 1) ø10 is available with seal material FKM only.

Standard Specifications



Valve specifications	Valve construction		Direct operated poppet
	Fluid		Steam (184°C or less)
	Withstand pressure MPa		5.0
	Body material		Brass, Stainless steel
	Seal material		PTFE (FKM)
	Ambient temperature °C		-20 to 100
	Fluid temperature °C		184 or less (PTFE), 120 or less (FKM) <small>Note 1)</small>
	Enclosure		Dust proof, Splash proof (equivalent to IP65)
	Environment		Location without corrosive or explosive gases
	Valve leakage cm ³ /min		300 (PTFE), 0.1 (FKM) with air
	Mounting orientation		Unrestricted
Vibration/Impact resistance m/s ² <small>Note 2)</small>		30/150 or less	
Coil Specifications	Rated voltage		100VAC, 110VAC, 200VAC, 220VAC, 230VAC (50/60Hz)
	Allowable voltage fluctuation		±10% of rated voltage
	Coil insulation type		Class H
	Power consumption W 50/60Hz		VCS2: 4.9/4.1, VCS3: 7.7/6.6, VCS4: 10.5/9.3
	Apparent power VA 50/60Hz	Inrush	VCS2: 22/19, VCS3: 36/30, VCS4: 45/37
Holding		VCS2: 10/8, VCS3: 15/13, VCS4: 19/16	

Note 1) In case of low pressure steam at a temperature of 120°C or less, use FKM for the seal material.

Note 2) Vibration resistance ... Conditions when tested with one sweep of 10 to 300Hz in the axial direction and at a right angle to the armature, in both energized and deenergized states

Impact resistance Conditions when tested with a drop tester in the axial direction and at a right angle to the armature, one time each in energized and deenergized states

Characteristic Specifications

Model	Class	<small>Note 1)</small> Port size	<small>Note 1)</small> Orifice size mm	Maximum operating pressure differential MPa	Effective area mm ² (Cv factor)	Max. operating pressure MPa	Weight kg
VCS2	2	1/8 (6A) 1/4 (8A)	ø2	1.0	2.8 (0.16)	1.0 (10)	1/8: 0.21 1/4: 0.24
			ø3	0.8	5.9 (0.33)		
			ø4	0.5	9.2 (0.51)		
			ø5	0.3	11.7 (0.65)		
VCS3	3	1/4 (8A) 3/8 (10A) 1/2 (15A)	ø3	1.0	6.3 (0.35)	1.0 (10)	1/4: 0.42 3/8: 0.40 1/2: 0.49
			ø4	0.8	9.7 (0.54)		
			ø5	0.5	14.4 (0.8)		
			ø7	0.2	24.8 (1.38)		
VCS4	4	1/4 (8A) 3/8 (10A) 1/2 (15A) 3/4 (20A)	ø3	1.0	6.3 (0.35)	1.0 (10)	1/4: 0.58 3/8: 0.55 1/2: 0.62 3/4: 0.78
			ø4	1.0	10.8 (0.60)		
			ø5	0.7	15.3 (0.85)		
			ø7	0.3	24.8 (1.38)		
			ø10	0.12	37.8 (2.10)		

Note 1) Refer to model selection on page 7 regarding port size and orifice size combinations.

Construction

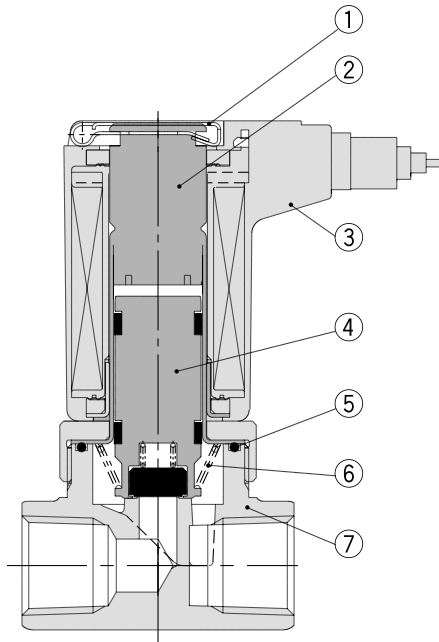

Parts list

No.	Description	Material
		Standard
1	Clip	Stainless steel
2	Tube assembly	Stainless steel, Cu
3	Coil assembly	Class H
4	Armature assembly	Stainless steel, PTFE (FKM)
5	Seal	PTFE (FKM)
6	Return spring	Stainless steel
7	Body	Brass

Dimensions/Bracket

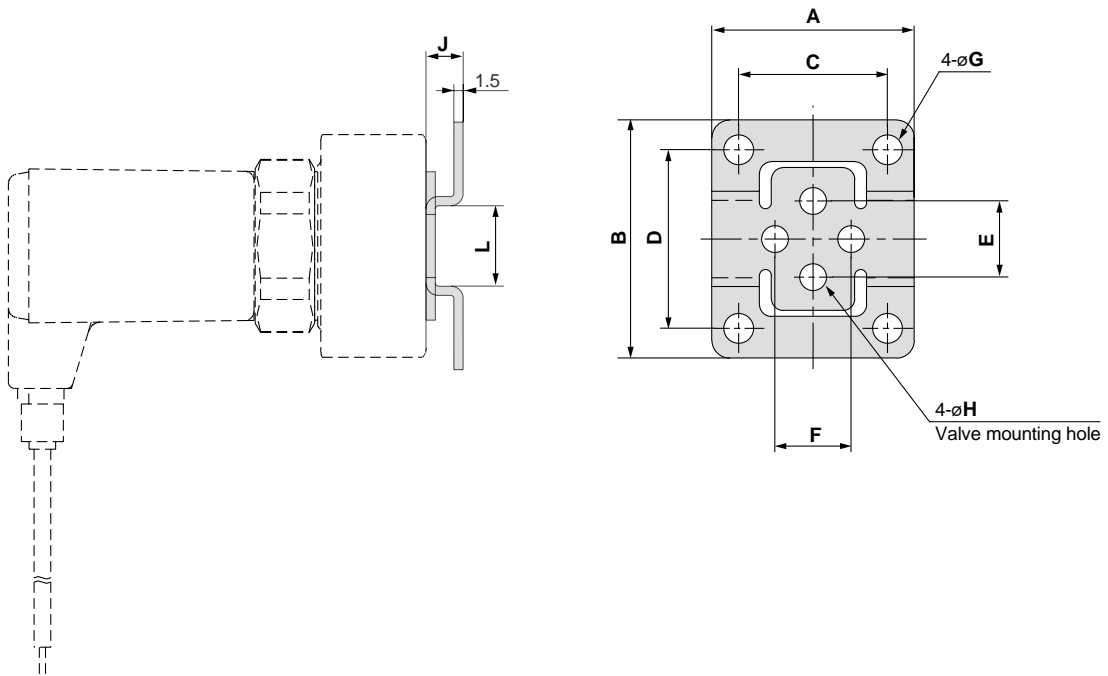

Bracket mounting dimensions

Valve model	Port size	Bracket part no.	A	B	C	D	E	F	G	H	J	L
VCS21	1/8, 1/4	VCS20-12-01	34	40	25	30	12.8	12.8	5	4.5	6	13
VCS31	1/4, 3/8	VCS30-12-02	42	52	30	40	19	19	6	5.5	7	19
	1/2	VCS30-12-04	48	56	36	44	23	23	6	5.5	7	23
VCS41	1/4, 3/8	VCS40-12-02	42	52	30	40	23	23	6	5.5	7	19
	1/2	VCS30-12-04	48	56	36	44	23	23	6	5.5	7	23
	3/4	VCS40-12-06	56	65	44	53	28.2	28.2	6	5.5	7	26

* Bracket material: Stainless steel

Series VCS

Dimensions

Grommet: G

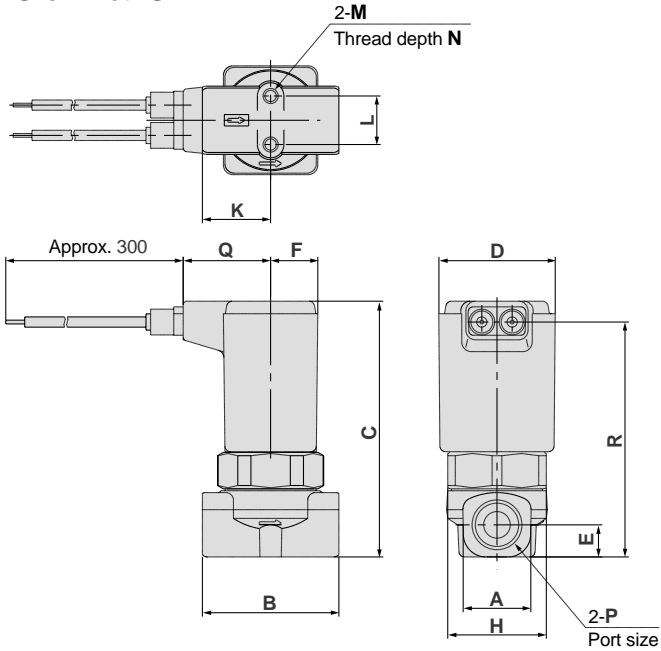

Conduit: C

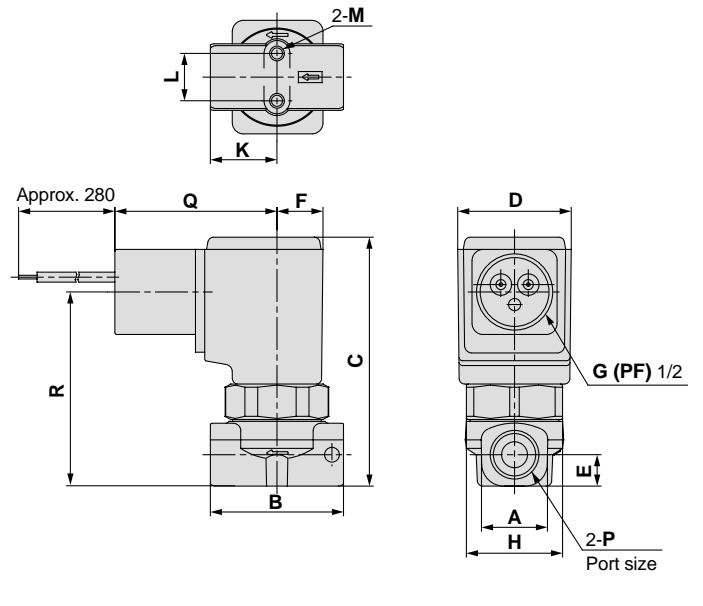

Conduit terminal: T

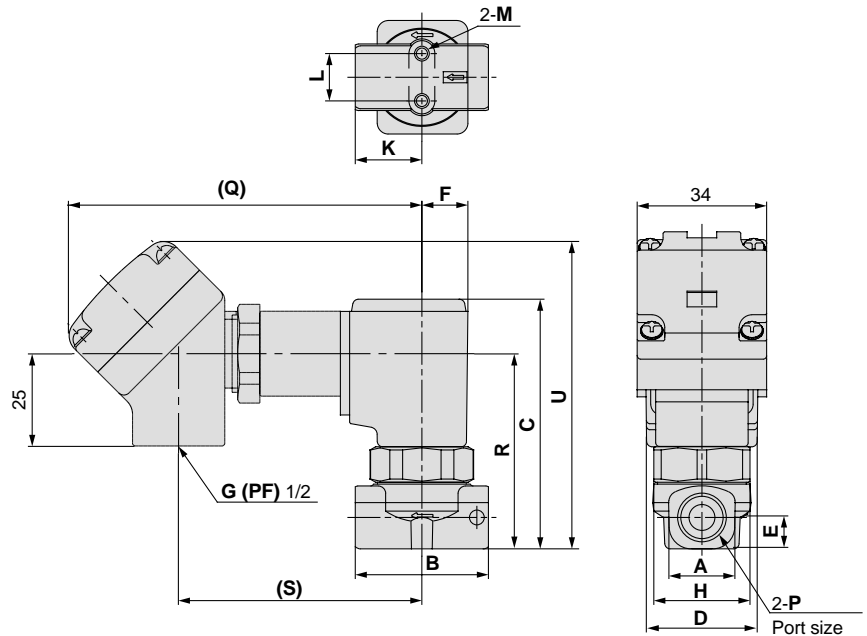

N.C.

(mm)

Model	P Port size	A	B	C	D	E	F	H	K	L	M	N	Electrical entry							
													Grommet: G		Conduit: C		Conduit terminal: T			
													Q	R	Q	R	Q	R	S	U
VCS21	1/8	13.5	28	64	31	6.5	12.5	28	14	12.8	M4	4.5	22	59	44	50	99	50	66	83
	1/4	18	36	67.5	31	8.5	12.5	28	18	12.8	M4	6	22	62	44	53	99	53	66	86
VCS31	1/4, 3/8	22	40	81.5	36.5	11	15	32	20	19	M5	8	24	76	46	66.5	101	66.5	68	99
	1/2	30	50	86	36.5	13.5	15	32	25	23	M5	8	24	80	46	71	101	71	68	104
VCS41	1/4, 3/8	22	45	90	41	11	17	36	22.5	23	M5	8	26	84	48	74.5	103	74.5	70	107
	1/2	30	50	94	41	13.5	17	36	25	23	M5	8	26	88	48	78.5	103	78.5	70	111.5
	3/4	35	60	102	41	17.5	17	36	30	28.2	M5	8	26	96	48	86.5	103	86.5	70	119

How to Order Manifolds

VV2C S 2-D 02 01

For steam
Manifold material: Brass

Series

2	Class 2
3	Class 3
4	Class 4

Material

Symbol	Body material	Seal material
D	Brass	FKM
H	Stainless steel	FKM

Stations

02	2 stations
:	:
10	10 stations

* Refer to the L dimensions on page 6 regarding the maximum number of stations.

Thread type

Symbol	Thread type
Nil	Rc
N	NPT
F	G

OUT port size

Symbol	Port size
01	1/8 (6A)
02	1/4 (8A)

* All IN ports are 3/8.



How to Order Manifold Assemblies (Example)

Enter the valve and option models to be mounted under the manifold base part number.

<Example>
VV2CS2-D05011 set Manifold part no.
* VCS23-1G-2 5 sets Valve part no.
(Stations 1 to 5)

"*" is the symbol for mounting.
Add a "*" in front of the part numbers for solenoid valves, etc., to be mounted.

Enter together in order, counting from station 1 on the D side.

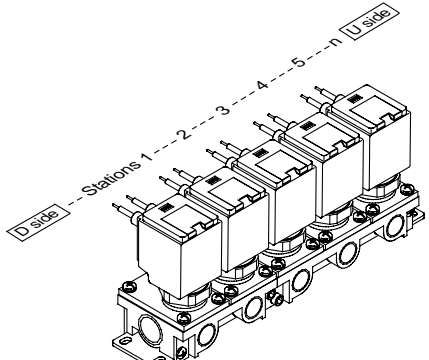

How to Order Valves (for Manifold)

VC S 2 3-1 G 2

For steam
• Body material: Brass
• Seal material: PTFE
• Coil insulation: Class H

Series

2	Class 2
3	Class 3
4	Class 4

Valve type

3	N.C. for manifold
---	-------------------

Voltage

1	100VAC
2	200VAC
3	110VAC
4	220VAC
36	230VAC

* Consult SMC regarding other voltages.

Material and insulation type

Symbol	Body material	Seal material	Coil insulation
Nil	Brass	PTFE	Class H
D		FKM	
R	Stainless steel	PTFE	
N		FKM	

Note) High corrosion resistant specification used for armature material.

Orifice size

Symbol	Orifice size	Class 2	Class 3	Class 4
2	ø2mm	○	—	—
3	ø3mm	○	○	○
4	ø4mm	○	○	○
5	ø5mm	○	○	○
7	ø7mm	—	○	○

Electrical entry

G	Grommet
C	Conduit
T	Conduit terminal
TL	With conduit terminal/light

Manifold Options

Blanking plate assembly

VVCS 2 0 - 3A

Series

2	Class 2
3	Class 3
4	Class 4

Material and insulation type

Symbol	Plate material	Seal material
NII	Brass	PTFE
D		FKM
R	Stainless steel	PTFE
N		FKM

This is used by mounting it on the manifold block when a valve is removed for maintenance or when the mounting of an additional valve is planned, etc.

JIS symbol



Series VCS

Dimensions

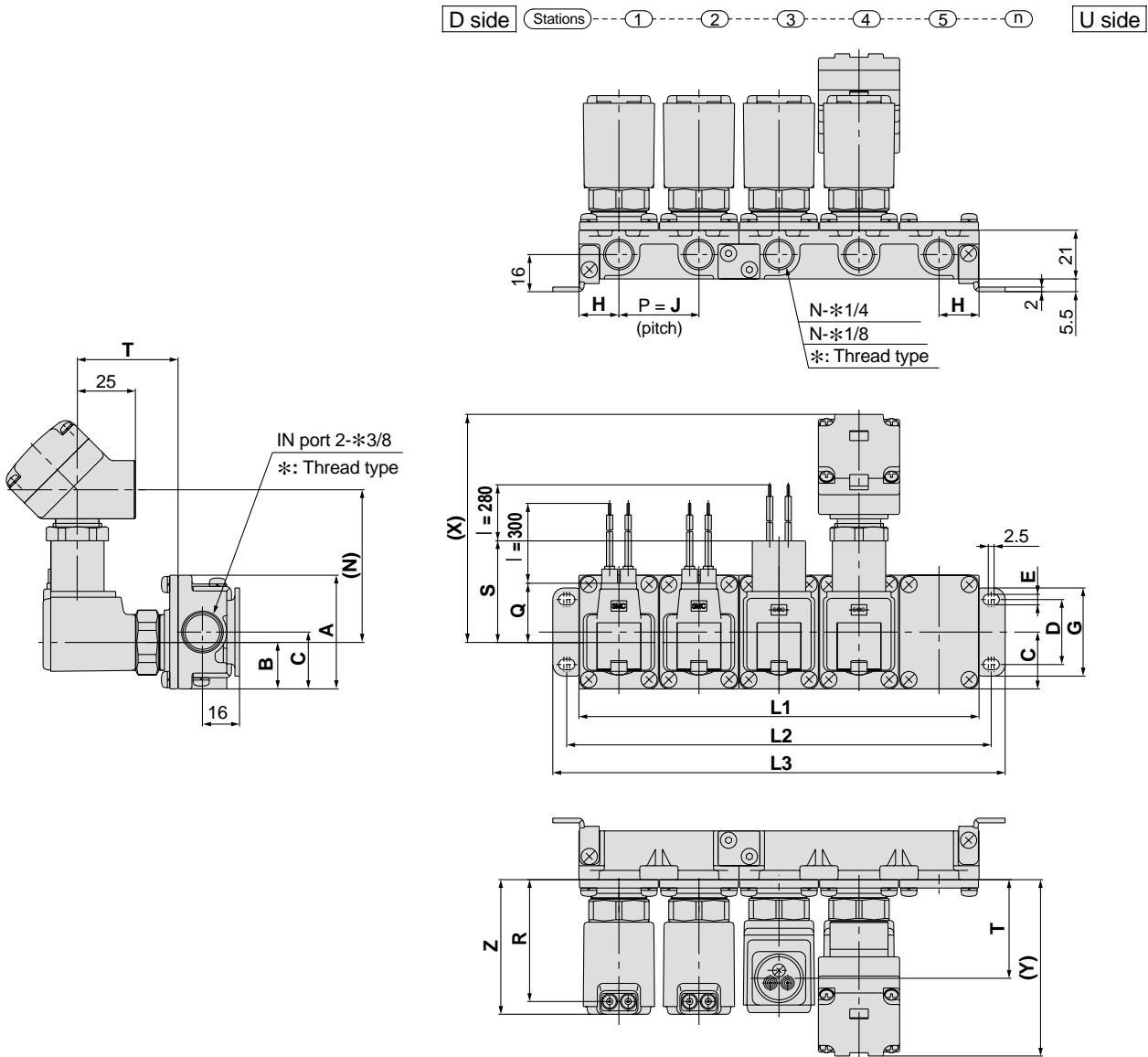

L dimensions

(mm)

Model	Dimensions	n (stations)								
		2	3	4	5	6	7	8	9	10
VV2CS2	L1	69	103.5	138	172.5	207	241.5	276	310.5	345
	L2	81	115.5	150	184.5	219	253.5	288	322.5	357
	L3	93	127.5	162	196.5	231	265.5	300	334.5	369
VV2CS3	L1	77	115.5	154	192.5	231	269.5	308	346.5	385
	L2	89	127.5	166	204.5	243	281.5	320	358.5	397
	L3	101	139.5	178	216.5	255	293.5	332	370.5	409
VV2CS4	L1	83	124.5	166	207.5	249	290.5	332	373.5	415
	L2	95	136.5	178	219.5	261	302.5	344	385.5	427
	L3	107	148.5	190	231.5	273	314.5	356	397.5	439
Manifold composition		2 stns. x 1	3 stns. x 1	2 stns. x 2	2 stns. + 3 stns.	3 stns. x 2	2 stns. x 2 + 3 stns.	2 stns. + 3 stns. x 2	3 stns. x 3	2 stns. x 2 + 3 stns. x 2

Note) Manifold bases are composed by connecting 2 station and 3 station bases.

Dimensions

(mm)

Model	A	B	C	D	E	G	H	J	Z	Electrical entry						
										Grommet: G		Conduit: C		Conduit terminal: T		
										Q	R	S	T	N	X	Y
VV2CS2	49	20	24.5	28	4.5	38	17.3	34.5	56	22	50.5	44	41.5	66	99	77
VV2CS3	57	25.5	28.5	30	5.5	42	19.3	38.5	66	24	60	45.5	51	68	101	86.5
VV2CS4	57	25.5	28.5	30	5.5	42	20.8	41.5	74	26	68	47.5	58.5	70	103	94

Series VCS Model Selection

VCS (for steam) 2 port solenoid valve

Model	Material		Class	Port size	Orifice size					
	Body	Seal			ø2	ø3	ø4	ø5	ø7	ø10 ^{Note 1)}
VCS (for steam) 2 port solenoid valve	Brass (stainless steel)	PTFE (FKM)	2	1/8 (6A)	●	●	●	●	-	-
				1/4 (8A)	●	●	●	●	-	-
			3	1/4 (8A)	-	●	●	●	●	-
				3/8 (10A)	-	●	●	●	●	●
				1/2 (15A)	-	-	-	-	-	●
			4	1/4 (8A)	-	●	●	●	●	-
				3/8 (10A)	-	●	●	●	●	●
				1/2 (15A)	-	-	-	-	-	●
				3/4 (20A)	-	-	-	-	-	●

Note 1) ø10 is available with seal material FKM only.

For saturated steam

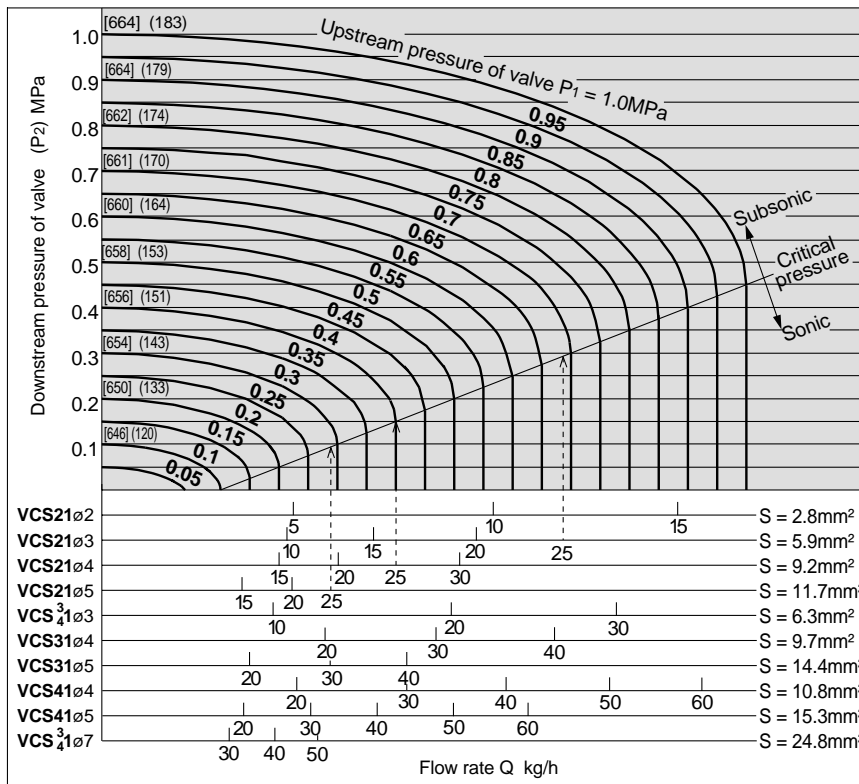

Figures inside [] indicate the saturated steam holding heat (kcal/kg).

Figures inside () indicate the saturation temperature (°C).

Viewing the graph

The sonic range pressure to generate a flow rate of 25kg/h

for orifice ø3 (VCS21) is P1 approx. 0.68MPa

for orifice ø4 (VCS21) is P1 approx. 0.40MPa

for orifice ø5 (VCS21) is P1 approx. 0.29MPa

The holding heat differs somewhat depending

on the pressure P1, but at 25kg/h it is

approximately 16000kcal/h.

How to find the flow rate for saturated steam

1. For subsonic range

Where $P_1 + 0.1013 = (1 \text{ to } 2) (P_2 + 0.1013)$

- Formula based on Cv factor

$$Q = 197.8 \cdot C_v \cdot \sqrt{\Delta P (P_2 + 0.1013)} \dots \text{kg/h}$$

- Formula based on effective area

$$Q = 11.0 \cdot S \cdot \sqrt{\Delta P (P_2 + 0.1013)} \dots \text{kg/h}$$

2. For sonic range

Where $P_1 = 0.1013 \geq 2 (P_2 + 0.1013)$

- Formula based on Cv factor

$$Q = 98.9 \cdot C_v \cdot (P_1 + 0.1013) \dots \text{kg/h}$$

- Formula based on effective area

$$Q = 5.5 \cdot S \cdot (P_1 + 0.1013) \dots \text{kg/h}$$

Explanation of Terminology

Pressure Terminology

1. Maximum operating pressure differential

This indicates the maximum pressure differential (upstream and downstream pressure differential) which can be allowed for operation with the valve closed or open. When the downstream pressure is 0MPa, this becomes the maximum operating pressure.

2. Maximum operating pressure

This indicates the limit of pressure that can be applied inside the pipelines. (line pressure)

(The pressure differential of the solenoid valve unit must be no more than the maximum operating pressure differential.)

3. Withstand pressure

The pressure which must be withstood without a drop in performance after returning to the operating pressure range. (the value under the prescribed conditions)

Electrical Terminology

1. Surge voltage

A high voltage which is momentarily generated in the shut-off unit by shutting off the power.

Other

1. Materials

PTFE: Tetrafluoroethylene resin – Trade names: Teflon®, Polyflon®, etc.

FKM: Fluoro rubber – Trade names: Viton®, Dai-el®, etc.





Series VCS

Safety Instructions

These safety instructions are intended to prevent a hazardous situation and/or equipment damage. These instructions indicate the level of potential hazard by a label of "**Caution**", "**Warning**" or "**Danger**". To ensure safety, be sure to observe ISO 4414 Note 1) and other safety practices.

 **Caution** : Operator error could result in injury or equipment damage.

 **Warning** : Operator error could result in serious injury or loss of life.

 **Danger** : In extreme conditions, there is a possible result of serious injury or loss of life.

Note 1) ISO 4414 : Pneumatic fluid power – Recommendations for the application of equipment to transmission and control systems

Warning

1. The compatibility of equipment is the responsibility of the person who designs the system or decides its specifications.

Since the products specified here are used in various operating conditions, their compatibility for the specific system must be based on specifications or after analysis and/or tests to meet your specific requirements. Be particularly careful in determining the compatibility of the fluid to be used.

2. Only trained personnel should operate machinery and equipment.

The fluid can be dangerous if handled incorrectly. Assembly, handling or repair of systems should be performed by trained and experienced operators.

3. Do not service machinery/equipment or attempt to remove components until safety is confirmed.

1. Inspection and maintenance of machinery/equipment should only be performed after confirmation of safe locked-out control positions and measures to prevent danger from the fluid.
2. When equipment is to be removed, confirm the safety process as mentioned above, release fluid pressure and be certain there is no danger from fluid leakage or fluid remaining in the system.
3. Restart machinery carefully, confirming that safety measures are being implemented.

4. Contact SMC if the product is to be used in any of the following conditions:

1. Conditions and environments beyond the given specifications, or if product is used outdoors.
2. With fluids whose application causes concern due to the type of fluid or additives, etc.
3. An application which has the possibility of having negative effects on people, property, or animals, requiring special safety analysis.



Series VCS

2 Port Solenoid Valve for Fluid Control/Precautions 1

Be sure to read before handling.

Precautions on Design

⚠ Warning

1. Cannot be used as an emergency shutoff valve, etc.

The valves presented in this catalogue are not designed for safety applications such as an emergency shutoff valve. If the valves are used in this type of system, other reliable safety assurance measures should also be adopted.

2. Extended periods of continuous energization

Consult SMC if valves will be continuously energized for extended periods of time.

3. Liquid seals

In cases with a flowing liquid, provide a by-pass valve in the system to prevent the liquid from entering the liquid seal circuit.

4. This solenoid valve cannot be used for explosion proof applications.

5. Maintenance space

The installation should allow sufficient space for maintenance activities (removal of valve, etc.).

Selection

⚠ Warning

1. Confirm the specifications.

Give careful consideration to operating conditions such as the application, fluid and environment, and use within the operating ranges specified in this catalog.

2. Fluid temperature

Operate within the prescribed fluid temperature range. The temperature range changes depending on the seal material, coil insulation and the type of power supply, etc.

3. Fluid quality

The use of fluid which contains foreign matter can cause problems such as malfunction and seal failure by promoting wear of the valve seat and core, and by sticking to the sliding parts of the armature, etc. Install a suitable filter (strainer) immediately upstream from the valve. As a general rule, use 80 to 100 mesh.

Water supplied to boilers includes substances such as calcium and magnesium which generate hard scale and sludge. Since this scale and sludge can cause valve malfunction, install water softening equipment, and a steam filter (strainer) directly upstream from the valve to remove these substances.

⚠ Caution

1. Leakage voltage

Particularly when using a resistor in parallel with a switching element and using a C-R element (surge voltage suppressor) to protect the switching element, take note that leakage current will flow through the resistor and C-R element, etc., creating a danger that the valve may not shut OFF.

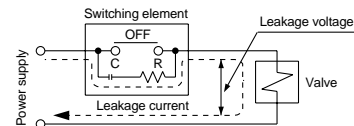

AC coil

10% or less of rated voltage

2. Low temperature operation

1. The valve can be used at ambient temperatures as low as -20°C , but take measures to prevent freezing or solidification of impurities, etc.
2. When used in cold areas, adopt freeze prevention measures such as draining the water from pipelines. If warmed with a heater, etc., avoid the coil unit. Also, implement warming or other freeze prevention measures for the body.



Series VCS

2 Port Solenoid Valve for Fluid Control/Precautions 2

Be sure to read before handling.

Mounting

⚠ Warning

1. If air leakage increases or equipment does not operate properly, stop operation.

After mounting is completed, confirm that it has been done correctly by performing a suitable function test.

2. Do not apply external force to the coil section.

When tightening is performed, apply a wrench or other tool to the outside of the piping connection parts.

3. Do not warm the coil assembly with a heat insulator, etc.

Use tape and heaters, etc., for freeze prevention on the piping and body only. They can cause burn out of the coil.

4. Secure with brackets, except in the case of steel piping and copper fittings.

5. Avoid sources of vibration, or adjust the arm from the body to the minimum length so that resonance will not occur.

6. Instruction manual

Mount the product after reading the manual carefully and understanding its contents. Also keep the manual where it can be referred to as necessary.

7. Painting and coating

Warnings or specifications printed or pasted on the product should not be erased, removed or covered up.

Piping

⚠ Caution

1. Preparation before piping

Before piping is connected, it should be thoroughly blown out with air (flushing) or washed to remove chips, cutting oil and other debris from inside the pipe.

2. Wrapping of pipe tape

When connecting pipes and fittings, etc., be sure that chips from the pipe threads and sealing material do not get inside the valve.

Furthermore, when pipe tape is used, leave 1.5 to 2 thread ridges exposed at the end of the threads.

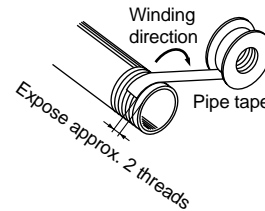

3. Avoid connection of ground lines to piping, as this may cause electric corrosion of the system.

4. Always tighten threads with the proper tightening torque.

When screwing fittings into valves, tighten with the proper tightening torque shown below.

Tightening torque for piping

Connection threads	Proper tightening torque N·m
Rc 1/8	7 to 9
Rc 1/4	12 to 14
Rc 3/8	22 to 24
Rc 1/2	28 to 30
Rc 3/4	28 to 30

5. Connection of piping to products

When connecting piping to a product, refer to its instruction manual to avoid mistakes regarding the supply port, etc.

6. Steam generated in a boiler contains a large amount of drainage.

Be sure to operate with a drain trap installed.

7. When connecting piping to a valve, be sure to tighten while holding the valve with a wrench or other tool.



Series VCS

2 Port Solenoid Valve for Fluid Control/Precautions 3

Be sure to read before handling.

Wiring

⚠ Caution

- As a rule, use electrical wire of 0.5 to 1.25mm² for wiring. Furthermore, do not allow excessive force to be applied to the lines.
- Use electrical circuits which do not generate chattering in their contacts.
- Use voltage which is within $\pm 10\%$ of the rated voltage. In cases with a DC power supply where importance is placed on responsiveness, stay within $\pm 5\%$ of the rated value. The voltage drop is the value in the lead wire section connecting the coil.
- When surge from the solenoid affects the electrical circuitry, install a surge absorber, etc., in parallel with the solenoid.

Electrical Connections

⚠ Caution

Grommet/Conduit

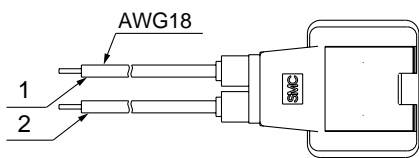

Rated voltage	Lead wire color	
	1	2
100VAC	Blue	Blue
200VAC	Red	Red
Other AC	Gray	Gray

Conduit terminal

In the case of the conduit terminal, make connections according to the marks shown below.

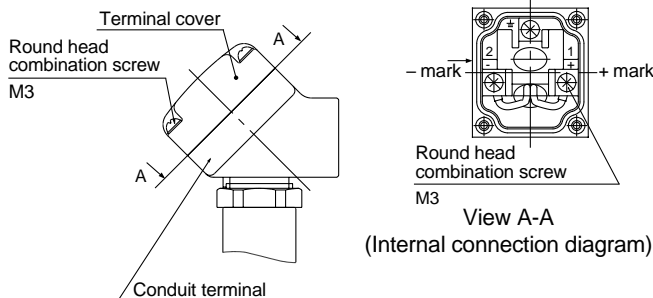

* There is polarity only when equipped with light.

Electrical Circuits

⚠ Caution

Grommet/Conduit

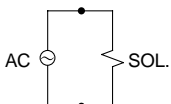

Conduit terminal

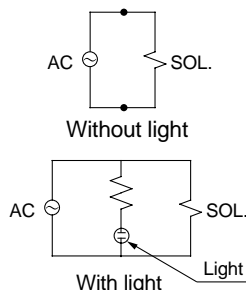

Operating Environment

⚠ Warning

- Do not use valves in atmospheres of corrosive gases, chemicals, salt water, water, or where there is direct contact with same.
- Do not use in explosive atmospheres.
- Do not use in locations subject to vibration or impact.
- Do not use in locations where radiated heat will be received from nearby heat sources.
- Employ suitable protective measures in locations where there is contact with water droplets, oil or welding spatter, etc.

Maintenance

⚠ Warning

- Perform maintenance in accordance with the procedures in the instruction manual.

Improper handling can cause damage or malfunction of machinery and equipment, etc. In addition, perform maintenance inspections once every six months to ensure optimum performance.

2. Removing the product

The valve will reach a high temperature when used with high temperature fluids such as steam. Confirm that the valve temperature has dropped sufficiently before performing work. If touched inadvertently, there is a danger of being burned.

Removal

- Shut off the fluid supply and release the fluid pressure in the system.
- Shut off the power supply.
- Demount the product.

3. Low frequency operation

Switch valves at least once every 30 days to prevent malfunction.

⚠ Caution

1. Filters and strainers

- Be careful regarding clogging of filters and strainers.
- Replace filter elements after one year of use, or earlier if the pressure drop reaches 0.1MPa.
- Clean strainers when the pressure drop reaches 0.1MPa.

2. Storage

In case of long term storage after use with steam, first thoroughly remove all moisture to prevent rust and deterioration of rubber materials, etc.

Operating Precautions

⚠ Warning

- Valves will reach high temperatures from high temperature fluids such as steam. Use caution, as there is a danger of being burned if a valve is touched directly.
- Valves may reach high temperatures when continuously energized. Use caution, as there is a danger of being burned if a valve is touched directly.



Series VCS Specific Product Precautions

Be sure to read before handling.

Refer to pages 9 through 12 for safety instructions and precautions regarding 2 port solenoid valve for fluid control.

Replacing the Solenoid Coil

Caution

The valve will reach high temperatures from high temperature fluids such as steam. Confirm that the valve has cooled sufficiently before performing work. If touched inadvertently, there is a danger of being burned.

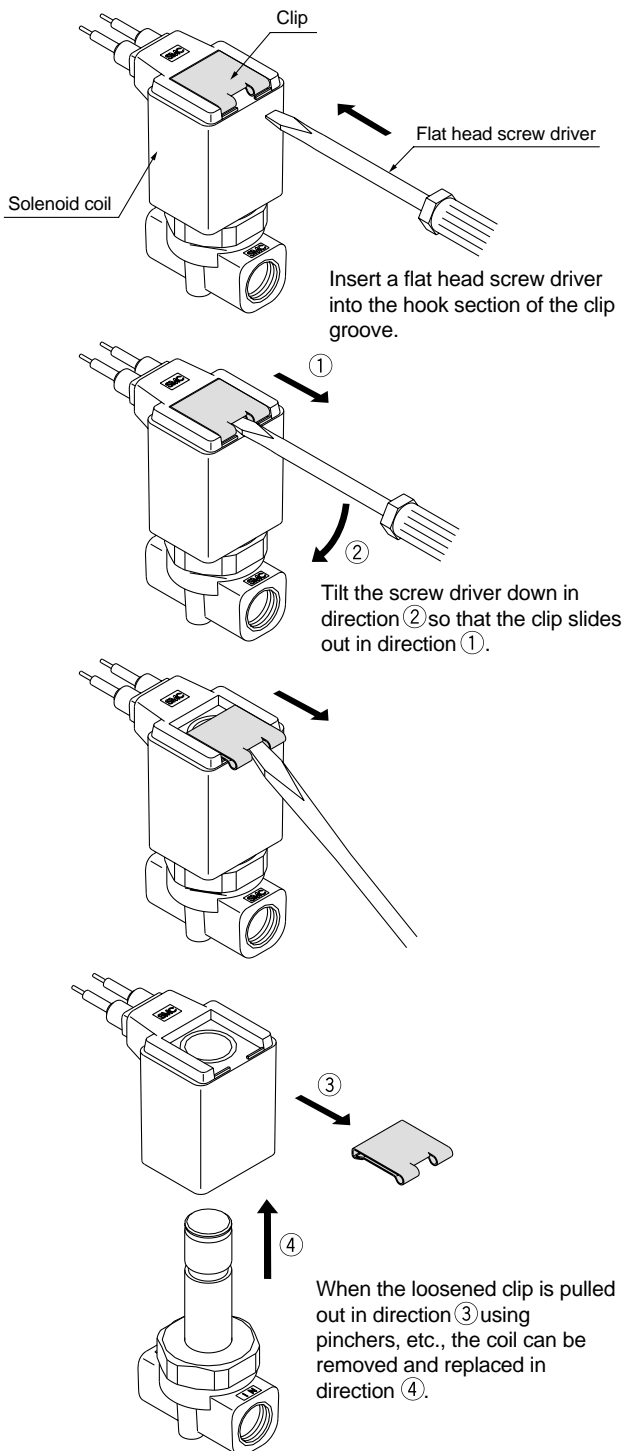

After replacing the coil, the clip is reinstalled by pushing it back in the direction opposite to its removal.

Replacement Parts

Solenoid coil part numbers

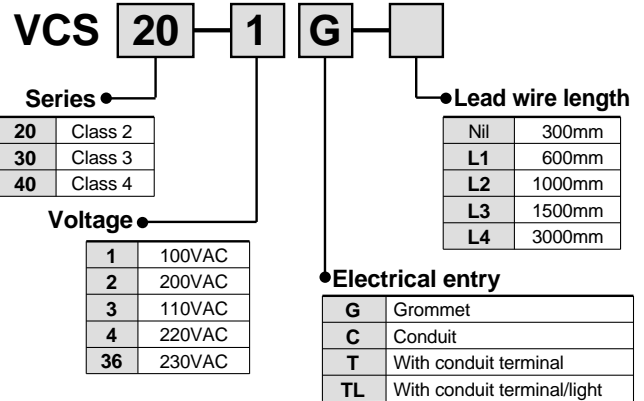

Clip part numbers

AZ-T-VCS

How to Order Valves → Page 1 Valve model
Page 5 Valve model

Note) Indicate the valve model, as a label will be attached to the clip.

Seal part numbers

Valve

For VCS20

OR-1860-120- P

P: PTFE
F: FKM

For VCS30

OR-2380-130- P

P: PTFE
F: FKM

For VCS40

OR-2600-180- P

P: PTFE
F: FKM

Manifold

For VCS20

OR-1400-178- P

P: PTFE
F: FKM

OR-2670-178- P

P: PTFE
F: FKM

For VCS30, 40

OR-1717-178- P

P: PTFE
F: FKM

OR-3305-178- P

P: PTFE
F: FKM

When external leakage occurs after disassembling a valve, replace the above seals.

**Austria**

SMC Pneumatik GmbH (Austria).
Girakstrasse 8, A-2100 Korneuburg
Phone: 02262-62280, Fax: 02262-62285

**Belgium**

SMC Pneumatics N.V./S.A.
Nijverheidsstraat 20, B-2160 Wommelgem
Phone: 03-355-1464, Fax: 03-355-1466

**Czech**

SMC Czech.s.r.o.
Kodanska 46, CZ-100 10 Prague 10
Phone: 02-67154 790, Fax: 02-67154 793

**Denmark**

SMC Pneumatik A/S
Jens Juuls vej 32, DK-8260 Viby J
Phone: 45-70252900, Fax: 45-70252901

**Estonia**

Teknoma Eesti AS
Mustamäe tee 5, EE-0006 Tallinn, Estonia
Phone: 259530, Fax: 259531

**Finland**

SMC Pneumatikka OY
Veneentekijäntie 7, SF-00210 Helsinki
Phone: 09-681021, Fax: 09-6810233

**France**

SMC Pneumatique, S.A.
1, Boulevard de Strasbourg, Parc Gustave Eiffel
Bussy Saint Georges
F-77607 Marne La Vallée Cedex 3
Phone: 01-6476 1000, Fax: 01-6476 1010

**Germany**

SMC Pneumatik GmbH
Boschring 13-15, D-63329 Egelsbach
Phone: 06103-4020, Fax: 06103-402139

**Greece**

S. Parianopoulos S.A.
9, Konstantinoupoleos Street,
GR-11855 Athens
Phone: 01-3426076, Fax: 01-3455578

**Hungary**

SMC Hungary Kft.
Budafoki ut 107-113, 1117 Budapest
Phone: 01-204 4366, Fax: 01-204 4371

**Ireland**

SMC Pneumatics (Ireland) Ltd.
2002 Citywest Business Campus,
Naas Road, Saggart, Co. Dublin
Phone: 01-403 9000, Fax: 01-464 0500

**Italy**

SMC Italia S.p.A
Via Garibaldi 62, I-20061 Carugate, (Milano)
Phone: 02-92711, Fax: 02-92150394

**Latvia**

Ottensten Latvia SIA
Ciekurkalna Prima Gara Linija 11,
LV-1026 Riga, Latvia
Phone: 371-23-68625, Fax: 371-75-56748

**Lithuania**

UAB Ottensten Lietuva
Savanoriu pr.180, LT-2600 Vilnius, Lithuania
Phone/Fax: 370-2651602

**Netherlands**

SMC Pneumatics BV
Postbus 308, 1000 AH Amsterdam
Phone: 020-5318888, Fax: 020-5318880

**Norway**

SMC Pneumatics (Norway) A/S
Wollsvæien 13 C, granfoss Noeringspark
N-134 Lysaker, Norway
Phone: 22 99 6036, Fax: 22 99 6103

**Poland**

Semac Co., Ltd.
PL-05-075 Wesola k/Warszawy, ul. Wspolna 1A
Phone: 022-6131847, Fax: 022-613-3028

**Portugal**

SMC España (Sucursal Portugal), S.A.
Rua de Engº Ferreira Dias 452, 4100 Porto
Phone: 02-610-89-22, Fax: 02-610-89-36

**Romania**

SMC Romania srl
Vasile Stroescu 19, Sector 2, Bucharest
Phone: 01-210-1354, Fax: 01-210-1680

**Russia**

SMC Pneumatik LLC
Centrako Business Centre 103,
Bolshoy Prospect V.O., 199106 St. Petersburg
Phone: 812-1195131, Fax: 812-1195129

**Slovakia**

SMC Slovakia s.r.o.
Pribinova ul. C. 25, 819 02 Bratislava
Phone: 0-563 3548, Fax: 07-563 3551

**Slovenia**

SMC Slovenia d.o.o.
Grajski trg 15, 8360 Zuzemberk
Phone: 068-88 044 Fax: 068-88 041

**Spain**

SMC España, S.A.
Zuazobidea 14, Pol. Ind. Jundiz,
E-01015 Vitoria
Phone: 945-184 100, Fax: 945-184 124

**Sweden**

SMC Pneumatics Sweden A.B.
Ekhagsvägen 29-31, S-14105 Huddinge
Phone: 08-603 07 00, Fax: 08-603 07 10

**Switzerland**

SMC Pneumatik AG
Dorfstrasse 7, CH-8484 Weisslingen
Phone: 052-396-3131, Fax: 052-396-3191

**Turkey**

Entek Pnömatik San. ve Tic Ltd. Sti.
Perpa Tic. Merkezi Kat: 11 No: 1625,
TR-80270 Okmeydanı Istanbul
Phone: 0212-221-1512, Fax: 0212-220-2381

**UK**

SMC Pneumatics (UK) Ltd
Vincent Avenue, Crownhill,
Milton Keynes, MK8 0AN
Phone: 01908-563888 Fax: 01908-561185

OTHER SUBSIDIARIES WORLDWIDE:

ARGENTINA, AUSTRALIA, BOLIVIA, BRASIL, CANADA, CHILE, CHINA, HONG KONG, INDIA, MALAYSIA, MEXICO, NEW ZEALAND, PHILIPPINES, SINGAPORE, SOUTH KOREA, TAIWAN, THAILANDIA, USA, VENEZUELA

For more information, please contact your local SMC Regional Centre

SMC UK Regional Centres**BELFAST**

Tel:02890 778414 Fax:02890 778422
SMC Pneumatics (UK) Ltd
Northern Ireland Regional Centre
Suite 3, Shaftesbury House, Edgewater Road
Belfast
BT3 9JQ

BIRMINGHAM

Tel:01675 467177 Fax:01675 465073
SMC Pneumatics (UK) Ltd
Birmingham Regional Centre
24 The Courtyard, Gorse Lane, Coleshill
Warwickshire
B46 1JA

BRISTOL

Tel:01179 522155 Fax:01179 522186
SMC Pneumatics (UK) Ltd
Bristol Regional Centre
5 East Gate Office Centre
East Gate Road, Eastville, Bristol
BS5 6XX

CRAWLEY

Tel:01293 614094 Fax:01293 614135
SMC Pneumatics (UK) Ltd
Crawley Regional Centre
9 Pelham Court, Pelham Place, Broadfield
Crawley
RH11 9AZ

CUMBERNAULD

Tel:01236 781133 Fax:01236 780611
SMC Pneumatics (UK) Ltd
Scottish Regional Centre
1 Carradale Crescent,
Broadwood Business Park, Cumbernauld
Glasgow
G68 9LE

IPSWICH

Tel:01473 240040 Fax:01473 747707
SMC Pneumatics (UK) Ltd
Ipswich Regional Centre
Unit 6 & 7, Alpha Business Park
16-18 Whitehouse Road, Ipswich, Suffolk
IP1 5LT

MANCHESTER

Tel:0161 876 7371 Fax:0161 876 7372
SMC Pneumatics (UK) Ltd
Manchester Regional Centre
3 Modwen Road, Waters Edge Business Park
Ordsall Lane, Salford, Manchester
M5 3EZ

MILTON KEYNES

Tel: 01908 265247 Fax: 01908 262705
SMC Pneumatics (UK) Ltd
Vincent Avenue, Crownhill, Milton Keynes
MK8 0AN

NEWCASTLE

Tel:0191 487 2040 Fax:0191 487 2041
SMC Pneumatics (UK) Ltd
Newcastle Regional Centre
Unit B6, Marquis Court, Marquis Way
Team Valley Trading Estate, Gateshead
Tyne & Wear
NE11 0RU

POOLE

Tel:01202 732233 Fax:01202 737743
SMC Pneumatics (UK) Ltd
Poole Regional Centre
Unit 4, Acorn Business Centre, Ling Road
Poole, Dorset
BH12 4NZ

SHEFFIELD

Tel: 01909 565504 Fax: 01909 569717
SMC Pneumatics (UK) Ltd
Sheffield Regional Centre
Unit 4, North Anston Business Park
Houghton Road, North Anston, Sheffield
S25 4JJ

SMC UK Distributors**Birmingham**

JAMES LISTER
Tel: 0121 5803800
Fax: 0121 5535951

Blackburn

BLACKBURN PNEUMATIC SYSTEMS LTD
Tel: 01254 682232
Fax: 01254 682224

Bristol

APPLIED AUTOMATION
Tel: 0117 9827769
Fax: 0117 9235522

Bury St Edmunds

PNEUMATIC LINES
Tel: 01284 706239
Fax: 01284 761218

Cardiff

WALES FLUID POWER
Tel: 02920 494551
Fax: 02920 481955

Plymouth

APPLIED AUTOMATION
Tel: 01752 343300
Fax: 01752 341161