

Booster Regulator/Air Tank

New

RoHS

Increase factory air pressure by up to 4 times!
Air-only operation requires no power supply,
reduces heat generation, and
allows easy installation.

NEW

Renewed model with
pressure increase ratio
2 to 4 times (VBA11A)

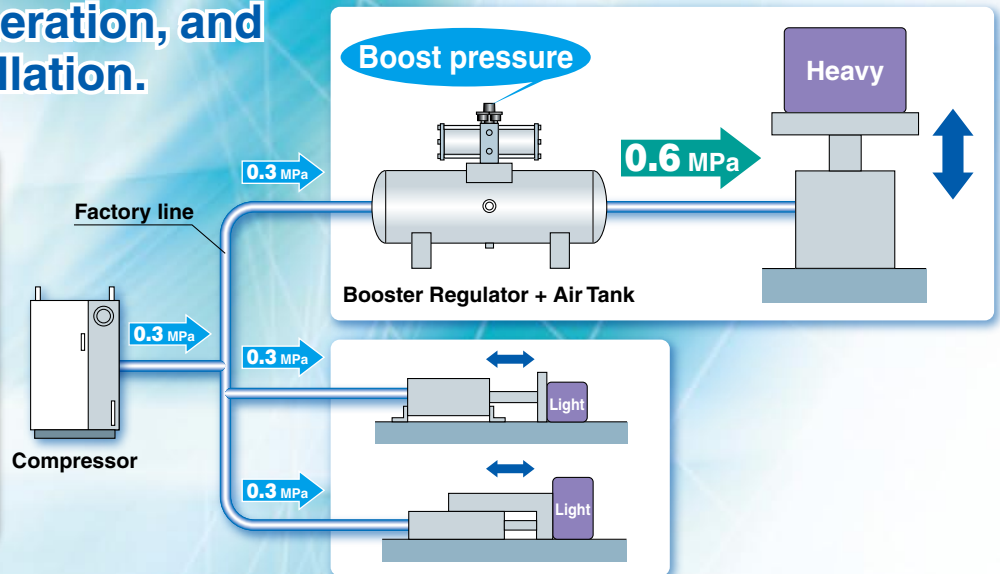

No power supply or wiring needed

There is no need to
install dedicated
electrical wiring.

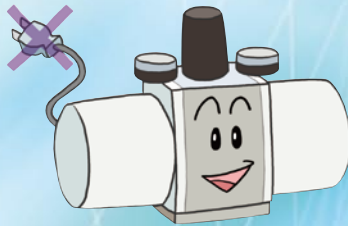

Easy installation

Simply insert the unit
in the air line.
Requires far less
space than installing
the compressor.

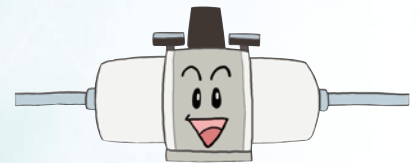

Low heat generation

Very little heat is
generated because
no electricity is
used, and there is
no impact on
cylinders, solenoid
valves, etc.

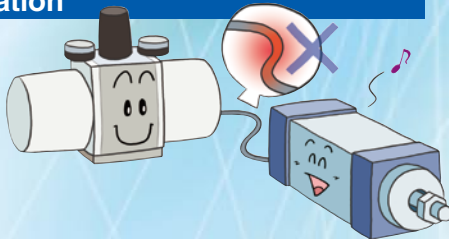

Air-only operation

Operation is safe
because no
electricity is used.

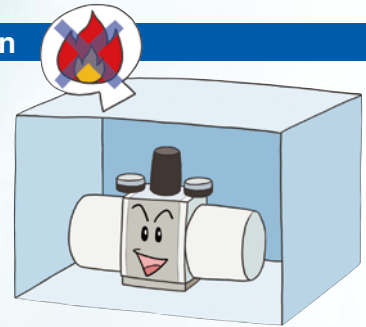

Booster Regulator/Series VBA



Air Tank/Series VBAT

Series VBA/VBAT



CAT.ES11-96D

Booster Regulator Series VBA

Improved service life

Doubled
that of the conventional model

- Floating piston structure (PAT. PEND)
- Grease retaining groove*

* Except VBA10A, 11A

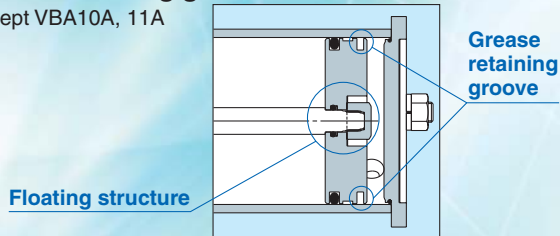

Reduced noise

Reduced by **13 dB (A)**
compared with the conventional model

- Metal noise reduced by a bumper on the impact part of the switch valve
- Exhaust noise reduced by a high-noise reduction silencer

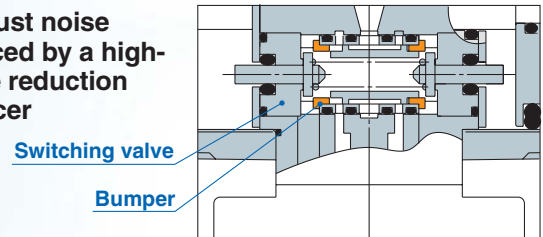

Improved reliability

Built-in mesh filter at IN port

- Prevents operation failure due to foreign matter.

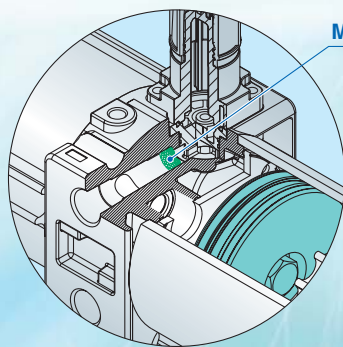

Anti-condensation

Integrated air-feeding tube with the main tube

- Mitigates condensation caused by cooling during exhaust expansion.

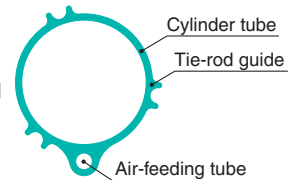

NEW

Elbow silencer added* (Option)

Space saving when installed has been realized.

* Except VBA2□A, 4□A



1/8" gauge ports

- Allows use of standard fittings for remote pressure monitoring, etc.

* Gauge ports changed from 1/16" to 1/8" (VBA1□A, 2□A)

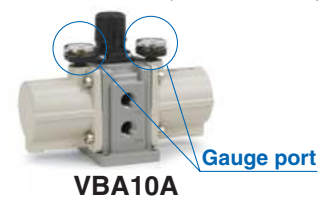

Air-operated type









Max. operating pressure **1.6 MPa**



Fourfold pressure increase type

NEW



Body size	Pressure increase ratio	Twice		2 to 4 times
	Operation	Handle-operated type (Direct operation)		Handle-operated type (Direct operation)
	Set pressure range	0.2 to 1.0 MPa	0.2 to 1.6 MPa (2.0 MPa)	0.2 to 2.0 MPa
1/4"		—	VBA10A-02 (0.2 to 2.0 MPa) 	
3/8"	VBA20A-03 	—	VBA22A-03 	—
1/2"	VBA40A-04 	VBA43A-04 (0.2 to 1.6 MPa) 	VBA42A-04 	—

Air Tank Series VBAT

Perfect fit with a booster regulator

This is an air tank to which a booster regulator can be connected compactly. It can be used alone as a tank. The pressure vessel law is different from country to country, so as an air tank suitable to a country needs to be confirmed.

Extensive product lineup

To meet a variety of usage environment and pressure specifications, models are available in two materials, stainless steel 304 and carbon steel (SS400), and in four sizes ranging from 5 liters to 38 liters.

Model	VBAT05A	VBAT10A	VBAT20A	VBAT38A
Tank capacity (L)	5	10	20	38
Max. operating pressure (MPa)	2.0		1.0	
Material	Carbon steel			

Model	VBAT05S	VBAT10S	VBAT20S	VBAT38S
Tank capacity (L)	5	10	20	38
Max. operating pressure (MPa)	2.0			
Material	Stainless steel			



⚠ Caution

When used as a single unit (not connected with a booster regulator) and pressurized at over 1 MPa at normal temperatures, the air tank falls under the scope of the "High Pressure Gas Safety Act" in Japan.

Booster Regulator Series VBA



Made to Order
(For details, refer to page 11.)

How to Order

VBA **40A** - **04** - **04** - **04**

Body size	Pressure increase ratio: Twice	Pressure increase ratio: 2 to 4 times
10A	1/4", Handle-operated type	
20A	3/8", Handle-operated type	
40A	1/2", Handle-operated type	
22A	3/8", Air-operated type	
42A	1/2", Air-operated type	
43A	1/2", Max. operating pressure 1.6 MPa	
11A	1/4", Handle-operated type	

Semi-standard

Symbol	Semi-standard
Nil	Standard product
Z (Note)	Pressure unit on the product name label and pressure gauge: psi

Note) Thread type: NPT, NPTF
Under the new measurement law, the pressure unit of "psi" on the pressure gauges cannot be used in Japan.

Option

Symbol	Option
Nil	None
G	Pressure gauge
N	Silencer
S	High-noise reduction silencer (Note)
GN	Pressure gauge, Silencer
GS	Pressure gauge, High-noise reduction silencer (Note)
LN	Elbow silencer (Note)
LS	Elbow high-noise reduction silencer (Note)
GLN	Pressure gauge, Elbow silencer (Note)
GLS	Pressure gauge, Elbow high-noise reduction silencer (Note)

Note) Refer to "Combination of Thread Type and Options."

Thread type (Note)

Symbol	Thread type
Nil	Rc
F	G
N	NPT
T	NPTF

Note) Thread types apply to the IN, OUT, and EXH ports of the VBA1□A and to the IN, OUT, EXH, and gauge ports of the VBA2□A and VBA4□A. The gauge ports of the VBA1□A are Rc thread type regardless of the thread type indication.

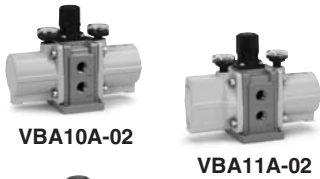
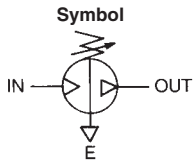

Symbol	Port size	Applicable series
02	1/4	VBA1□A
03	3/8	VBA2□A
04	1/2	VBA4□A

Port size

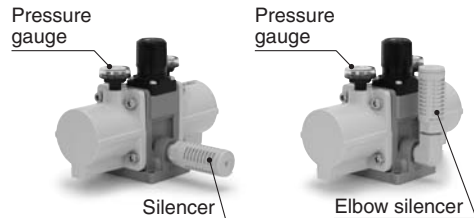

Combination of Thread Type and Options

Body size	Thread type	Option										Semi-standard		
		Nil	G	N	S	GN	GS	LN	LS	GLN	GLS	Nil	-Z	
10A 11A	Nil	●	●	●	●	●	●	●	●	●	●	●	●	—
	F	●	●	●	●	●	●	●	●	●	●	●	●	—
	N	●	●	●	—	●	—	●	—	—	—	●	●	—
	T	●	●	●	—	●	—	●	—	—	—	●	●	—
20A 22A	Nil	●	●	●	●	●	●	—	—	—	—	●	●	—
	F	●	●	●	●	●	●	—	—	—	—	●	●	—
	N	●	●	●	●	●	●	—	—	—	—	●	●	—
	T	●	●	●	●	●	●	—	—	—	—	●	●	—
40A 42A 43A	Nil	●	●	●	●	●	●	—	—	—	—	●	●	—
	F	●	●	●	●	●	●	—	—	—	—	●	●	—
	N	●	●	●	●	●	●	—	—	—	—	●	●	—
	T	●	●	●	●	●	●	—	—	—	—	●	●	—

Air Tank Compatibility Chart

Air tank	Booster regulator		
	VBA1□A	VBA2□A	VBA4□A
VBAT05A	●	—	—
VBAT05S	●	●	—
VBAT10A	—	●	—
VBAT10S	—	●	●
VBAT20A	—	●	●
VBAT20S	—	●	●
VBAT38A	—	●	●
VBAT38S	—	●	●

Standard Specifications

Model	VBA10A-02	VBA20A-03	VBA40A-04	VBA22A-03	VBA42A-04	VBA43A-04	VBA11A-02
Fluid	Compressed air						
Pressure increase ratio	Twice						2 to 4 times
Pressure adjustment mechanism	Handle-operated with relief mechanism ^{Note 1)}			Air-operated		Handle-operated with relief mechanism ^{Note 1)}	
Max. flow rate ^{Note 2)} (L/min (ANR))	230	1000	1900	1000	1900	1600	70
Set pressure range (MPa)	0.2 to 2.0	0.2 to 1.0		0.2 to 1.0		0.2 to 1.6	0.2 to 2.0
Supply pressure range (MPa)	0.1 to 1.0						
Proof pressure (MPa)	3	1.5			2.4		3
Port size (Rc) (IN/OUT/EXH: 3 locations)	1/4	3/8	1/2	3/8	1/2		1/4
Pressure gauge port size (Rc) (IN/OUT: 2 locations)	1/8						
Ambient and fluid temperature (°C)	2 to 50 (No freezing)						
Installation	Horizontal						
Lubrication	Grease (Non-lube)						
Weight (kg)	0.84	3.9	8.6	3.9	8.6	8.6	0.89

Note 1) If the OUT pressure is higher than the set pressure by the handle, excess pressure is exhausted from the back of the handle.

Note 2) Flow rate at IN= OUT= 0.5 MPa. The pressure varies depending on the operating conditions. Refer to "Flow-rate Characteristics" on pages 3 and 4.

Options/Part No.

Pressure Gauge, Silencer (When thread type is Rc or G.)

Model		VBA10A-02	VBA20A-03	VBA40A-04	VBA22A-03	VBA42A-04	VBA43A-04	VBA11A-02
Description		VBA10A-F02	VBA20A-F03	VBA40A-F04	VBA22A-F03	VBA42A-F04	VBA43A-F04	VBA11A-F02
Pressure gauge	G	G27-20-01	G36-10-01		KT-VBA22A-7	G36-10-01	G27-20-01	G27-20-01
Silencer	N	AN200-02	AN300-03	AN400-04	AN300-03	AN400-04	AN400-04	AN200-02
High-noise reduction silencer	S	ANA1-02	ANA1-03	ANA1-04	ANA1-03	ANA1-04	ANA1-04	ANA1-02
Elbow for silencer	L	KT-VBA10A-18	—	—	—	—	—	KT-VBA10A-18

Note 1) In the case of options GN, two pressure gauges and one silencer are included in the same container as accessories.

Note 2) KT-VBA22A-7 is a pressure gauge with fitting. (Please order two units when using with IN and OUT.)

Pressure Gauge, Silencer (When thread type is NPT or NPTF.)

Model		VBA10A-N02*	VBA20A-N03*	VBA40A-N04*	VBA22A-N03*	VBA42A-N04*	VBA43A-N04*	VBA11A-N02*
Description		VBA10A-T02*	VBA20A-T03*	VBA40A-T04*	VBA22A-T03*	VBA42A-T04*	VBA43A-T04*	VBA11A-T02*
		*: when "-Z"	*: when "-Z"	*: when "-Z"	*: when "-Z"	*: when "-Z"	*: when "-Z"	*: when "-Z"
Pressure gauge *: when Nil	G	G27-20-01	G36-10-N01		KT-VBA22A-7N	G36-10-N01	G27-20-N01	G27-20-01
Pressure gauge *: when "Z" ^{Note 4)}		G27-P20-01	G36-P10-N01		KT-VBA22A-8N	G36-P10-N01	G27-P20-N01	G27-P20-01
Silencer	N	AN200-N02	AN300-N03	AN400-N04	AN300-N03	AN400-N04	AN400-N04	AN200-N02
High-noise reduction silencer	S	—	ANA1-N03	ANA1-N04	ANA1-N03	ANA1-N04	ANA1-N04	—
Elbow for silencer	L	KT-VBA10A-18N	—	—	—	—	—	KT-VBA10A-18N

Note 1) In the case of options GN, two pressure gauges and one silencer are included in the same container as accessories.

Note 2) KT-VBA22A-7N, KT-VBA22A-8N are pressure gauges with fittings. (Please order two units when using with IN and OUT.)

Note 3) Under the new measurement law, the pressure unit of "psi" on the pressure gauges cannot be used in Japan.

Note 4) Pressure unit on the pressure gauge: psi

Related Products/Part No.

Mist Separator, Exhaust Cleaner

Model	For VBA10A-02 For VBA11A-02	For VBA20A-03 For VBA22A-03	For VBA40A-04 For VBA42A-04 For VBA43A-04
Mist separator	AM250C-02	AM450C-04, 06	AM550C-06, 10
Exhaust cleaner	AMC310-03	AMC510-06	AMC610-10

Note) Refer to page 12 for air tanks, Best Pneumatics No. 5 for mist separators and Best Pneumatics No. 6 for exhaust cleaners.

Refer to the separate operation manual for the connection method.

Design

⚠ Caution

1. System configuration

- The IN port of the booster regulator has metallic mesh to prevent dust from entering the booster regulator. However, it cannot remove dust continuously or separate drainage. Make sure to install a mist separator (AM series) on the inlet side of the booster regulator.
- The booster regulator has a sliding part inside, and it generates dust. Also, install an air purification device such as an air filter or a mist separator on the outlet side as necessary.
- Connect a lubricator to the outlet side, because the accumulated oil in the booster regulator may result in a malfunction.

2. Exhaust air measures

- Provide a dedicated pipe to release the exhaust air from each booster regulator. If exhaust air is converged into a pipe, the back pressure that is created could cause improper operation.
- Depending on the necessity, install a silencer or an exhaust cleaner on the exhaust port of the booster regulator to reduce the exhaust noise.

3. Maintenance space

- Allow the sufficient space for maintenance and inspection.

Series VBA

VBA10A

Flow-rate Characteristics

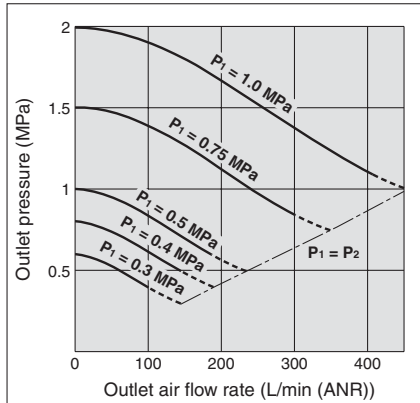

Pressure Characteristics

Inlet pressure: 0.7 MPa (Representative value)
Outlet pressure: 1.0 MPa
Flow rate: 20 L/min (ANR)

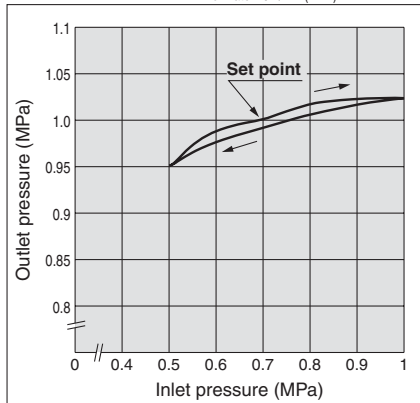

Charge Characteristics

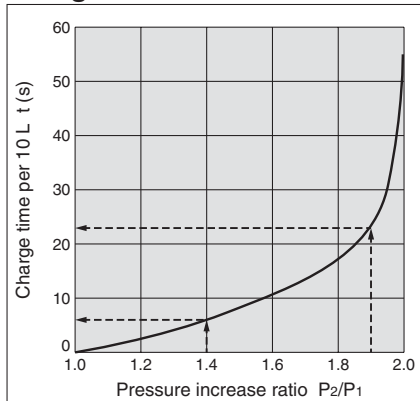

VBA10A

- The time required to charge pressure in the tank from 0.7 MPa to 0.95 MPa at 0.5 MPa supply pressure:

$$\frac{P_2}{P_1} = \frac{0.7}{0.5} = 1.4 \quad \frac{P_2}{P_1} = \frac{0.95}{0.5} = 1.9$$

With the pressure increase ratio from 1.4 to 1.9, the charge time of 23 - 6 = 17 sec. (t) is given by the graph. Then, the charge time (T) for a 10 L tank:

$$T = t \times \frac{V}{10} = 17 \times \frac{10}{10} = 17 \text{ (s).}$$

VBA20A, 22A

Flow-rate Characteristics

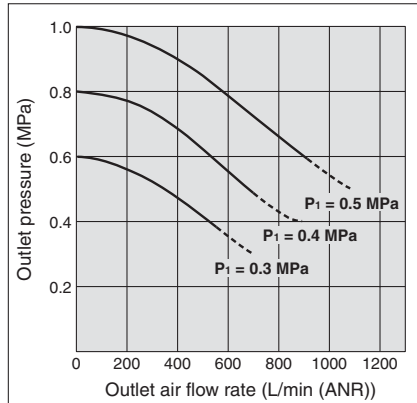

Pressure Characteristics

Inlet pressure: 0.7 MPa (Representative value)
Outlet pressure: 1.0 MPa
Flow rate: 20 L/min (ANR)

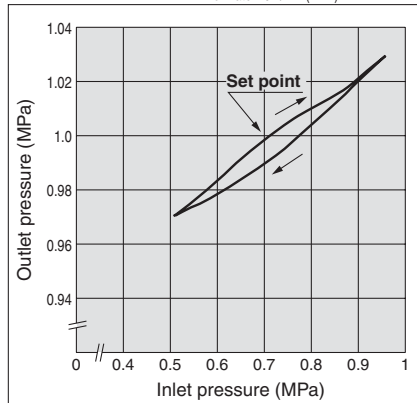

Charge Characteristics

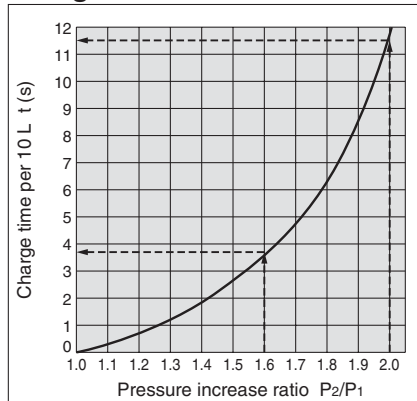

VBA20A, 22A

- The time required to charge pressure in the tank from 0.8 MPa to 1.0 MPa at 0.5 MPa supply pressure:

$$\frac{P_2}{P_1} = \frac{0.8}{0.5} = 1.6 \quad \frac{P_2}{P_1} = \frac{1.0}{0.5} = 2.0$$

With the pressure increase ratio from 1.6 to 2.0, the charge time of 11.5 - 3.8 = 7.7 sec. (t) is given by the graph. Then, the charge time (T) for a 100 L tank:

$$T = t \times \frac{V}{10} = 7.7 \times \frac{100}{10} = 77 \text{ (s).}$$

VBA40A, 42A

Flow-rate Characteristics

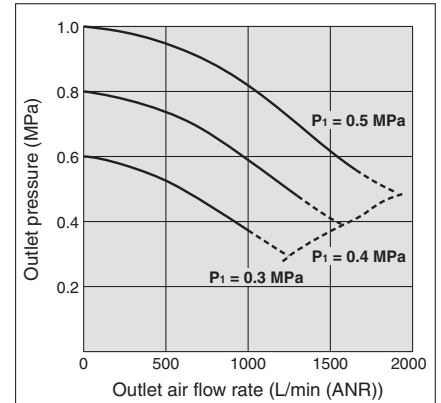

Pressure Characteristics

Inlet pressure: 0.7 MPa (Representative value)
Outlet pressure: 1.0 MPa
Flow rate: 20 L/min (ANR)

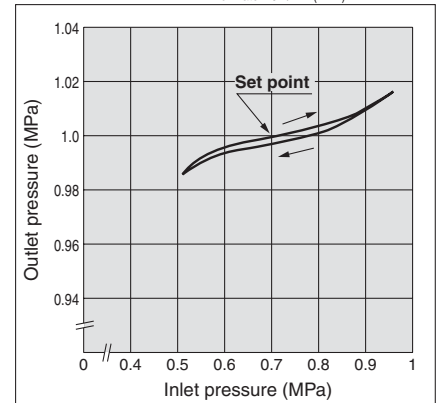

Charge Characteristics

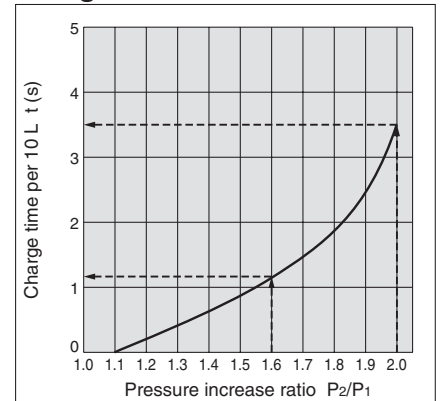

VBA40A, 42A

- The time required to charge pressure in the tank from 0.8 MPa to 1.0 MPa at 0.5 MPa supply pressure:

$$\frac{P_2}{P_1} = \frac{0.8}{0.5} = 1.6 \quad \frac{P_2}{P_1} = \frac{1.0}{0.5} = 2.0$$

With the pressure increase ratio from 1.6 to 2.0, the charge time of 3.5 - 1.1 = 2.4 sec. (t) is given by the graph. Then, the charge time (T) for a 100 L tank:

$$T = t \times \frac{V}{10} = 2.4 \times \frac{100}{10} = 24 \text{ (s).}$$

VBA43A

Flow-rate Characteristics

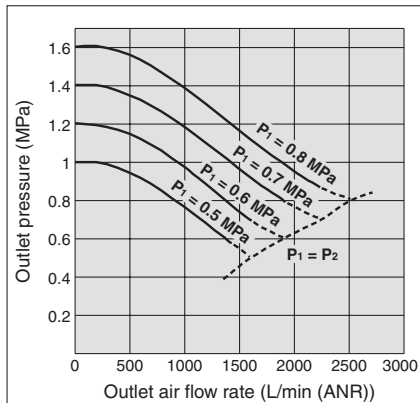

Pressure Characteristics

Inlet pressure: 0.7 MPa (Representative value)
 Outlet pressure: 1.0 MPa
 Flow rate: 20 L/min (ANR)

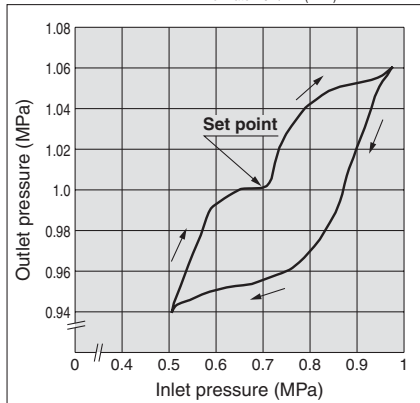

Charge Characteristics

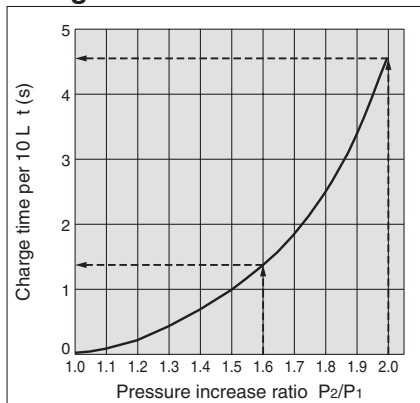

VBA43A

- The time required to charge pressure in the tank from 0.8 MPa to 1.0 MPa at 0.5 MPa supply pressure:

$$\frac{P_2}{P_1} = \frac{0.8}{0.5} = 1.6 \quad \frac{P_2}{P_1} = \frac{1.0}{0.5} = 2.0$$

With the pressure increase ratio from 1.6 to 2.0, the charge time of 4.5 - 1.3 = 3.2 sec. (t) is given by the graph. Then, the charge time (T) for a 100 L tank:

$$T = t \times \frac{V}{10} = 3.2 \times \frac{100}{10} = 32 \text{ (s)}$$

VBA11A

Flow-rate Characteristics

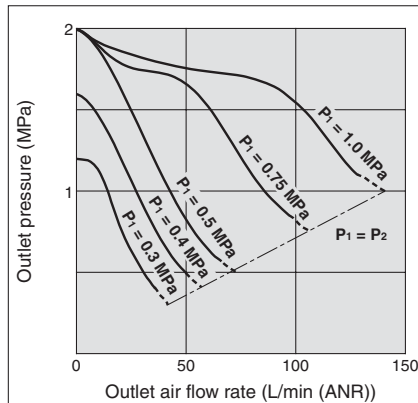

Pressure Characteristics

Inlet pressure: 0.6 MPa (Representative value)
 Outlet pressure: 2.0 MPa
 Flow rate: 10 L/min (ANR)

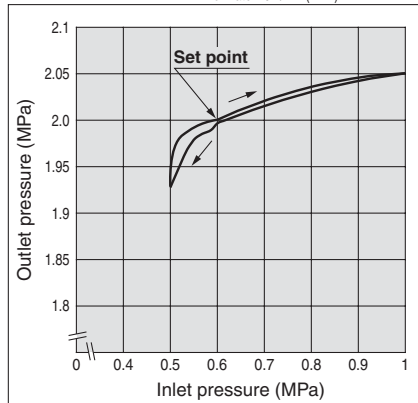

Charge Characteristics

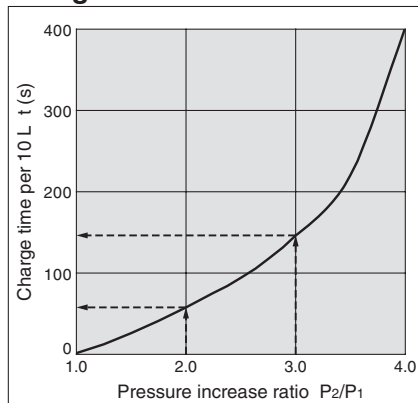

VBA11A

- The time required to charge pressure in the tank from 1.0 MPa to 1.5 MPa at 0.5 MPa supply pressure:

$$\frac{P_2}{P_1} = \frac{1.0}{0.5} = 2.0 \quad \frac{P_2}{P_1} = \frac{1.5}{0.5} = 3.0$$

With the pressure increase ratio from 2.0 to 3.0, the charge time of 147 - 58 = 89 sec. (t) is given by the graph. Then, the charge time (T) for a 10 L tank:

$$T = t \times \frac{V}{10} = 89 \times \frac{10}{10} = 89 \text{ (s)}$$

Pulsation/Pulsation is decreased with a tank.

If the outlet capacity is undersized, pulsation may occur.

VBAT05A

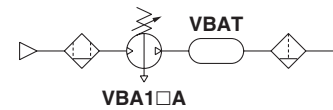
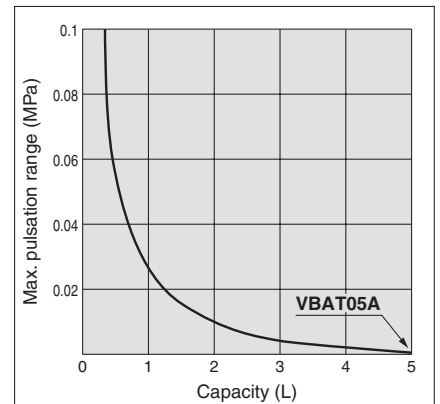

VBAT10A, 20A, 38A

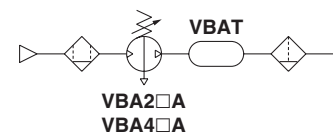
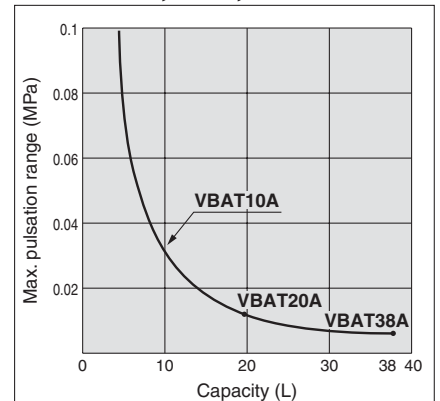

Conditions:
 Inlet pressure: 0.5 MPa
 Outlet set pressure: 1 MPa
 Flow rate: Between 0 and max. flow rate

● Performance of air tank

- Alleviates the pulsation generated on the outlet side.
- When air consumption exceeds air supply during intermittent operation, required air will be accumulated in the tank for use. This does not apply for continuous operation.

Series VBA

Sizing (Sizing can be achieved with the SMC Pneumatic System Energy Saving Program Ver. 3.1) which can be downloaded from the SMC website: <http://www.smcworld.com/>

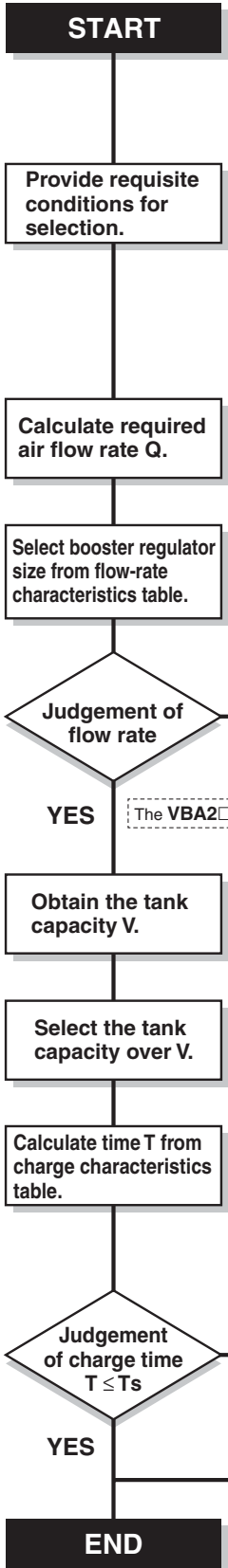
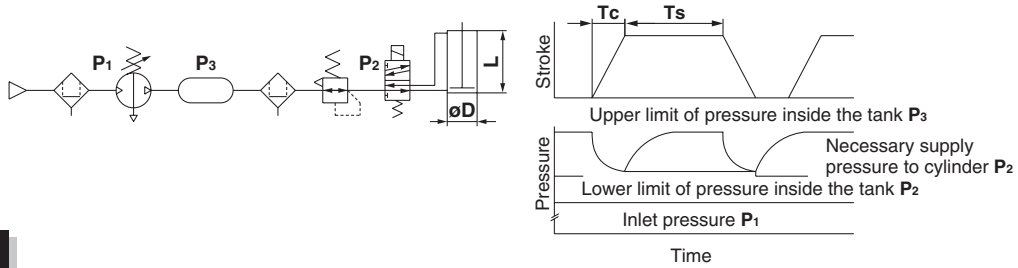

Necessary conditions:
D [mm]: Cylinder bore size
L [mm]: Cylinder stroke
W [mm/s]: Cylinder operating speed
C [pc.]: Number of cylinders
Tc [s]: Cylinder operating time
Ts [s]: Cylinder stop time
P1 [MPa]: Inlet pressure
P2 [MPa] ^{Note 1)}: Necessary supply pressure to cylinder

Example:
 100
 100
 200
 1
 0.5
 30
 0.5
 0.8

Other conditions:
Q [L/min (ANR)]: Required air flow rate
Qb [L/min (ANR)]: Outlet air flow rate of booster regulator
Tc [s]: Cylinder operating time
K: Cylinder double-acting: 2, single-acting: 1
P3 [MPa] ^{Note 2)}: Tank charge pressure
T1 [s]: Time to charge (Time to charge to P2)
T2 [s]: Time to charge (Time to charge to P3)
T [s]: Time to charge (Time to charge from P2 to P3)
Z: Number of booster regulators

Note 1) P2 is the necessary supply pressure to a cylinder, and set the pressure below the lower limit of pressure inside the tank with a regulator. Adjust the pressure taking the maximum operating pressure of equipment in use into consideration.
 Note 2) P3 is the output pressure of the booster regulator, which is also the upper limit of charge pressure to the tank.

$$Q \text{ [L/min (ANR)]} = \frac{\pi \times D^2 \times W}{4 \times 10^6} \times \frac{(P_2 + 0.101)}{0.101} \times 60 \times C$$

$$Q = \frac{\pi \times 100^2 \times 200}{4 \times 10^6} \times \frac{(0.8 + 0.101)}{0.101} \times 60 \times 1 = 841 \text{ [L/min (ANR)]}$$

VBA2□A: Qb = 600 [L/min (ANR)]
VBA4□A: Qb = 1050 [L/min (ANR)]
 Refer to "Flow-rate Characteristics" on pages 3 and 4.

⚠ Caution

- Use the VBA11A (pressure increase ratio 4) with pressure increase ratio 2 to 4. Usage of pressure increase ratio below 2 is preferred for the VBA10A (pressure increase ratio 2). A stable operation and increased life expectancy will result.
- Inlet supply pressure volume is {approximately twice (pressure increase ratio 2), approx. 4 times (pressure increase ratio 4)} the volume of the outlet side. Booster regulator requires the inlet side volume which is the sum of the flow volume running into the outlet side and the volume exhausted from E port (for driving), because air is the power source.

NO: Need no tank **The VBA4□A can supply necessary pressure.**

YES: The VBA2□A cannot obtain necessary pressure.

$$V \text{ [L]} = \frac{(Q - Qb/2) \times (Tc \times K/60)}{(P_3 - P_2) \times 9.9}$$

$$V = \frac{(841 - 600/2) \times (0.5 \times 2/60)}{(1.0 - 0.8) \times 9.9} = 4.6 \text{ [L]}$$

Select the **VBAT10□**, which can be directly connected to the **VBA2□A**.

Refer to "Charge Characteristics" on pages 3 and 4.

$$T \text{ [s]} = \left(\frac{V}{10}\right) \times \frac{T_2 - T_1}{Z}$$

$$T = \left(\frac{4.6}{10}\right) \times \frac{11.5 - 3.8}{1} = 3.5 \text{ [s]}$$

NO: **Extend stop time Ts up to charge time T or more.**

NO: **Increase number of booster regulators (Z) to decrease T.**

NO: **Avoid pulsation. (Max. 0.05 MPa)**

YES: **Select the tank from table below.**

Tank model	Internal capacity	Applicable combination model		
VBAT05□	5 L	VBA1□A	—	—
VBAT10□	10 L	VBA1□A	VBA2□A	—
VBAT20□	20 L	—	VBA2□A	VBA4□A
VBAT38□	38 L	—	VBA2□A	VBA4□A

When running continuously for longer periods of time, confirm the life expectancy. When the life expectancy is shorter than required, select a larger sized booster regulator.

Working Principle

The **IN** air passes through the check valve to **booster chambers A and B**. Meanwhile, air is supplied to **drive chamber B** via the governor and the switching valve. Then, the air pressure from **drive chamber B** and **booster chamber A** are applied to the piston, boosting the air in **booster chamber B**. As the piston travels, the boosted air is pushed via the check valve to the **OUT** side. When the piston reaches to the end, the piston causes the switching valve to switch, so that **drive chamber B** is in the exhaust state and **drive chamber A** is in the supply state respectively. Then, the piston reverses its movement, this time, the pressures from **booster chamber B** and **drive chamber A** boosts the air in **booster chamber A** and sends it to the **OUT** side. The process described above is repeated to continuously supply highly pressurized air from the **IN** to the **OUT** side. The governor establishes the outlet pressure by handle operation and pressure adjustment in the drive chamber by feeding back the outlet pressure.

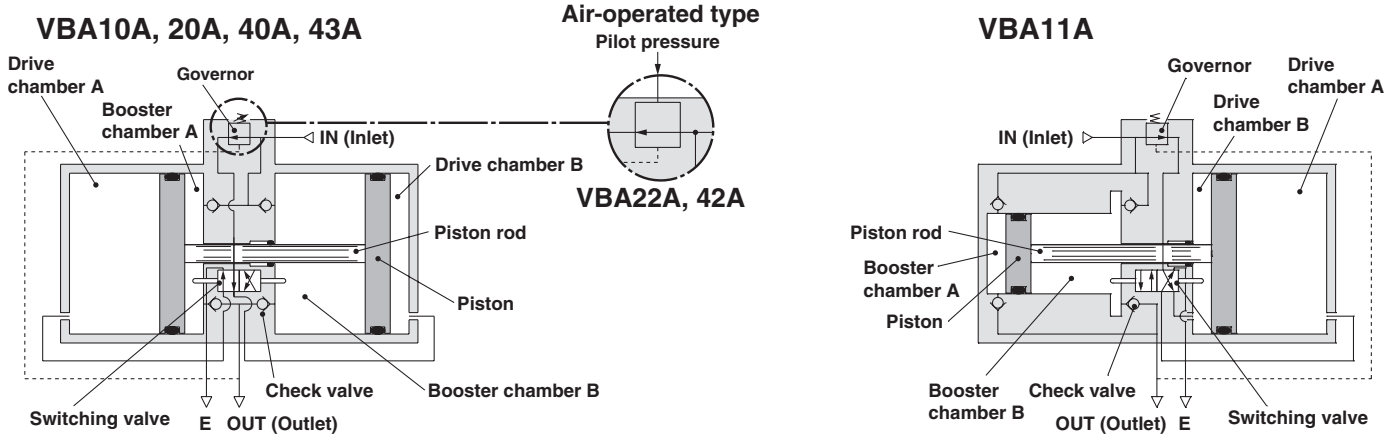

Circuit Example

- When only some of the machines in the plant require high-pressure air, booster regulators can be installed for only the equipment that requires it. This allows the overall system to use low-pressure air while accommodating machines requiring high-pressure air.

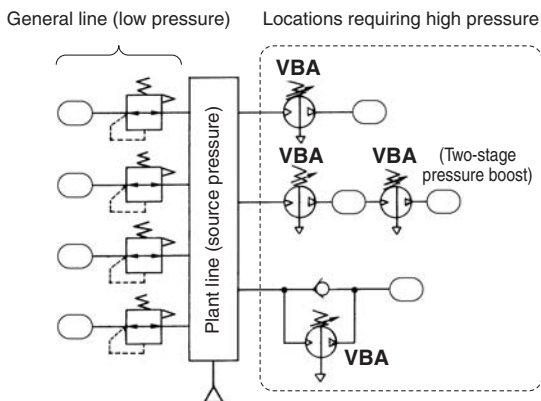

- When charging a tank or the like from a source at atmospheric pressure, a circuit with a check valve can be used to reduce the charge time by allowing air to pass through the check valve up to the inlet pressure.

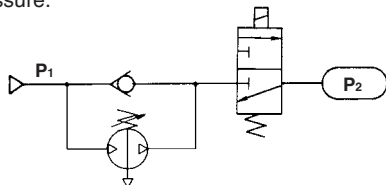

Initially, inlet pressure (P_1) passes through the check valve, fills P_2 , and results in $P_1 = P_2$.

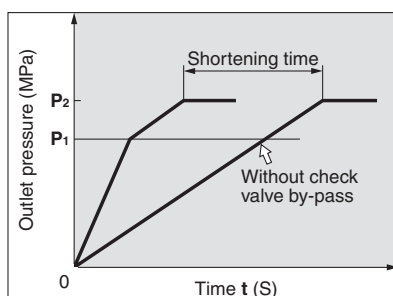

- When the actuator output is insufficient but space limitations prohibit switching to a larger cylinder diameter, a booster regulator can be used to increase the pressure. This makes it possible to boost the output without replacing the actuator.
- When a certain level of output is required but the cylinder size must be kept small so that the driver remains compact.

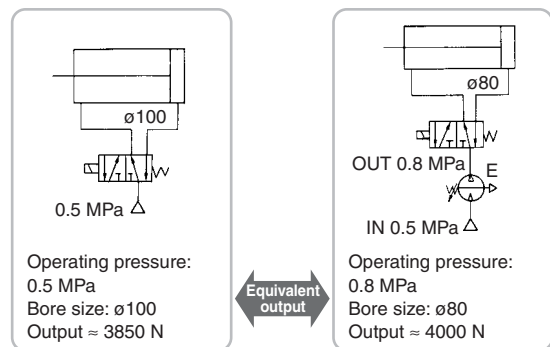

- When only one side of the cylinder is used for work, booster regulators can be installed only on the lines that require them to reduce the overall air consumption volume.

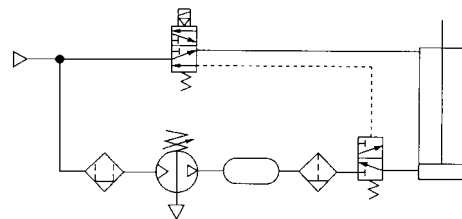

Design

⚠ Warning

1. Warning concerning abnormal outlet pressure

- If there is a likelihood of causing an outlet pressure drop due to unforeseen circumstances such as equipment malfunction, thus leading to a major problem, take safety measures on the system side.
- Because the outlet pressure could exceed its set range if there is a large fluctuation in the inlet pressure, leading to unexpected accidents, take safety measures against abnormal pressures.
- Operate the equipment within its maximum operating pressure and set pressure range.

2. Residual pressure measures

- Connect a 3-port valve to the OUT side of the booster regulator if the residual pressure must be released quickly from the outlet pressure side for maintenance, etc. (Refer to the diagram below.) The residual outlet pressure side cannot be released even if the 3-port valve is connected to the IN side because the check valve in the booster regulator will activate.

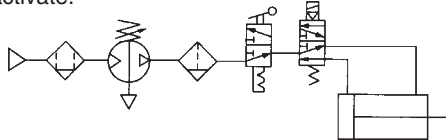

- After operation is finished, release the supply pressure at the inlet. This stops the booster regulator from moving needlessly and prevents operating malfunctions.

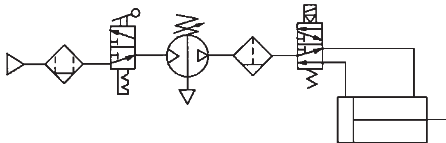

Selection

⚠ Caution

1. Check the specifications.

- Consider the operating conditions and operate this product within the specification range that is described in this catalog.

2. Selection

- Based on the conditions (such as pressure, flow rate, takt time) required for the outlet side of the booster regulator, select the size of the booster regulator in accordance with the selection procedures described in this catalog or model selection program.
- Use the VBA11A (pressure increase ratio 4) with pressure increase ratio 2 to 4. Usage of pressure increase ratio below 2 is preferred for the VBA10A (pressure increase ratio 2). A stable operation and increased life expectancy will result.
- Inlet supply pressure volume is {approximately twice (pressure increase ratio 2), approx. 4 times (pressure increase ratio 4)} the volume of the outlet side. Booster regulator requires the inlet side volume which is the sum of the flow volume running into the outlet side and the volume exhausted from E port (for driving), because air is the power source.
- When running continuously for longer periods of time, confirm the life expectancy. The life expectancy of a booster regulator is dependent upon the operational cycle. Thus, when used for driving cylinders, etc. in the outlet side, life expectancy will be reduced.
- Make sure the outlet pressure is set 0.1 MPa or higher than the inlet pressure. A pressure difference below 0.1 MPa makes the operation unstable and may result in a malfunction.

Mounting

⚠ Caution

1. Transporting

- When transporting this product, hold it lengthwise with both hands. Never hold it by the black handle that protrudes from the center because the handle could become detached from the body, causing the body to fall and leading to injury.

2. Installation

- Install this product so that the silver-colored tie-rods and cover are placed horizontally. If mounted vertically, it may result in a malfunction.
- Because the piston cycle vibration is transferred, use the following mounting bolts (VBA1: M5; VBA2, 4: M10) and tighten them with the specified torque (VBA1: 3 N·m; VBA2, 4: 24 N·m).
- If the transmission of vibration is not preferred, insert an isolating rubber material before installation.
- Mount the pressure gauge with a torque of 7 to 9 N·m.

Piping

⚠ Caution

1. Flushing

- Use an air blower to flush the piping to thoroughly remove any cutting chips, cutting oil, or debris from the piping inside, before connecting them. If they enter the inside of the booster regulator, they could cause the booster regulator to malfunction or its durability could be affected.

2. Piping size

- To bring the booster regulator's ability into full play, make sure to match the piping size to the port size.

Air Supply

⚠ Caution

1. Quality of air source

- Connect a mist separator to the inlet side near the booster regulator. If the quality of the compressed air is not thoroughly controlled, the booster regulator could malfunction (without being able to boost) or its durability could be affected.
- If dry air (atmospheric pressure dew point: -17°C or less) is used, the life expectancy may be shortened because dry air will accelerate evaporation of grease inside.

Operating Environment

⚠ Caution

1. Installation location

- Do not install this product in an area that is exposed to rainwater or direct sunlight.
- Do not install in locations influenced by vibrations. If it must be used in such an area due to unavoidable circumstances, please contact SMC beforehand.

Handling

⚠ Caution

1. Setting the pressure on the handle-operated type

- If air is supplied to the product in the shipped state, the air will be released.
Set the pressure by quickly pulling up on the governor handle, releasing the lock, and rotating the handle in the direction of the arrow (+).
- There is an upper and lower limit for the handle rotation. If over-rotating the handle even after reaching to the limit, the internal parts may be damaged. If the handle suddenly feels heavy while being turned, stop turning the handle.
- Once the setting is completed, push the handle down and lock it.
- To decrease the outlet pressure, after the pressure has been set, rotate the handle in the direction of the arrow (-). The residual air will be released from the area of the handle, due to the relief construction of the governor.
- To reset the pressure, first reduce the pressure so that it is lower than the desired pressure; then, set it to the desired pressure.

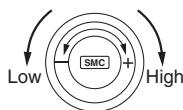

2. Setting the pressure on the air-operated type (VBA22A, 42A)

- Connect the outlet pipe of the pilot regulator for the remote control to the pilot port (P). (Refer to the diagram below.)
- Refer to the graph below for the relationship between the pilot pressure and outlet pressure.
- The AR20 and AW20 are recommended for the pilot regulator.

Pilot regulator

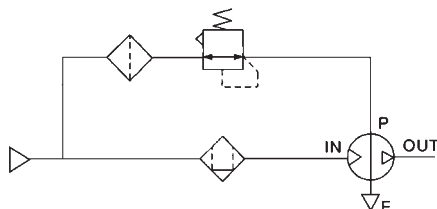

- The outlet pressure is twice the pilot pressure.
- When the inlet pressure is 0.4 MPa:

Pilot pressure
0.2 MPa to 0.4 MPa
Outlet pressure
0.4 MPa to 0.8 MPa

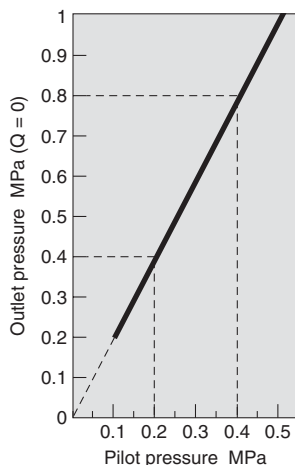

3. Draining

- If this product is used with a large amount of drainage accumulated in the filter, mist separator or tank, the drainage could flow out, leading to equipment malfunction. Therefore, drain the system once a day. If it is equipped with an auto drain, check its operation once a day.

4. Exhaust

- Exhausting time from E port may be longer for a booster regulator which is set to switch in longer hour intervals. This is not an abnormal phenomenon.

5. Maintenance

- Life expectancy varies depending on the quality of air and the operating conditions. Signs that the unit is reaching the end of its service life include the following:
 - Constant bleed from under the handle.
 - Air exhaust noise can be heard from the booster regulator at 10 to 20 second intervals even when there is no air consumption on the outlet side.
Conduct maintenance earlier than scheduled in such cases.
- When maintenance is required, confirm the model and serial number of the booster regulator, and please contact SMC for maintenance kit.
- Conduct maintenance according to the specified maintenance procedure by individuals possessing enough knowledge and experiences in maintaining pneumatic equipment.
- The list of replacement parts and kit number are shown on page 9, and the figure shows the position of the parts.

Series VBA

Construction/Replacement Parts

VBA10A

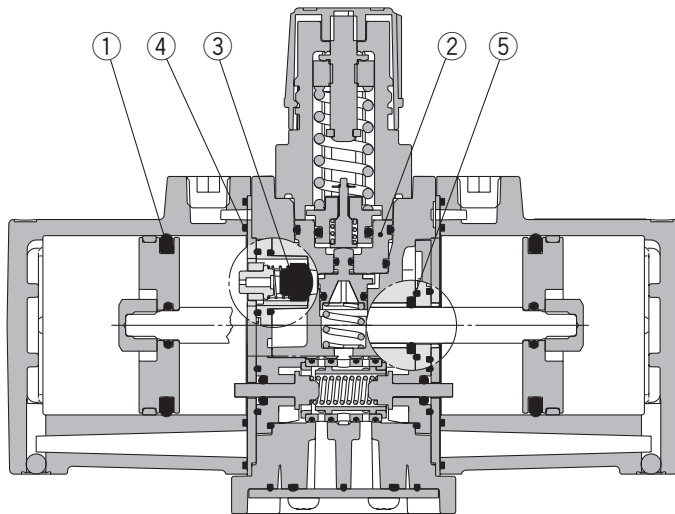

VBA11A

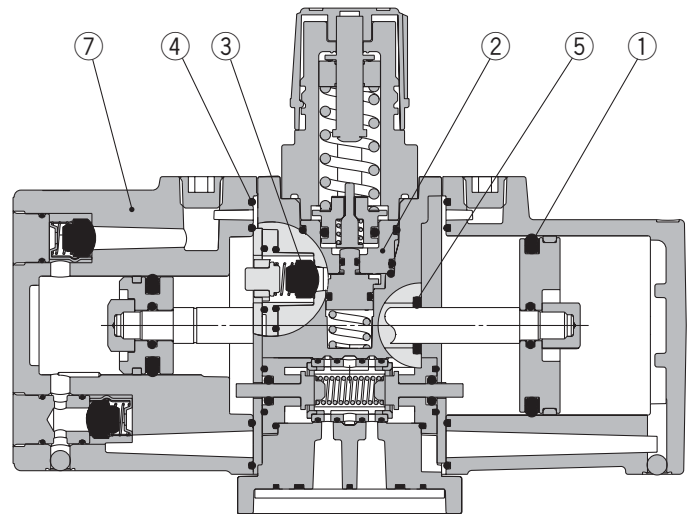

VBA20A, 22A, VBA40A, 42A, 43A

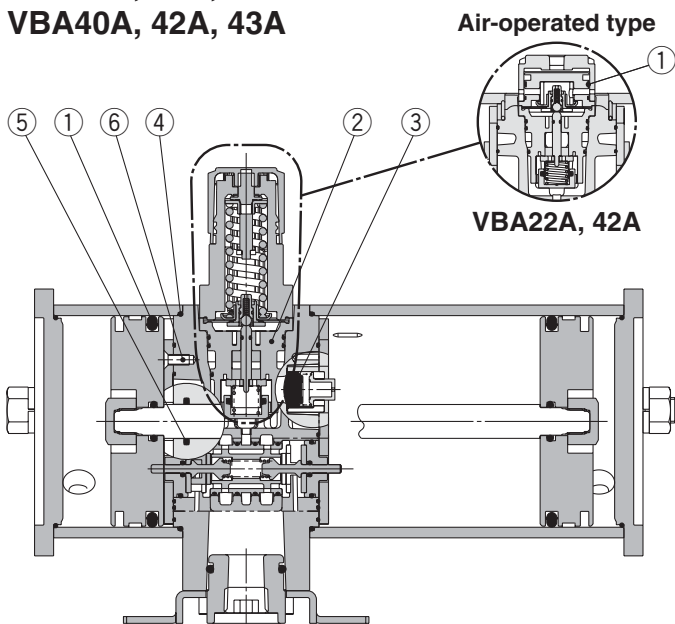

Replacement Parts/Kit No.

Place an order with the following applicable kit number.

Model	VBA10A	VBA20A	VBA40A	VBA22A	VBA42A	VBA43A	VBA11A
Kit no.	KT-VBA10A-1	KT-VBA20A-1	KT-VBA40A-1	KT-VBA22A-1	KT-VBA42A-1	KT-VBA43A-1	KT-VBA11A-20

The kit includes the parts from ① to ⑦ and a grease pack.

No.	Description	Model	VBA10A	VBA20A	VBA40A	VBA22A	VBA42A	VBA43A	VBA11A
			Quantity						
1	Piston seal			2		2 large 1 small		2	1 each large and small
2	Governor assembly					1			
3	Check valve				4				2
4	Gasket					2			
5	Rod seal					1			
6	Mounting screw		—	8	12	8		12	—
7	Cover C assembly								1
—	Grease pack		1		2	1		2	1

* The grease pack has 10 g of grease.

* Make sure to refer to the procedure for maintenance.

Dimensions

VBA10A-02

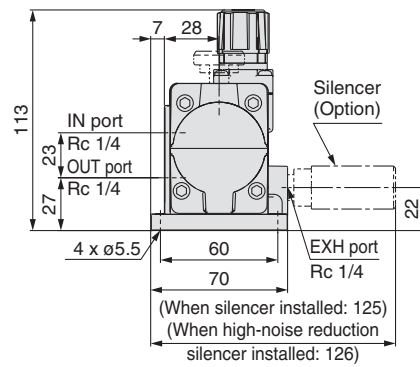
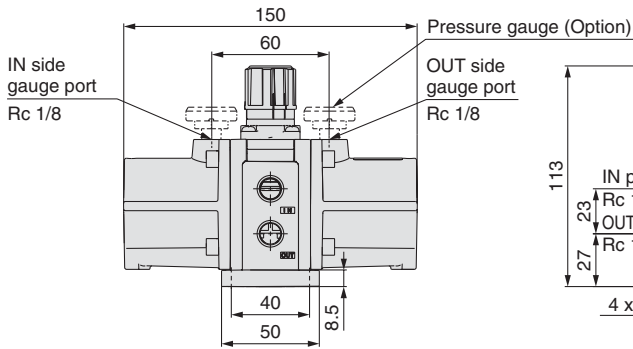

With elbow silencer (Option)

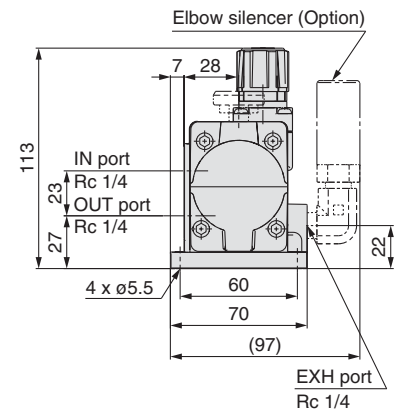

VBA11A-02

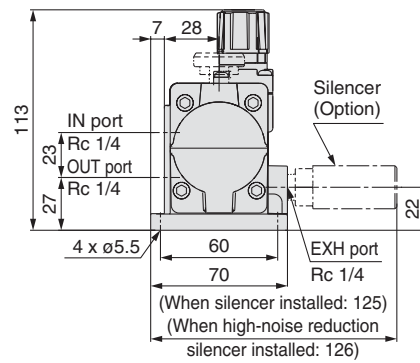
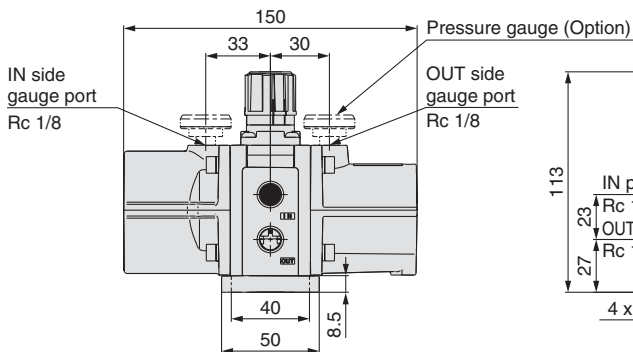

With elbow silencer (Option)

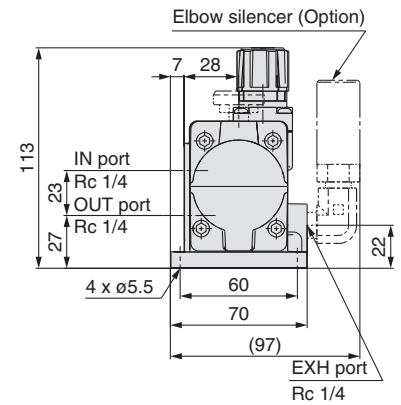

VBA20A-03

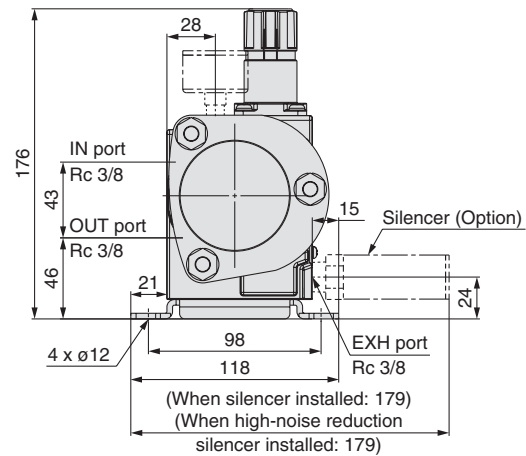
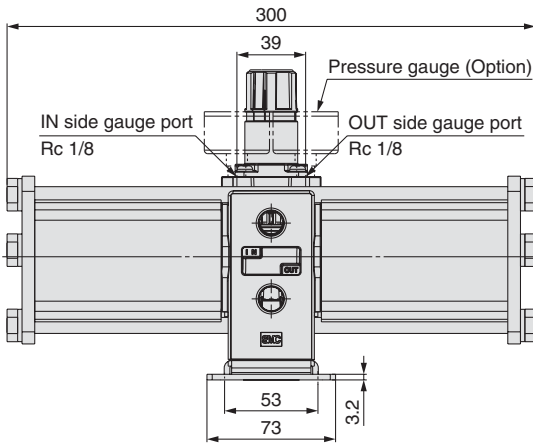

VBA40A-04

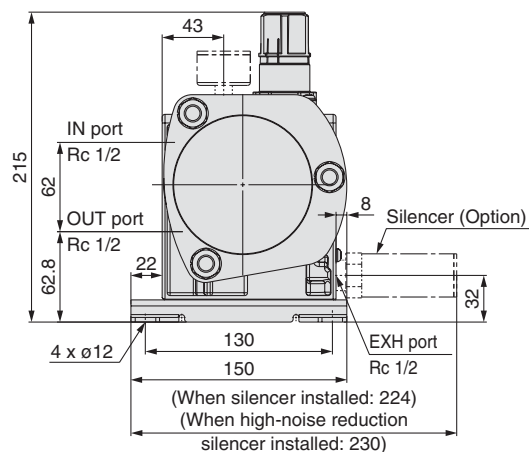
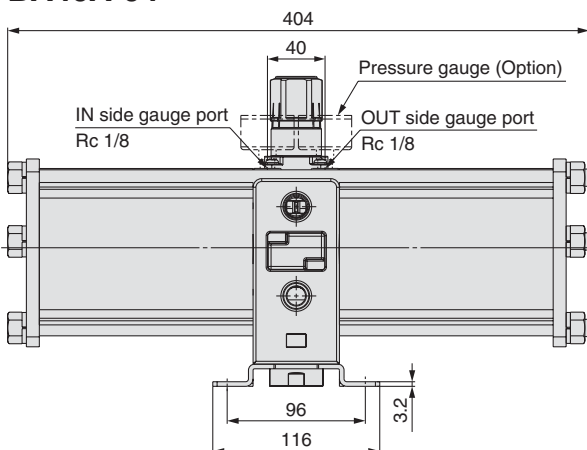

Series VBA

Dimensions

VBA22A-03

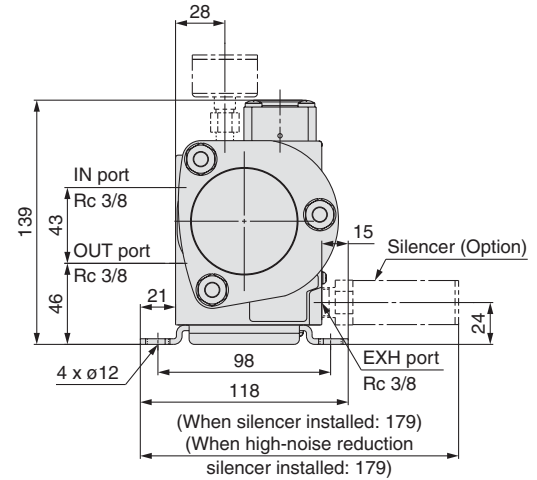
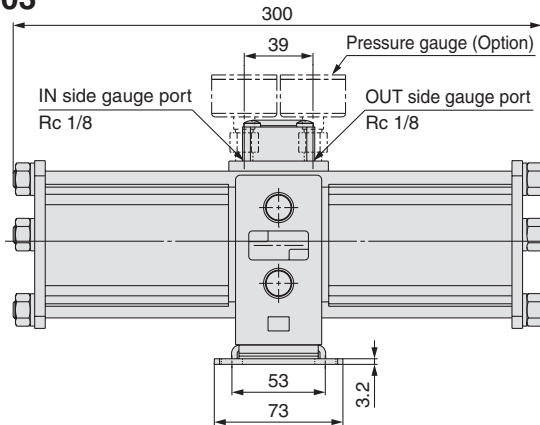

VBA42A-04

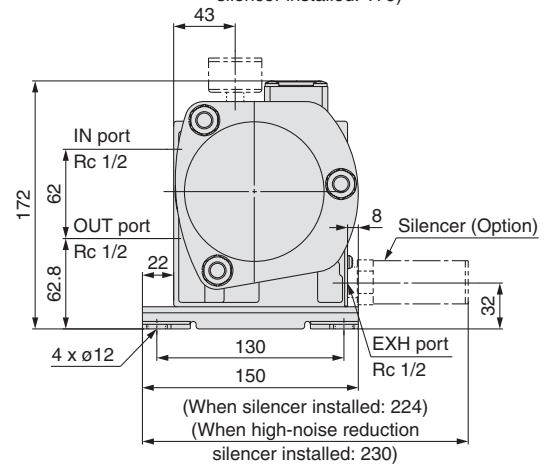
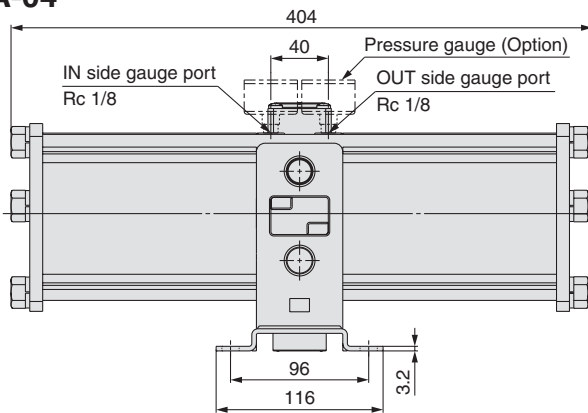

VBA43A-04

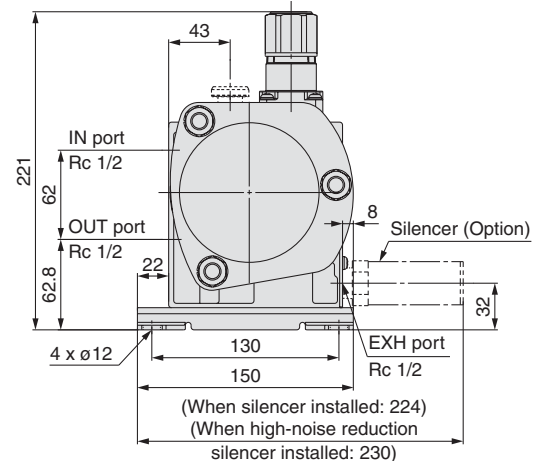
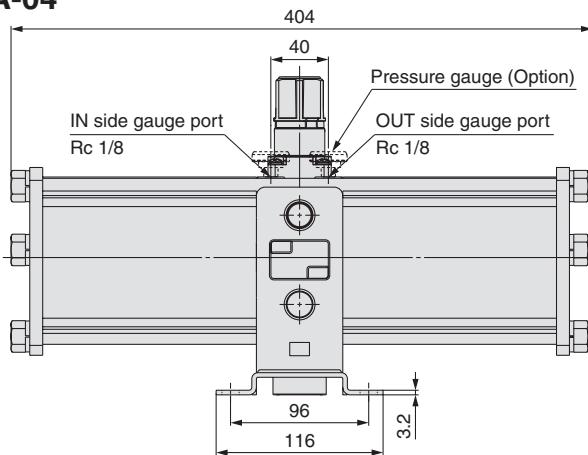

For detailed dimensions, specifications and lead times, please contact SMC.

Made to Order

1 Copper-free/Fluorine-free

The inner or outer copper parts material has been changed to stainless steel or aluminum. The fluorine resin parts has been changed to general resin.

20 — Standard model no.

• Made to Order
Copper-free/Fluorine-free

* For booster regulator with pressure gauge, please consult SMC.
* This option cannot be selected for air tank with safety valve.

2 CE explosion-proof directive (ATEX) compliant

56 — Standard model no.

• Made to Order
CE explosion-proof directive (ATEX):
Category 3GD

3 Ozone resistant

Ozone resistance is strengthened through the use of fluororubber (diaphragm) and hydrogenated NBR (valve, rod seal) for the rubber parts of the seal material.

80 — Standard model no.

• Made to Order
Ozone resistant

* Weather resistant NBR (diaphragm) and hydrogenated NBR (valve) are used for the rubber parts of the standard model.

Air Tank

Series VBAT



Made to Order

(For details, refer to page 11.)

How to Order

- Compact connections are possible with booster regulators.
- It can be used alone as a tank.
- Also partially compatible with overseas standards



VBAT05A1



VBAT10S1



VBAT20S1



VBAT38A1

Standard Product (For Japanese Market)

Note) The thread type for each port is Rc.

VBAT 10 A 1 - S

Tank internal capacity

Symbol	Internal capacity
05	5 L
10	10 L
20	20 L
38	38 L

Material

Symbol	Material
A	Carbon steel (SS400)
S	Stainless steel 304

Option

Symbol	Option
Nil	None
V	Drain valve

Option

Symbol	Option	Applicable model
Nil	None Note)	All models
R	Safety valve (Set pressure: 1 MPa)	VBAT05A1, VBAT10A1, VBAT20A1, VBAT38A1
S	Safety valve (Set pressure: 2 MPa)	VBAT05A1, VBAT10A1

Note) A safety valve port is provided only when option R or S is selected.

CE Certified Product

VBAT 10 A F - SV - Q

Tank internal capacity

Symbol	Internal capacity
05	5 L
10	10 L
20	20 L
38	38 L

Material

Symbol	Material
A	Carbon steel (SS400)

CE certified product (Self-declaration document attached)

Accessories

Symbol	Accessories	Applicable model
RV	Safety valve (Set pressure: 1 MPa) Drain valve	VBAT20A VBAT38A
SV	Safety valve (Set pressure: 2 MPa) Drain valve	VBAT05A VBAT10A

Thread type

Symbol	Thread type
Nil	Rc
F	G

⚠ Caution

When used as a single unit (not connected with a booster regulator) and pressurized at over 1 MPa at normal temperatures, the air tank falls under the scope of the "High Pressure Gas Safety Act" in Japan.

Product Not Applicable to the ASME Standard

VBAT 05 A N 1 - SV - X11

Tank internal capacity

Symbol	Internal capacity
05	5 L
10	10 L

Material

Symbol	Material
A	Carbon steel (SS400)

Thread type

Symbol	Thread type
Nil	Rc
N	NPT Note)

Product not applicable to the ASME standard

Option

Symbol	Option
Nil	None Note 1)
V	Drain valve Note 1)
S	Safety valve (Set pressure: 2 MPa) Note 1)
SV	Safety valve (Set pressure: 2 MPa) Note 2) Drain valve

Note 1) Customers are responsible for preparing a safety valve.

Note 2) Safety valve does not meet ASME specifications.

Note) Pressure unit of NPT products: psi. This product is for overseas use only according to the new Measurement Law. (The SI unit type is provided for use in Japan.)

Series VBAT

Specifications

Standard Product (For Japanese Market)

Model	VBAT05□1	VBAT10□1	VBAT20□1	VBAT38□1	
Fluid	Compressed air				
Tank capacity (L)	5	10	20	38	
Max. operating pressure (MPa)	VBAT□A1	2.0		1.0	
	VBAT□S1	2.0			
IN port size	3/8	3/8	1/2	1/2	
OUT port size	3/8	1/2	1/2	3/4	
Ambient and fluid temperature (°C)	0 to 75				
Weight (kg)	VBAT□A1	6.6	10	14	21
	VBAT□S1	3.2	4.9	12	19
Material	VBAT□A1	Carbon steel (SS400)			
	VBAT□S1	Stainless steel 304			
Paint	VBAT□A1	Outside: Silver paint, Inside: Rustproof paint			
	VBAT□S1	None			

Note) The accessories and options are included in the same container.

CE Certified Product

Model	VBAT05A □-SV-Q	VBAT10A □-SV-Q	VBAT20A □-RV-Q	VBAT38A □-SV-Q
Fluid	Compressed air			
Tank capacity (L)	5	10	20	38
Max. operating pressure (MPa)	2.0		1.0	
IN port size	3/8	1/2	3/4	3/4
OUT port size	3/8	1/2	1/2	3/4
Ambient and fluid temperature (°C)	0 to 75			
Weight (kg)	6.6	10	14	21
Material	Carbon steel (SS400)			
Paint	Outside: Silver paint, Inside: Rustproof paint			

Note) The accessories and options are included in the same container.

Product Not Applicable to the ASME Standard

Model	VBAT05A□1-□-X11	VBAT10A□1-□-X11
Fluid	Compressed air	
Tank capacity (L)	5	10
Max. operating pressure (MPa)	2.0	
IN port size	3/8	3/8
OUT port size	3/8	1/2
Ambient and fluid temperature (°C)	0 to 75	
Weight (kg)	6.6	11
Material	Carbon steel (SS400)	
Paint	Outside: Silver paint, Inside: Rustproof paint	

Note) The accessories and options are included in the same container.

Design

⚠ Warning

1. Operating pressure

- Operate this product below the maximum operating pressure. If it is necessary, take appropriate safety measures to ensure that the maximum operating pressure is not exceeded.

• When the tank alone is used

Use a pressure switch or a safety valve to ensure that the maximum operating pressure is not exceeded.

2. Connection

- Connect a filter or a mist separator to the OUT side of the tank. Because the inner surface of the tank is untreated, there is a possibility of dust flowing out to the outlet side.

- A VBA booster regulator can be connected directly with the tank accessories as indicated combinations below.

		Booster regulator		
		VBA1□A	VBA2□A	VBA4□A
Air tank	VBAT05A	●	—	—
	VBAT05S	●	●	—
	VBAT10A	—	●	●
	VBAT10S	—	●	●
	VBAT20A	—	●	●
	VBAT20S	—	●	●
VBAT38A	—	●	●	
VBAT38S	—	●	●	

Selection

⚠ Caution

- Consider the operating conditions and operate this product within the specification range.
- When using the air tank with a booster regulator, refer to "Sizing" on page 5 or SMC Pneumatic System Energy Saving Program.

Mounting

⚠ Caution

1. Accessories

- Refer to the operation manual (VBAT-M1, M2, M3, M4) regarding combining booster regulators with older model air tanks.

- The accessories are secured by bands to the feet of the air tank. Once removed, make sure not to lose them.

2. Installation

- Install the tank away from people. It is dangerous if the accumulated air inside the tank were to seep out.

- Do not mount the air tank on a moving part or a place with vibration.

- When connecting a booster regulator with the tank, refer to the operation manual first, which is provided with the air tank before assembling.

- Refer to the operation manual regarding mounting methods when using long bolts.

- To mount the air tank on a floor surface, use the four holes to secure the tank with bolts or anchor bolts.

Maintenance

⚠ Warning

1. Inspection

- The use of pressure vessels could lead to an unexpected accident due to external damage or internal corrosion caused by drainage. Therefore, make sure to check periodically for external damage, or the extent of internal corrosion through the port hole. An ultrasonic thickness indicator may also be used to check for any reduction in material thickness.

2. Draining

- If this product is used with a large amount of drainage, the drainage could flow out, leading to equipment malfunction or corrosion inside the tank. Therefore, drain the system once a day.

List of Air Tank for Overseas

Country/Region	Law	Exportable models		Details
		Material: Carbon steel	Material: Stainless steel	
Singapore, Malaysia	Factory Act	VBAT05A-SV-X102	/	Product complies with ASME specifications JBA (Japan Boiler Association) certification attached
		VBAT10A-SV-X102		
		VBAT20A-RV-X102		
		VBAT38A-RV-X102		
Thailand, Taiwan	No applicable standard	Standard product		

Options/Accessories/Part No.

<Standard Product>

For VBAT□A1 (Carbon Steel)

Model	VBAT05A1-□	VBAT10A1-□	VBAT20A1-□	VBAT38A1-□
Accessory kit	VBAT5A-Y-3	VBAT10A-Y-3	VBAT20A-Y-3	
Safety valve (When selecting an option) ^{Note 1) 2)}	VBAT-R (Set pressure: 1 MPa), VBAT-S (Set pressure: 2 MPa)		VBAT-R (Set pressure: 1 MPa)	
Drain valve (When selecting an option)	VBAT-V1			

Note 1) The set pressure of the safety valve cannot be changed.

Note 2) The safety valve is a safety measure that protects the tank from excess pressure. The valve opens automatically when the specified pressure is reached, releasing excess pressure inside the tank. The valve closes again when the pressure drops below a designated value. Select a pressure valve appropriate for the maximum operating pressure specification of the tank.

For VBAT□S1 (Stainless Steel)

Model	VBAT05S1-□	VBAT10S1-□	VBAT20S1-□	VBAT38S1-□
Accessory kit	VBAT5S-Y-4	VBAT10S-Y-4	VBAT20A-Y-4	
Drain valve (When selecting an option)	VBAT-V1			

<CE Certified Product>

Model	VBAT05A□-SV-Q	VBAT10A□-SV-Q	VBAT20A□-RV-Q	VBAT38A□-RV-Q
Accessory kit	VBAT5A-Y-2	VBAT10A-Y-2	VBAT20A-Y-2	
Safety valve	VBAT-S (Set pressure: 2 MPa)		VBAT-R (Set pressure: 1 MPa)	
Drain valve	VBAT-V1			

<Product Not Applicable to the ASME Standard>

Model	VBAT05A*1-□-X11	VBAT10A*1-□-X11
Accessory kit	VBAT5A-Y-3*	VBAT10A-Y-3*
Safety valve (When selecting an option)	VBAT-S* (Set pressure: 2 MPa)	
Drain valve	VBAT-V1*	

Note) *: Nil when Rc thread is selected, N when NPT thread is selected.

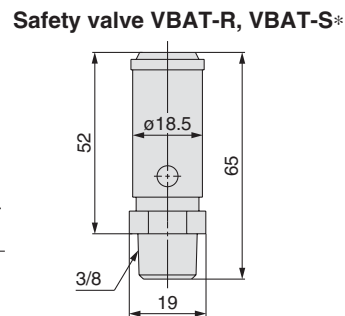
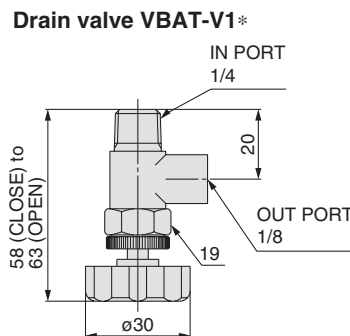
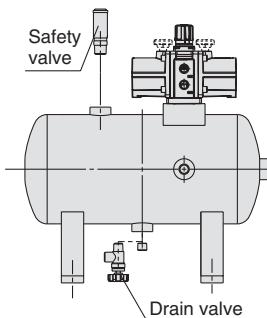

Made to Order



For detailed dimensions, specifications and lead times, please contact SMC.

1 Copper-free/Fluorine-free

Made to Order ● Copper-free/Fluorine-free ● Tank internal capacity ● Material ● With drain valve

Symbol	Internal capacity
05	5 L
10	10 L
20	20 L
38	38 L

Symbol	Material
A	Carbon steel (SS400)
S	Stainless steel 304

Note 1) The thread type for each port is Rc.

Note 2) A stainless steel fitting and a drain valve are included in the same container as accessories. (For detailed dimensions, please contact SMC.) A safety valve cannot be selected.

Note 3) Since neither copper nor fluorine parts are used for the tank, a standard model can be used when options (safety valve and drain valve) are not necessary.

Series VBAT

Dimensions: Standard Product (For Japanese Market)

VBAT05A1 Material: Carbon steel

Connected to VBA10A, 11A

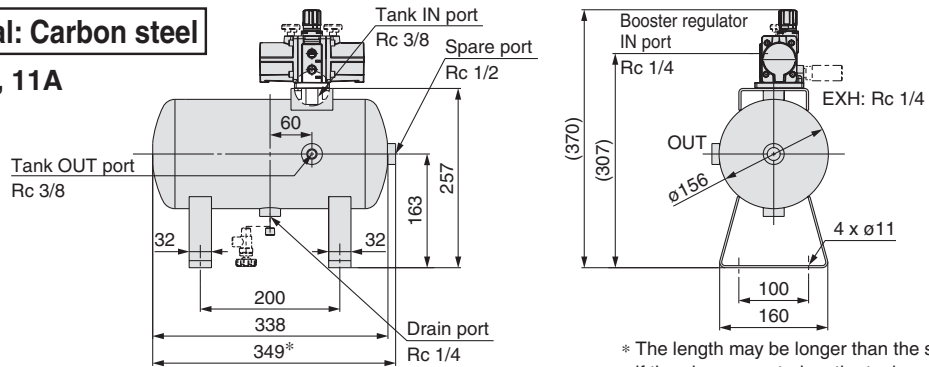

* The length may be longer than the specification if the plugs mounted on the tank are not fit to the end.

VBAT10A1 Material: Carbon steel

Connected to VBA10A, 11A

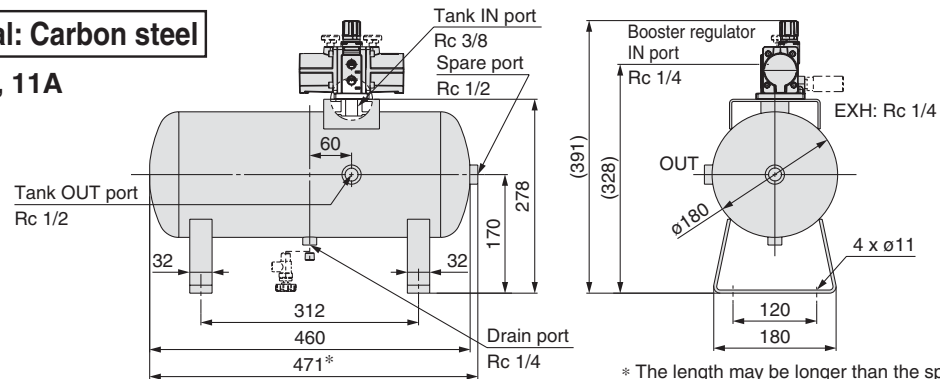

* The length may be longer than the specification if the plugs mounted on the tank are not fit to the end.

Connected to VBA20A

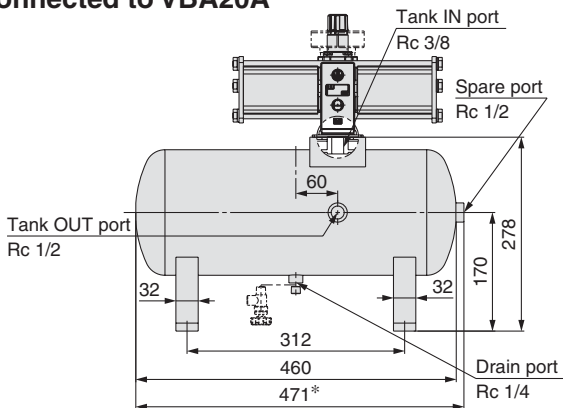

Connected to VBA22A

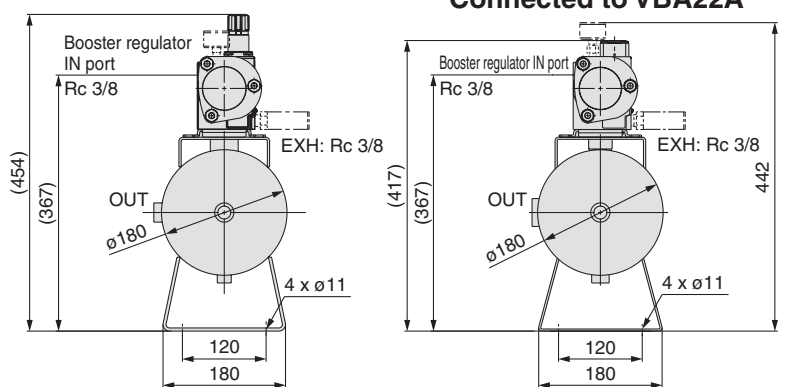

* The length may be longer than the specification if the plugs mounted on the tank are not fit to the end.

VBAT20A1 Material: Carbon steel

Connected to VBA20A, 40A

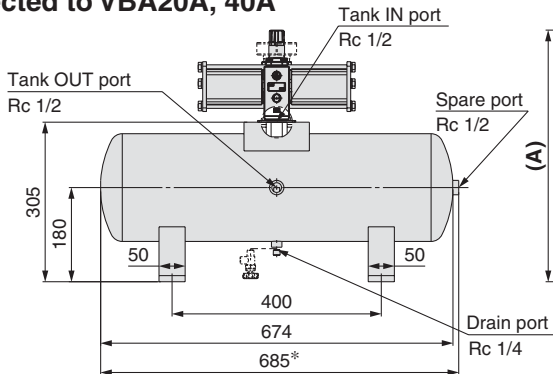

Connected to VBA22A, 42A

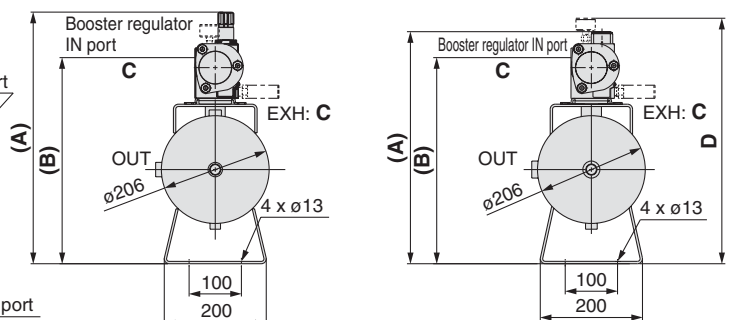

* The length may be longer than the specification if the plugs mounted on the tank are not fit to the end.

Booster regulator model	A	B	C	D (Note)
VBA20A	481	394	Rc 3/8	—
VBA40A	520	429.8	Rc 1/2	—
VBA22A	444	394	Rc 3/8	469
VBA42A	477	429.8	Rc 1/2	493

Note) When option G (pressure gauge) is selected

Dimensions: Standard Product (For Japanese Market)

VBAT38A1 Material: Carbon steel

Connected to VBA20A, 40A

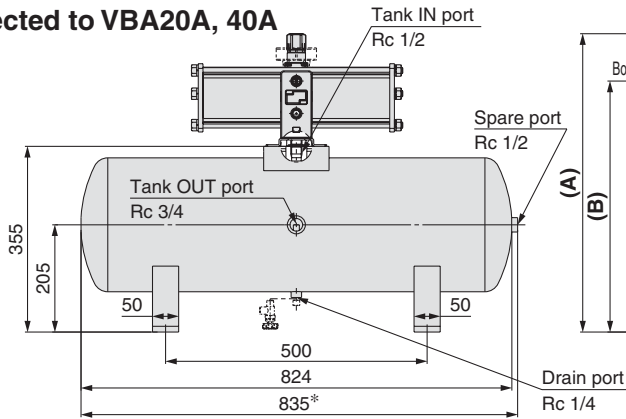

Connected to VBA22A, 42A

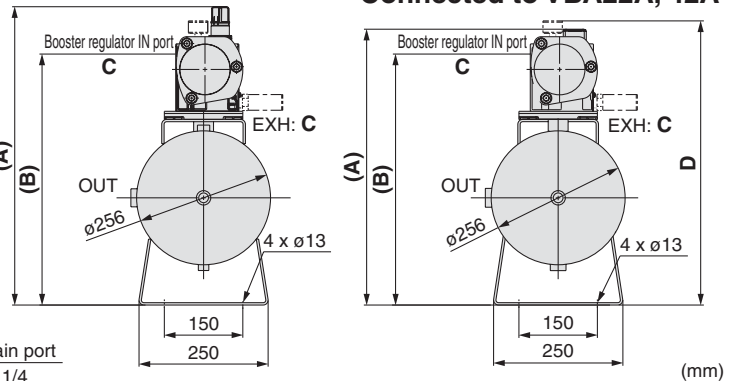

Booster regulator model	A	B	C	D (Note)
VBA20A	531	444	Rc 3/8	—
VBA40A	570	479.8	Rc 1/2	—
VBA22A	494	444	Rc 3/8	519
VBA42A	527	479.8	Rc 1/2	543

Note) When option G (pressure gauge) is selected

* The length may be longer than the specification if the plugs mounted on the tank are not fit to the end.

VBAT05S1 Material: Stainless steel 304

Connected to VBA10A, 11A

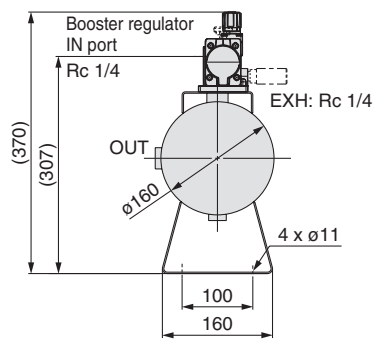
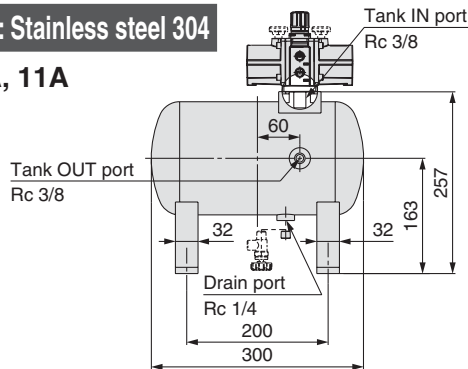

VBAT10S1 Material: Stainless steel 304

Connected to VBA10A, 11A

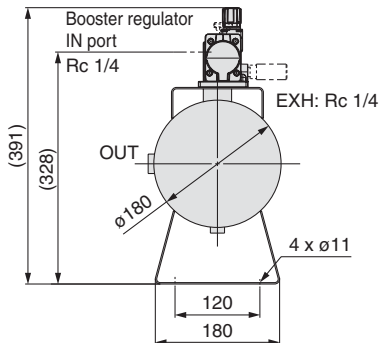
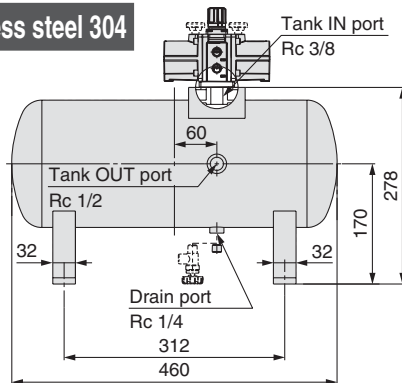

Connected to VBA20A

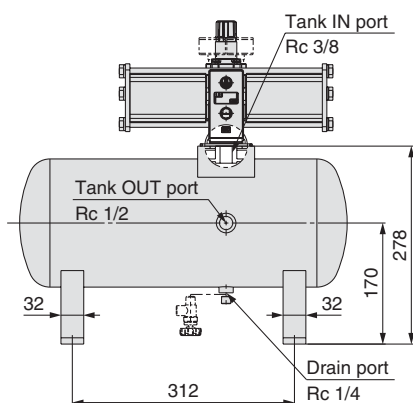

Connected to VBA22A

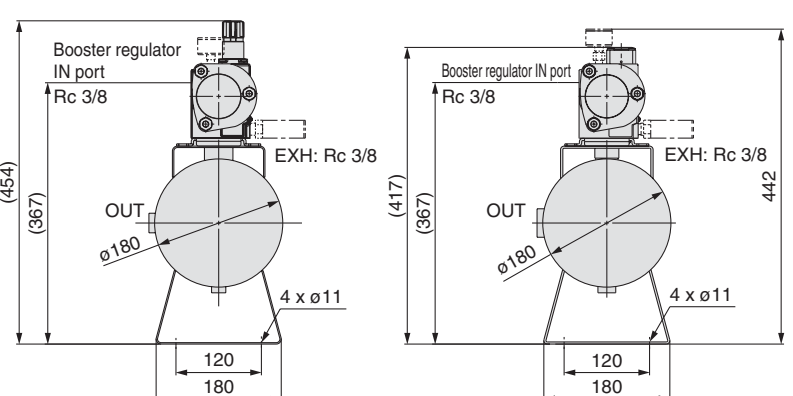

Series VBAT

Dimensions: Standard Product (For Japanese Market)

VBAT20S1 Material: Stainless steel 304

Connected to VBA20A, 40A

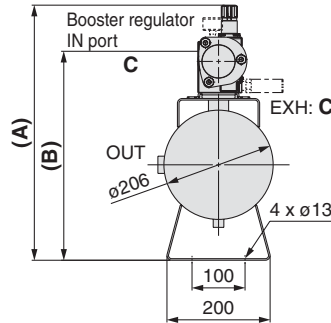
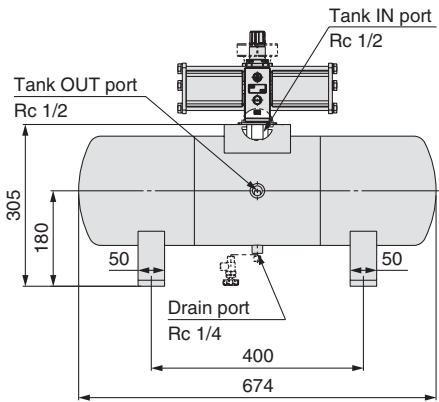

Connected to VBA22A, 42A, 43A

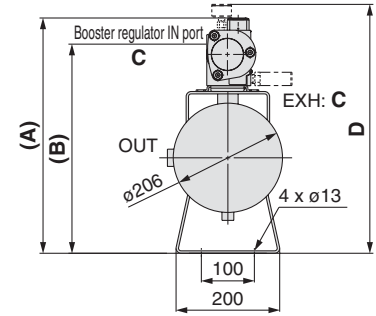

Booster regulator model	A	B	C	D (Note)
VBA20A	481	394	Rc 3/8	—
VBA40A	520	429.8	Rc 1/2	—
VBA22A	444	394	Rc 3/8	469
VBA42A	477	429.8	Rc 1/2	493
VBA43A	526	—	—	—

Note) When option G (pressure gauge) is selected

VBAT38S1 Material: Stainless steel 304

Connected to VBA20A, 40A

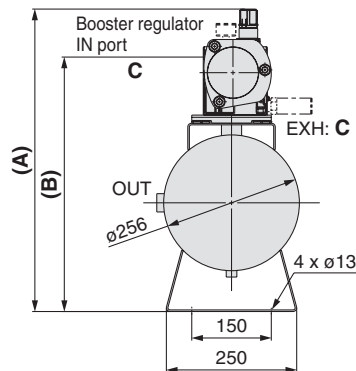
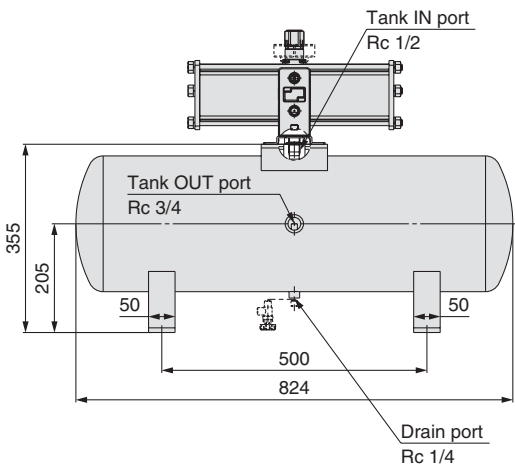

Connected to VBA22A, 42A, 43A

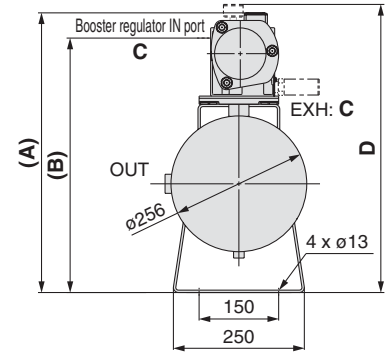

Booster regulator model	A	B	C	D (Note)
VBA20A	531	444	Rc 3/8	—
VBA40A	570	479.8	Rc 1/2	—
VBA22A	494	444	Rc 3/8	519
VBA42A	527	479.8	Rc 1/2	543
VBA43A	576	—	—	—

Note) When option G (pressure gauge) is selected

VBAT⁰⁵₁₀A1-R With safety valve

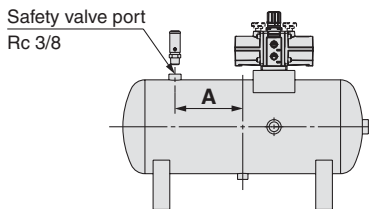

Tank model	A
VBAT05	60
VBAT10	130

VBAT²⁰₃₈A1-R With safety valve

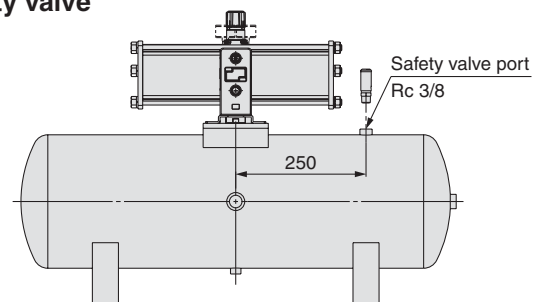

Dimensions: CE Certified Product

VBAT05A-Q Material: Carbon steel

Connected to VBA10A, 11A

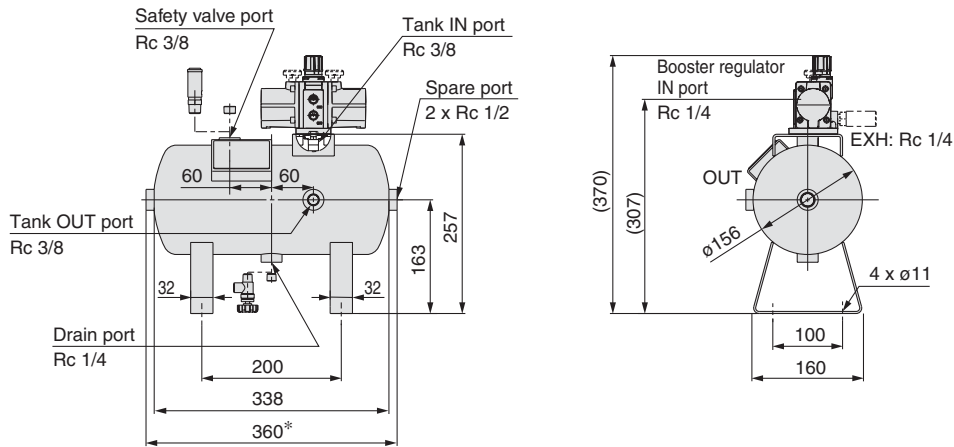

* The length may be longer than the specification if the plugs mounted on the tank are not fit to the end.
The length of G thread type is about 6 mm longer due to plug type differences.

VBAT10A-Q Material: Carbon steel

Connected to VBA10A, 11A

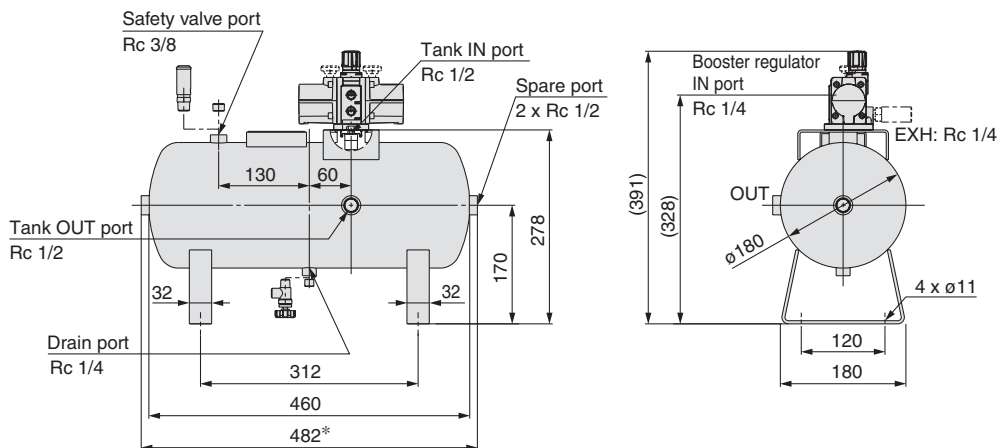

* The length may be longer than the specification if the plugs mounted on the tank are not fit to the end.
The length of G thread type is about 6 mm longer due to plug type differences.

Connected to VBA20A

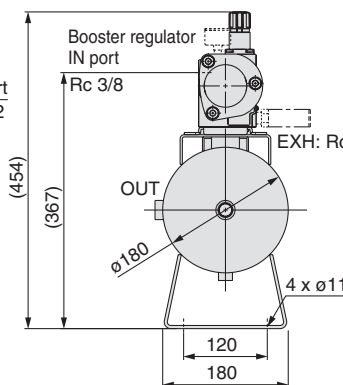
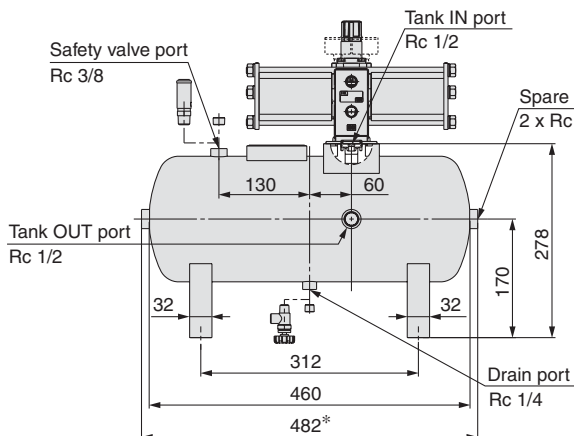

Connected to VBA22A

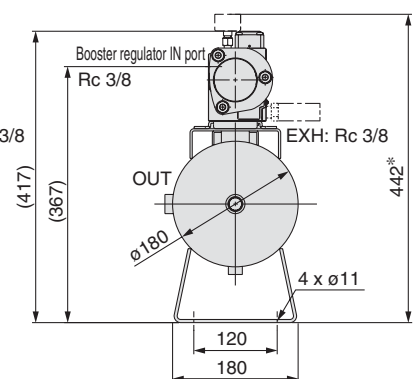

* When option G (pressure gauge) is selected

* The length may be longer than the specification if the plugs mounted on the tank are not fit to the end.
The length of G thread type is about 6 mm longer due to plug type differences.

Series VBAT

Dimensions: CE Certified Product

VBAT20A-Q Material: Carbon steel

Connected to VBA20A, 40A

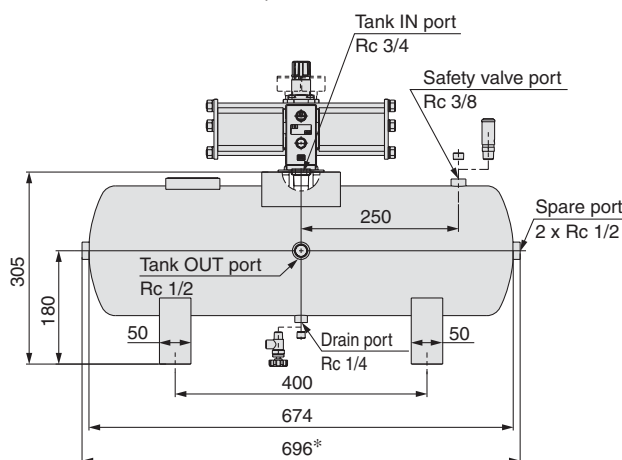

Connected to VBA22A, 42A

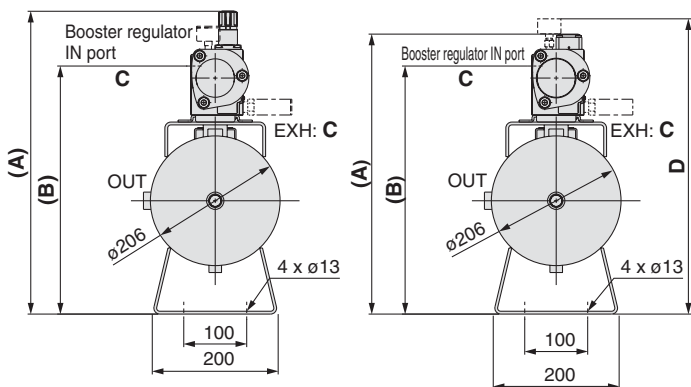

* The length may be longer than the specification if the plugs mounted on the tank are not fit to the end.
The length of G thread type is about 6 mm longer due to plug type differences.

Booster regulator model	A	B	C	D (Note)
VBA20A	481	394	Rc 3/8	—
VBA40A	520	429.8	Rc 1/2	—
VBA22A	444	394	Rc 3/8	469
VBA42A	477	429.8	Rc 1/2	493

Note) When option G (pressure gauge) is selected

VBAT38A-Q Material: Carbon steel

Connected to VBA20A, 40A

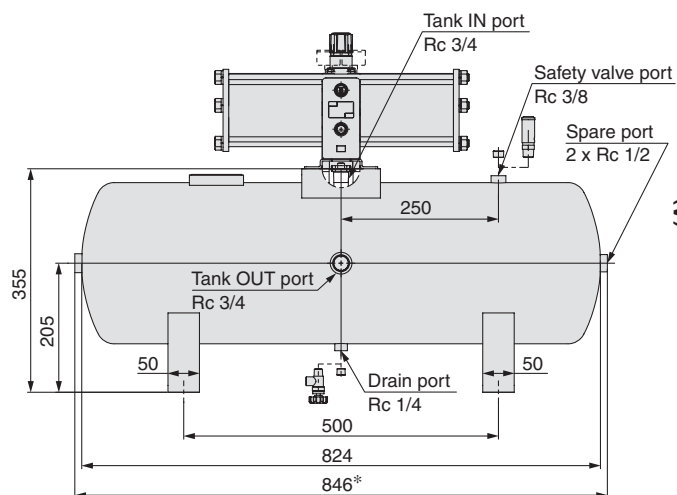

Connected to VBA22A, 42A

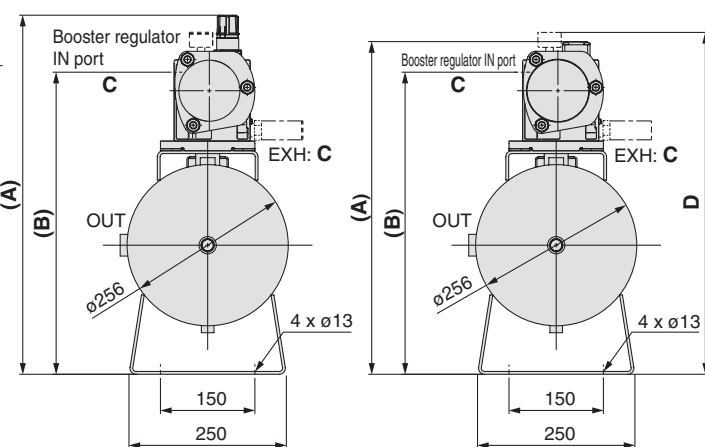

* The length may be longer than the specification if the plugs mounted on the tank are not fit to the end.
The length of G thread type is about 6 mm longer due to plug type differences.

Booster regulator model	A	B	C	D (Note)
VBA20A	531	444	Rc 3/8	—
VBA40A	570	479.8	Rc 1/2	—
VBA22A	494	444	Rc 3/8	519
VBA42A	527	479.8	Rc 1/2	543

Note) When option G (pressure gauge) is selected

Dimensions: Product Not Applicable to the ASME Standard

VBAT05A1-X11 Material: Carbon steel

Connected to VBA10A, 11A

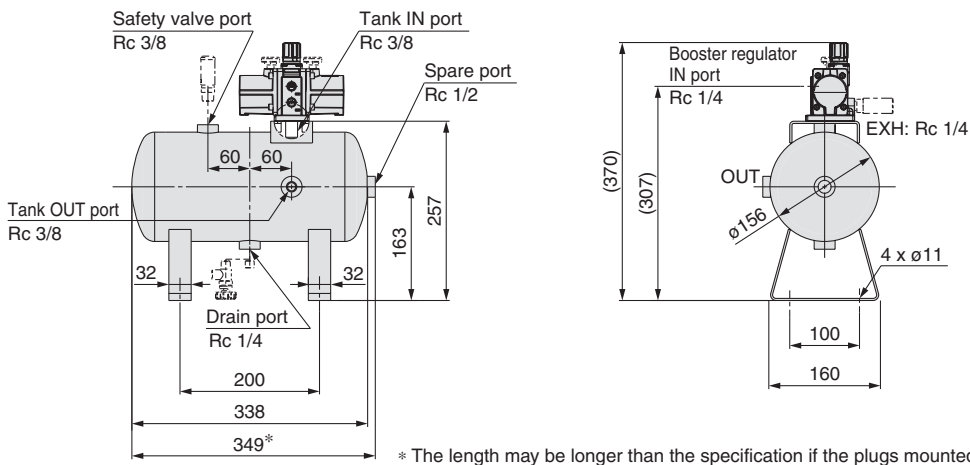

VBAT10A1-X11 Material: Carbon steel

Connected to VBA10A, 11A

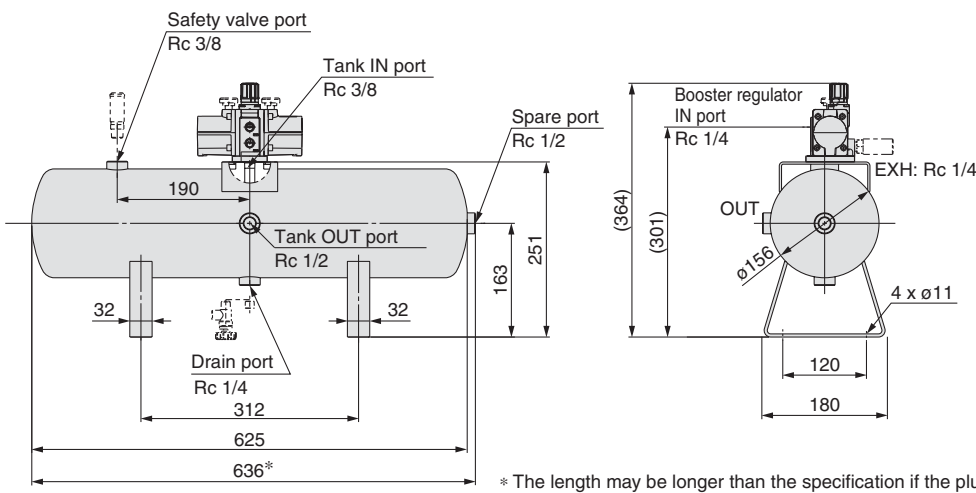

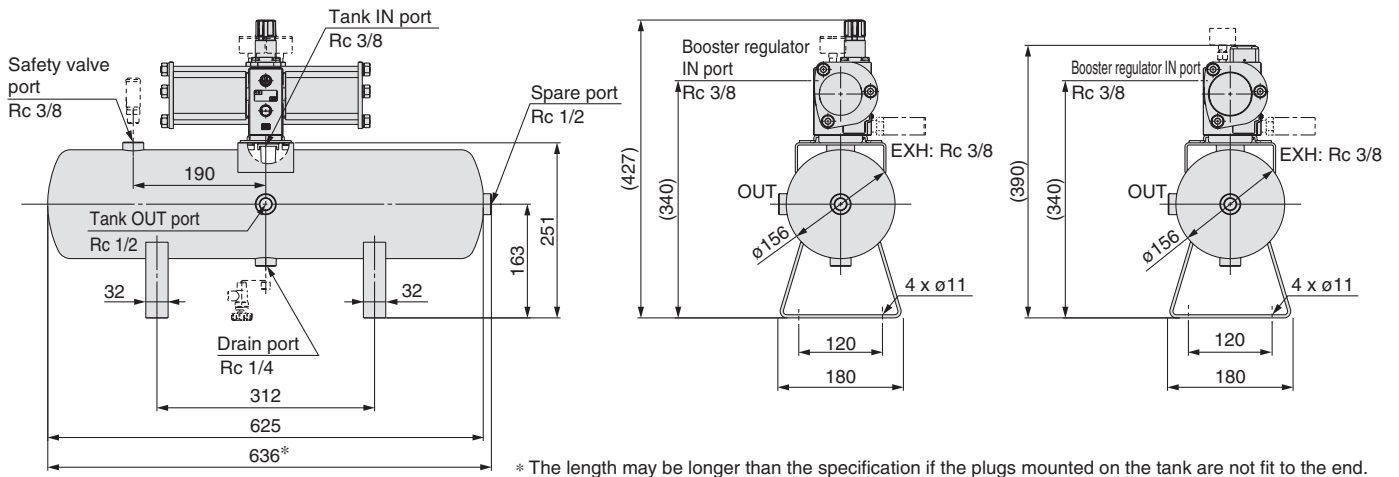

Connected to VBA20A

Connected to VBA22A



Safety Instructions

These safety instructions are intended to prevent hazardous situations and/or equipment damage. These instructions indicate the level of potential hazard with the labels of “**Caution**,” “**Warning**” or “**Danger**.” They are all important notes for safety and must be followed in addition to International Standards (ISO/IEC)*1), and other safety regulations.

-  **Caution:** **Caution** indicates a hazard with a low level of risk which, if not avoided, could result in minor or moderate injury.
-  **Warning:** **Warning** indicates a hazard with a medium level of risk which, if not avoided, could result in death or serious injury.
-  **Danger:** **Danger** indicates a hazard with a high level of risk which, if not avoided, will result in death or serious injury.

- *1) ISO 4414: Pneumatic fluid power – General rules relating to systems.
 ISO 4413: Hydraulic fluid power – General rules relating to systems.
 IEC 60204-1: Safety of machinery – Electrical equipment of machines.
 (Part 1: General requirements)
 ISO 10218-1: Manipulating industrial robots - Safety.
 etc.

Warning

- The compatibility of the product is the responsibility of the person who designs the equipment or decides its specifications.**
 Since the product specified here is used under various operating conditions, its compatibility with specific equipment must be decided by the person who designs the equipment or decides its specifications based on necessary analysis and test results. The expected performance and safety assurance of the equipment will be the responsibility of the person who has determined its compatibility with the product. This person should also continuously review all specifications of the product referring to its latest catalog information, with a view to giving due consideration to any possibility of equipment failure when configuring the equipment.
- Only personnel with appropriate training should operate machinery and equipment.**
 The product specified here may become unsafe if handled incorrectly. The assembly, operation and maintenance of machines or equipment including our products must be performed by an operator who is appropriately trained and experienced.
- Do not service or attempt to remove product and machinery/equipment until safety is confirmed.**
 - The inspection and maintenance of machinery/equipment should only be performed after measures to prevent falling or runaway of the driven objects have been confirmed.
 - When the product is to be removed, confirm that the safety measures as mentioned above are implemented and the power from any appropriate source is cut, and read and understand the specific product precautions of all relevant products carefully.
 - Before machinery/equipment is restarted, take measures to prevent unexpected operation and malfunction.
- Contact SMC beforehand and take special consideration of safety measures if the product is to be used in any of the following conditions.**
 - Conditions and environments outside of the given specifications, or use outdoors or in a place exposed to direct sunlight.
 - Installation on equipment in conjunction with atomic energy, railways, air navigation, space, shipping, vehicles, military, medical treatment, combustion and recreation, or equipment in contact with food and beverages, emergency stop circuits, clutch and brake circuits in press applications, safety equipment or other applications unsuitable for the standard specifications described in the product catalog.
 - An application which could have negative effects on people, property, or animals requiring special safety analysis.
 - Use in an interlock circuit, which requires the provision of double interlock for possible failure by using a mechanical protective function, and periodical checks to confirm proper operation.

Caution

- The product is provided for use in manufacturing industries.**
 The product herein described is basically provided for peaceful use in manufacturing industries.
 If considering using the product in other industries, consult SMC beforehand and exchange specifications or a contract if necessary.
 If anything is unclear, contact your nearest sales branch.

Limited warranty and Disclaimer/ Compliance Requirements

The product used is subject to the following “Limited warranty and Disclaimer” and “Compliance Requirements”.
 Read and accept them before using the product.

Limited warranty and Disclaimer

- The warranty period of the product is 1 year in service or 1.5 years after the product is delivered.*2)
 Also, the product may have specified durability, running distance or replacement parts. Please consult your nearest sales branch.
- For any failure or damage reported within the warranty period which is clearly our responsibility, a replacement product or necessary parts will be provided.
 This limited warranty applies only to our product independently, and not to any other damage incurred due to the failure of the product.
- Prior to using SMC products, please read and understand the warranty terms and disclaimers noted in the specified catalog for the particular products.
 - *2) Vacuum pads are excluded from this 1 year warranty.
 A vacuum pad is a consumable part, so it is warranted for a year after it is delivered. Also, even within the warranty period, the wear of a product due to the use of the vacuum pad or failure due to the deterioration of rubber material are not covered by the limited warranty.

Compliance Requirements

- The use of SMC products with production equipment for the manufacture of weapons of mass destruction (WMD) or any other weapon is strictly prohibited.
- The exports of SMC products or technology from one country to another are governed by the relevant security laws and regulations of the countries involved in the transaction. Prior to the shipment of a SMC product to another country, assure that all local rules governing that export are known and followed.

Revision history	Edition B	* Addition of booster regulators/air-operated type, VBA22A/42A * Addition of booster regulator with max. operating pressure of 1.6 MPa, VBA43A * Number of pages increased from 24 to 28	MY	Edition D	* Addition of booster regulator, VBA11A * Deletion of booster regulator, VBA1111 * Addition of air tanks, CE certified * Addition of air tanks, not applicable to the ASME standard * Addition of an elbow silencer to options * Number of pages increased from 20 to 24	OW
	Edition C	* Addition of booster regulator, VBA10A * Deletion of booster regulator, VBA1110 Change of accessories/part no. of air tank, VBAT series Change of dimensions of air tank, VBAT series * Number of pages decreased from 28 to 20	NY			

Safety Instructions

Be sure to read “Handling Precautions for SMC Products” (M-E03-3) before using.

SMC Corporation

Akihabara UDX 15F,
 4-14-1, Sotokanda, Chiyoda-ku, Tokyo 101-0021, JAPAN
 Phone: 03-5207-8249 Fax: 03-5298-5362
 URL <http://www.smcworld.com>
 © 2010 SMC Corporation All Rights Reserved

Specifications are subject to change without prior notice and any obligation on the part of the manufacturer.

D-DN

1st printing MP printing OW 7150SZ Printed in Japan.