

Booster Lube Series ALB900

Centralized control of multi-point lubrication

Stable oil feeding with a micromist

Through the use of a booster, a pressure that is higher than that of the main air passage can be supplied. This difference is used as the mist generating pressure differential. Thus, the pressure drop in the main air passage is minimized.

Micromist can be constantly supplied by merely adjusting the mist generating pressure differential.

Oil can be replenished by merely opening and closing the oil filler plug without stopping the air line.

The condition of the generation of micromist can be checked from the oil filler port.



ALB900-00-11

Standard Specification

Model	ALB900-10	ALB900-20	ALB900-30
Port (Bypass lubrication adapter)	Rc(PT)1	Rc(PT)2	3 inch flange
Port size (Body)	IN: Rc(PT) 1/4 OUT: Rc(PT) 1/2		
Fluid	Air		
Proof pressure	1.5MPa		
Operating pressure range	0.4 to 1.0MPa		
Operating pressure differential range	0.05 to 0.2MPa		
Bowl capacity between levels (cm ³)	5000		
Recommended oil	Turbine oil class 1 ISO VG32		
Ambient and fluid temperature	5 to 50°C		
Bowl material	Epoxy resin with glass fiber, Polycarbonate		
Weight (kg)	28		

Accessories (Options) Part No.

Type	Description	Model	Part No.		
			ALB900-10	ALB900-20	ALB900-30
Standard attachment	Bypass lubrication adapter		ALBA90-10	ALBA90-20	ALBA90-30
	Ball valve			1/4 B	
	Ball valve			1/2 B	

How to Order

ALB 900 - 10 - 0 0 - Q

Booster Lube

Body size

900 | 2 inch standard

Port size

(Bypass lubrication adapter)

00	None
10	Rc(PT)1
20	Rc(PT)2
30	3 inch flange

Operation control signal

0	Air pilot
1	100V AC
2	200V AC
4	220V AC
5	24V DC
9	Other

Operation control

0	Air pilot
1	Solenoid

ALB900

Piping example

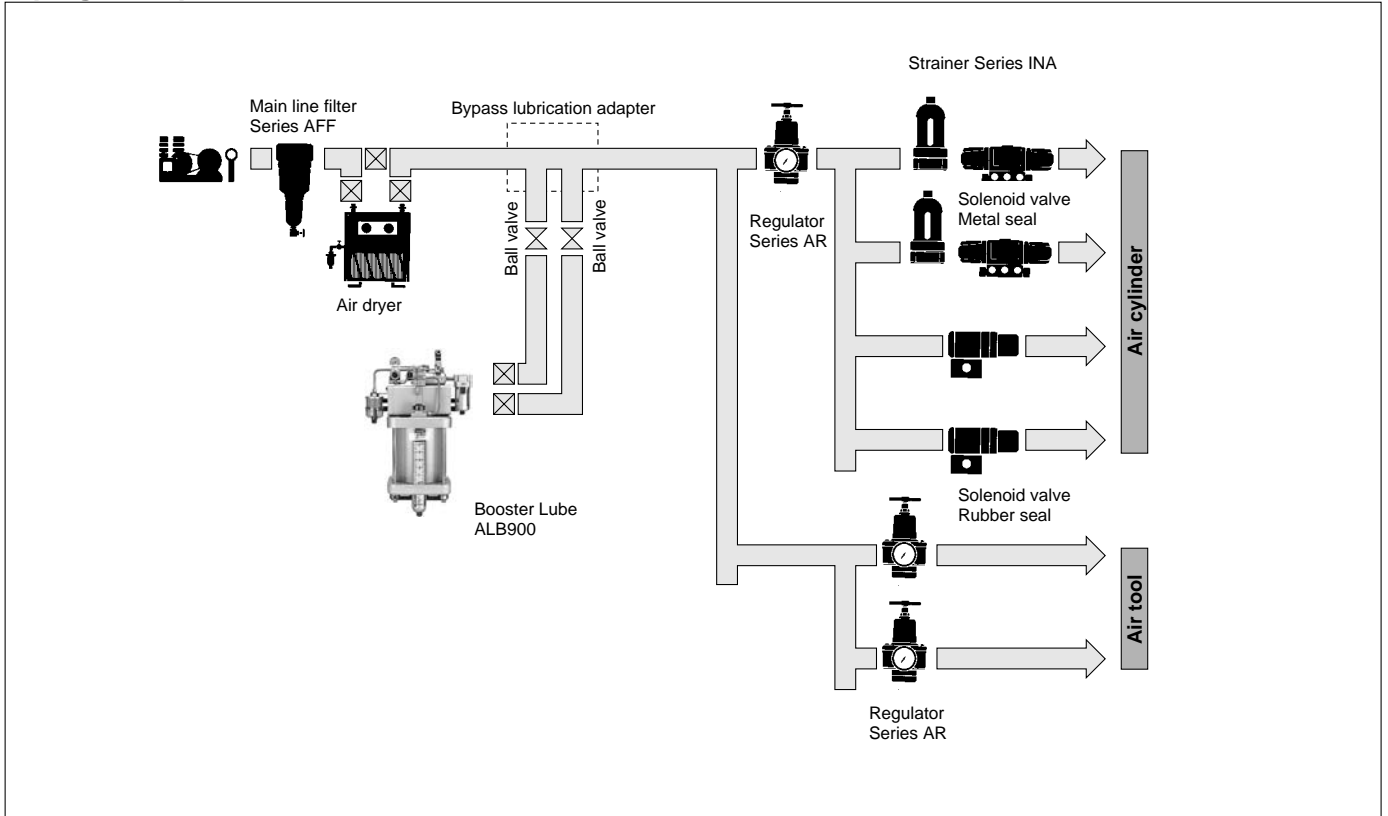

Operation Control Method

As shown in the diagram below, reverse the position of the function plate of the switching valve for operation control, and place it in the NO position or in the unmarked position. When the control signal is input, select the state of the operation or the stopping of the Booster Lube.

NO position Operation at control signal input

Nil position Stop at control signal input

The 100V AC, 200V AC, 220V AC, 24V DC, or air pilot type specification can be applied to the control signal.

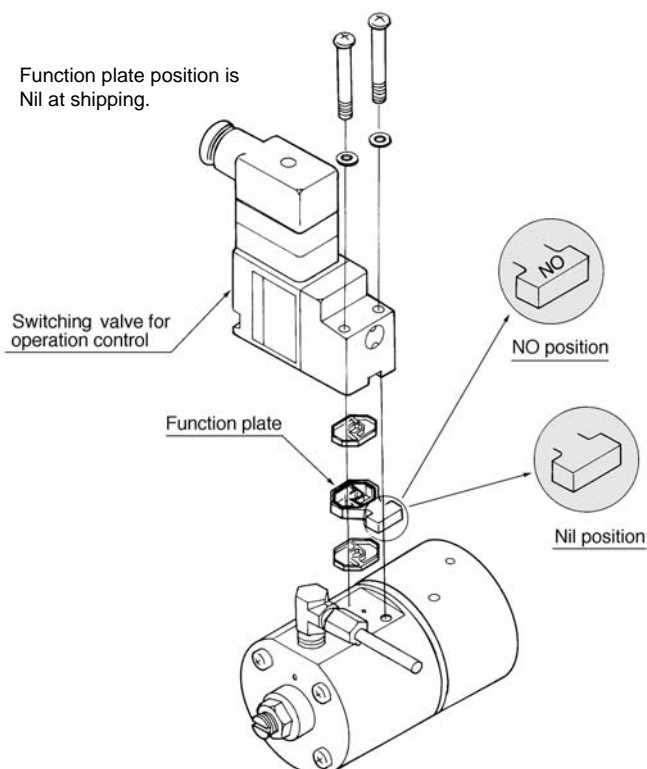

Air Consumption

This unit uses a booster to generate a mist generating pressure differential. Therefore, the booster consumes and discharges the air. Data A indicates the relationship between this air consumption rate, the set pressure differential, and the pressure of the main air passage (primary pressure).

Data A Air consumption

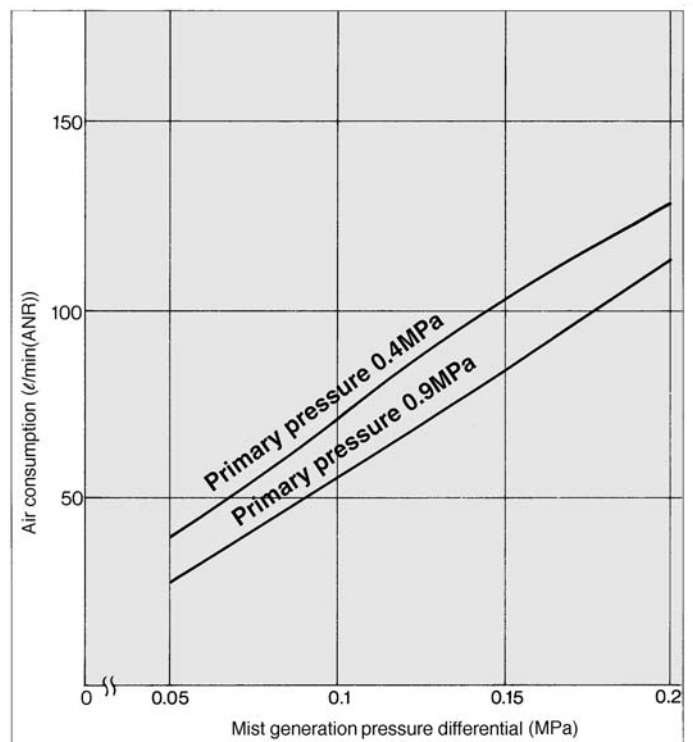

Setting of Mist Generation Pressure Differential

Procedure

- ① Obtain the air consumption flow rate downstream of the Booster Lube.
- ② Obtain the necessary mist generating pressure differential from data B

Data B Flow — Mist generation differential pressure

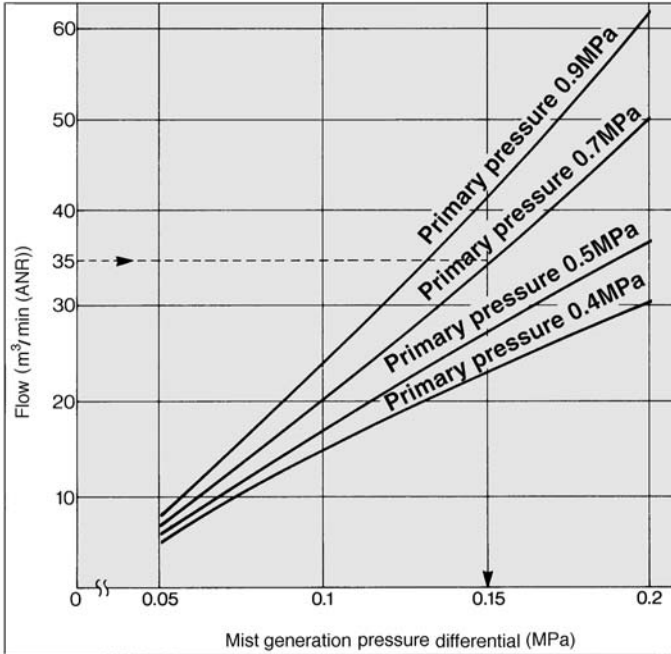

EX: How to obtain the mist generating pressure differential if the flow rate obtained in ① above is 35m³/min and the line pressure (primary pressure P1) is 0.7MPa :

Extend horizontally from the point at which the flow rate is 35m³/min to obtain the point that intersects with P1 = 0.7MPa. Furthermore, extend vertically downward from that point to the point that intersects with the graduation line of the mist generating differential pressure. The value of that intersecting point, which is 0.15MPa, is the mist generating pressure differential that is sought.

- ③ The mist generating pressure differential setting is performed by adjusting the adjustment screw. The pressure differential (the difference between the boost pressure and the line pressure) is increased by turning the adjustment screw clockwise, and decreased it counterclockwise. To check the pressure differential, switch and operate the manual switching valve to read the difference between the boost pressure (high position) and the line pressure (normal position) as shown below (the pressure gauge that is connected to the manual switching valve). After completing the setting, set the manual switching valve to the position of the line pressure indication. Do not set the mist generating pressure differential to exceed 0.2MPa.

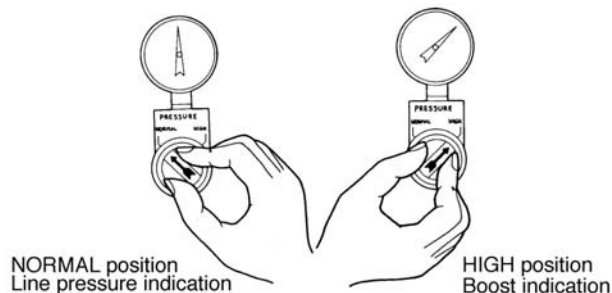
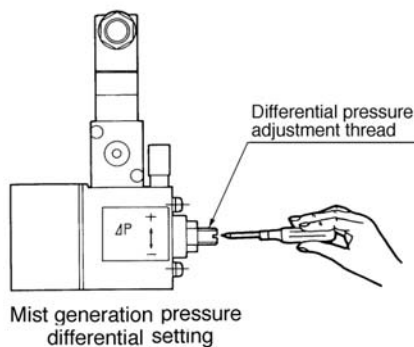

⚠ Precautions

Be sure to read before handling.
Refer to p.0-26 and 0-27 for Safety Instructions and common precautions on the products mentioned in this catalogue, and refer to p.1.0-2 and 1.0-3 for precautions of every series.

Design

⚠ Warning

- ① Epoxy resin containing glass fiber and polycarbonate is used in some parts of the Booster Lube. The Booster Lube cannot be used in an environment or in a location that is exposed to synthetic oil, thinner, acetone, alcohol, organic solvents such as ethylene chloride, chemicals such as sulphuric acid or nitric acid, cutting oil, kerosene, gasoline, or a threadlock agent, etc., because they will be damaged.

Piping

⚠ Warning

If installing an air tank, install it upstream of the bypass oil feed adapter. If it is installed downstream, the micromist could be arrested by the air tank, which could lead to insufficient feeding of oil.

Mounting/Adjustment

⚠ Caution

- ① When setting the pressure differential, if there is a fluctuation in the operating flow rate, set the pressure differential at the higher flow rate range. If it is set in the lower flow rate range, the mist density could become thinner, leading to poor lubrication.
- ② To prevent mist from being generated unnecessarily, if there is no air consumption in the main air passage, operate the switching valve for operation control to stop the operation of the booster.

Maintenance

⚠ Warning

- ① Before removing the oil filler plug, loosen it two and half turns to completely release the pressure in the bowl. This will prevent the oil filler plug from flying out.

AC

AV

AU

AF

AR

IR

VEX

SRP

AW

AMR

AWM

AWD

ITV

VBA

G

AL

ALB900

Construction

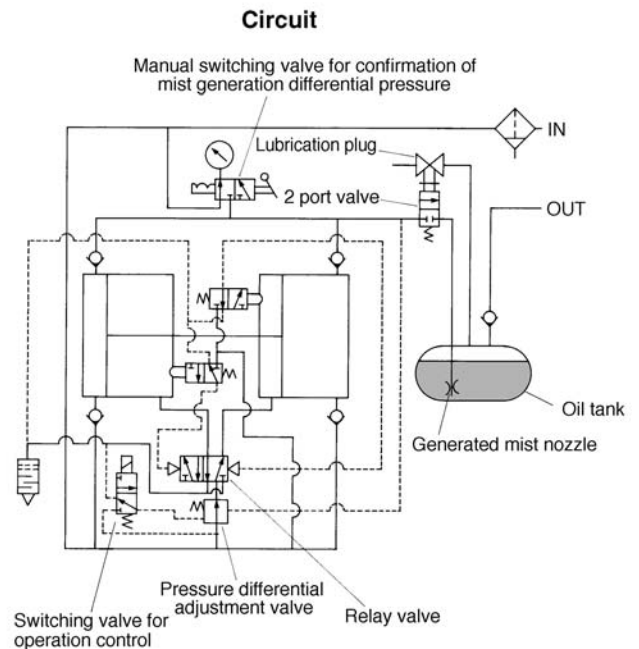
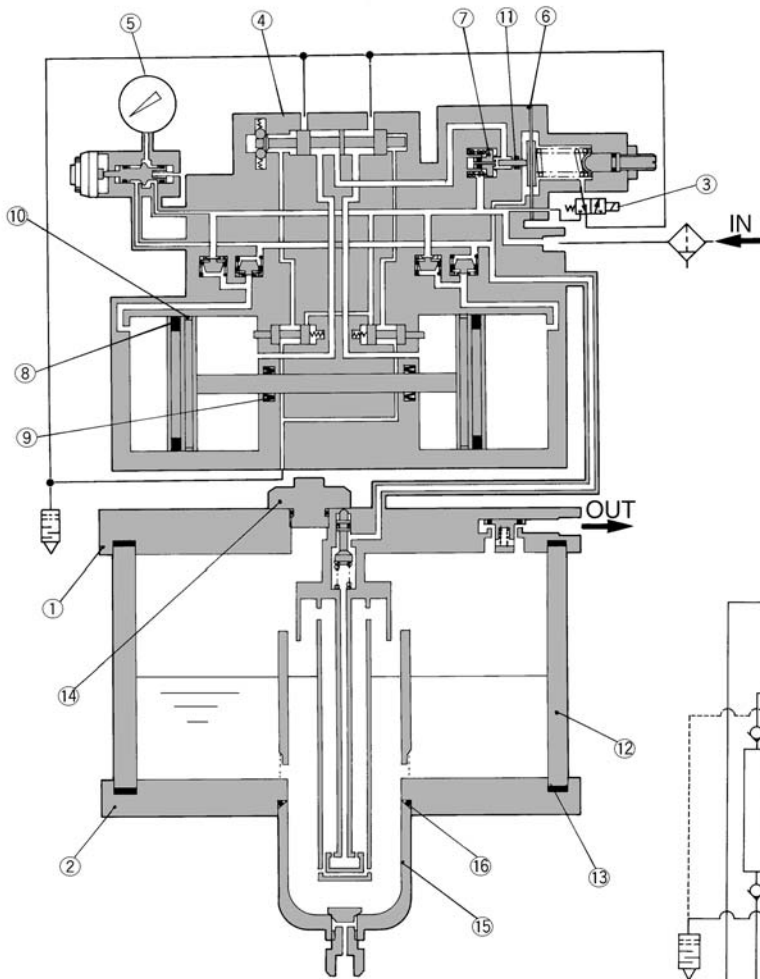

Component parts

No.	Description	Material
①	Top cover	Aluminum die cast
②	Bottom cover	Aluminum die cast

Replacement parts

No.	Description	Material	Part No.	# pieces
③	3 port switching valve (For operation control)	—	VOA301-M VO307E, D-X56*	1
④	Relay valve	—	VR4152-00-0	1
⑤	Pressure gauge	—	GA46-10-01	1
⑥	Diaphragm assembly	—	12702A	1
⑦	Valve assembly	—	12705A	1
⑧	NLP seal	NBR	NLP-100A	2
⑨	PNY seal	NBR	PNY-25	2
⑩	Wear ring	Cloth-inserted phenol aldehyde resin	SW-100 X 6 X 2	2
⑪	O ring	NBR	JIS B2401P3	1
⑫	Bowl assembly	Glass fiber-inserted epoxy resin	126059-4A	1
⑬	Seal	NBR	126060	2
⑭	Lubrication plug assembly	Zinc die cast NBR	126115AP	1
⑮	Bowl assembly	—	AF11-2	1
⑯	O ring	NBR	11307	1

*1: 100V AC, 2: 200V AC, 4: 220V AC, 5: 24V DC, 9: Others

Dimensions

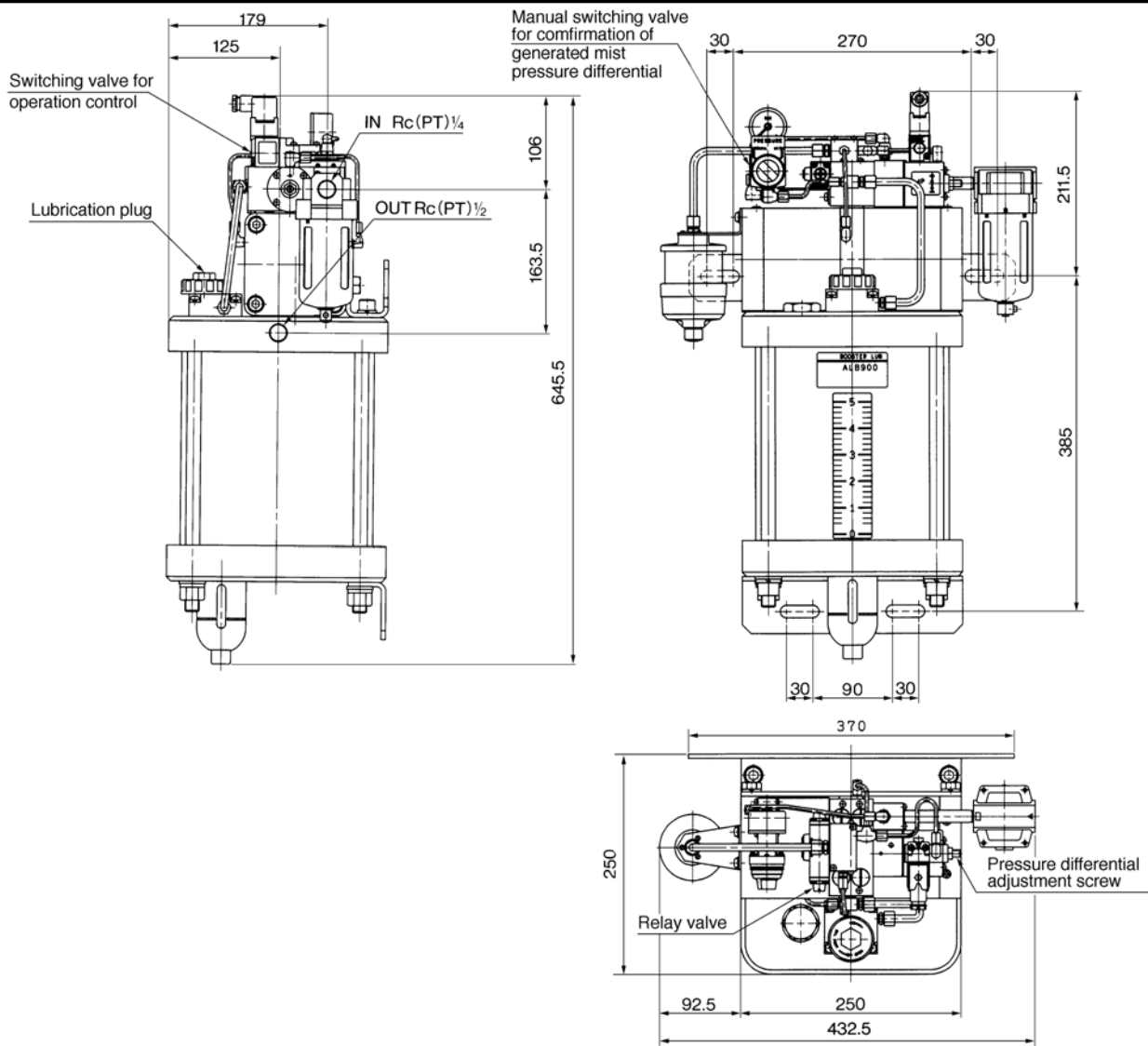

- AC
- AV
- AU
- AF
- AR
- IR
- VEX
- SRP
- AW
- AMR
- AWM
- AWD
- ITV
- VBA
- G
- AL**

By-pass Lubrication Adapter

ALBA90-10, -20

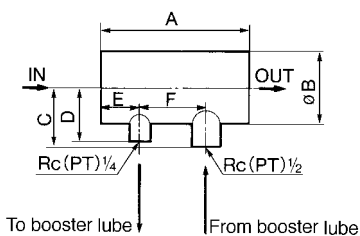

Model No.	Port size Rc(PT)	A	B	C	D	E	F
ALBA90-10	1	150	42.7	45	40	35	80
ALBA90-20	2	165	76.3	65	60	40	80

ALBA90-30

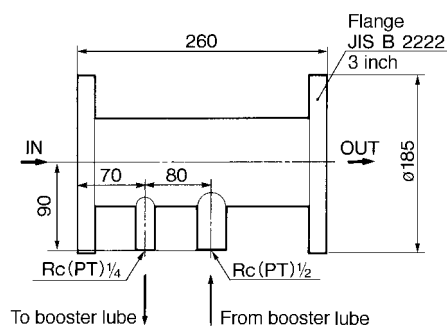

Related equipment/Strainer

At the terminal of an air pressure line in which a D.P. Lube is used, install a strainer (filtration rate of 5µm) upstream from a metal seal solenoid valve, which is susceptible to dust.

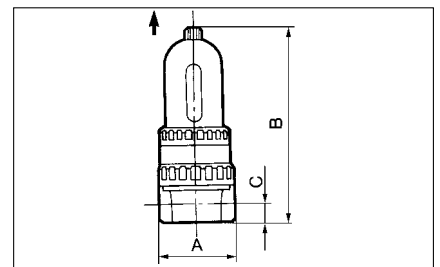

Model No.	Port size Rc(PT)	A	B	C
INA-11-402	1/4	63	141	15
INA-11-403	3/8	63	164.5	15
INA-11-404	1/4, 3/8, 1/2	80	170	15
INA-11-405	3/4	85	180	20
INA-11-406	3/4, 1	90	230	22
INA-11-407	1	100	251	22

