

# Compressed Air Cleaning Filter Series

## For Water, Solid/Oil Separation and Deodorization

**Modular connection, Space-saving design, Labor-saving in piping!** (AMG□□, AFF□□, AM□□, AMD□□)  
(AMH□□, AME□□, AMF□□)

Uses the same spacer as the F.R.L. combination AC series.  
Possible to make a modular connection with products such as AR series regulator.

### Modular connection example

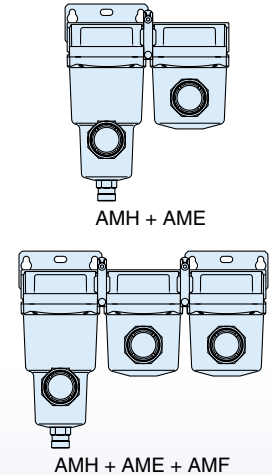

\* The C type is only suitable for modular connection.

### Options added (AMG□□, AFF□□, AM□□, AMD□□) (AMH□□, AME□□, AMF□□)

Addition: **5** types

- 1.6 MPa specifications
- Fluororubber specifications
- With differential pressure switch (30 VDC)
- Degreasing wash, white vaseline specifications

Differential pressure switch



### Compact, Lightweight (AME□□, AMF□□)

Height and mass reduced by up to **40%**

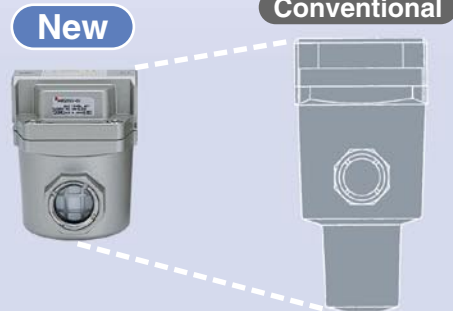

#### Water Separation

Water Separator/**AMG**

#### Solid/Oil Separation

Main Line Filter/**AFF**

Mist Separator/**AM**

Micro Mist Separator/**AMD**

Micro Mist Separator with Pre-filter/**AMH**

Super Mist Separator/**AME**

#### Deodorization

Odour Removal Filter/**AMF**

Series **AM□/AFF**



CAT.EUS30-11A-UK

## Water droplet removal

### Water Separator

Water droplet separation rate: 99%



AMG150C to 550C    AMG650/850

Model	Flow capacity ℓ/min (ANR) Max. flow capacity at 0.7 MPa inlet pressure	Port size	
AMG	150C	300	1/8, 1/4
	250C	750	1/4, 3/8
	350C	1,500	3/8, 1/2
	450C	2,200	1/2, 3/4
	550C	3,700	3/4, 1
	650	6,000	1, 1 1/2
	850	12,000	1 1/2, 2

## Large dust particle filtration, Oil droplet separation

### Main Line Filter

Nominal filtration rating: 3 μm  
[Filtration efficiency: 99%]



AFF2C to 22C    AFF37B/75B

AFF	2C	300	1/8, 1/4
	4C	750	1/4, 3/8
	8C	1,500	3/8, 1/2
	11C	2,200	1/2, 3/4
	22C	3,700	3/4, 1
	37B	6,000	1, 1 1/2
	75B	12,000	1 1/2, 2

## Dust filtration, Oil mist separation

### Mist Separator

Nominal filtration rating: 0.3 μm  
[Filtration efficiency: 99.9%]  
Oil mist density at outlet:  
Max. 1.0 mg/m<sup>3</sup> (ANR)  
[≈0.8 ppm]



AM150C to 550C    AM650/850

AM	150C	300	1/8, 1/4
	250C	750	1/4, 3/8
	350C	1,500	3/8, 1/2
	450C	2,200	1/2, 3/4
	550C	3,700	3/4, 1
	650	6,000	1, 1 1/2
	850	12,000	1 1/2, 2

## Dust filtration, Oil mist separation

### Micro Mist Separator

Nominal filtration rating: 0.01 μm  
[Filtration efficiency: 99.9%]  
Oil mist density at outlet:  
Max. 0.1 mg/m<sup>3</sup> (ANR)  
[≈0.08 ppm]



AMD150C to 550C    AMD650 to 850

AMD	150C	200	1/8, 1/4
	250C	500	1/4, 3/8
	350C	1,000	3/8, 1/2
	450C	2,000	1/2, 3/4
	550C	3,700	3/4, 1
	650	6,000	1, 1 1/2
	850	12,000	1 1/2, 2

## Dust filtration, Oil mist separation

### Micro Mist Separator with Pre-filter

Built-in 0.3 μm pre-filter  
 The AM + AMD element have been integrated to achieve a space-saving design.  
 Nominal filtration rating: 0.01 μm  
 [Filtration efficiency: 99.9%]  
 Oil mist density at outlet:  
 Max. 0.1 mg/m<sup>3</sup> (ANR)  
 [≈0.08 ppm]



AMH150C to 550C AMH650/850

Model	Flow capacity ℓ/min (ANR) Max. flow capacity at 0.7 MPa inlet pressure	Port size	
AMH	150C	200	1/8, 1/4
	250C	500	1/4, 3/8
	350C	1,000	3/8, 1/2
	450C	2,000	1/2, 3/4
	550C	3,700	3/4, 1
	650	6,000	1, 1 1/2
	850	12,000	1 1/2, 2

## Dust filtration, Oil mist adsorption

### Super Mist Separator

Colour change indicates when element is saturated.  
 Nominal filtration rating: 0.01 μm  
 [Filtration efficiency: 99.9%]  
 Oil mist density at outlet:  
 Max. 0.01 mg/m<sup>3</sup> (ANR)  
 [≈0.008 ppm]  
 Cleanliness at outlet:  
 Not more than 35  
 particles of size  
 0.3 μm or larger/10 ℓ  
 (100 particles or less/ft<sup>3</sup>)



AME150C to 550C AME650/850

AME	150C	200	1/8, 1/4
	250C	500	1/4, 3/8
	350C	1,000	3/8, 1/2
	450C	2,000	1/2, 3/4
	550C	3,700	3/4, 1
	650	6,000	1, 1 1/2
	850	12,000	1 1/2, 2

## Deodorization

### Odour Removal Filter

Nominal filtration rating: 0.01 μm  
 [Filtration efficiency: 99.9%]  
 Oil mist density at outlet:  
 Max. 0.004 mg/m<sup>3</sup> (ANR)  
 [≈0.0032 ppm]



AMF150C to 550C AMF650 to 850

AMF	150C	200	1/8, 1/4
	250C	500	1/4, 3/8
	350C	1,000	3/8, 1/2
	450C	2,000	1/2, 3/4
	550C	3,700	3/4, 1
	650	6,000	1, 1 1/2
	850	12,000	1 1/2, 2

# Compressed Air Cleaning Filter Series

## Series AM□/AFF

	Series	Water removal rate	Nominal filtration rating	Oil mist density at outlet	Smell	Page
<b>Water Separator</b>	<b>Series AMG</b> Eliminates water droplets in the compressed air.	99%	—	—	—	P.2
<b>Solid/Oil Separator</b>	<b>Series AFF</b> Eliminates impurities such as oil and foreign matter, etc. in compressed air.	—	3 µm (Filtration efficiency: 99%)	—	—	P.10
	<b>Series AM</b> Eliminates oil mist in compressed air or rust sized 0.3 µm or more, and foreign matter such as carbon.		0.3 µm (Filtration efficiency: 99.9%)	1 mg/m <sup>3</sup> (ANR) (≈0.8 ppm) (after oil saturation)		P.18
	<b>Series AMD</b> Eliminates foreign matter sized 0.01 µm or more, or oil particles in an aerosol state.		0.01 µm (Filtration efficiency: 99.9%)	0.1 mg/m <sup>3</sup> (ANR) (≈0.08 ppm) (after oil saturation)		P.26
	<b>Series AMH</b> Oil separator, which incorporates pre-filter (equivalent to the AM series) into micro mist separator.		0.3 + 0.01 µm (Filtration efficiency: 99.9%)	Reduces oil smell.		P.34
	<b>Series AME</b> Captures foreign matter sized 0.01 µm or more and adsorbs oil particles in an aerosol state.		0.01 µm (Filtration efficiency: 99.9%)			0.01 mg/m <sup>3</sup> (ANR) (≈0.008 ppm)
<b>Deodorizer</b>	<b>Series AMF</b> Eliminates odour from compressed air.		0.004 mg/m <sup>3</sup> (ANR) (≈0.0032 ppm)	Deodorizes oil smell.	P.50	
<b>Modular Connection Examples</b>						P.58
<b>How to Order Bowl Assembly</b>						P.59
<b>Options</b>	<ul style="list-style-type: none"> <li>Seal material: Fluororubber</li> <li>IN-OUT reversal direction</li> <li>Degreasing wash, white vaseline</li> <li>For medium air pressure</li> <li>Drain guide 1/4 female threaded</li> <li>With element service indicator</li> <li>With differential pressure switch (with indicator) (125 VAC, 30 VDC)</li> <li>With differential pressure switch (with indicator) (30 VDC)</li> </ul>					Refer to "How to Order" of respective models.
<b>Made to Order</b>	<ul style="list-style-type: none"> <li>With differential pressure gauge Possible to control product's service life by monitoring the clogged element.</li> <li>Auto drain type, drain guide specifications Drain piping is possible by auto drain type.</li> <li>White vaseline specifications* Using white vaseline for lubricant.</li> </ul>					P.63
* Applicable only to the AFF37B, 75B, AM□650 and 850.						
<b>Special Specifications</b>	<b>Clean Series</b> Usable inside a clean room.	<b>Copper-free, Fluorine-free</b> Eliminates the effects on a colour CRT by copper ion or fluoric resin, etc.			P.63	
<b>Related Products</b>	Auto Drain Valve, Motor Operated Auto Drain, Heavy Duty Auto Drain, Differential Pressure Gauge					P.67
<b>Specific Product Precautions</b>						Back page 3
<b>Discontinued Model and Equivalent Model</b>						Back page 7

# Water Separator Series AMG

Can remove water droplets in compressed air. Use this product in cases where “water must be avoided, but not so dry as when an air dryer is used”.

Through the adoption of an element that is exclusively used for removing water droplets and the ample housing interior space, a 99%\* water removal rate\*\* has been achieved.

## ⚠ Caution

Water separator can remove water droplets, but it cannot remove moisture.

\* Condition of inlet air  
 { Pressure: 0.7 MPa  
 Temperature: 25°C  
 Relative humidity: 100%  
 Liquid water content (Water droplet content): 15 g/m<sup>3</sup> (ANR)  
 Compressed air flow: Rated flow of each model

\*\* Water removal rate (%) =  $\frac{\text{Removed water (Water droplet) (g)}}{\text{Inflowed water (Water droplet) (g)}} \times 100$

Modular connection is possible with AMG150C to 550C.  
 (For details, refer to page 58.)



AMG150C to 550C



AMG650/850

Symbol

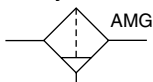

(For drain cock)



(For auto drain)



Made to Order

(For details, refer to page 63.)

## Model

Model	AMG150C	AMG250C	AMG350C	AMG450C	AMG550C	AMG650	AMG850
Rated flow (ℓ/min (ANR)) <small>Note</small>	300	750	1500	2200	3700	6000	12000
Port size	1/8, 1/4	1/4, 3/8	3/8, 1/2	1/2, 3/4	3/4, 1	1, 1 1/2	1 1/2, 2
Mass (kg)	0.38	0.55	0.9	1.4	2.1	4.2	10.5



Note) Max. flow at 0.7 MPa.

Max. flow varies depending on the operating pressure. Refer to “Flow Characteristics” (page 5) and “Maximum Air flow” (page 6).

## Specifications

Fluid	Compressed air
Max. operating pressure	1.0 MPa
Min. operating pressure*	0.05 MPa
Proof pressure	1.5 MPa
Ambient and fluid temperature	5 to 60°C
Water removal rate	99%
Element life	2 years or when pressure drop reached 0.1 MPa

\* With auto drain: 0.1 MPa (N.O. type) or 0.15 MPa (N.C. type)

## Accessory

Applicable model	AMG150C	AMG250C	AMG350C	AMG450C	AMG550C	AMG650	AMG850
Bracket assembly (with 2 mounting screws)	AM-BM101	AM-BM102	AM-BM103	AM-BM104	AM-BM105	BM56	BM57

## ⚠ Caution

Be sure to read this before handling.

Refer to back pages 1 and 2 for Safety Instructions, “Precautions for Handling Pneumatic Devices” (M-03-E3A) for Common Precautions, and back pages 3 through to 7 for Specific Product Precautions.

## How to Order



### AMG150C to 550C

AMG **550C** - [ ] **10** [ ] [ ] - [ ] - [ ]

#### Body size

150C
250C
350C
450C
550C

#### Thread type

Symbol	Type
—	Rc
<b>F</b>	G*1
<b>N</b>	NPT

\*1 Conforms to ISO1179-1.

#### Port size

Symbol	Size	Applicable body size				
		150C	250C	350C	450C	550C
01	1/8	●				
02	1/4	●	●			
03	3/8		●	●		
04	1/2			●	●	
06	3/4				●	●
10	1					●

#### Accessory

Symbol	Description
—	—
<b>B</b>	Bracket *2

\*2 Bracket is included, (but not assembled).

#### Made to Order

("How to Order" and the applicable models are different from those shown on this page. Be sure to refer to "Made to Order".)

Symbol	Description	Page for details
—	—	—
<b>X26</b>	N.C., N.O. auto drain, drain piping type	P.65

#### Option \*3

Symbol	Description
—	—
<b>F</b>	Rubber material: Fluororubber
<b>H</b>	For medium air pressure (1.6 MPa)
<b>J</b>	Drain guide 1/4 female threaded *4
<b>R</b>	IN-OUT reversal direction
<b>V</b>	Degreasing wash, *5 white vaseline

\*4 Drain piping and piping for a stop valve such as ball valve are required.

\*5 Only body/housing is degreasing washed.

#### Auto drain \*3

Symbol	Description
—	Drain cock (Without auto drain)
<b>C</b>	N.C. auto drain
<b>D</b>	N.O. auto drain

\*3 Refer to the table below for the combination between the draining specification and option. (Only one draining specification is selectable).

#### Auto Drain Specifications/Option Combinations

◎: All draining specifications are available (including drain guide, J type).

△: N.C. auto drain (C type) is not available.

▼: N.C. auto drain (C type) and N.O. auto drain (D type) are not available.

	—	F	H	R	V
—	◎	◎	△	◎	◎
F	◎	◎	▼	◎	▼
H	△	▼	■	△	▼
R	◎	◎	△	■	◎
V	◎	▼	▼	◎	■

■: Not available

## Options

#### Symbol F: Rubber material: Fluororubber

Fluororubber is used for the parts such as O-ring and gasket.

#### Symbol H: For medium air pressure (1.6 MPa)

Can be used up to 1.6 MPa at maximum.

#### Symbol J: Drain guide 1/4 female threaded

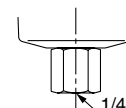

Can be piped to the drain exhaust port.

1/4 female threaded

#### Symbol R: IN-OUT reversal direction

Air flow in the separator is changed to right to left.  
(Air flow direction of the standard: Left to right.)

#### Symbol V: Degreasing wash, white vaseline

Body/housing is degreasing washed. The lubrication grease for O-ring and gasket is changed to white vaseline.



## How to Order

### AMG650/850

AMG **650** - [ ] **10** [ ] [ ] - [ ] - [ ]

**Body size**

650
850

**Thread type**

Symbol	Type
—	Rc
<b>F</b>	G
<b>N</b>	NPT

**Port size**

Symbol	Size	Applicable body size	
		650	850
<b>10</b>	1	●	—
<b>14</b>	1 1/2	●	●
<b>20</b>	2	—	●

**Accessory**

Symbol	Description
—	—
<b>B</b>	Bracket *1

\*1 Bracket is included, (but not assembled).

**Made to Order**

("How to Order" and the applicable models are different from those shown on this page. Be sure to refer to "Made to Order".)

Symbol	Description	Page for details
—	—	—
<b>X26</b>	N.C., N.O. auto drain, drain piping type	P.65
<b>X12</b>	White vaseline	P.65

**Option \*2**

Symbol	Description
—	—
<b>J</b>	Drain guide 1/4 female threaded *4
<b>R</b>	IN-OUT reversal direction

\*4 Drain piping and piping for a stop valve such as ball valve are required.

Note) Element service indicator (symbol: T) is not available as an option because water deposits inside the indicator could lead to malfunctions.

**Auto drain \*2**

Symbol	Description
—	Drain cock (Without auto drain) *3
<b>D</b>	N.O. auto drain

\*2 Refer to "Auto Drain Specifications/Option Combinations".

\*3 Body size 850 is equipped with a ball valve (Rc3/8 female threaded). Mount a piping adapter IDF-AP609 (page 58) to the ball valve if NPT3/8 female threaded is required.



Note) Refer to "How to Order Bowl Assembly" on page 63.

### Auto Drain Specifications/Option Combinations

○ : Available    □ : Not available

Auto drain specifications/Option			Auto drain specifications		Option		Applicable model	
			D	J	R	AMG650	AMG850	
Auto drain specifications	N.O. auto drain	<b>D</b>	□	□	○	○	○	
	Drain guide 1/4	<b>J</b>	□	□	○	○	□	
Option	IN-OUT reversal direction	<b>R</b>	○	○	□	○	○	

# Series AMG

## Flow Characteristics



Note) Compressed air over max. flow line in the table below may not meet the specifications of the product. It may cause damage to the element.

**AMG150C**

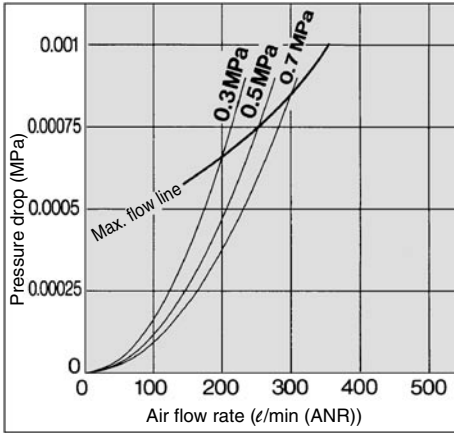

**AMG450C**

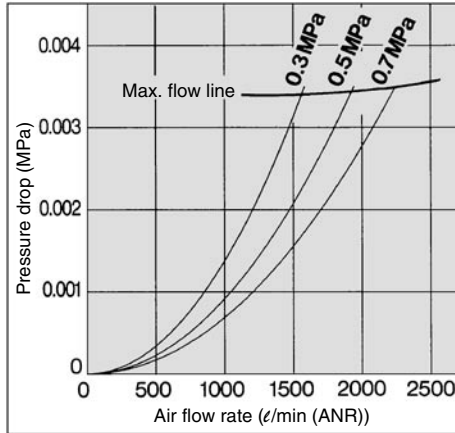

**AMG850**

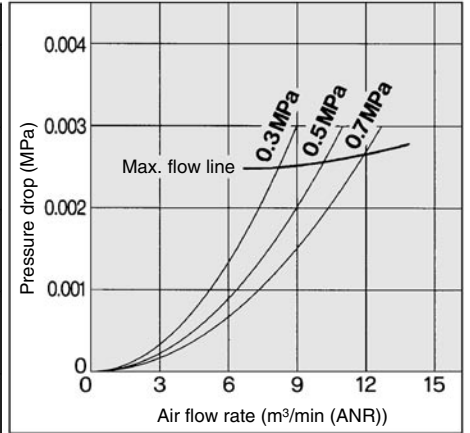

**AMG250C**

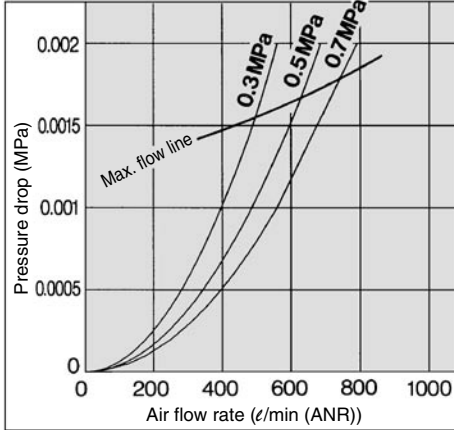

**AMG550C**

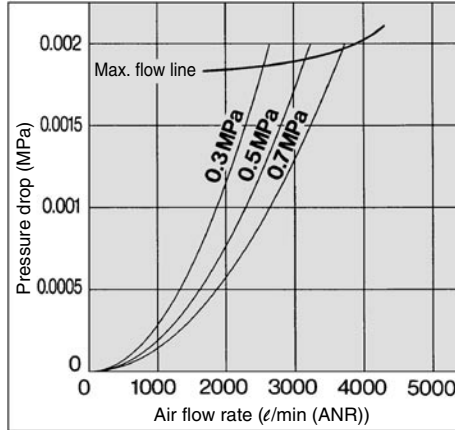

**AMG350C**

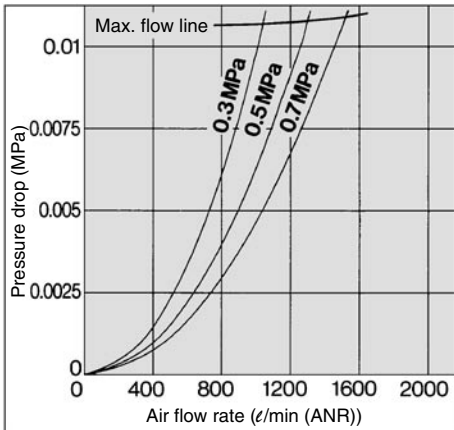

**AMG650**

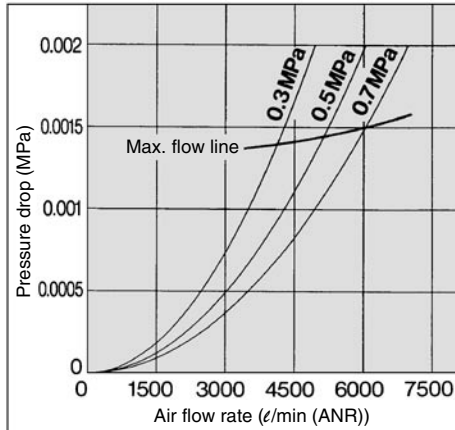



## Construction

### AMG150C to 550C, AMG650

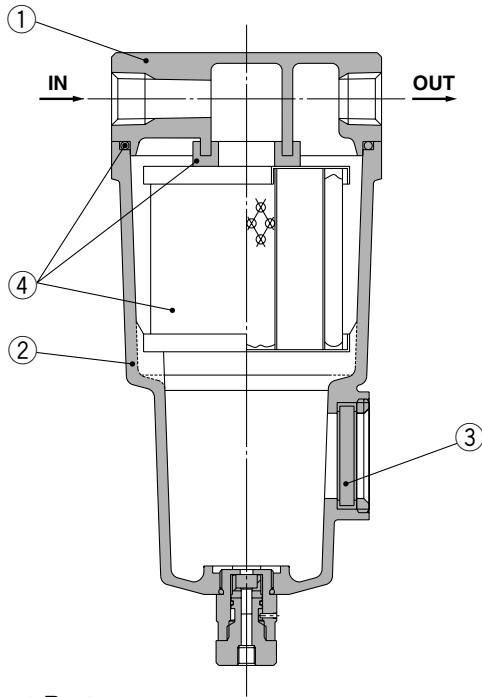

### AMG850

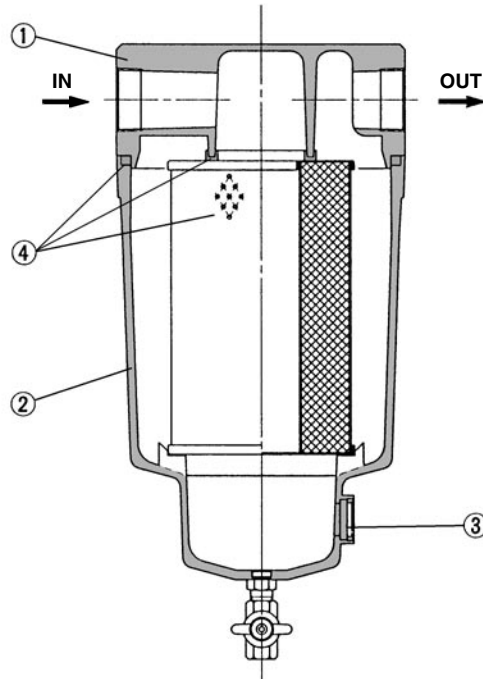

## Component Parts

No.	Description	Material	Note
1	<b>Body</b>	Aluminum die-casted	Chrome treated Epoxy coating on inner surface
2	<b>Housing</b>	Aluminum die-casted*	
3	<b>Sight glass</b>	Tempered glass	—

\* The AMG850 is aluminum casted.



Note) Refer to "How to Order Bowl Assembly" on page 59.



Note) Sight glass is indicated in the figure for easy understanding of component parts. However, it differs from the actual construction. Refer to dimensions on pages 7 through to 9 for details.

## Replacement Parts

No.	Description	Material	Applicable model	Model						
				AMG150C	AMG250C	AMG350C	AMG450C	AMG550C	AMG650	AMG850
4	<b>Element assembly</b>	Resin, others	Except option F	AMG-EL150	AMG-EL250	AMG-EL350	AMG-EL450	AMG-EL550	AMG-EL650	AMG-EL850
			For option F	AMG-EL150-F	AMG-EL250-F	AMG-EL350-F	AMG-EL450-F	AMG-EL550-F	—	—

\* Element assembly: With gasket (1 pc.) and O-ring (1 pc.)

\* Refer to back page 6 for replacement of auto drain.

\* Element assemblies for Made to Order (X12, X20, X26) are same as those for standard (see the above table).

## Maximum Air Flow

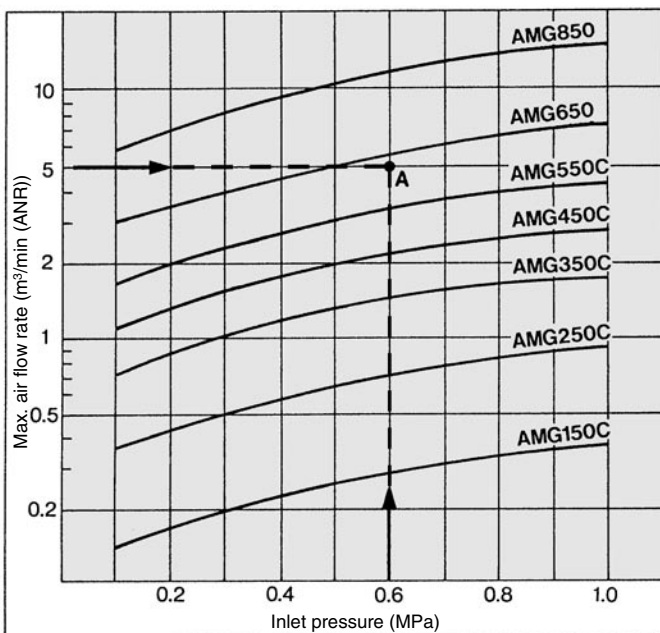

## Model Selection

Select a model in accordance with the following procedure taking the inlet pressure and the max. air flow rate into consideration.

(Example) Inlet pressure: 0.6 MPa

Max. air flow rate: 5 m<sup>3</sup>/min (ANR)

1. Obtain the intersecting point A of inlet pressure and max. air flow rate in the graph.
2. The AMG650 is obtained when the max. flow line is above the intersecting point A in the graph.



Note) Make sure to select a model that has the max. flow line above the obtained intersecting point. With a model that has the max. flow line below the obtained intersecting point, the flow rate will be exceeded, thus leading to a problem such as being unable to satisfy the specifications.

# Series AMG

## Dimensions

### AMG150C to 550C

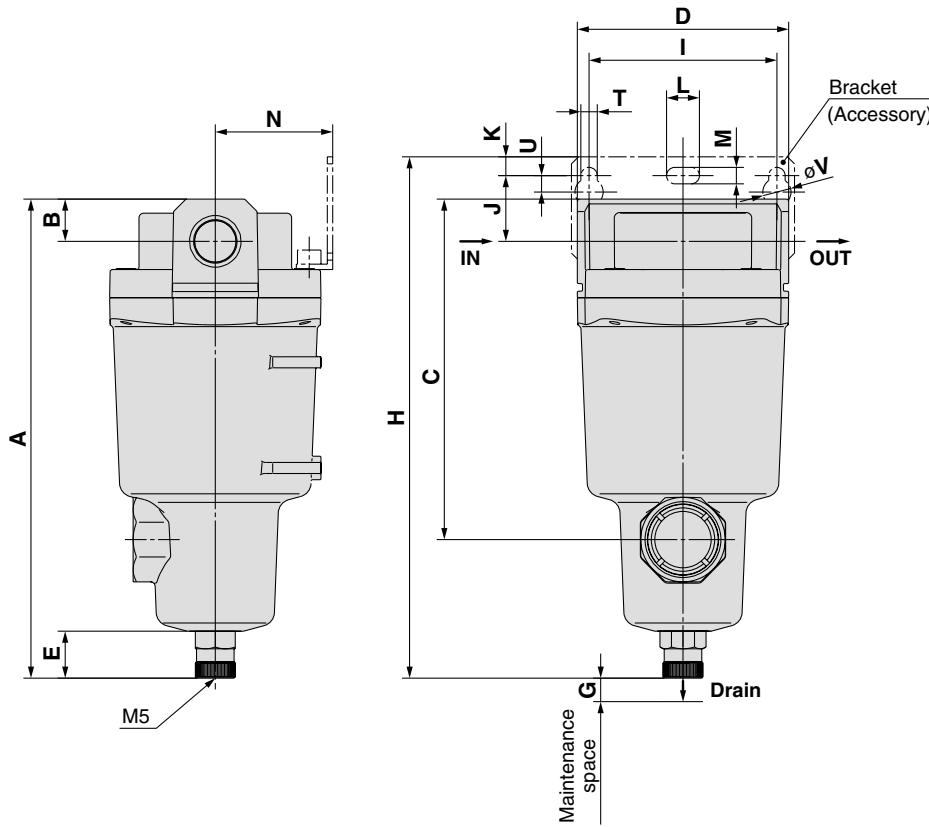
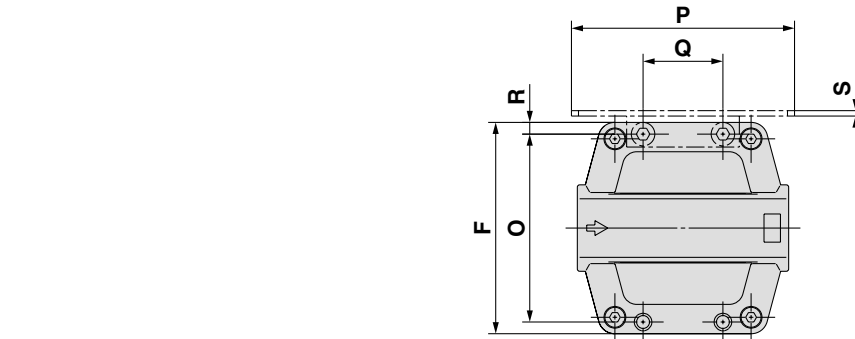

### Auto drain

C: With auto drain (N.C.)  
D: With auto drain (N.O.)

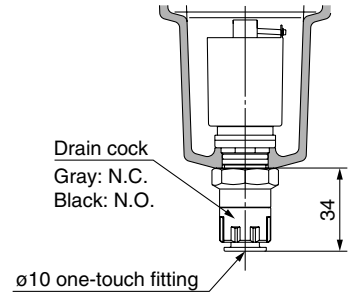

Combination of D: With auto drain (N.O.)  
and H: For medium air pressure

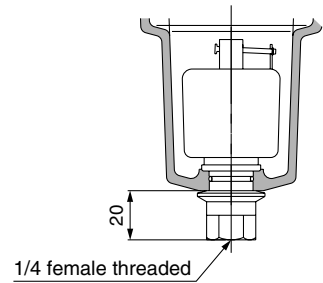

### Option

J: Drain guide 1/4 female threaded

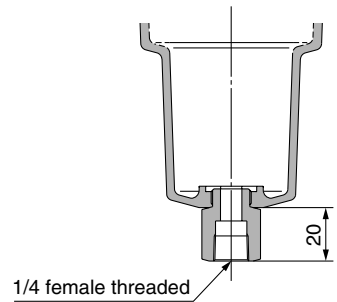

Model	Port size	A	B	C	D	E	F	G	Bracket related dimensions														
									H	I	J	K	T	U	L	M	V	N	O	P	Q	R	S
AMG150C	1/8, 1/4	158	10	99	63	20	63	10	173	56	20	5	6	6	12	6	10	35	54	70	26	4.5	1.6
AMG250C	1/4, 3/8	172	14	113	76	20	76	10	190	66	24	8	6	6	12	6	10	40	66	80	28	5	2
AMG350C	3/8, 1/2	204	18	145	90	20	90	10	222	80	28	8	7	7	14	7	12	50	80	95	34	5	2.3
AMG450C	1/2, 3/4	225	20	166	106	20	106	10	246	90	31	10	9	9	18	9	15	55	88	111	50	9	3.2
AMG550C	3/4, 1	259	24	200	122	20	122	15	278	100	33	10	9	9	18	9	15	65	102	126	60	10	3.2

(mm)

**Dimensions**

**AMG650**

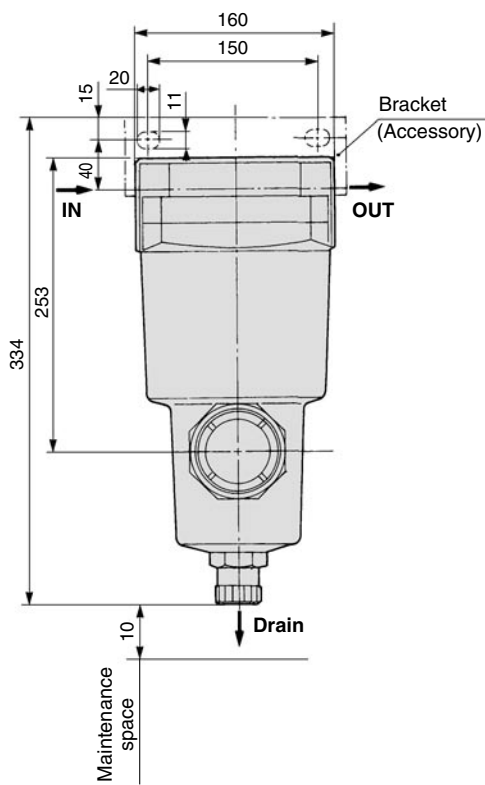
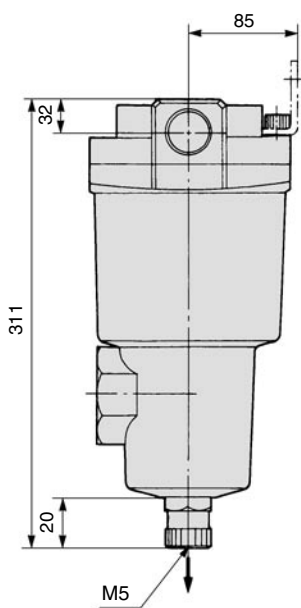
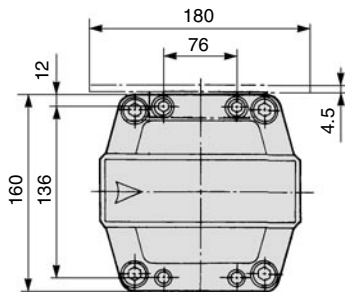

**Auto drain**

**D: With auto drain (N.O.)**

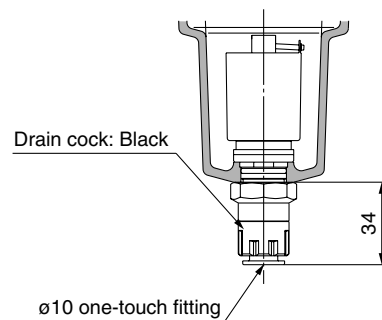

**Option**

**J: Drain guide 1/4 female threaded**

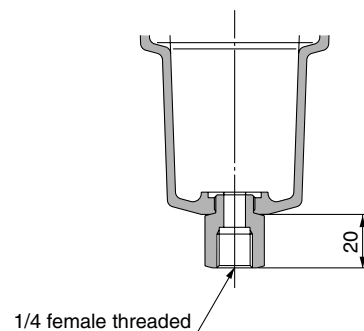

# Series AMG

## Dimensions

### AMG850

#### Auto drain

D: With auto drain (N.O.)  
for AMG850

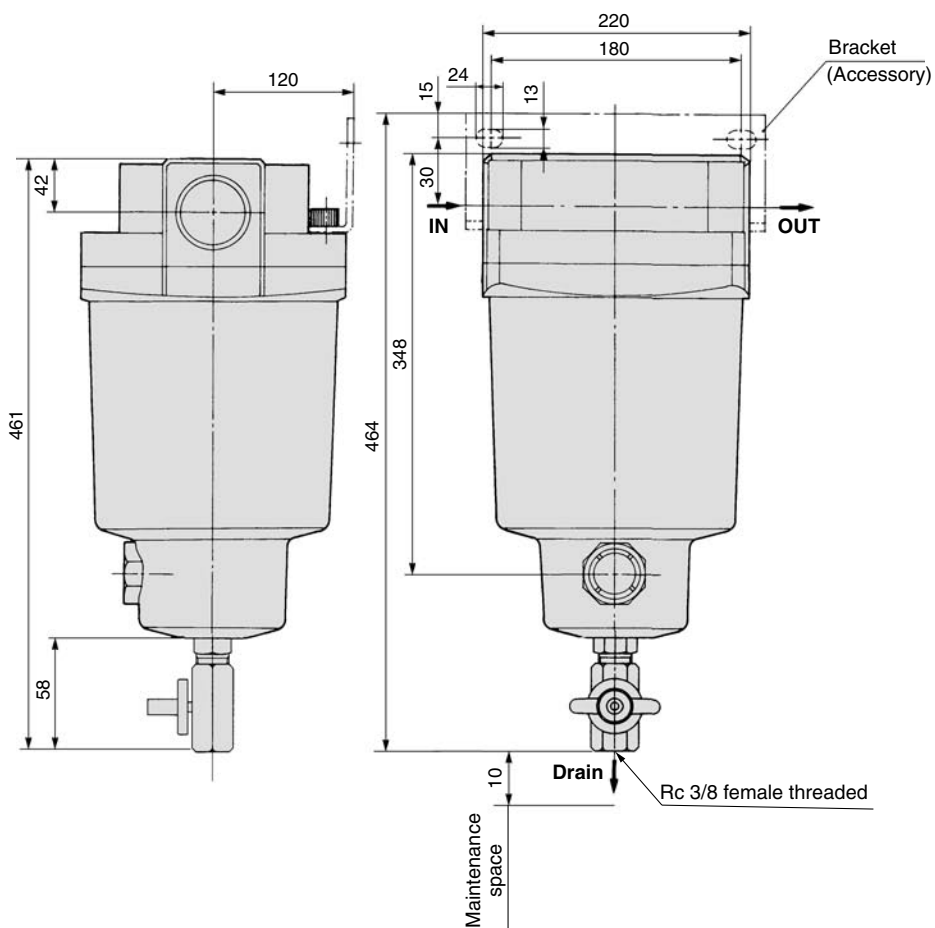
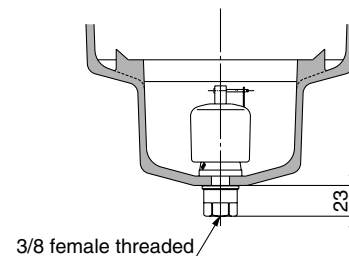
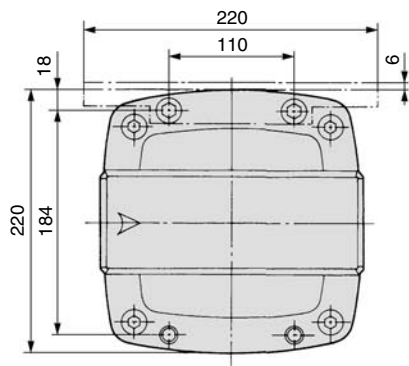

# Main Line Filter

## Series AFF

Can remove impurities such as oil, water and foreign matter in compressed air and can improve the function of a dryer in the downstream, extend the life of precision filter, and prevent trouble with the equipment.

Modular connection is possible with AFF2C to 22C.

(For details, refer to page 58.)



AFF2C to 22C



AFF37B/75B

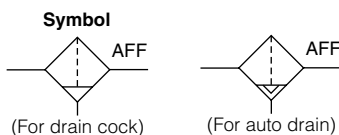

**Made to Order**  
(For details, refer to page 63.)

### Caution

Be sure to read this before handling.  
Refer to back pages 1 and 2 for Safety Instructions, "Precautions for Handling Pneumatic Devices" (M-03-E3A) for Common Precautions, and back pages 3 through to 7 for Specific Product Precautions.

### Model

Model	AFF2C	AFF4C	AFF8C	AFF11C	AFF22C	AFF37B	AFF75B
Rated flow <sup>Note)</sup> ( $\text{d}/\text{min}$ (ANR))	300	750	1500	2200	3700	6000	12000
Port size	$1/8, 1/4$	$1/4, 3/8$	$3/8, 1/2$	$1/2, 3/4$	$3/4, 1$	$1, 1 1/2$	$1 1/2, 2$
Mass (kg)	0.38	0.55	0.9	1.4	2.1	4.2	10.5



Note) Max. flow at 0.7 MPa.

Max. flow varies depending on the operating pressure.

Refer to "Flow Characteristics" (page 13) and "Maximum Air Flow" below.

### Specifications

Fluid	Compressed air
Max. operating pressure	1.0 MPa
Min. operating pressure*	0.05 MPa
Proof pressure	1.5 MPa
Ambient and fluid temperature	5 to 60°C
Nominal filtration rating	3 $\mu\text{m}$ (Filtration efficiency: 99%)
Element life	2 years (1 year for A type) or when pressure drop reached 0.1 MPa

\* With auto drain: 0.1 MPa (N.O. type) or 0.15 MPa (N.C. type)

### Accessory/For AFF2C to 22C, AFF37B/75B

Applicable model	AFF2C	AFF4C	AFF8C	AFF11C	AFF22C	AFF37B	AFF75B
Bracket assembly (with 2 mounting screws)	AM-BM101	AM-BM102	AM-BM103	AM-BM104	AM-BM105	BM56	BM57

### Model Selection

Select a model in accordance with the following procedure taking the inlet pressure and the max. air flow rate into consideration.  
(Example) Inlet pressure: 0.6 MPa  
Max. air flow rate: 5  $\text{m}^3/\text{min}$  (ANR)

1. Obtain the intersecting point A of inlet pressure and max. air flow rate in the graph.
2. The AFF37B is obtained when the max. flow line is above the intersecting point A in the graph.



Note) Make sure to select a model that has the max. flow line above the obtained intersecting point. With a model that has the max. flow line below the obtained intersecting point, the flow rate will be exceeded, thus leading to a problem such as being unable to satisfy the specifications.

### Maximum Air Flow

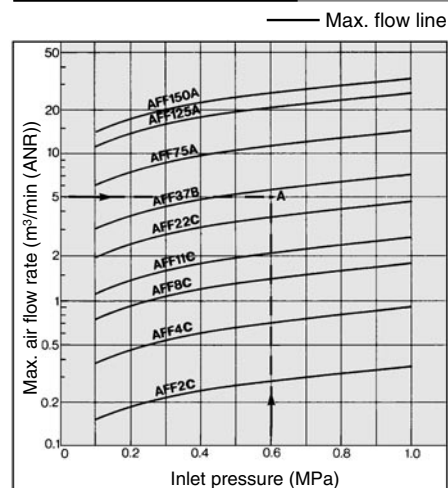

## How to Order



### AFF22C to 22C

**AFF 22C** - [ ] - [ ] - [ ] - [ ] - [ ]

**Body size**

Symbol	Applicable compressor output (guide)
2C	2.2 kW
4C	3.7 kW
8C	7.5 kW
11C	11 kW
22C	22 kW

**Thread type**

Symbol	Type
—	Rc
F	G*1
N	NPT

\*1 Conforms to ISO1179-1.

**Port size**

Symbol	Size	Applicable body size				
		2C	4C	8C	11C	22C
01	1/8	●				
02	1/4	●	●			
03	3/8		●	●		
04	1/2			●	●	
06	3/4				●	●
10	1					●

**Accessory**

Symbol	Description
—	—
B	Bracket *2

\*2 Bracket is included, (but not assembled).

### Auto Drain Specifications/Option Combinations

- : All draining specifications are available (including drain guide, J type).
- △ : N.C. auto drain (C type) is not available.
- ▼ : N.C. auto drain (C type) and N.O. auto drain (D type) are not available.

	—	F	H	R	S	U	T	V
—	○	○	△	○			Note	○
F	○	○	▼	○				▼
H	△	▼	○	△				▼
R	○	○	△			Note		○
S								
U	Note			Note				
T								○
V	○	▼	▼	○			○	○

Note) one of them selectable    ◻ : Not available

### Made to Order

("How to Order" and the applicable models are different from those shown on this page. Be sure to refer to "Made to Order".)

Symbol	Description	Page for details
—	—	—
X6	With differential pressure gauge (GD40-2-01)	P.64
X26	N.C., N.O. auto drain, drain piping type	P.65

### Option \*3

Symbol	Description
—	—
F	Rubber material: Fluororubber
H	For medium air pressure (1.6 MPa)
J	Drain guide 1/4 female threaded *4
R	IN-OUT reversal direction
U	With differential pressure switch (30 V) *5
T	With element service indicator
V	Degreasing wash, *6 white vaseline

- \*4 Drain piping and piping for a stop valve such as ball valve are required.
- \*5 Differential pressure gauge is included, (but not assembled).
- \*6 Only body/housing is degreasing washed.

### Auto drain \*3

Symbol	Description
—	Drain cock (Without auto-drain)
C	N.C. auto drain
D	N.O. auto drain

\*3 Refer to the table below for the combination between the draining specification and option. (Only one draining specification is selectable).

## Options

**Symbol F: Rubber material: Fluororubber**

Fluororubber is used for the parts such as O-ring and gasket.

**Symbol H: For medium air pressure (1.6 MPa)**

Can be used up to 1.6 MPa at maximum.

**Symbol J: Drain guide 1/4 female threaded**

Can be piped to the drain exhaust port.

1/4 female thread

**Symbol R: IN-OUT reversal direction**

Air flow in the separator is changed to right to left. (Air flow direction of the standard: Left to right.)

**Symbol U: With differential pressure switch (with indicator)**

Saturation of the separator can be observed visually or by an electrical signal. (Element life check)

**Symbol T: With element service indicator**

Pressure drop 0.1 MPa

Saturation of the separator can be observed visually. (Element life check)

Max. contact capacity: 10 W DC  
Rated contact voltage (max. operating current): 30 V DC (0.33 A)

Reed switch

**Symbol V: Degreasing wash, white vaseline**

Body/housing is degreasing washed. The lubrication grease for O-ring and gasket is changed to white vaseline.



## How to Order

### AFF37B/75B

**AFF** **37B** - [ ] **10** [ ] [ ] - [ ] - [ ]

#### Body size

Symbol	Applicable compressor output (guide)
<b>37B</b>	37 kW
<b>75B</b>	75 kW

#### Thread type

Symbol	Type
—	Rc
<b>F</b>	G
<b>N</b>	NPT

#### Port size

Symbol	Size	Applicable body size	
		<b>37B</b>	<b>75B</b>
<b>10</b>	1	●	—
<b>14</b>	1 1/2	●	●
<b>20</b>	2	—	●

#### Accessory

Symbol	Description
—	—
<b>B</b>	Bracket *1

\*1 Bracket is included, (but not assembled).

#### Made to Order

("How to Order" and the applicable models are different from those shown on this page. Be sure to refer to "Made to Order".)

Symbol	Description	Page for details
—	—	—
<b>X6</b>	With differential pressure gauge (GD40-2-01)	P.64
<b>X26</b>	N.C., N.O. auto drain, drain piping type	P.65
<b>X12</b>	White vaseline specifications	P.65

#### Option \*2

Symbol	Description
—	—
<b>J</b>	Drain guide 1/4 female threaded *4
<b>R</b>	IN-OUT reversal direction
<b>T</b>	With element service indicator

\*4 Drain piping and piping for a stop valve such as ball valve are required.

#### Auto drain \*2

Symbol	Description
—	Drain cock (Without auto drain) *3
<b>D</b>	N.O. auto drain

\*2 Refer to "Auto Drain Specifications/Option Combinations".

\*3 Body size 75B is equipped with a ball valve (Rc3/8 female threaded). Mount a piping adapter IDF-AP609 (page 58) to the ball valve if NPT3/8 female threaded is required.



Note) Refer to "How to Order Bowl Assembly" on page 59.

### Auto Drain Specifications/Option Combinations

○ : Available    □ : Not available

Auto drain specifications/Option			Auto drain specifications				Applicable model	
			<b>D</b>	<b>J</b>	<b>R</b>	<b>T</b>	<b>AFF37B</b>	<b>AFF75B</b>
Auto drain specifications	N.O. auto drain	<b>D</b>	□	□	○	○	○	○
	Drain guide 1/4	<b>J</b>	□	○	○	○	□	□
Option	IN-OUT reversal direction	<b>R</b>	○	○	□	○	○	○
	With element service indicator	<b>T</b>	○	○	○	□	○	○

# Series AFF

## Flow Characteristics/Select the model taking the max. flow capacity into consideration. (Element oil saturation)



Note) Compressed air over max. flow line in the table below may not meet the specifications of the product. It may cause damage to the element.

**AFF2C**

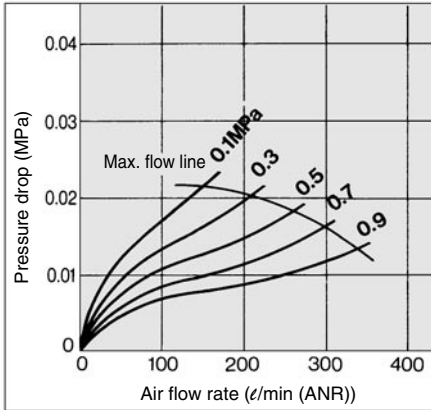

**AFF22C**

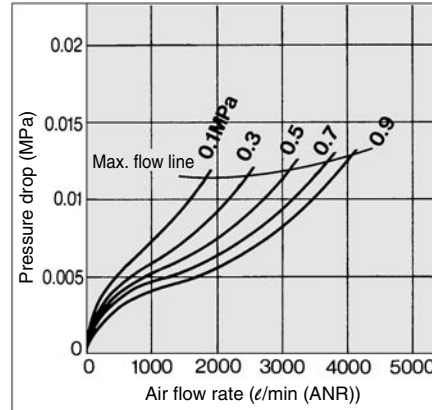

**AFF4C**

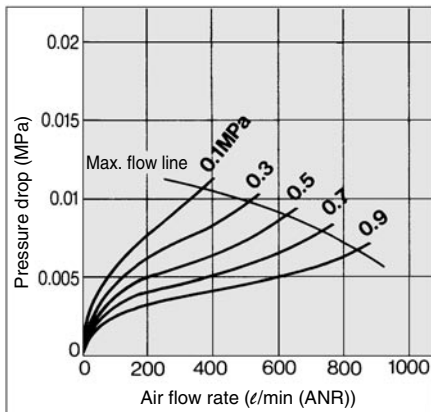

**AFF37B**

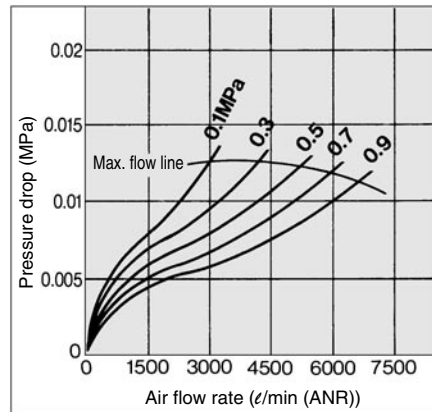

**AFF8C**

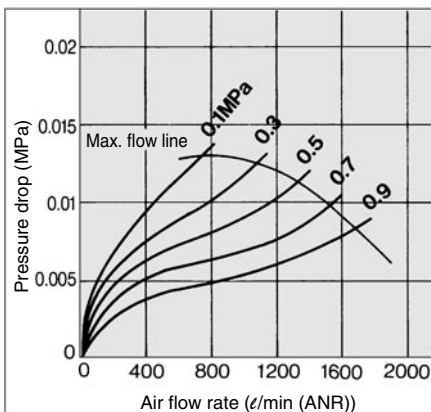

**AFF75B**

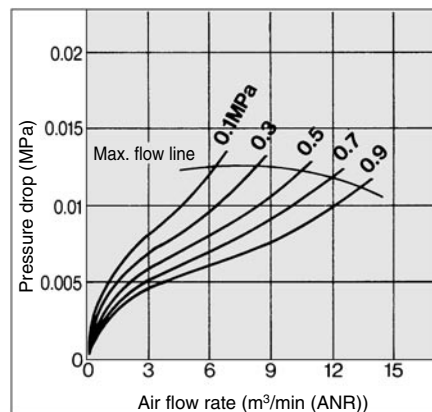

**AFF11C**

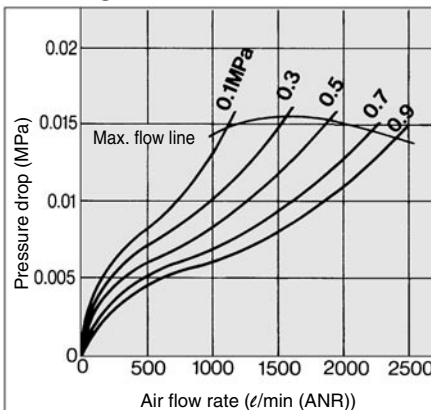



## Construction

### AFF2C to 22C, AFF37B

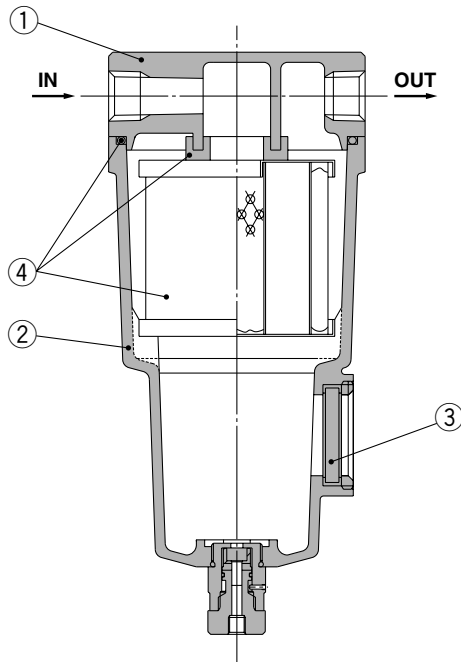

### AFF75B

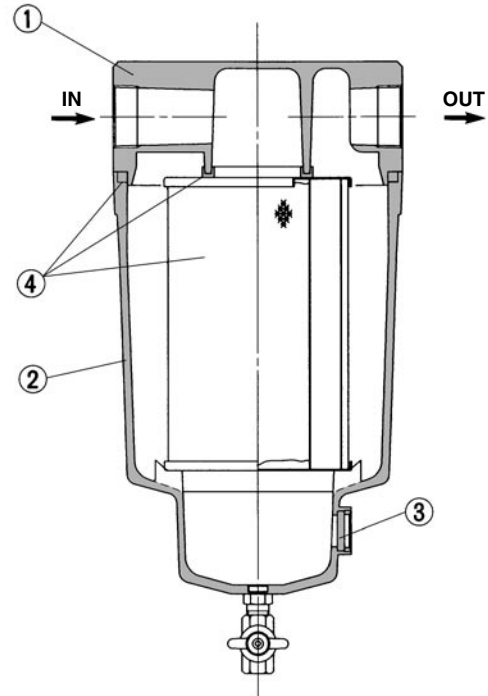

### Component Parts

No.	Description	Material	Note
1	<b>Body</b>	Aluminum die-casted	Chrome treated
2	<b>Housing</b>	Aluminum die-casted*	Epoxy coating on inner surface
3	<b>Sight glass</b>	Tempered glass	—

\* The AFF75B is aluminum casted.



Note) Refer to "How to Order Bowl Assembly" on page 59.



Note) Sight glass is indicated in the figure for easy understanding of component parts. However, it differs from the actual construction. Please refer to pages 15 through to 17 for details.

### Replacement Parts

No.	Description	Material	Applicable model	Model						
				AFF2C	AFF4C	AFF8C	AFF11C	AFF22C	AFF37B	AFF75B
4	<b>Element assembly</b>	Cotton paper, others	Except option F	AFF-EL2B	AFF-EL4B	AFF-EL8B	AFF-EL11B	AFF-EL22B	AFF-EL37B	AFF-EL75B
			For option F	AFF-EL2B-F	AFF-EL4B-F	AFF-EL8B-F	AFF-EL11B-F	AFF-EL22B-F	—	—

\* Element assembly: With gasket (1 pc.) and O-ring (1 pc.)

\* Refer to back page 6 for replacement of auto drain.

\* Element assemblies for Made to Order (X6, X12, X20, X26) are same as those for standard (see the above table).

# Series AFF

## Dimensions

AFF2C to 22C

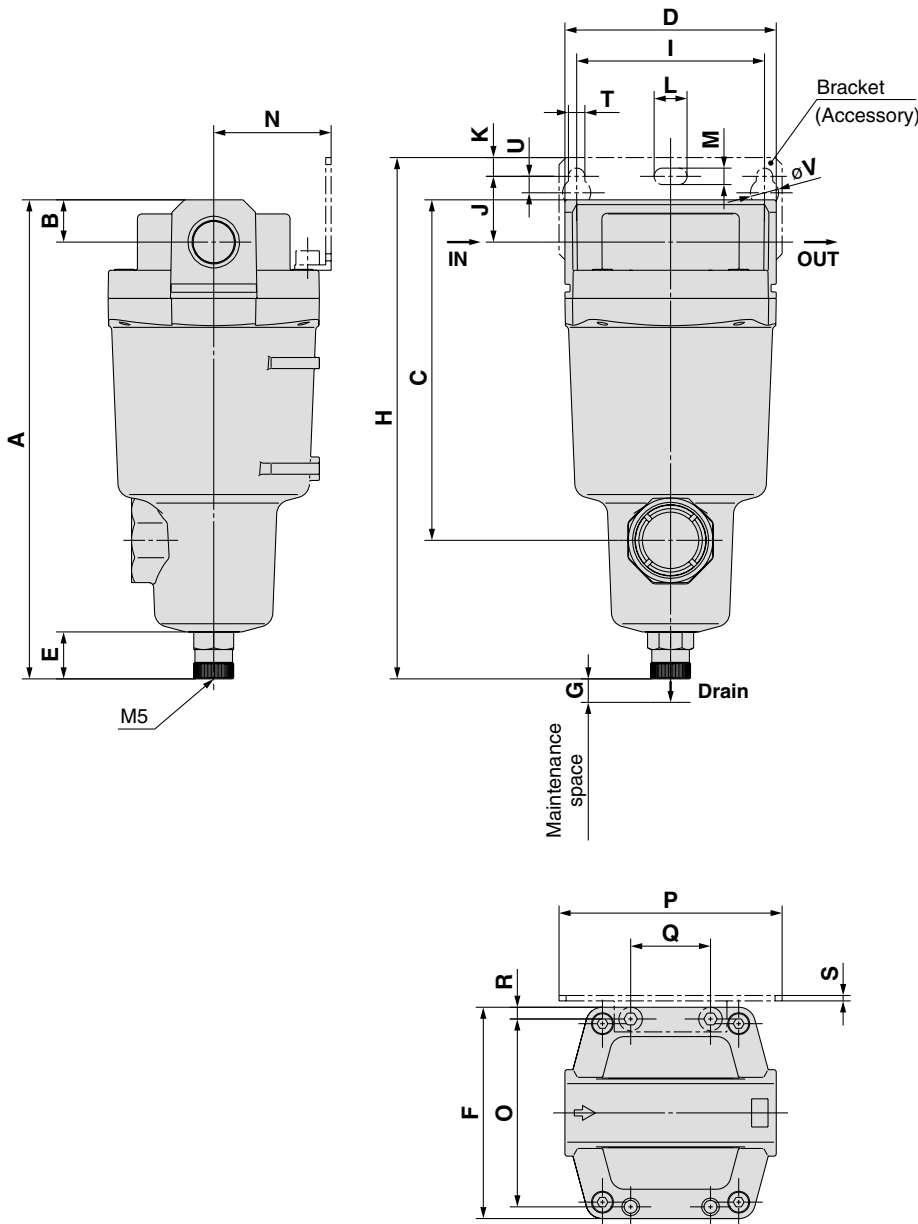

### Auto drain

C: With auto drain (N.C.)  
D: With auto drain (N.O.)

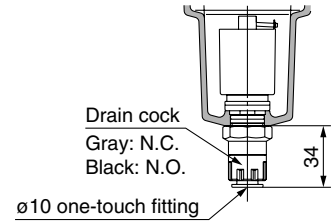

Combination of D: With auto drain (N.O.)  
and H: For medium air pressure

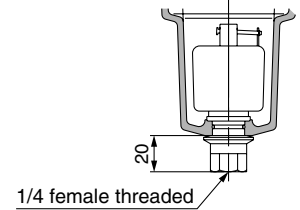

### Option

J: Drain guide 1/4 female threaded

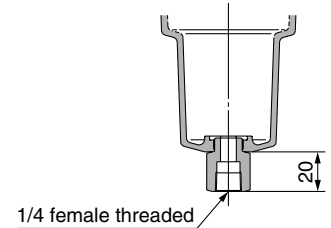

U: With differential pressure switch (with indicator)

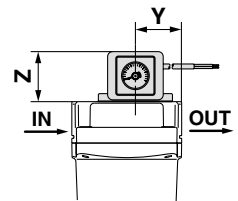

T: With element service indicator

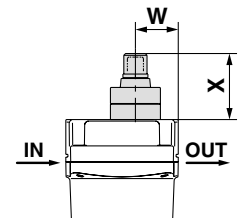

Model	Port size	A	B	C	D	E	F	G	Bracket related dimensions													Element service indicator related dimensions		Differential pressure switch related dimensions			
									H	I	J	K	T	U	L	M	V	N	O	P	Q	R	S	W	X	Y	Z
AFF2C	1/8, 1/4	158	10	99	63	20	63	10	173	56	20	5	6	6	12	6	10	35	54	70	26	4.5	1.6	24	37	32	41
AFF4C	1/4, 3/8	172	14	113	76	20	76	10	190	66	24	8	6	6	12	6	10	40	66	80	28	5	2	27	37	36	41
AFF8C	3/8, 1/2	204	18	145	90	20	90	10	222	80	28	8	7	7	14	7	12	50	80	95	34	5	2.3	32	37	42	41
AFF11C	1/2, 3/4	225	20	166	106	20	106	10	246	90	31	10	9	9	18	9	15	55	88	111	50	9	3.2	37	37	43	41
AFF22C	3/4, 1	259	24	200	122	20	122	15	278	100	33	10	9	9	18	9	15	65	102	126	60	10	3.2	39	37	51	41

**Dimensions**

**AFF37B**

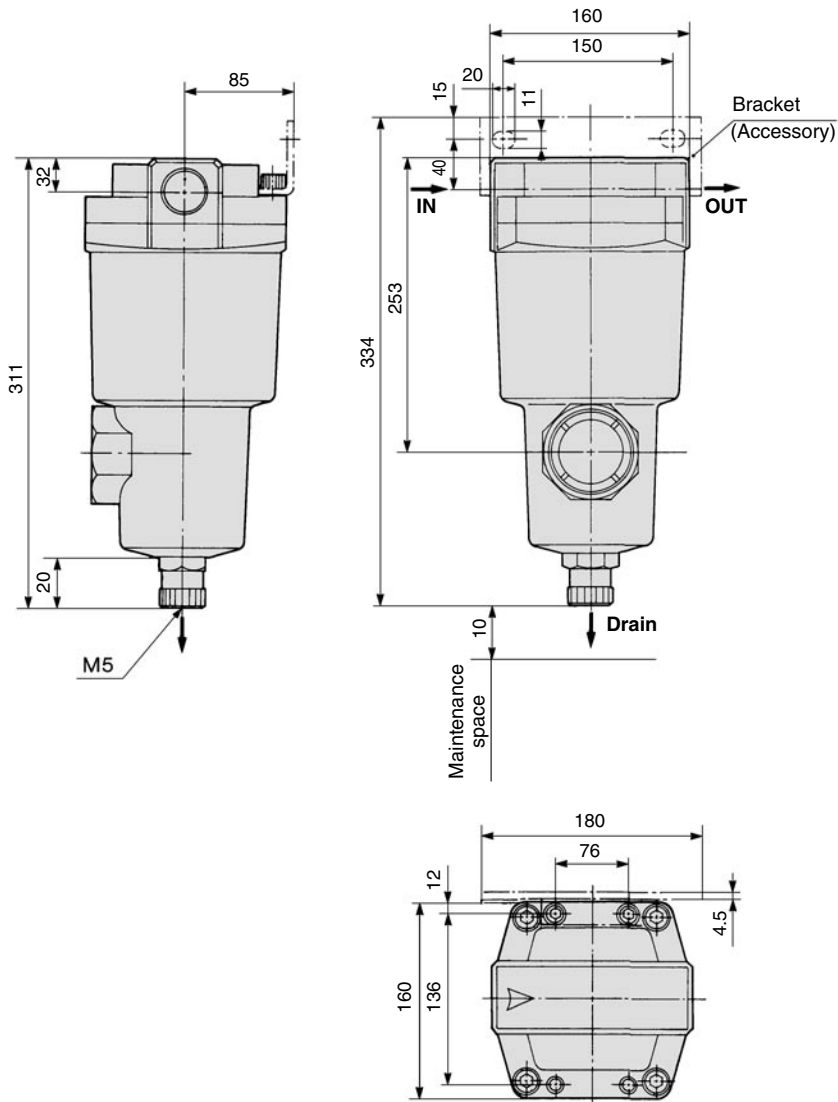

**Auto drain**

**D: With auto drain (N.O.)**

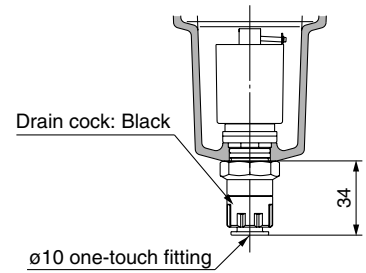

**Option**

**J: Drain guide 1/4 female threaded**

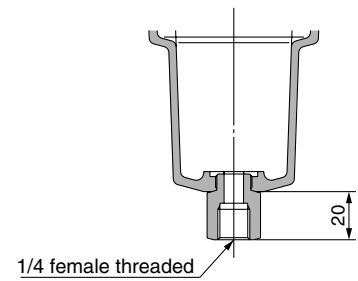

**T: With element service indicator**

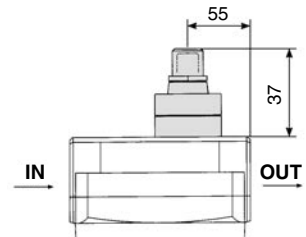

# Series AFF

## Dimensions

### AFF75B

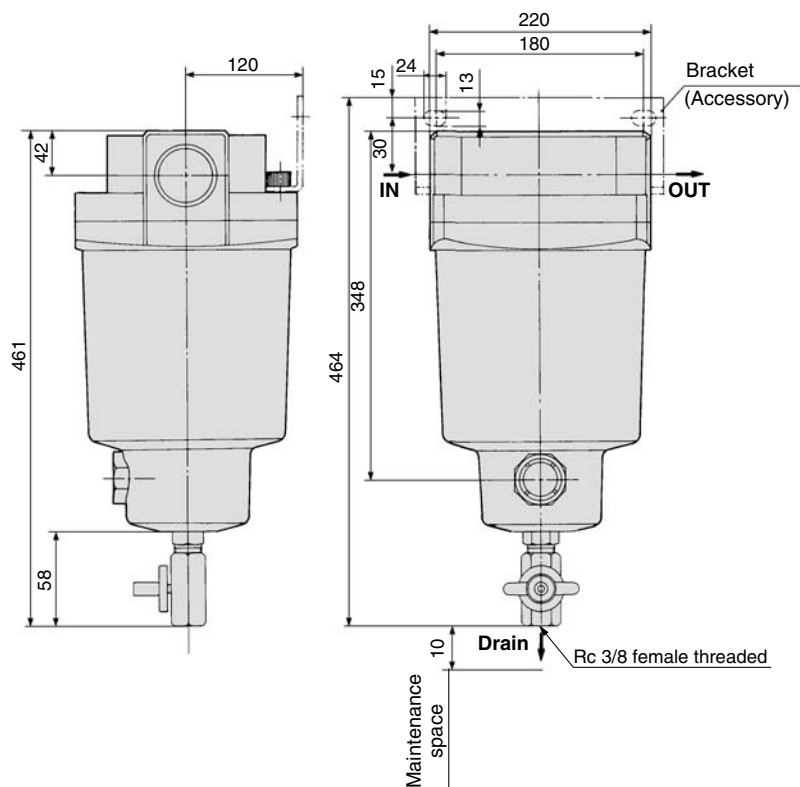

### Auto drain

D: With auto drain (N.O.)  
for AFF75B

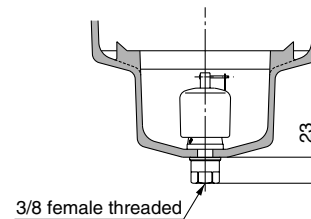

### Option

T: With element service indicator

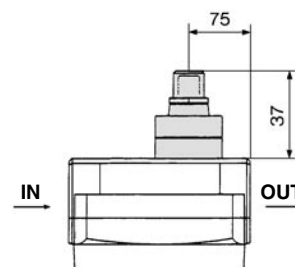

# Mist Separator

# Series AM

**Can remove oil mist in compressed air and remove particles such as rust or carbon of more than 0.3 μm.**

**Modular connection is possible with AM150C to 550C.**  
(For details, refer to page 58.)



AM150C to 550C

AM650/850

Symbol

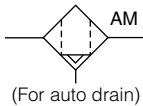
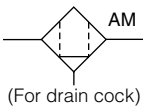

**Made to Order**  
(For details, refer to page 63.)

## Model

Model	AM150C	AM250C	AM350C	AM450C	AM550C	AM650	AM850
Rated flow (ℓ/min (ANR)) <sup>Note)</sup>	300	750	1500	2200	3700	6000	12000
Port size	1/8, 1/4	1/4, 3/8	3/8, 1/2	1/2, 3/4	3/4, 1	1, 1 1/2	1 1/2, 2
Mass (kg)	0.38	0.55	0.9	1.4	2.1	4.2	10.5



Note) Max. flow at 0.7 MPa.

Max. flow varies depending on the operating pressure.

Refer to "Flow Characteristics" (page 21) and "Maximum Air Flow" (page 22).



Note) Refer to "Made to Order" (page 63) for high flow type of AM850 or more.

## Specifications

Fluid	Compressed air
Max. operating pressure	1.0 MPa
Min. operating pressure*	0.05 MPa
Proof pressure	1.5 MPa
Ambient and fluid temperature	5 to 60°C
Nominal filtration rating	0.3 μm (Filtration efficiency: 99.9%)
Oil mist density at outlet	Max. 1.0 mg/m <sup>3</sup> (ANR) (=0.8 ppm)*
Element life	2 years or when pressure drop reached 0.1 MPa

\* With auto drain: 0.1 MPa (N.O. type) or 0.15 MPa (N.C. type)

\* Oil mist density at 30 mg/m<sup>3</sup> (ANR) blown out by compressor.

## Accessory

Applicable model	AM150C	AM250C	AM350C	AM450C	AM550C	AM650	AM850
Bracket assembly (with 2 mounting screws)	AM-BM101	AM-BM102	AM-BM103	AM-BM104	AM-BM105	BM56	BM57

## Caution

**Be sure to read this before handling.**

**Refer to back pages 1 and 2 for Safety Instructions, "Precautions for Handling Pneumatic Devices" (M-03-E3A) for Common Precautions, and back pages 3 through to 7 for Specific Product Precautions.**

## How to Order



### AM150C to 550C

AM 550C - [ ] 10 [ ] [ ] - [ ] - [ ]

#### Body size

Symbol	Applicable compressor output (guide)
150C	2.2 kW
250C	3.7 kW
350C	7.5 kW
450C	11 kW
550C	22 kW

#### Thread type

Symbol	Type
—	Rc
F	G*1
N	NPT

\*1 Conforms to ISO1179-1.

#### Port size

Symbol	Size	Applicable body size				
		150C	250C	350C	450C	550C
01	1/8	●				
02	1/4	●	●			
03	3/8		●	●		
04	1/2			●	●	
06	3/4				●	●
10	1					●

#### Accessory

Symbol	Description
—	—
B	Bracket *2

\*2 Bracket is included, (but not assembled).

#### Made to Order

("How to Order" and the applicable models are different from those shown on this page. Be sure to refer to "Made to Order".)

Symbol	Description	Page for details
—	—	—
X6	With differential pressure gauge (GD40-2-01)	P.64
X26	N.C., N.O. auto drain, drain piping type	P.65

#### Option \*3

Symbol	Description
—	—
F	Rubber material: Fluororubber
H	For medium air pressure (1.6 MPa)
J	Drain guide 1/4 female threaded *4
R	IN-OUT reversal direction
U	With differential pressure switch (30 VDC) *5
T	Element service indicator
V	Degreasing wash, *6 white vaseline

\*4 Drain piping and piping for a stop valve such as ball valve are required.

\*5 Differential pressure gauge is included, (but not assembled).

\*6 Only body/housing is degreasing washed.

#### Auto Drain Specifications/Option Combinations

○ : All draining specifications are available (including drain guide, J type).  
 △ : N.C. auto drain (C type) is not available.  
 ▼ : N.C. auto drain (C type) and N.O. auto drain (D type) are not available.

	—	F	H	R	S	U	T	V
—	○	○	△	○		Note		○
F	○	○	▼	○				▼
H	△	▼	△	△				▼
R	○	○	△			Note		○
S								
U	Note			Note				
T								○
V	○	▼	▼	○			○	○

Note) one of them selectable    ◻ : Not available

#### Auto drain \*3

Symbol	Description
—	Drain cock (Without auto drain)
C	N.C. auto drain
D	N.O. auto drain

\*3 Refer to the table below for the combination between the draining specification and option. (Only one draining specification is selectable).

## Options

**Symbol F: Rubber material: Fluororubber**

Fluororubber is used for the parts such as O-ring and gasket.

**Symbol H: For medium air pressure (1.6 MPa)**

Can be used up to 1.6 MPa at maximum.

**Symbol J: Drain guide 1/4 female threaded**

Can be piped to the drain exhaust port.

1/4 female threaded

**Symbol R: IN-OUT reversal direction**

Air flow in the separator is changed to right to left. (Air flow direction of the standard: Left to right.)

**Symbol U: With differential pressure switch (with indicator)**

Saturation of the separator can be observed visually or by an electrical signal. (Element life check)

**Symbol T: With element service indicator**

Pressure drop 0.1 MPa

Saturation of the separator can be observed visually. (Element life check)

Max. contact capacity: 10 W DC  
 Rated contact voltage (max. operating current): 30 V DC (0.33 A)

Reed switch

**Symbol V: Degreasing wash, white vaseline**

Body/housing is degreasing washed. The lubrication grease for O-ring and gasket is changed to white vaseline.



## How to Order

### AM650/850

AM **650** - [ ] **10** [ ] [ ] - [ ] - [ ]

#### Body size

Symbol	Applicable compressor output (guide)
<b>650</b>	37 kW
<b>850</b>	75 kW

#### Thread type

Symbol	Type
—	Rc
<b>F</b>	G
<b>N</b>	NPT

#### Port size

Symbol	Size	Applicable body size	
		650	850
<b>10</b>	1	●	—
<b>14</b>	1 1/2	●	●
<b>20</b>	2	—	●

#### Accessory

Symbol	Description
—	—
<b>B</b>	Bracket *1

\*1 Bracket is included, (but not assembled).

#### Made to Order

("How to Order" and the applicable models are different from those shown on this page. Be sure to refer to "Made to Order".)

Symbol	Description	Page for details
—	—	—
<b>X6</b>	With differential pressure gauge (GD40-2-01)	P.64
<b>X26</b>	N.C., N.O. auto drain, drain piping type	P.65
<b>X12</b>	White vaseline specifications	P.65

#### Option \*2

Symbol	Description
—	—
<b>J</b>	Drain guide 1/4 female threaded *4
<b>R</b>	IN-OUT reversal direction
<b>T</b>	With element service indicator

\*4 Drain piping and piping for a stop valve such as ball valve are required.

#### Auto drain \*2

Symbol	Description
—	Drain cock (Without auto drain) *3
<b>D</b>	N.O. auto drain

\*2 Refer to "Auto Drain Specifications/Option Combinations".

\*3 Body size 850 is equipped with a ball valve (Rc3/8 female threaded). Mount a piping adapter IDF-AP609 (page 58) to the ball valve if NPT3/8 female threaded is required.



Note) Refer to "How to Order Bowl Assembly" on page 59.

### Auto Drain Specifications/Option Combinations

○ : Available    □ : Not available

Auto drain specifications/Option			Auto drain specifications		Option			Applicable model	
			<b>D</b>	<b>J</b>	<b>R</b>	<b>T</b>	<b>AM650</b>	<b>AM850</b>	
Auto drain specifications	N.O. auto drain	<b>D</b>	□	□	○	○	○	○	
	Drain guide 1/4	<b>J</b>	□	□	○	○	○	□	
Option	IN-OUT reversal direction	<b>R</b>	○	○	□	○	○	○	
	With element service indicator	<b>T</b>	○	○	○	□	○	○	

# Series AM

## Flow Characteristics (Element oil saturation)



Note) Compressed air over max. flow line in the table below may not meet the specifications of the product. It may cause damage to the element.

**AM150C**

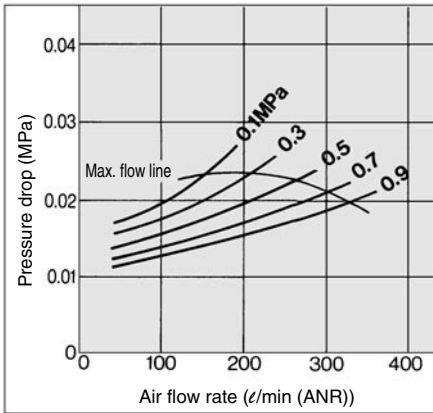

**AM450C**

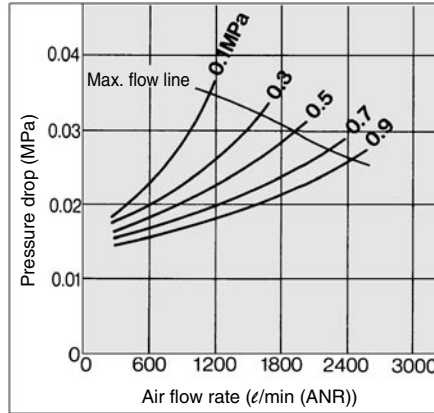

**AM850**

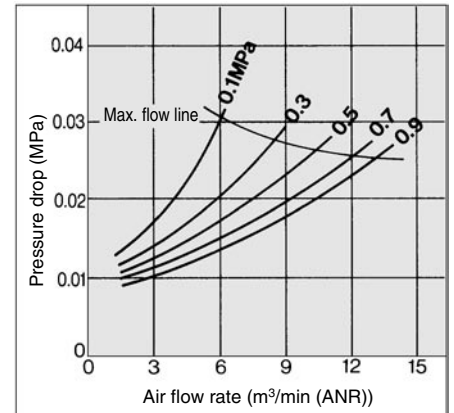

**AM250C**

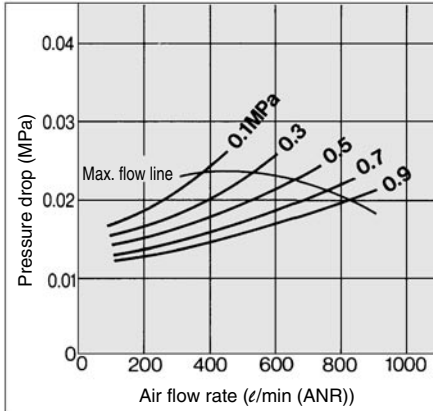

**AM550C**

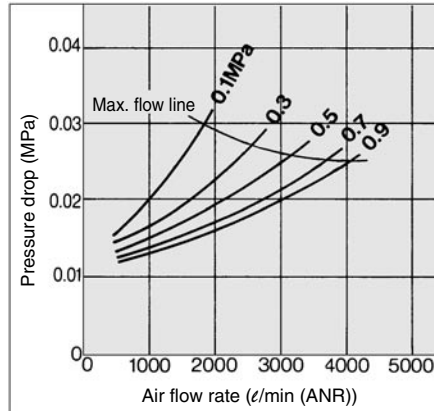

**AM350C**

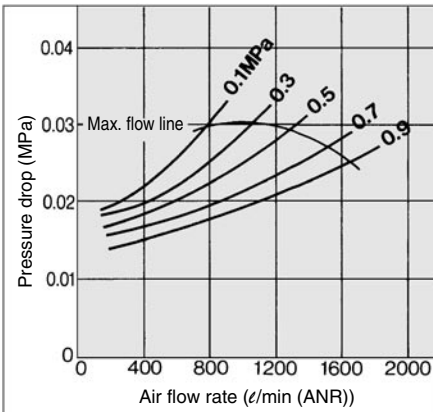

**AM650**

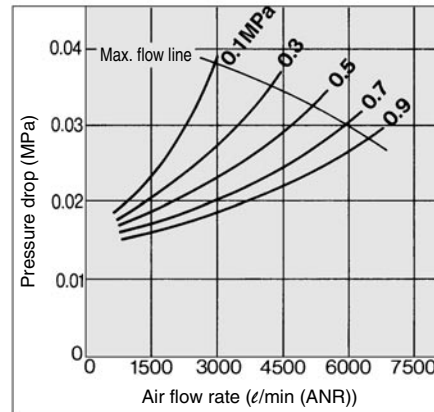



## Construction

### AM150C to 550C, AM650

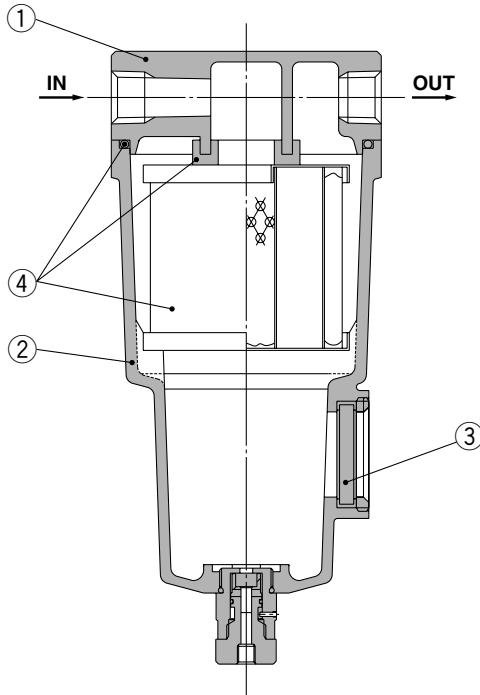

### AM850

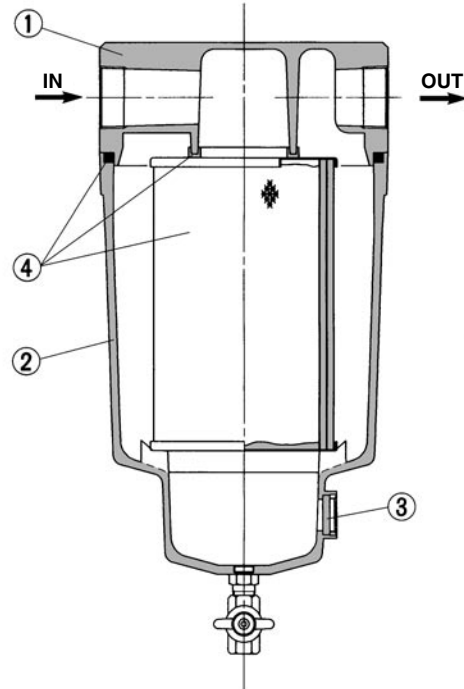

### Component Parts

No.	Description	Material	Note
1	<b>Body</b>	Aluminum die-casted	Chrome treated
2	<b>Housing</b>	Aluminum die-casted*	Epoxy coating on inner surface
3	<b>Sight glass</b>	Tempered glass	—

\* The AM850 is aluminum casted.



Note) Refer to "How to Order Bowl Assembly" on page 59.



Note) Sight glass is indicated in the figure for easy understanding of component parts. However, it differs from the actual construction. Refer to dimensions on pages 23 through to 25 for details.

### Replacement Parts

No.	Description	Material	Applicable model	Model						
				AM150C	AM250C	AM350C	AM450C	AM550C	AM650	AM850
4	<b>Element assembly</b>	Glass fiber, others	Except option F	AM-EL150	AM-EL250	AM-EL350	AM-EL450	AM-EL550	AM-EL650	AM-EL850
			For option F	AM-EL150-F	AM-EL250-F	AM-EL350-F	AM-EL450-F	AM-EL550-F	—	—

\* Element assembly: With gasket (1 pc.) and O-ring (1 pc.)

\* Refer to back page 6 for replacement of auto drain.

\* Element assemblies for Made to Order (X6, X12, X20, X26) are same as those for standard (see the above table).

### Maximum Air Flow

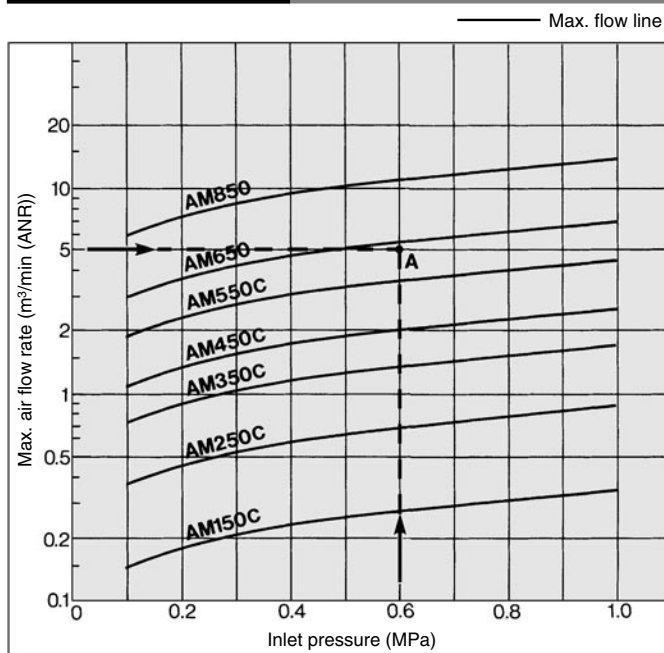

### Model Selection

Select a model in accordance with the following procedure taking the inlet pressure and the max. air flow rate into consideration.

(Example) Inlet pressure: 0.6 MPa

Max. air flow rate: 5 m<sup>3</sup>/min (ANR)

1. Obtain the intersecting point A of inlet pressure and max. air flow rate in the graph.
2. The AM650 is obtained when the max. flow line is above the intersecting point A in the graph.



Note) Make sure to select a model that has the max. flow line above the obtained intersecting point. With a model that has the max. flow line below the obtained intersecting point, the flow rate will be exceeded, thus leading to a problem such as being unable to satisfy the specifications.

# Series AM

## Dimensions

### AM150C to 550C

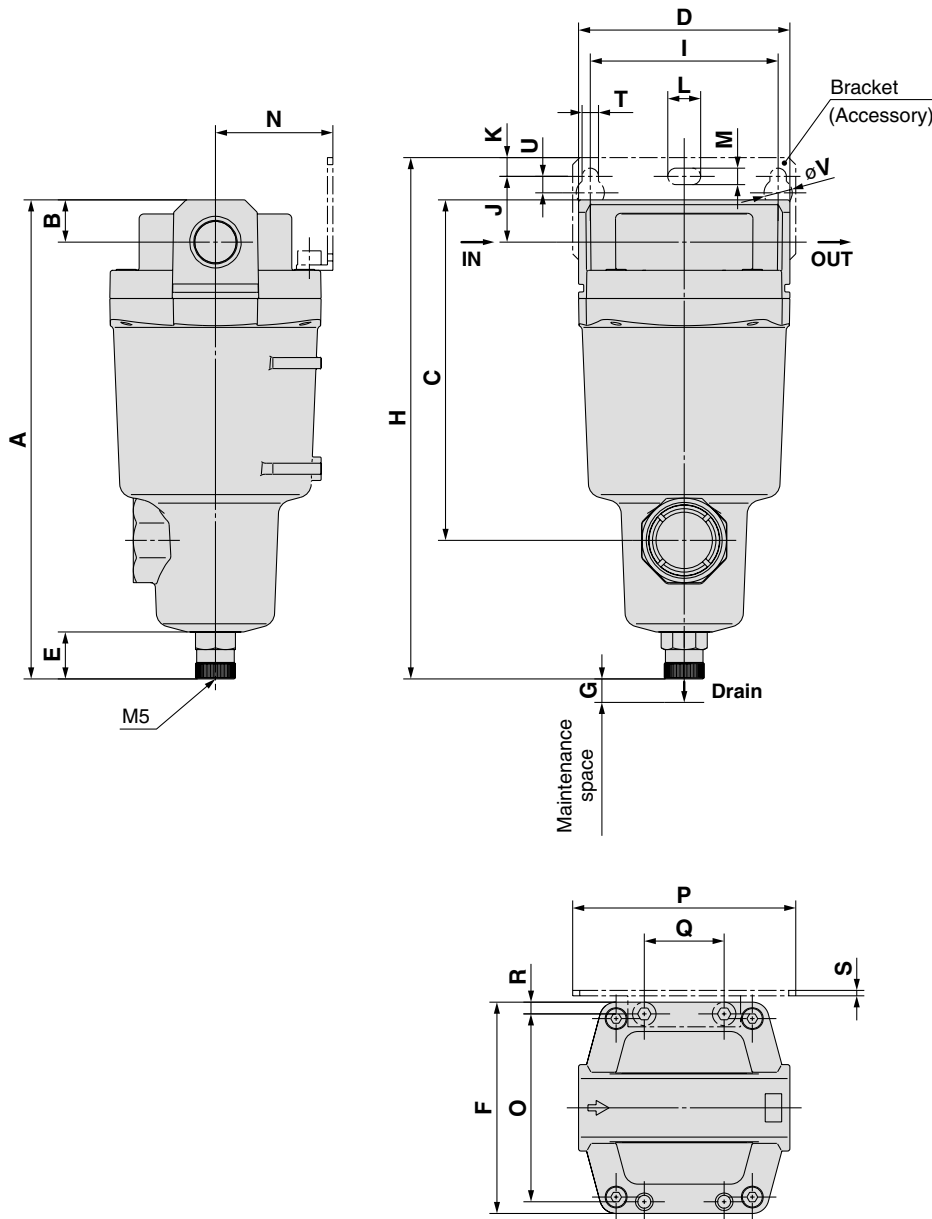

### Auto drain

C: With auto drain (N.C.)  
D: With auto drain (N.O.)

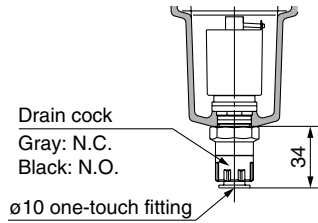

Combination of D: With auto drain (N.O.)  
and H: For medium air pressure

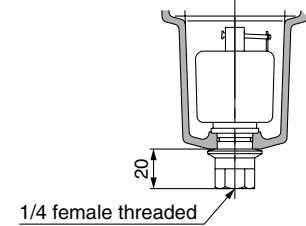

### Option

J: Drain guide 1/4 female threaded

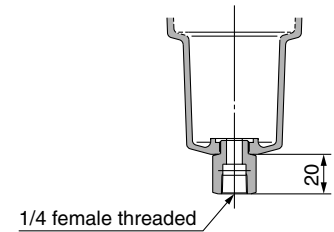

U: With differential pressure switch (with indicator)

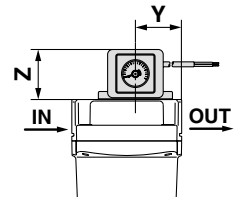

T: With element service indicator

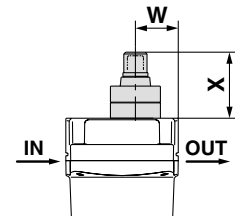

Model	Port size	A	B	C	D	E	F	G	Bracket related dimensions													Element service indicator related dimensions		Differential pressure switch related dimensions			
									H	I	J	K	T	U	L	M	V	N	O	P	Q	R	S	W	X	Y	Z
AM150C	1/8, 1/4	158	10	99	63	20	63	10	173	56	20	5	6	6	12	6	10	35	54	70	26	4.5	1.6	24	37	32	41
AM250C	1/4, 3/8	172	14	113	76	20	76	10	190	66	24	8	6	6	12	6	10	40	66	80	28	5	2	27	37	36	41
AM350C	3/8, 1/2	204	18	145	90	20	90	10	222	80	28	8	7	7	14	7	12	50	80	95	34	5	2.3	32	37	42	41
AM450C	1/2, 3/4	225	20	166	106	20	106	10	246	90	31	10	9	9	18	9	15	55	88	111	50	9	3.2	37	37	43	41
AM550C	3/4, 1	259	24	200	122	20	122	15	278	100	33	10	9	9	18	9	15	65	102	126	60	10	3.2	39	37	51	41

(mm)

**Dimensions**

**AM650**

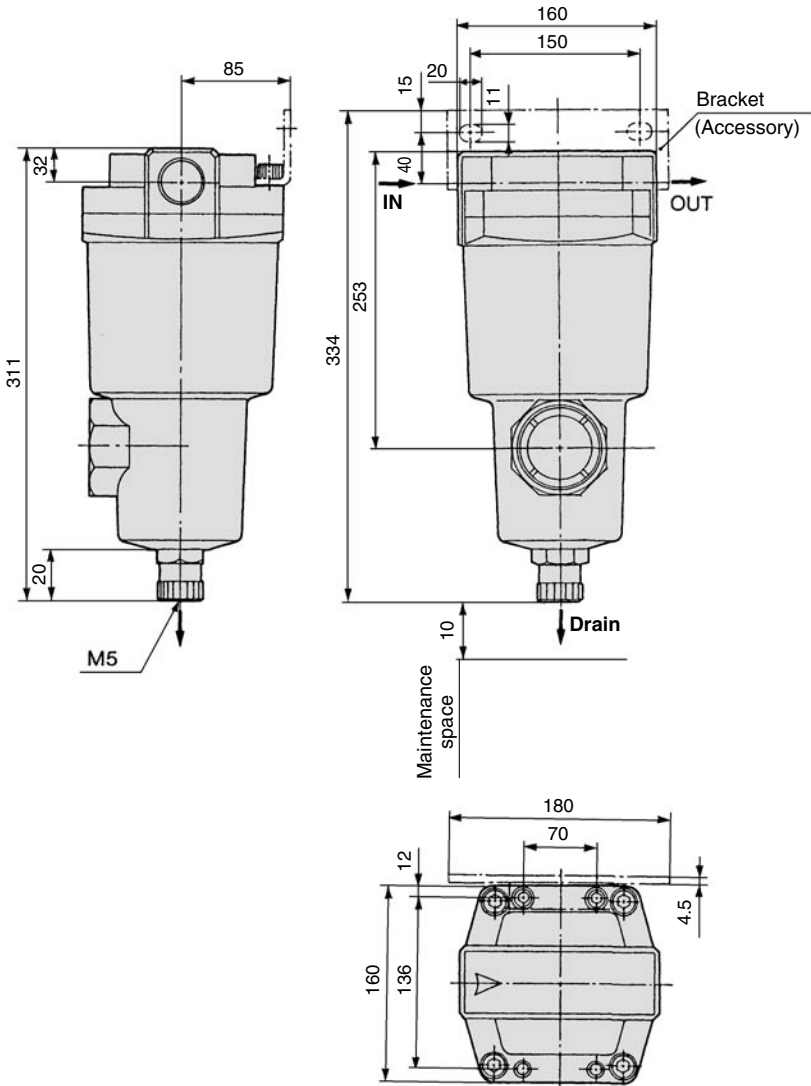

**Auto drain**

**D: With auto drain (N.O.)**

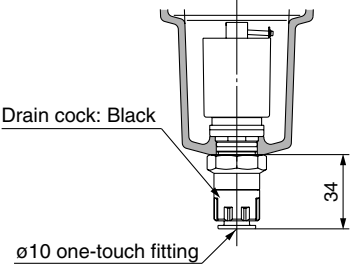

**Option**

**J: Drain guide 1/4 female threaded**

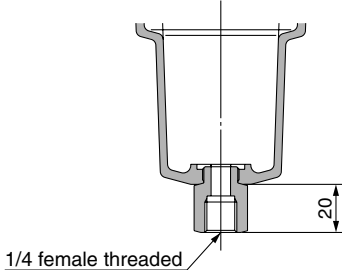

**T: With element service indicator**

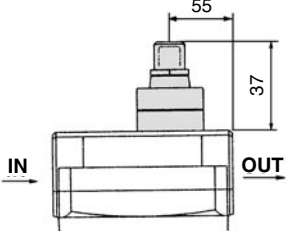

# Series AM

## Dimensions

### AM850

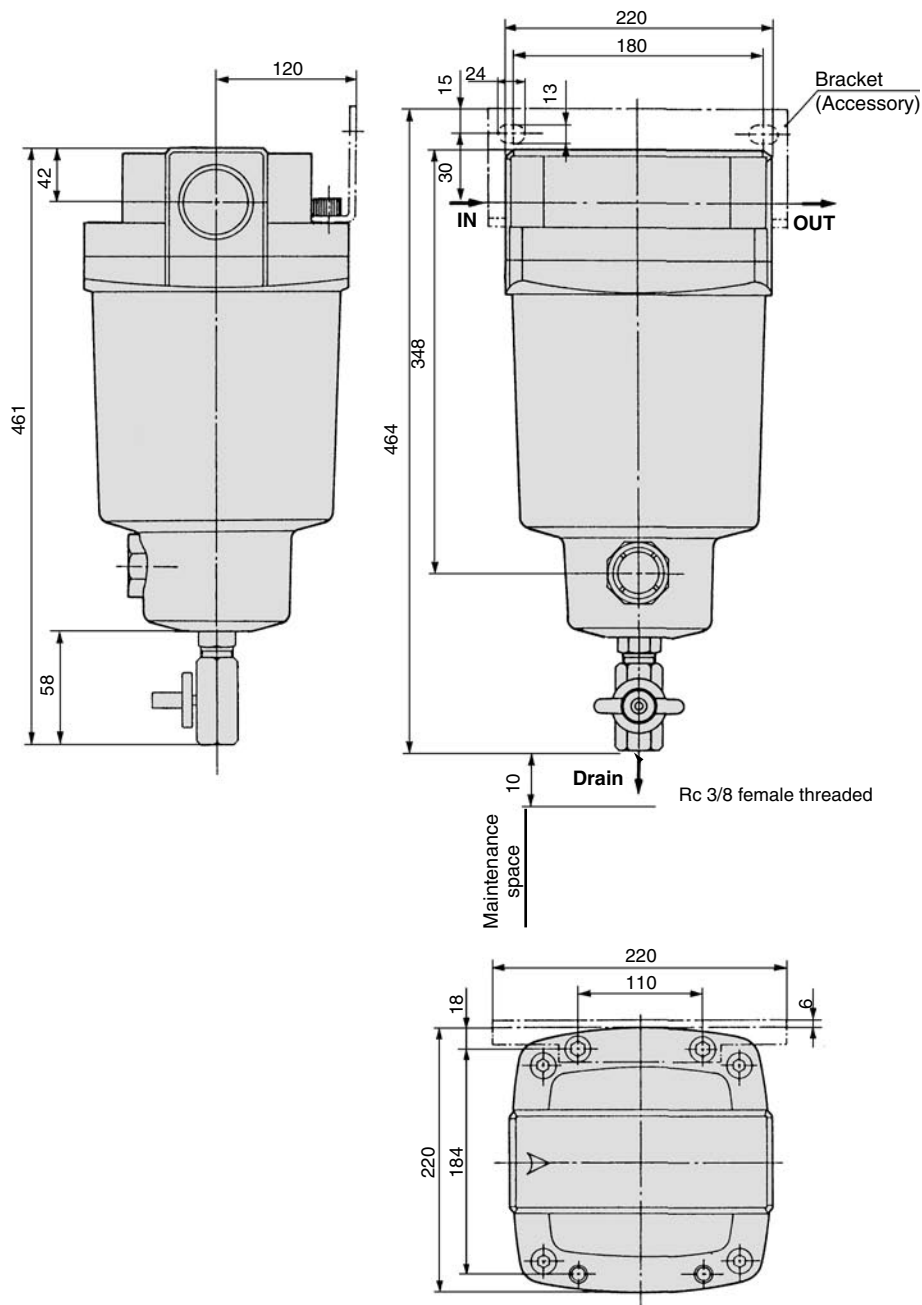

### Auto drain

D: With auto drain (N.O.)  
for AM850

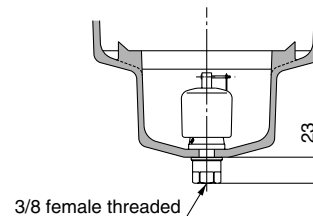

### Option

T: With element service indicator

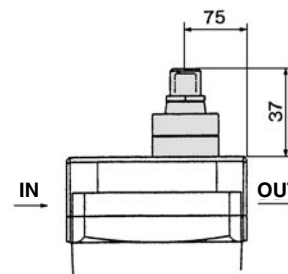

# Micro Mist Separator Series AMD

Can separate and remove aerosol state oil mist in compressed air and remove particles such as carbon or dust of more than 0.01  $\mu\text{m}$ .  
Use this product as a pre-filter for compressed air for precision instruments or clean room requiring higher clean air.

Modular connection is possible with AMD150C to 550C.  
(For details, refer to page 58.)



AMD150C to 550C

AMD650/850

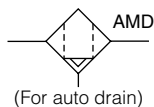
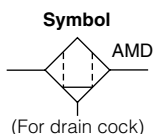

**Made to Order**  
(For details, refer to page 63.)

## Model

Model	AMD150C	AMD250C	AMD350C	AMD450C	AMD550C	AMD650	AMD850
Rated flow (Note) ( $\ell/\text{min}$ (ANR))	200	500	1000	2000	3700	6000	12000
Port size	1/8, 1/4	1/4, 3/8	3/8, 1/2	1/2, 3/4	3/4, 1	1, 1 1/2	1 1/2, 2
Mass (kg)	0.38	0.55	0.9	1.4	2.1	4.2	10.5



Note) Max. flow at 0.7 MPa.

Max. flow varies depending on the operating pressure.

Refer to "Flow Characteristics" (page 29) and "Maximum Air Flow" (page 28).

## Specifications

Fluid	Compressed air
Max. operating pressure	1.0 MPa
Min. operating pressure*	0.05 MPa
Proof pressure	1.5 MPa
Ambient and fluid temperature	5 to 60°C
Nominal filtration rating	0.01 $\mu\text{m}$ (Filtration efficiency: 99.9%)
Oil mist density at outlet	Max. 0.1 $\text{mg}/\text{m}^3$ (ANR)* (Before saturated with oil, less than 0.01 $\text{mg}/\text{m}^3$ (ANR) $\approx$ 0.008 ppm)
Element life	2 years (1 year for flange type) or when pressure drop reached 0.1 MPa

\* With auto drain: 0.1 MPa (N.O. type) or 0.15 MPa (N.C. type)

\* Oil mist density at 30  $\text{mg}/\text{m}^3$  (ANR) blown out by compressor.

## Accessory

Applicable model	AMD150C	AMD250C	AMD350C	AMD450C	AMD550C	AMD650	AMD850
Bracket assembly (with 2 mounting screws)	AM-BM101	AM-BM102	AM-BM103	AM-BM104	AM-BM105	BM56	BM57

## ⚠ Caution

Be sure to read this before handling.

Refer to back pages 1 and 2 for Safety Instructions, "Precautions for Handling Pneumatic Devices" (M-03-E3A) for Common Precautions, and back pages 3 through to 7 for Specific Product Precautions.

## How to Order



### AMD150C to 550C

AMD **550C** - [ ] **10** [ ] [ ] - [ ] - [ ]

**Body size**

150C
250C
350C
450C
550C

**Thread type**

Symbol	Type
—	Rc
F	G*1
N	NPT

\*1 Conforms to ISO1179-1.

**Port size**

Symbol	Size	Applicable body size				
		150C	250C	350C	450C	550C
01	1/8	●				
02	1/4	●	●			
03	3/8		●	●		
04	1/2			●	●	
06	3/4				●	●
10	1					●

**Accessory**

Symbol	Description
—	—
B	Bracket *2

\*2 Bracket is included, (but not assembled).

### Auto Drain Specifications/Option Combinations

- : All draining specifications are available (including drain guide, J type).
- △: N.C. auto drain (C type) is not available.
- ▼: N.C. auto drain (C type) and N.O. auto drain (D type) are not available.

	—	F	H	R	S	U	T	V
—	○	○	△	○			Note	○
F	○	○	▼	○				○
H	△	▼	△					▼
R	○	○	△			Note		○
S								
U	Note			Note				
T								○
V	○	▼	▼	○			○	○

Note) one of them selectable    ◻: Not available

### Made to Order

("How to Order" and the applicable models are different from those shown on this page. Be sure to refer to "Made to Order".)

Symbol	Description	Page for details
—	—	—
X6	With differential pressure gauge (GD40-2-01)	P.64
X26	N.C., N.O. auto drain, drain piping type	P.65

### Option \*3

Symbol	Description
—	—
F	Rubber material: Fluororubber
H	For medium air pressure (1.6 MPa)
J	Drain guide 1/4 female thread *4
R	IN-OUT reversal direction
U	With differential pressure switch (30 VDC) *5
T	With element service indicator
V	Degreasing wash, *6 white vaseline

\*4 Drain piping and piping for a stop valve such as ball valve are required.

\*5 Differential pressure gauge is included, (but not assembled).

\*6 Only body/housing is degreasing washed.

### Auto drain \*3

Symbol	Description
—	Drain cock (Without auto drain)
C	N.C. auto drain
D	N.O. auto drain

\*3 Refer to the table below for the combination between the draining specification and option. (Only one draining specification is selectable).

## Options

**Symbol F: Rubber material: Fluororubber**

Fluororubber is used for the parts such as O-ring and gasket.

**Symbol H: For medium air pressure (1.6 MPa)**

Can be used up to 1.6 MPa at maximum.

**Symbol J: Drain guide 1/4 female threaded**

Can be piped to the drain exhaust port.

1/4 female threaded

**Symbol R: IN-OUT reversal direction**

Air flow in the separator is changed to right to left. (Air flow direction of the standard: Left to right.)

**Symbol U: With differential pressure switch (with indicator)**

Saturation of the separator can be observed visually or by an electrical signal. (Element life check)

**Symbol T: With element service indicator**

Saturation of the separator can be observed visually. (Element life check)

Max. contact capacity: 10 W DC  
Rated contact voltage (max. operating current): 30 V DC (0.33 A)

Reed switch

**Symbol V: Degreasing wash, white vaseline**

Body/housing is degreasing washed. The lubrication grease for O-ring and gasket is changed to white vaseline.



## How to Order

### AMD650/850



#### Body size

650
850

#### Thread type

Symbol	Type
—	Rc
F	G
N	NPT

#### Port size

Symbol	Size	Applicable body size
10	1	650
14	1 1/2	650, 850
20	2	850

#### Accessory

Symbol	Description
—	—
B	Bracket *1

\*1 Bracket is included, (but not assembled).

#### Auto drain \*2

Symbol	Description
—	Drain cock (Without auto drain) *3
D	N.O. auto drain

\*2 Refer to "Auto Drain Specifications/Option Combinations".

\*3 Body size 850 is equipped with a ball valve (Rc3/8 female threaded). Mount a piping adapter IDF-AP609 (page 58) to the ball valve if NPT3/8 female threaded is required.

#### Option \*2

Symbol	Description
—	—
J	Drain guide 1/4 female threaded*4
R	IN-OUT reversal direction
T	With element service indicator

\*4 Drain piping and piping for a stop valve such as ball valve are required.

#### Made to Order

("How to Order" and the applicable models are different from those shown on this page. Be sure to refer to "Made to Order".)

Symbol	Description	Page for details
—	—	—
X6	With differential pressure gauge (GD40-2-01)	P.64
X26	N.C., N.O. auto drain, drain piping type	P.65
X12	White vaseline specifications	P.65

### Auto Drain Specifications/Option Combinations



Note) Refer to "How to Order Bowl Assembly" on page 59.

⊙: Available    □: Not available

Auto drain specifications/Option		Auto drain specifications				Option		Applicable model	
		D	J	R	T	AMD650	AMD850		
Auto drain specifications	N.O. auto drain	D	□	□	□	□	□	□	
Option	Drain guide 1/4	J	⊙	⊙	⊙	⊙	⊙	⊙	
	IN-OUT reversal direction	R	⊙	⊙	⊙	⊙	⊙	⊙	
	With element service indicator	T	⊙	⊙	⊙	⊙	⊙	⊙	

## Model Selection

Select a model in accordance with the following procedure taking the inlet pressure and the max. air flow rate into consideration.

(Example) Inlet pressure: 0.6 MPa

Max. air flow rate: 5 m<sup>3</sup>/min (ANR)

1. Obtain the intersecting point A of inlet pressure and max. air flow rate in the graph.
2. The AMD650 is obtained when the max. flow line is above the intersecting point A in the graph.



Note) Make sure to select a model that has the max. flow line above the obtained intersecting point. With a model that has the max. flow line below the obtained intersecting point, the flow rate will be exceeded, thus leading to a problem such as being unable to satisfy the specifications.

## Maximum Air Flow

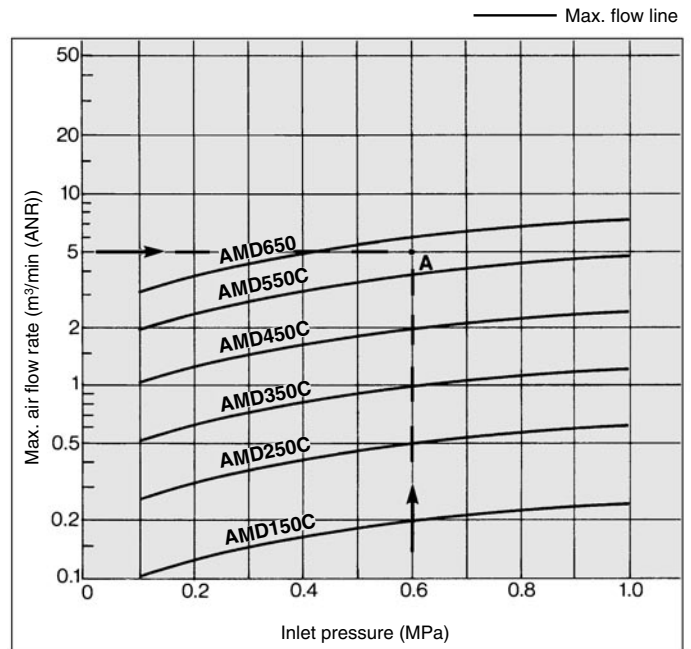

# Series AMD

**Flow Characteristics**/Select the model taking the max. flow capacity into consideration. (—— Element oil saturation - - - - Initial condition)



Note) Compressed air over max. flow line in the table below may not meet the specifications of the product. It may cause damage to the element.

**AMD150C**

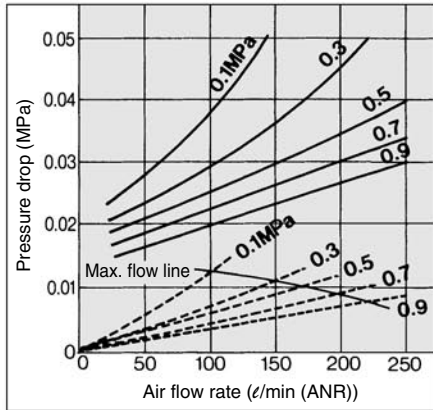

**AMD550C**

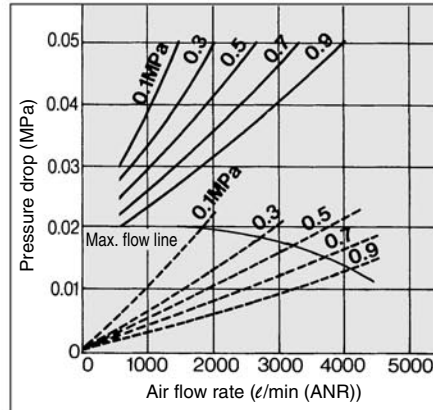

**AMD250C**

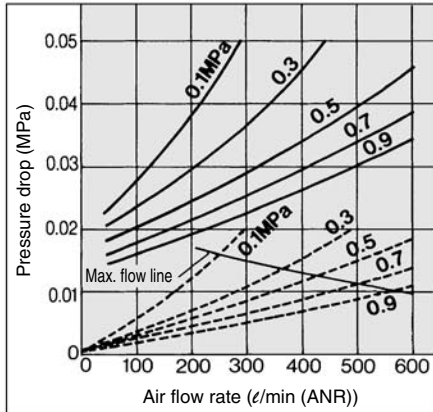

**AMD650**

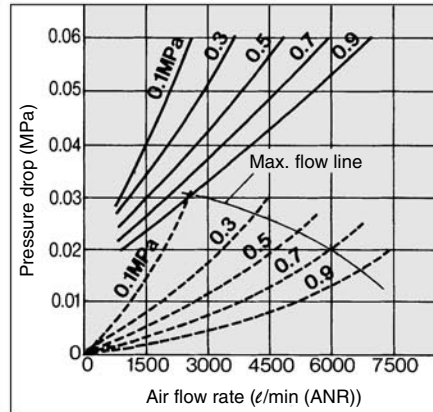

**AMD350C**

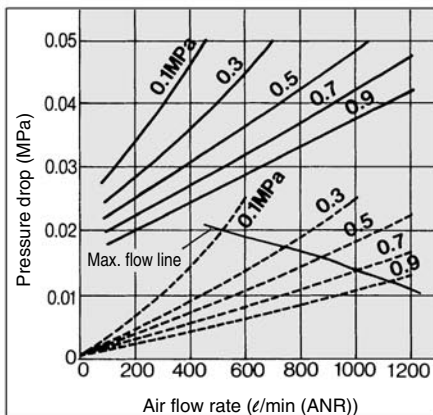

**AMD80□/81□**

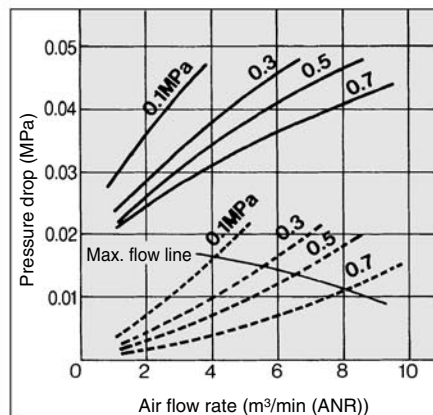

**AMD450C**

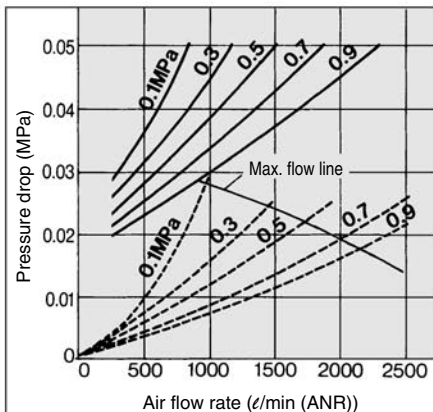

**AMD850**

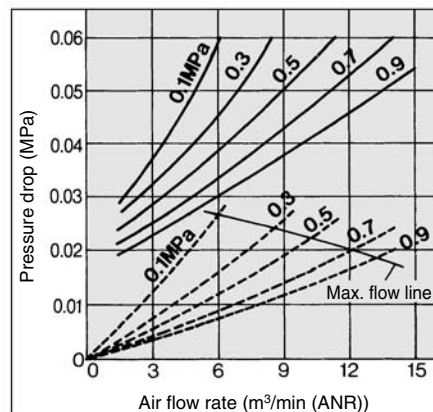



**Construction**

**AMD150C to 550C, AMD650**

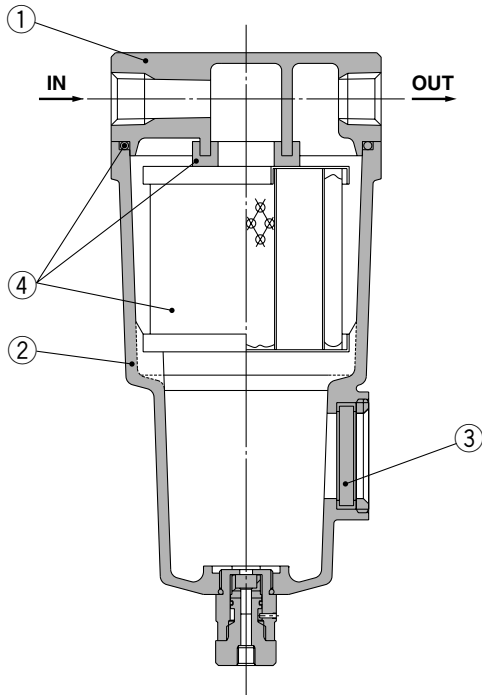

**AMD850**

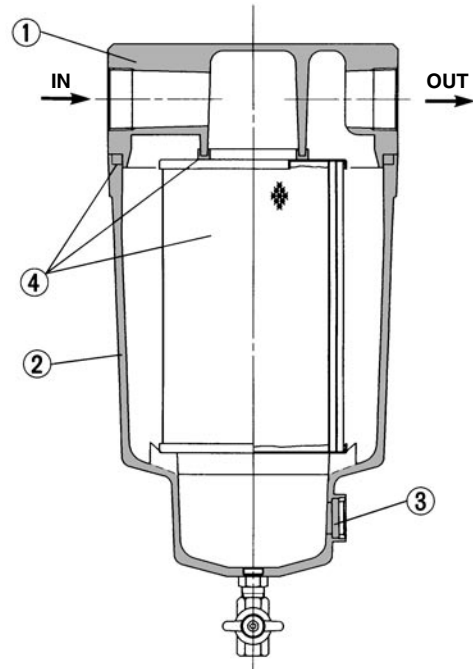

**Component Parts**

No.	Description	Material	Note
1	<b>Body</b>	Aluminum die-casted	Chrome treated
2	<b>Housing</b>	Aluminum die-casted*	Epoxy coating on inner surface
3	<b>Sight glass</b>	Tempered glass	—

\* The AMD850 is aluminum casted.



Note) Refer to "How to Order Bowl Assembly" on page 59.



Note) Sight glass is indicated in the figure for easy understanding of component parts. However, it differs from the actual construction. Refer to dimensions on pages 31 through to 33 for details.

**Replacement Parts**

No.	Description	Material	Applicable model	Model						
				AMD150C	AMD250C	AMD350C	AMD450C	AMD550C	AMD650	AMD850
4	<b>Element assembly</b>	Glass fiber, others	Except option F	AMD-EL150	AMD-EL250	AMD-EL350	AMD-EL450	AMD-EL550	AMD-EL650	AMD-EL850
			For option F	AMD-EL150-F	AMD-EL250-F	AMD-EL350-F	AMD-EL450-F	AMD-EL550-F	—	—

\* Element assembly: With gasket (1 pc.) and O-ring (1 pc.)

\* Refer to back page 6 for replacement of auto drain.

\* Element assemblies for Made to Order (X6, X12, X20, X26) are same as those for standard (see the above table).

# Series AMD

## Dimensions

### AMD150C to 550C

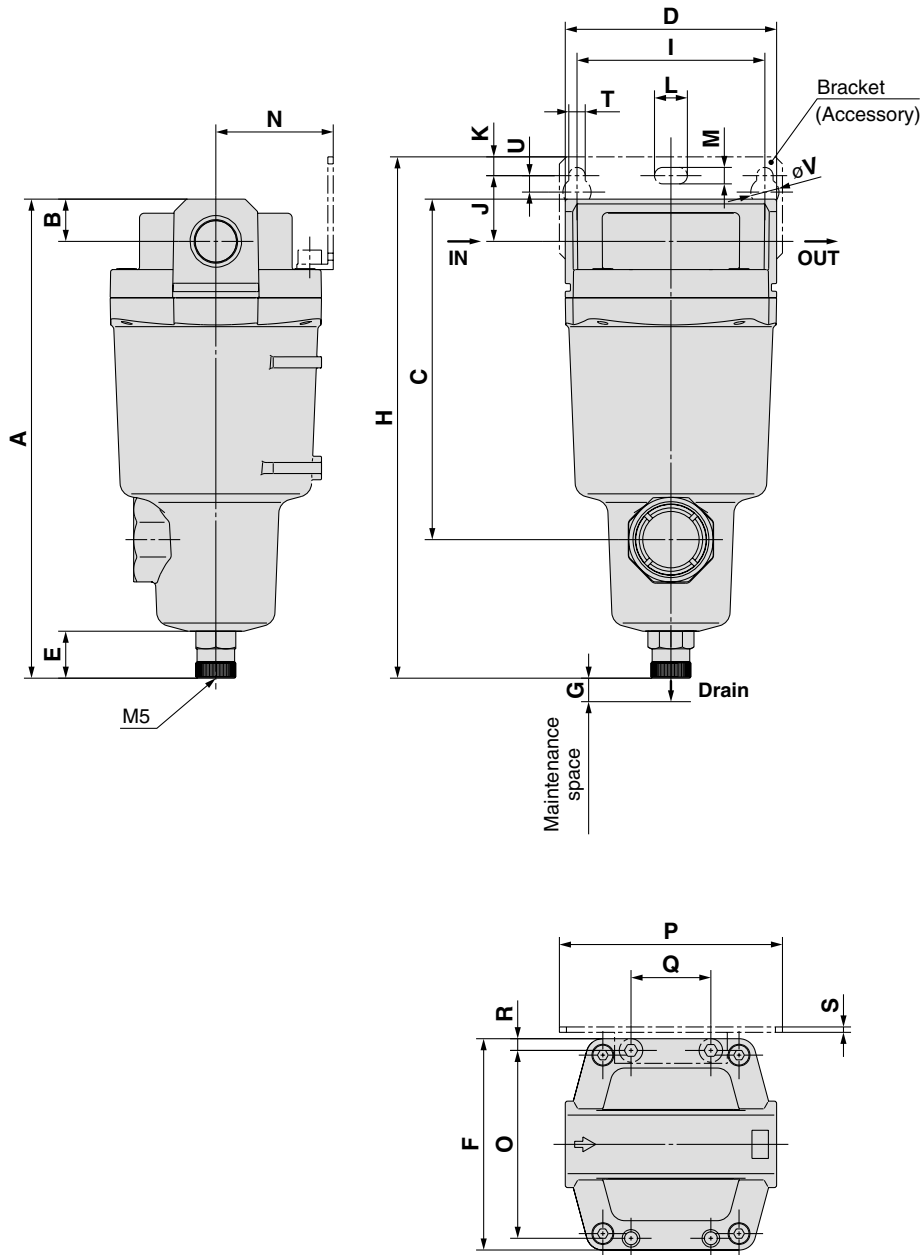

### Auto drain

**C:** With auto drain (N.C.)  
**D:** With auto drain (N.O.)

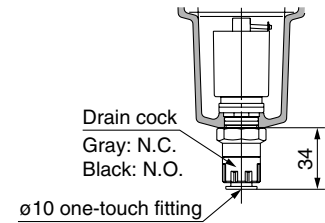

**Combination of D:** With auto drain (N.O.)  
**and H:** For medium air pressure

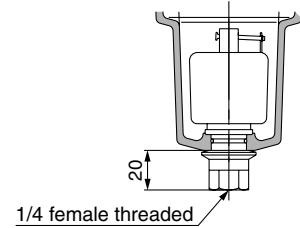

### Option

**J:** Drain guide 1/4 female threaded

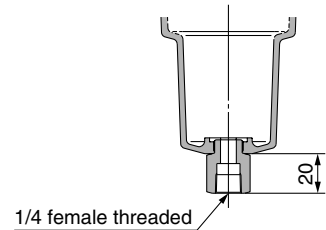

**U:** With differential pressure switch (with indicator)

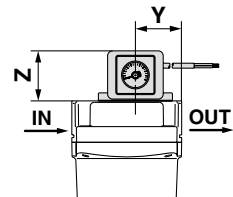

**T:** With element service indicator

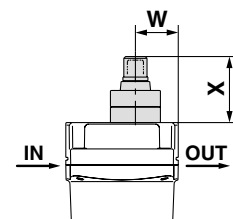

Model	Port size	A	B	C	D	E	F	G	Bracket related dimensions													Element service indicator related dimensions		Differential pressure switch related dimensions			
									H	I	J	K	T	U	L	M	V	N	O	P	Q	R	S	W	X	Y	Z
AMD150C	1/8, 1/4	158	10	99	63	20	63	10	173	56	20	5	6	6	12	6	10	35	54	70	26	4.5	1.6	24	37	32	41
AMD250C	1/4, 3/8	172	14	113	76	20	76	10	190	66	24	8	6	6	12	6	10	40	66	80	28	5	2	27	37	36	41
AMD350C	3/8, 1/2	204	18	145	90	20	90	10	222	80	28	8	7	7	14	7	12	50	80	95	34	5	2.3	32	37	42	41
AMD450C	1/2, 3/4	225	20	166	106	20	106	10	246	90	31	10	9	9	18	9	15	55	88	111	50	9	3.2	37	37	43	41
AMD550C	3/4, 1	259	24	200	122	20	122	15	278	100	33	10	9	9	18	9	15	65	102	126	60	10	3.2	39	37	51	41

(mm)

**Dimensions**

**AMD650**

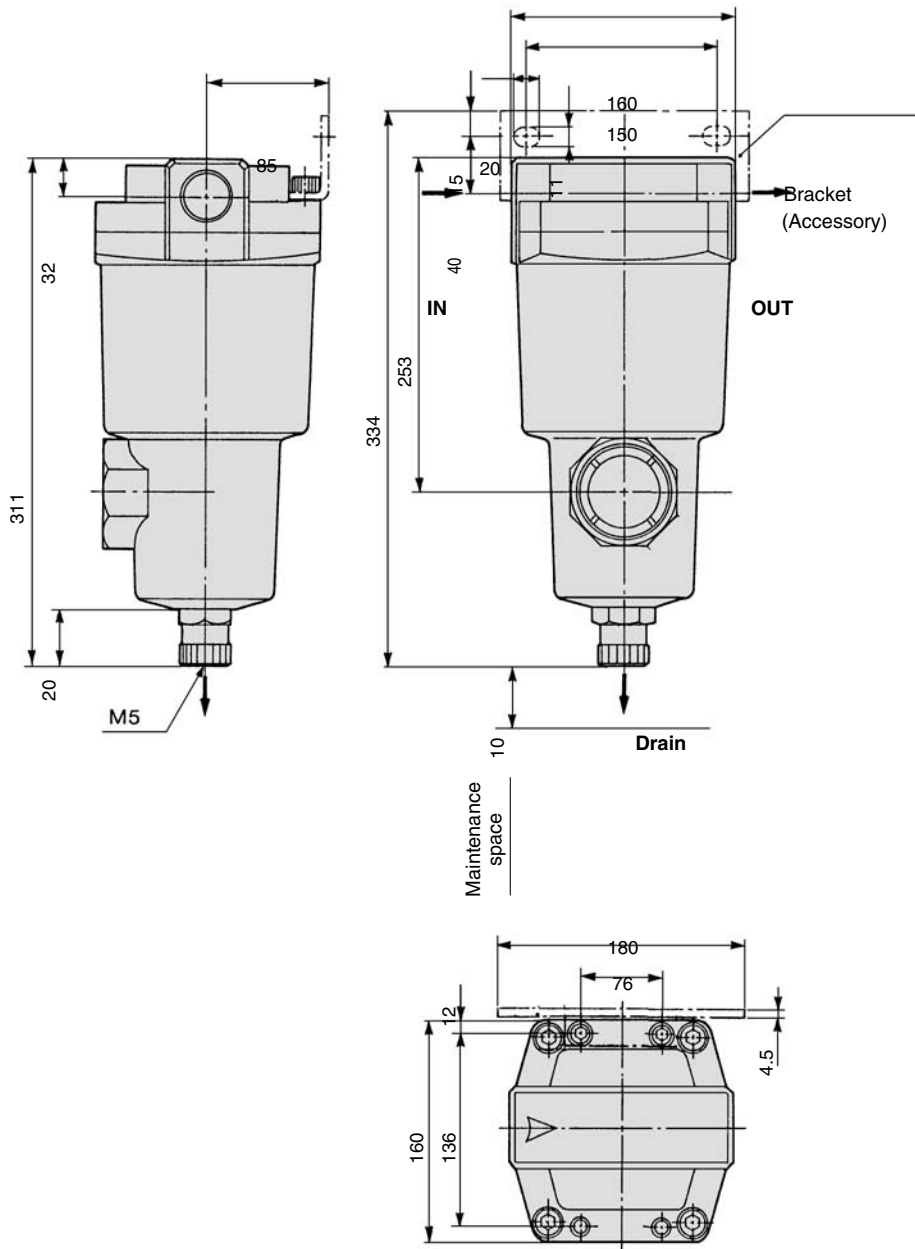

**Auto drain**

**D: With auto drain (N.O.)**

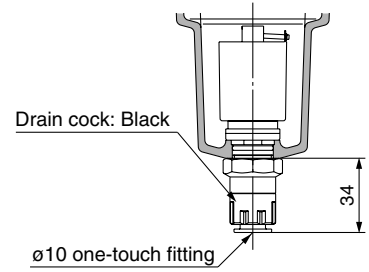

**Option**

**J: Drain guide 1/4 female threaded**

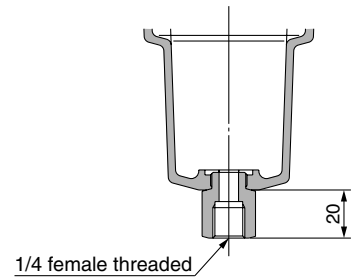

**T: With element service indicator**

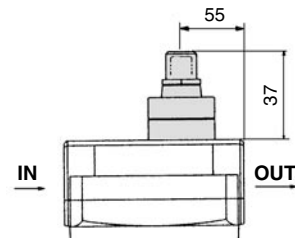

# Series AMD

## Dimensions

### AMD850

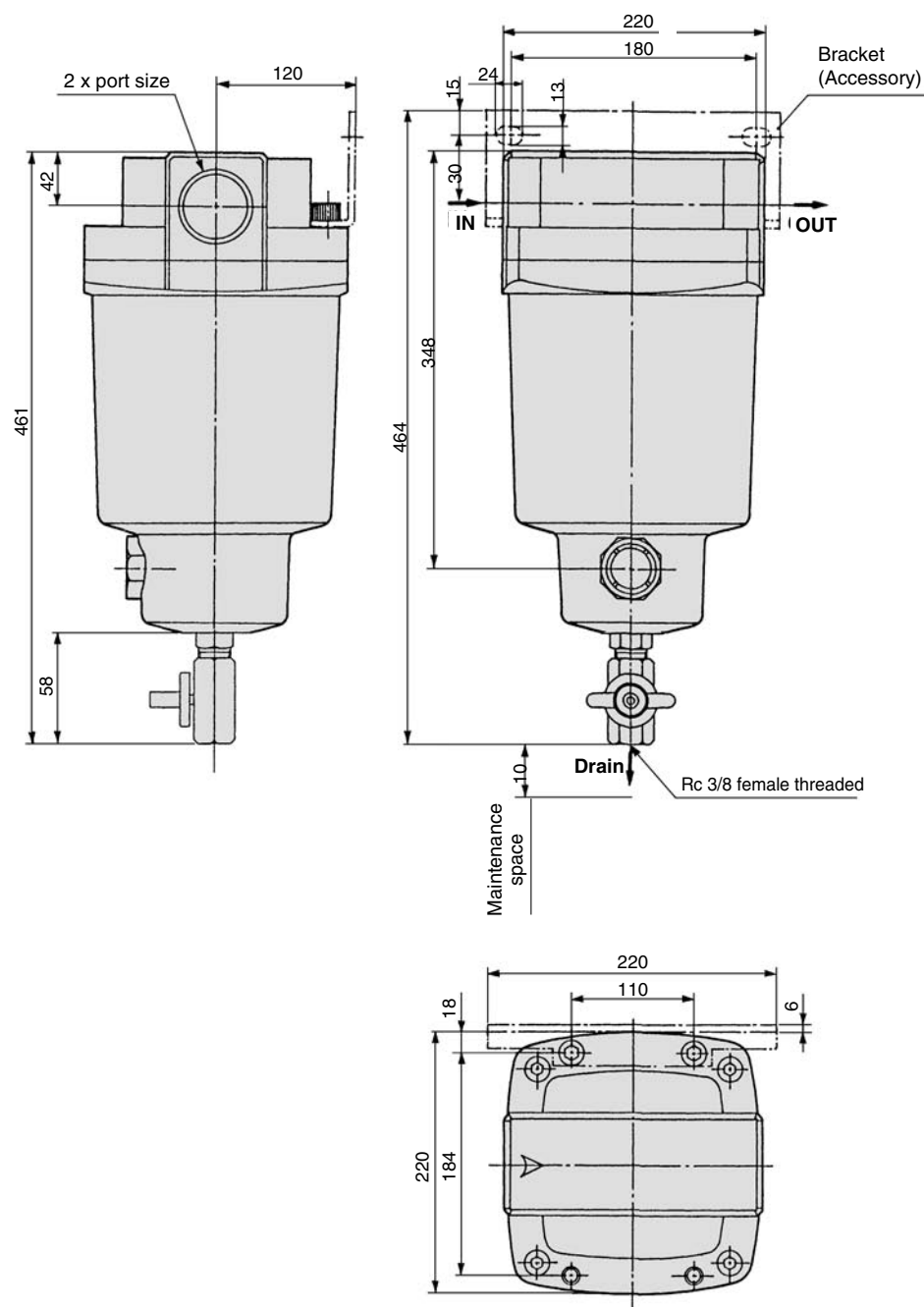

### Auto drain

D: With auto drain (N.O.)  
for AMD850

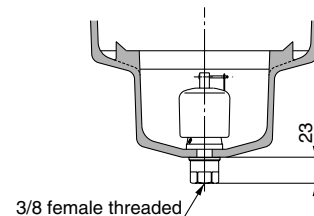

### Option

T: With element service indicator

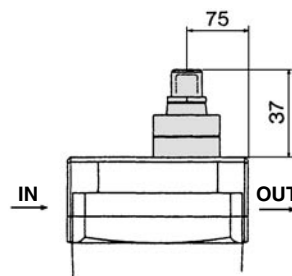

# Micro Mist Separator with Pre-filter

## Series AMH

Can separate and remove aerosol state oil mist in compressed air and remove particles such as carbon or dust of more than 0.01  $\mu\text{m}$ .

Use this product as a pre-filter for compressed air for precision instruments or clean room requiring higher clean air.

The conventional pneumatic pressure line, AM series + AMD series have been integrated to achieve a reduction in installation space and in piping labor.

Modular connection is possible with AMH150C to 550C. (For details, refer to page 58.)



AMH150C to 550C



AMH650/850

Symbol

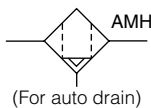
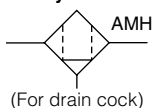

Made to Order  
(For details, refer to page 63.)

### Model

Model	AMH150C	AMH250C	AMH350C	AMH450C	AMH550C	AMH650	AMH850
Rated flow (Note) ( $\ell/\text{min}$ (ANR))	200	500	1000	2000	3700	6000	12000
Port size	1/8, 1/4	1/4, 3/8	3/8, 1/2	1/2, 3/4	3/4, 1	1, 1 1/2	1 1/2, 2
Mass (kg)	0.38	0.55	0.9	1.4	2.1	4.2	10.5



Note) Max. flow at 0.7 MPa.

Max. flow varies depending on the operating pressure.

Refer to "Flow Characteristics" (page 37) and "Maximum Air Flow" below.

### Specifications

Fluid	Compressed air
Max. operating pressure	1.0 MPa
Min. operating pressure*	0.05 MPa
Proof pressure	1.5 MPa
Ambient and fluid temperature	5 to 60°C
Nominal filtration density	0.01 $\mu\text{m}$ (Filtration efficiency: 99.9%)
Oil mist density at outlet	Max. 0.1 $\text{mg}/\text{m}^3$ (ANR)* (Before saturated with oil, less than 0.01 $\text{mg}/\text{m}^3$ (ANR) $\approx$ 0.008 ppm)
Element life	2 years or when pressure drop reached 0.1 MPa

\* With auto drain: 0.1 MPa (N.O. type) or 0.15 MPa (N.C. type)

\* Oil mist density at 30  $\text{mg}/\text{m}^3$  (ANR) blown out by compressor.

### Accessory

Applicable model	AMH150C	AMH250C	AMH350C	AMH450C	AMH550C	AMH650	AMH850
Bracket assembly (with 2 mounting screws)	AM-BM101	AM-BM102	AM-BM103	AM-BM104	AM-BM105	BM56	BM57

### Model Selection

Select a model in accordance with the following procedure taking the inlet pressure and the max. air flow rate into consideration.

(Example) Inlet pressure: 0.6 MPa  
Max. air flow rate: 5  $\text{m}^3/\text{min}$  (ANR)

1. Obtain the intersecting point A of inlet pressure and max. air flow rate in the graph.
2. The AMH650 is obtained when the max. flow line is above the intersecting point A in the graph.



Note) Make sure to select a model that has the max. flow line above the obtained intersecting point. With a model that has the max. flow line below the obtained intersecting point, the flow rate will be exceeded, thus leading to a problem such as being unable to satisfy the specifications.

### Maximum Air Flow

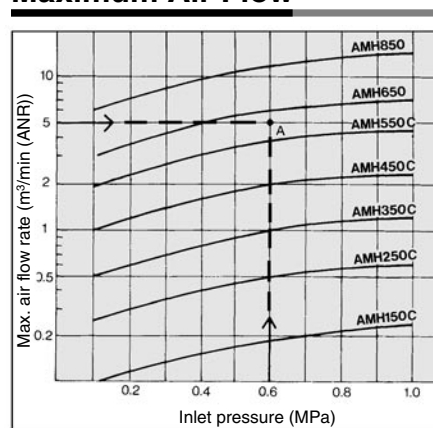

### Caution

Be sure to read this before handling.  
Refer to back pages 1 and 2 for Safety Instructions, "Precautions for Handling Pneumatic Devices" (M-03-E3A) for Common Precautions, and back pages 3 through to 7 for Specific Product Precautions.

## How to Order



### AMH150C to 550C

AMH **550C** - [ ] **10** [ ] [ ] - [ ] - [ ]

#### Body size

150C
250C
350C
450C
550C

#### Thread type

Symbol	Type
—	Rc
F	G*1
N	NPT

\*1 Conforms to ISO1179-1.

#### Port size

Symbol	Size	Applicable body size				
		150C	250C	350C	450C	550C
01	1/8	●				
02	1/4	●	●			
03	3/8		●	●		
04	1/2			●	●	
06	3/4				●	●
10	1					●

#### Accessory

Symbol	Description
—	—
B	Bracket *2

\*2 Bracket is included, (but not assembled).

### Auto Drain Specifications/Option Combinations

○ : All draining specifications are available (including drain guide, J type).  
 △ : N.C. auto drain (C type) is not available.  
 ▼ : N.C. auto drain (C type) and N.O. auto drain (D type) are not available.

	—	F	H	R	S	U	T	V
—	○	○	△	○				○
F	○	○	▼	○				▼
H	△	▼	△	△				▼
R	○	○	△					○
S								
U	Note			Note				
T								○
V	○	▼	▼	○			○	

Note) one of them selectable    ◻ : Not available

#### Made to Order

("How to Order" and the applicable models are different from those shown on this page. Be sure to refer to "Made to Order".)

Symbol	Description	Page for details
—	—	—
X6	With differential pressure gauge (GD40-2-01)	P.64
X26	N.C., N.O. auto drain, drain piping type	P.65

#### Option \*3

Symbol	Description
—	—
F	Rubber material: Fluororubber
H	For medium air pressure (1.6 MPa)
J	Drain guide 1/4 female threaded *4
R	IN-OUT reversal direction
U	With differential pressure switch (30 VDC) *5
T	With element service indicator
V	Degreasing wash, *6 white vaseline

\*4 Drain piping and piping for a stop valve such as ball valve are required.

\*5 Differential pressure switch is included, (but not assembled).

\*6 Only body/housing is degreasing washed.

#### Auto drain \*3

Symbol	Description
—	Drain cock (Without auto drain)
C	N.C. auto drain
D	N.O. auto drain

\*3 Refer to the table below for the combination between the draining specification and option. (Only one draining specification is selectable).

## Options

**Symbol F: Rubber material: Fluororubber**

Fluororubber is used for the parts such as O-ring and gasket.

**Symbol H: For medium air pressure (1.6 MPa)**

Can be used up to 1.6 MPa at maximum.

**Symbol J: Drain guide 1/4 female threaded**

Can be piped to the drain exhaust port.

1/4 female threaded

**Symbol R: IN-OUT reversal direction**

Air flow in the separator is changed to right to left. (Air flow direction of the standard: Left to right.)

**Symbol U: With differential pressure switch (with indicator)**

Saturation of the separator can be observed visually or by an electrical signal. (Element life check)

**Symbol T: With element service indicator**

Saturation of the separator can be observed visually. (Element life check)

Pressure drop 0.1 MPa

Max. contact capacity: 10 W DC  
 Rated contact voltage (max. operating current): 30 V DC (0.33 A)

Reed switch

**Symbol V: Degreasing wash, white vaseline**

Body/housing is degreasing washed. The lubrication grease for O-ring and gasket is changed to white vaseline.



## How to Order

### AMH650/850

AMH **650** - [ ] [ ] [ ] - [ ] - [ ]

#### Body size

650
850

#### Thread type

Symbol	Type
—	Rc
F	G
N	NPT

#### Port size

Symbol	Size	Applicable body size	
		650	850
10	1	●	—
14	1 1/2	●	●
20	2	—	●

#### Accessory

Symbol	Description
—	—
B	Bracket *2

\*2 Bracket is included, (but not assembled).

#### Made to Order

("How to Order" and the applicable models are different from those shown on this page. Be sure to refer to "Made to Order".)

Symbol	Description	Page for details
—	—	—
X6	With differential pressure gauge (GD40-2-01)	P.64
X26	N.C., N.O. auto drain, drain piping type	P.65
X12	White vaseline specifications	P.65

#### Option \*2

Symbol	Description
—	—
J	Drain guide 1/4 female threaded *4
R	IN-OUT reversal direction
T	With element service indicator

\*4 Drain piping and piping for a stop valve such as ball valve are required.

#### Auto drain \*2

Symbol	Description
—	Drain cock (Without auto drain) *3
D	N.O. auto drain

\*2 Refer to "Auto Drain Specifications/Option Combinations".

\*3 Body size 850 is equipped with a ball valve (Rc3/8 female threaded). Mount a piping adapter IDF-AP609 (page 58) to the ball valve if NPT3/8 female threaded is required.



Note) Refer to "How to Order Bowl Assembly" on page 59.

### Auto Drain Specifications/Option Combinations

○: Available    □: Not available

Auto drain specifications/Option			Auto drain specifications		Option			Applicable model	
			D	J	R	T	AMH650	AMH850	
Auto drain specifications	N.O. auto drain	D	□	□	○	○	○	○	
	Drain guide 1/4	J	□	□	○	○	○	○	
Option	IN-OUT reversal direction	R	○	○	□	○	○	○	
	With element service indicator	T	○	○	○	□	○	○	

# Series AMH

## Flow Characteristics/Select the model taking the max. flow capacity into consideration. (—— Element oil saturation ---- Initial condition)



Note) Compressed air over max. flow line in the table below may not meet the specifications of the product. It may cause damage to the element.

**AMH150C**

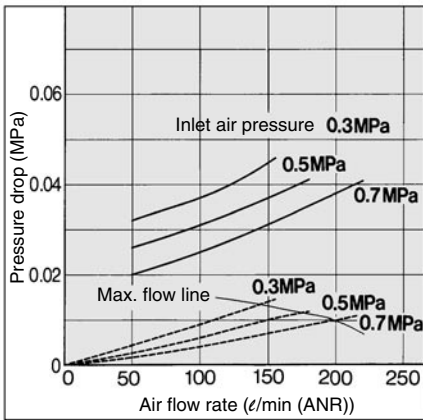

**AMH450C**

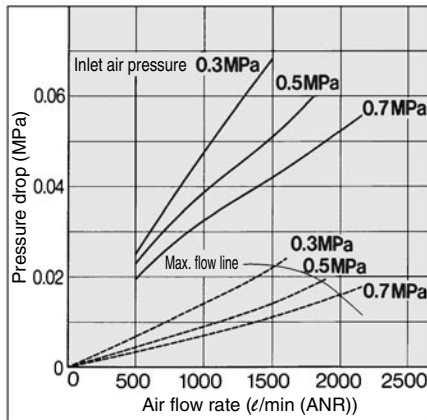

**AMH850**

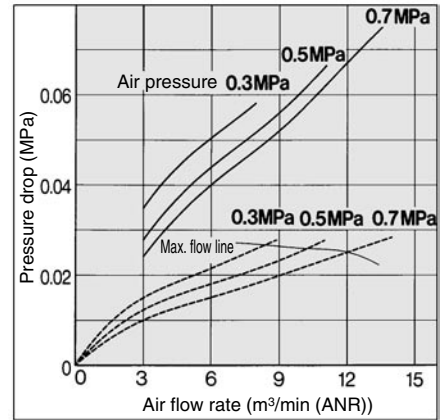

**AMH250C**

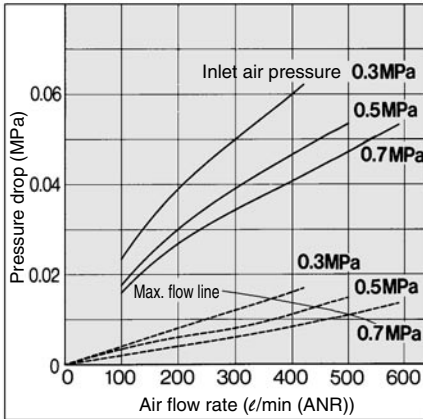

**AMH550C**

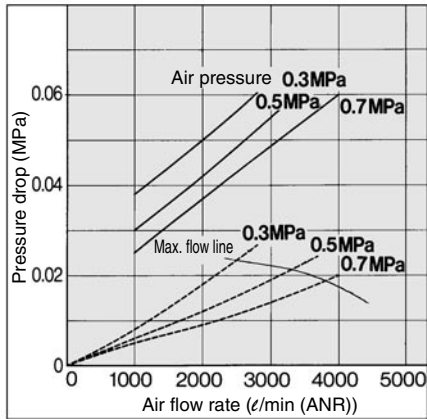

**AMH350C**

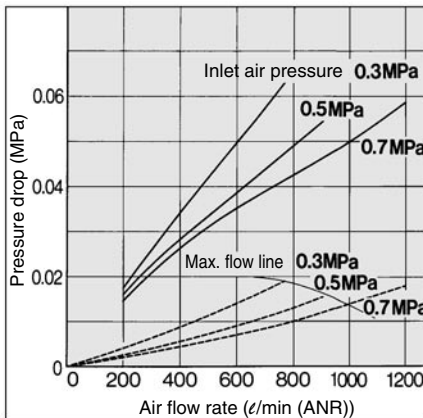

**AMH650**

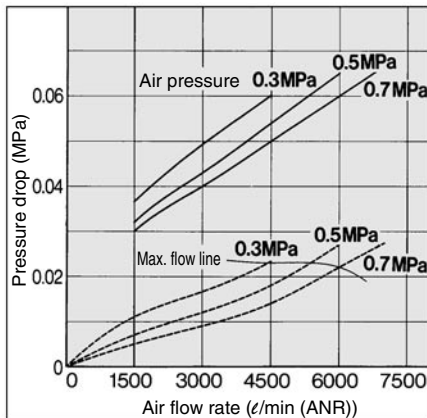



## Construction

### AMH150C to 550C, AMH650

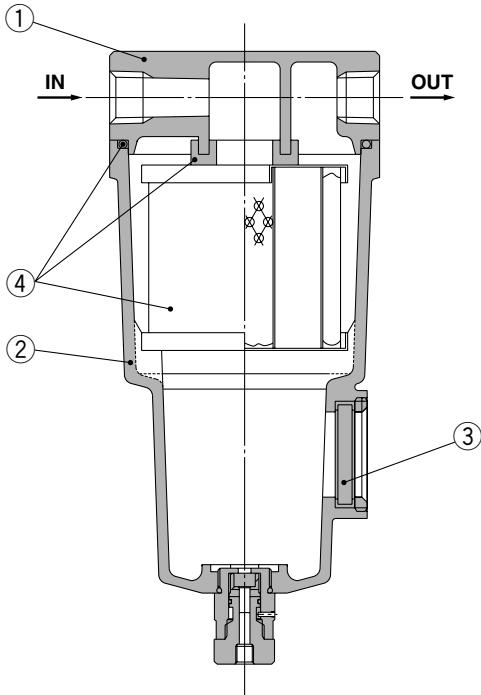

### AMH850

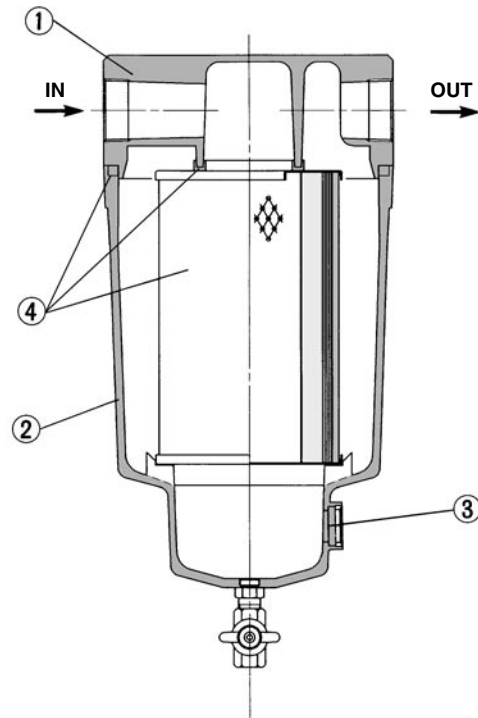

## Component Parts

No.	Description	Material	Note
1	<b>Body</b>	Aluminum die-casted	Chrome treated
2	<b>Housing</b>	Aluminum die-casted*	Epoxy coating on inner surface
3	<b>Sight glass</b>	Tempered glass	—

\* The AMH850 is aluminum casted.



Note) Refer to "How to Order Bowl Assembly" on page 59.



Note) Sight glass is indicated in the figure for easy understanding of component parts. However, it differs from the actual construction. Refer to dimensions on pages 39 through to 41 for details.

## Replacement Parts

No.	Description	Material	Applicable model	Model						
				AMH150C	AMH250C	AMH350C	AMH450C	AMH550C	AMH650	AMH850
4	<b>Element assembly</b>	Glass fiber, others	Except option F	AMH-EL150	AMH-EL250	AMH-EL350	AMH-EL450	AMH-EL550	AMH-EL650	AMH-EL850
			For option F	AMH-EL150-F	AMH-EL250-F	AMH-EL350-F	AMH-EL450-F	AMH-EL550-F	—	—

\* Element assembly: With gasket (1 pc.) and O-ring (1 pc.)

\* Refer to back page 6 for replacement of auto drain.

\* Element assemblies for Made to Order (X6, X12, X20, X26) are same as those for standard (see the above table).

# Series AMH

## Dimensions

### AMH150C to 550C

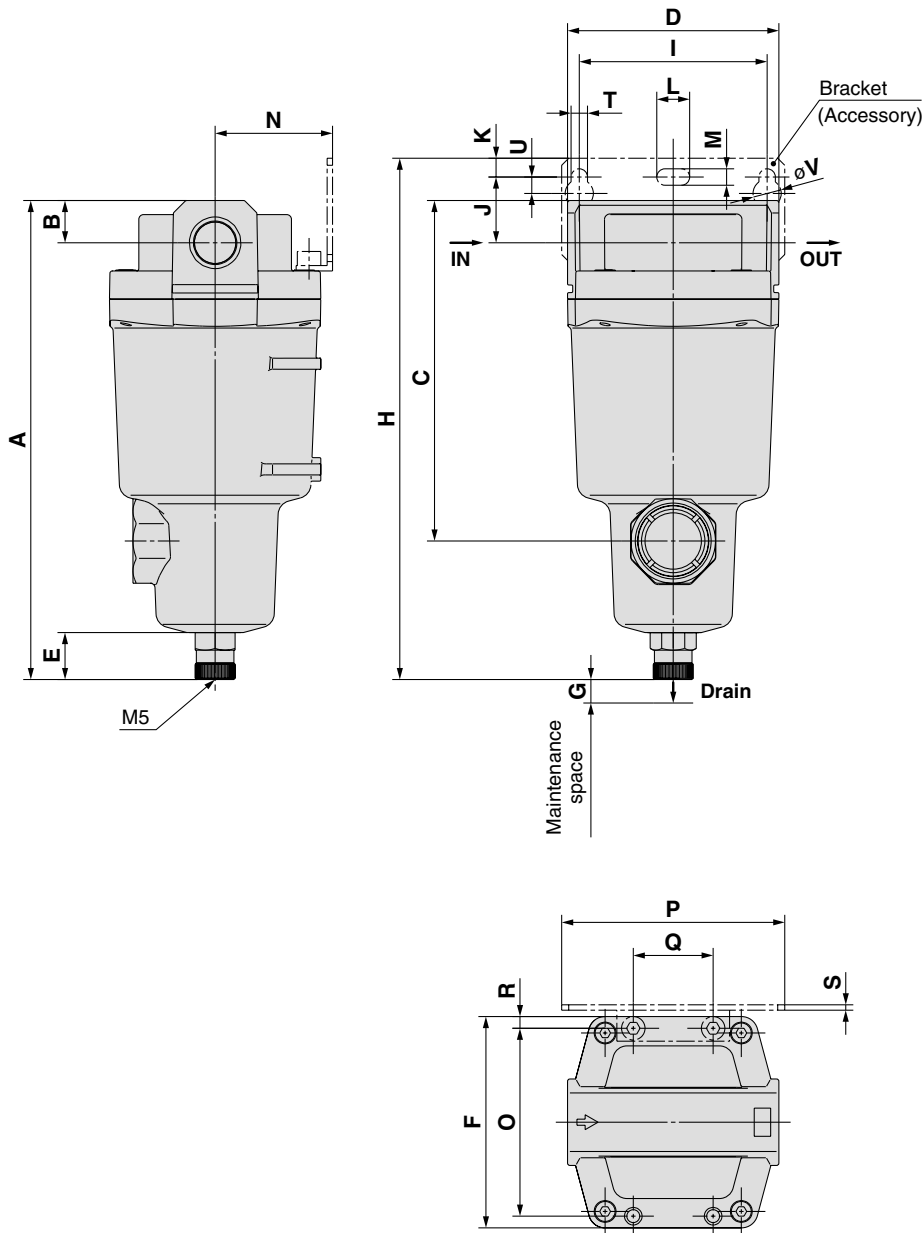

### Auto drain

**C:** With auto drain (N.C.)  
**D:** With auto drain (N.O.)

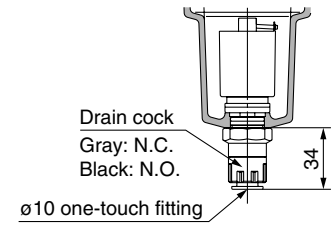

**Combination of D:** With auto drain (N.O.)  
**and H:** For medium air pressure

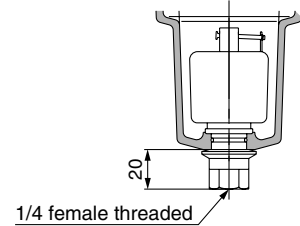

### Option

**J:** Drain guide 1/4 female threaded

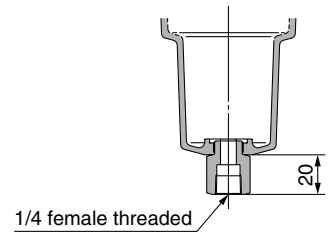

**U:** With differential pressure switch (with indicator)

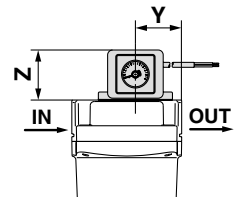

**T:** With element service indicator

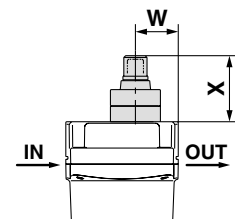

Model	Port size	A	B	C	D	E	F	G	Bracket related dimensions													Element service indicator related dimensions		Differential pressure switch related dimensions			
									H	I	J	K	T	U	L	M	V	N	O	P	Q	R	S	W	X	Y	Z
AMH150C	1/8, 1/4	158	10	99	63	20	63	10	173	56	20	5	6	6	12	6	10	35	54	70	26	4.5	1.6	24	37	32	41
AMH250C	1/4, 3/8	172	14	113	76	20	76	10	190	66	24	8	6	6	12	6	10	40	66	80	28	5	2	27	37	36	41
AMH350C	3/8, 1/2	204	18	145	90	20	90	10	222	80	28	8	7	7	14	7	12	50	80	95	34	5	2.3	32	37	42	41
AMH450C	1/2, 3/4	225	20	166	106	20	106	10	246	90	31	10	9	9	18	9	15	55	88	111	50	9	3.2	37	37	43	41
AMH550C	3/4, 1	259	24	200	122	20	122	15	278	100	33	10	9	9	18	9	15	65	102	126	60	10	3.2	39	37	51	41

**Dimensions**

**AMH650**

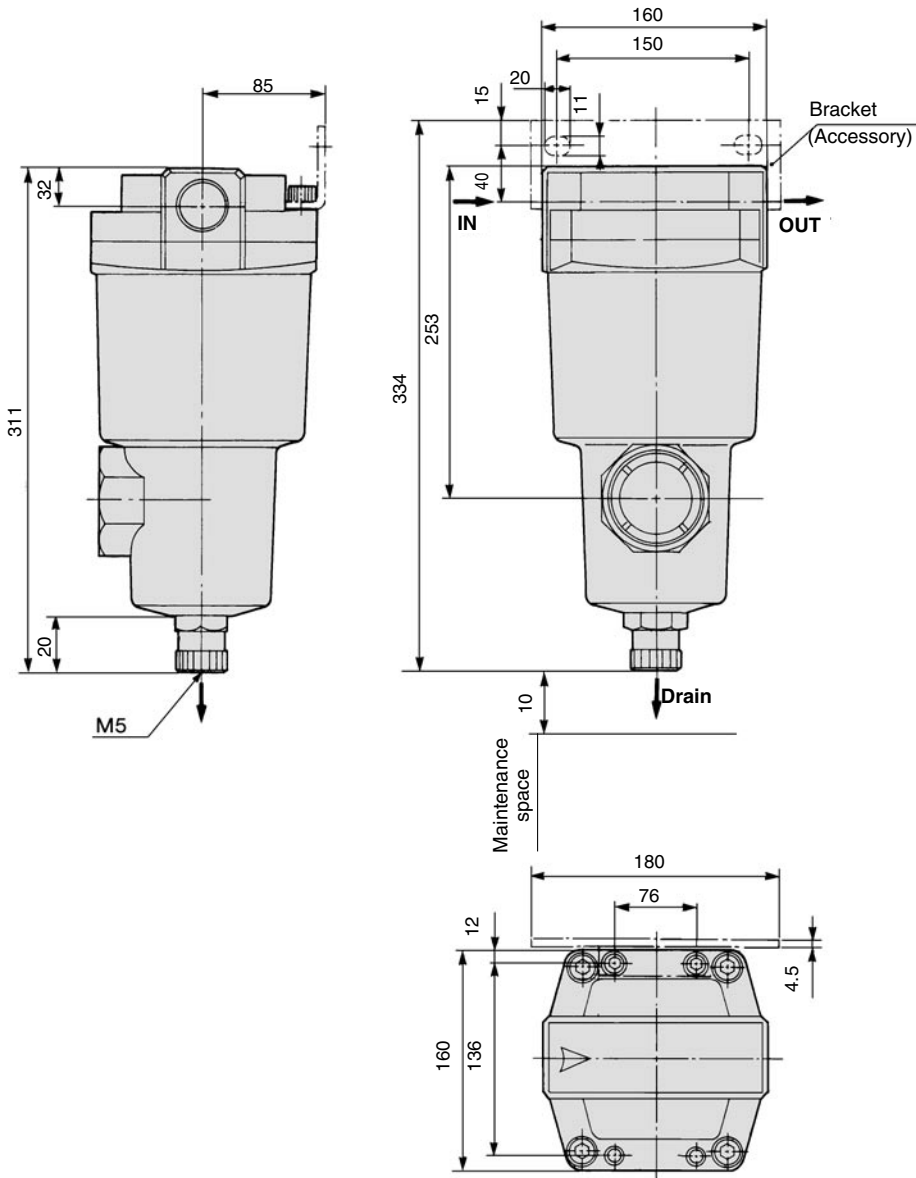

**Auto drain**

**D: With auto drain (N.O.)**

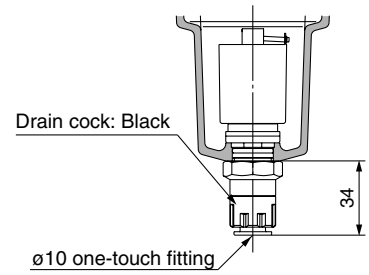

**Option**

**J: Drain guide 1/4 female threaded**

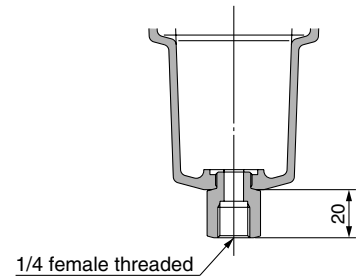

**T: With element service indicator**

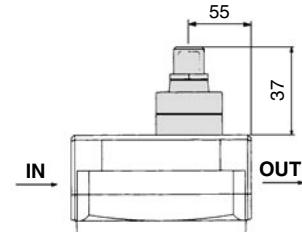

# Series AMH

## Dimensions

### AMH850

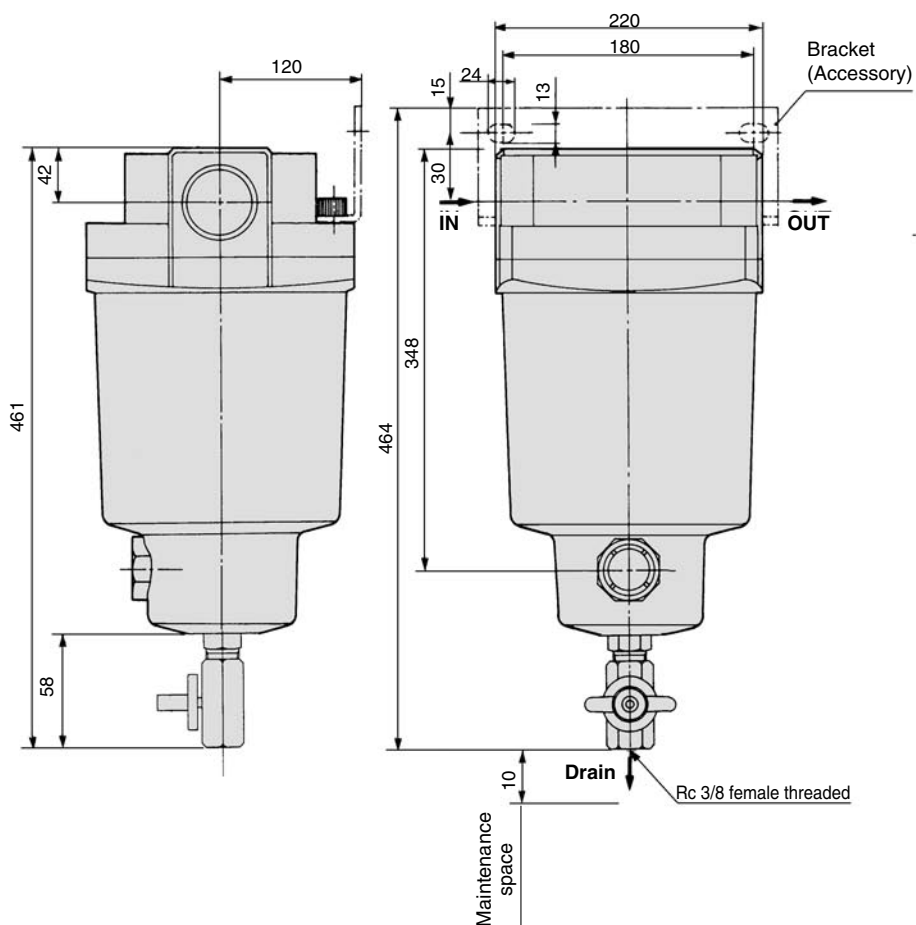

### Auto drain

D: With auto drain (N.O.)  
for AMH850

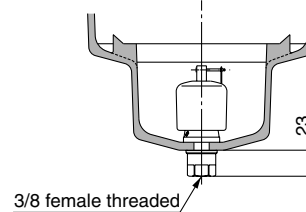

### Option

T: With element service indicator

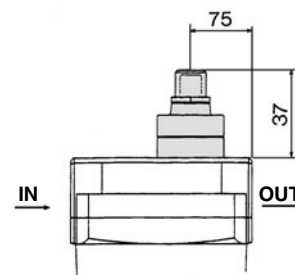

# Super Mist Separator Series **AME**

Can separate and adsorb aerosol state fine oil particles in compressed air and change the oil lubricating compressed air to oilless air or equivalent.

Use this product for filtration of compressed air requiring higher clean air for painting lines, compressed air for clean rooms and/or equipment where oils must be avoided.

Indicates the filter element life by a colour change. Accordingly, the replacement time can be judged visually. (A red colour spot indicates the replacement time.)

## ⚠ Caution

By all means the "AM" series should be used as a pre-filter.

Modular connection is possible with AME150C to 550C. (For details, refer to page 58.)



AME150C to 350C AME450C/550C



AME650/850

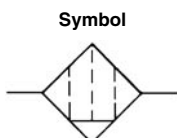

**Made to Order**  
(For details, refer to page 63.)

## Model

Model	AME150C	AME250C	AME350C	AME450C	AME550C	AME650	AME850
Rated flow (ℓ/min (ANR)) <small>Note)</small>	200	500	1000	2000	3700	6000	12000
Port size	1/8, 1/4	1/4, 3/8	3/8, 1/2	1/2, 3/4	3/4, 1	1, 1 1/2	1 1/2, 2
Mass (kg)	0.3	0.48	0.8	1.3	2.0	4.2	10.5



Note) Max. flow at 0.7 MPa.

Max. flow varies depending on the operating pressure.

Refer to "Flow Characteristics" (page 45) and "Maximum Air Flow" (page 45).

## Specifications

Fluid	Compressed air
Max. operating pressure	1.0 MPa
Min. operating pressure	0.05 MPa
Proof pressure	1.5 MPa
Ambient and fluid temperature	5 to 60°C
Nominal filtration rating	0.01 μm (Filtration efficiency: 99.9%)
Cleanliness at outlet	Less than 100 particles of 0.3 μm or larger per cubic foot [Less than 35 particles per 10 liters (ANR)]
Oil mist density at outlet	Max. 0.01 mg/m <sup>3</sup> (ANR) (≈0.008 ppm)
Life of element	1. Element color check window (If the element is found to have red spots, replace it immediately.) 2. Even if the element does not have red spots, when the pressure drop reaches 0.1MPa or 2 years has passed in operation, whichever comes the first, perform replacement.

## Accessory

Applicable model	AME150C	AME250C	AME350C	AME450C	AME550C	AME650	AME850
Bracket assembly (with 2 mounting screws)	AM-BM101	AM-BM102	AM-BM103	AM-BM104	AM-BM105	BM56	BM57

## ⚠ Caution

Be sure to read this before handling.  
Refer to back pages 1 and 2 for Safety Instructions, "Precautions for Handling Pneumatic Devices" (M-03-E3A) for Common Precautions, and back pages 3 through to 7 for Specific Product Precautions.

## How to Order



### AME150C to 550C

AME **550C** - [ ] **10** [ ] - [ ]

#### Body size

150C
250C
350C
450C
550C

#### Thread type

Symbol	Type
—	Rc
<b>F</b>	G* <sup>1</sup>
<b>N</b>	NPT

\*1 Conforms to ISO1179-1.

#### Option

Symbol	Description
—	—
<b>F</b>	Rubber material: Fluororubber
<b>H</b>	For medium air pressure (1.6 MPa)
<b>R</b>	IN-OUT reversal direction
<b>V</b>	Degreasing wash, * <sup>3</sup> white vaseline

\*3 Only body/housing is degreasing washed.

#### Accessory

Symbol	Description
—	—
<b>B</b>	Bracket * <sup>2</sup>

\*2 Bracket is included, (but not assembled).

#### Port size

Symbol	Size	Applicable body size				
		150C	250C	350C	450C	550C
<b>01</b>	1/8	●				
<b>02</b>	1/4	●	●			
<b>03</b>	3/8		●	●		
<b>04</b>	1/2			●	●	
<b>06</b>	3/4				●	●
<b>10</b>	1					●

## Options

#### Symbol F: Rubber material: Fluororubber

Fluororubber is used for the parts such as O-ring and gasket.

#### Symbol H: For medium air pressure (1.6 MPa)

Can be used up to 1.6 MPa at maximum.

#### Symbol R: IN-OUT reversal direction

Air flow in the separator is changed to right to left.  
(Air flow direction of the standard: Left to right.)

#### Symbol V: Degreasing wash, white vaseline

Body/housing is degreasing washed. The lubrication grease for O-ring and gasket is changed to white vaseline.



## How to Order

### AME650/850

AME **650** - [ ] **10** [ ] - [ ] - [ ]

• **Body size**

650
850

• **Thread type**

Symbol	Type
—	Rc
<b>F</b>	G
<b>N</b>	NPT

• **Port size**

Symbol	Size	Applicable body size	
		650	850
<b>10</b>	1	●	—
<b>14</b>	1 1/2	●	●
<b>20</b>	2	—	●

• **Made to Order**

("How to Order" and the applicable models are different from those shown on this page. Be sure to refer to the page "Made to Order".)

Symbol	Description	Page for details
—	—	—
<b>X12</b>	White vaseline specifications	P.65

• **Option**

Symbol	Description
—	—
<b>R</b>	IN-OUT reversal direction

• **Accessory**

Symbol	Description
—	—
<b>B</b>	Bracket*

\* Bracket is included, (but not assembled).



Note) Refer to "How to Order Bowl Assembly" on page 59.

# Series AME

## Flow Characteristics (Element initial condition)



Note) Compressed air over max. flow line in the table below may not meet the specifications of the product. It may cause damage to the element.

### AME150C

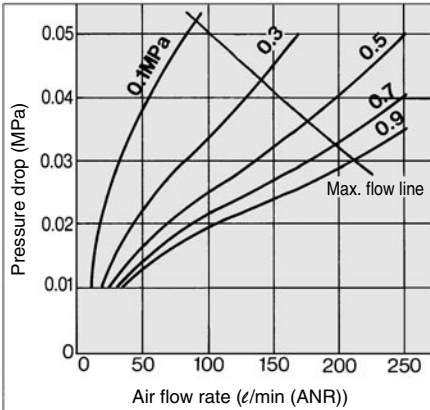

### AME450C

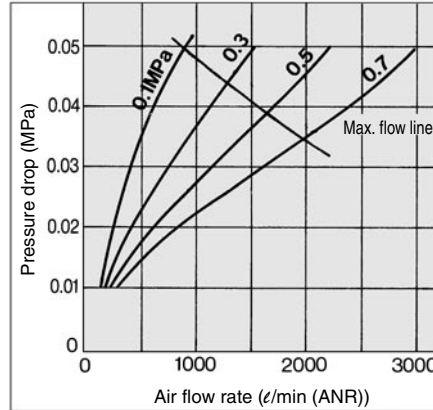

### AME650

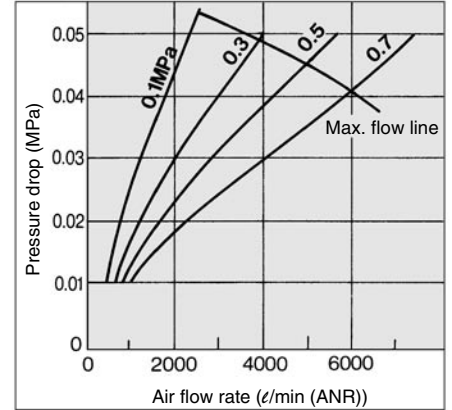

### AME250C

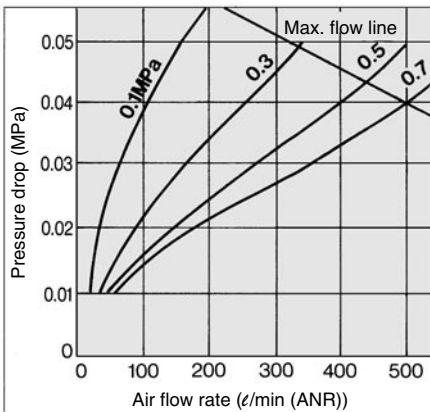

### AME550C

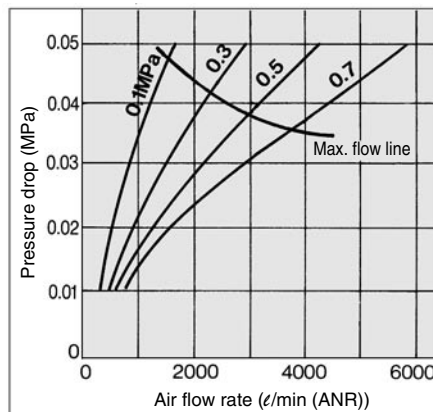

### AME850

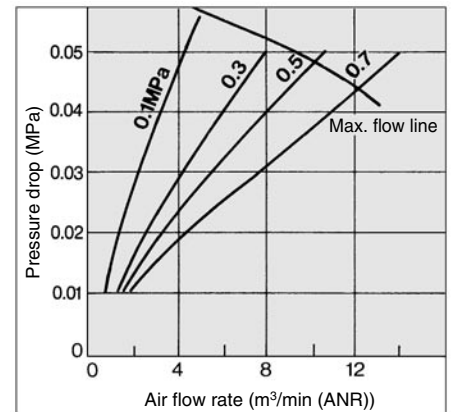

### AME350C

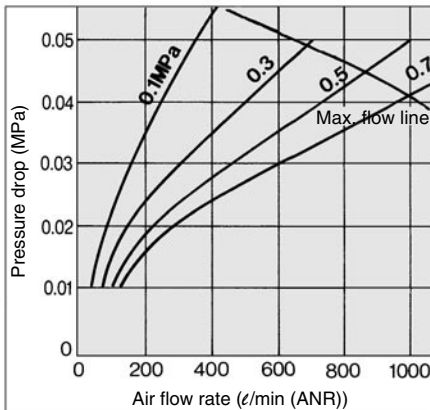

## Maximum Air Flow

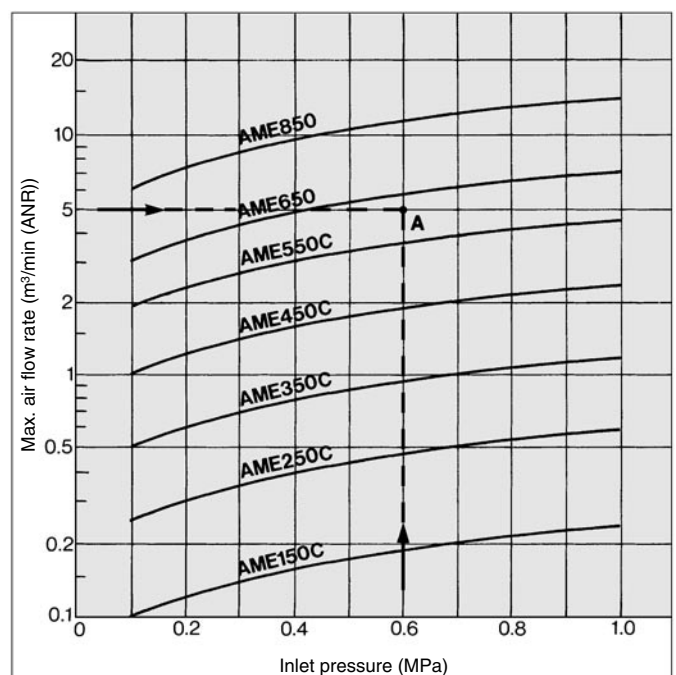

## Model Selection

Select a model in accordance with the following procedure taking the inlet pressure and the max. air flow rate into consideration.

(Example) Inlet pressure: 0.6 MPa  
Max. air flow rate: 5 m<sup>3</sup>/min (ANR)

1. Obtain the intersecting point A of inlet pressure and max. air flow rate in the graph.
2. The AME650 is obtained when the max. flow line is above the intersecting point A in the graph.



Note) Make sure to select a model that has the max. flow line above the obtained intersecting point. With a model that has the max. flow line below the obtained intersecting point, the flow rate will be exceeded, thus leading to a problem such as being unable to satisfy the specifications.



**Construction**

**AME150C to 550C**

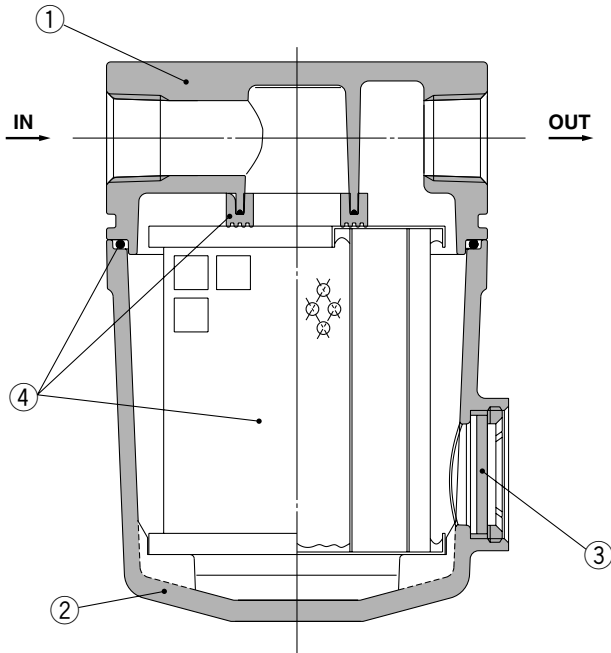

**AME650/850**

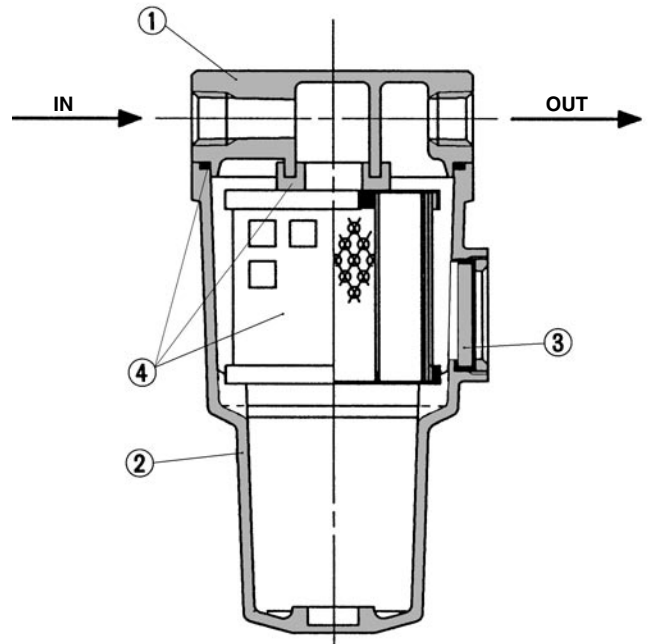

**Component Parts**

No.	Description	Material	Note
1	<b>Body</b>	Aluminum die-casted	Chrome treated
2	<b>Housing</b>	Aluminum die-casted*	Epoxy coating on inner surface
3	<b>Sight glass</b>	Tempered glass	—

\* The AME850 is aluminum casted.



Note) Refer to "How to Order Bowl Assembly" on page 59.



Note) Sight glass is indicated in the figure for easy understanding of component parts. However, it differs from the actual construction. Refer to dimensions on pages 47 through to 49 for details.

**Replacement Parts**

No.	Description	Material	Applicable model	Model						
				AME150C	AME250C	AME350C	AME450C	AME550C	AME650	AME850
4	<b>Element assembly</b>	Glass fiber, others	Except option F For option F	AME-EL150	AME-EL250	AME-EL350	AME-EL450	AME-EL550	AME-EL650	AME-EL850
				AME-EL150-F	AME-EL250-F	AME-EL350-F	AME-EL450-F	AME-EL550-F	—	—

\* Element assembly: With gasket (1 pc.) and O-ring (1 pc.)

\* Element assemblies for Made to Order (X12, X20) are same as those for standard (see the above table).

# Series AME

## Dimensions

### AME150C to 350C

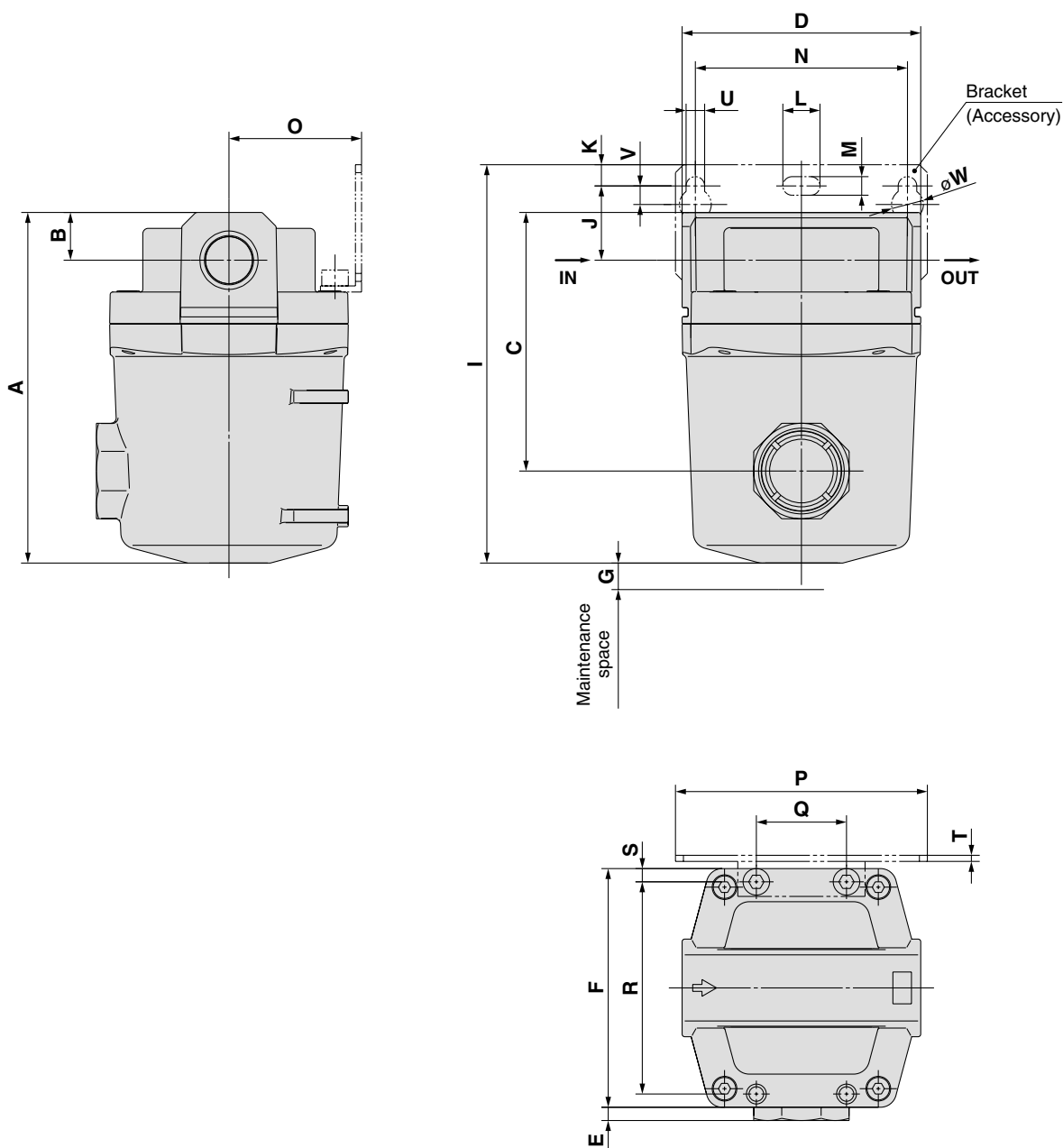

(mm)

Model	Port size	A	B	C	D	E	F	G	Bracket related dimensions														
									I	N	J	K	U	V	L	M	W	O	P	Q	R	S	T
<b>AME150C</b>	1/8, 1/4	83	10	54	63	7.5	63	10	98.5	56	20	5	6	6	12	6	10	35	70	26	54	4.5	1.6
<b>AME250C</b>	1/4, 3/8	103	14	73	76	5	76	10	121	66	24	8	6	6	12	6	10	40	80	28	66	5	2
<b>AME350C</b>	3/8, 1/2	132	18	98	90	5	90	10	150	80	28	8	7	7	14	7	12	50	95	34	80	5	2.3

**Dimensions**

**AME450C/550C**

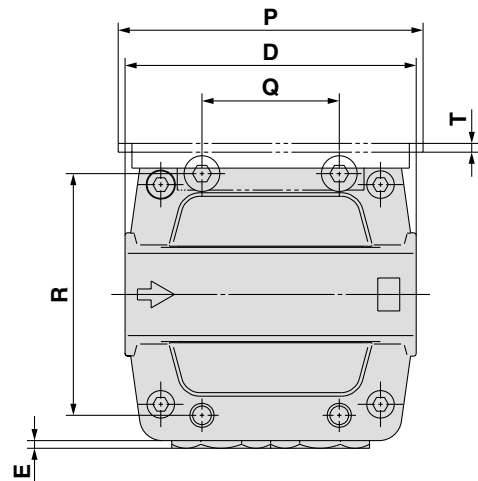
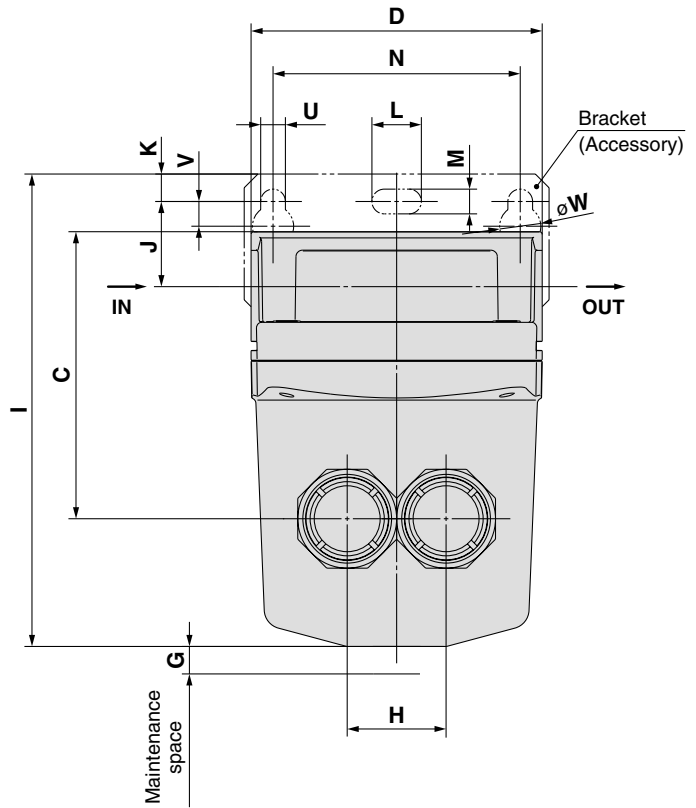
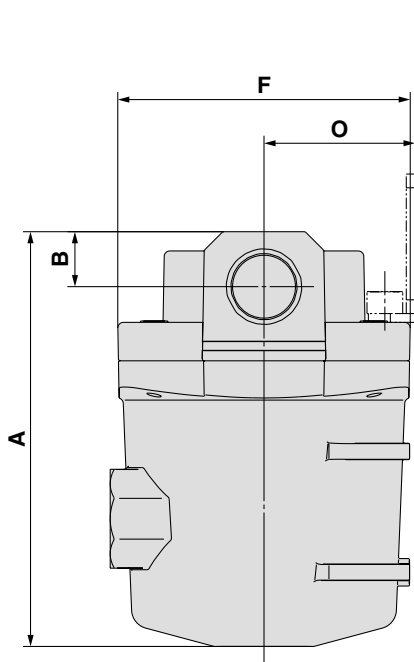

Model	Port size	A	B	C	D	E	F	G	H	Bracket related dimensions													
										I	N	J	K	U	V	L	M	W	O	P	Q	R	T
<b>AME450C</b>	1/2, 3/4	151	20	105	106	3	106	10	36	172	90	31	10	9	9	18	9	15	55	111	50	88	3.2
<b>AME550C</b>	3/4, 1	187	24	130	122	3	122	15	44	206	100	33	10	9	9	18	9	15	65	126	60	102	3.2

(mm)

# Series AME

## Dimensions

### AME650/850

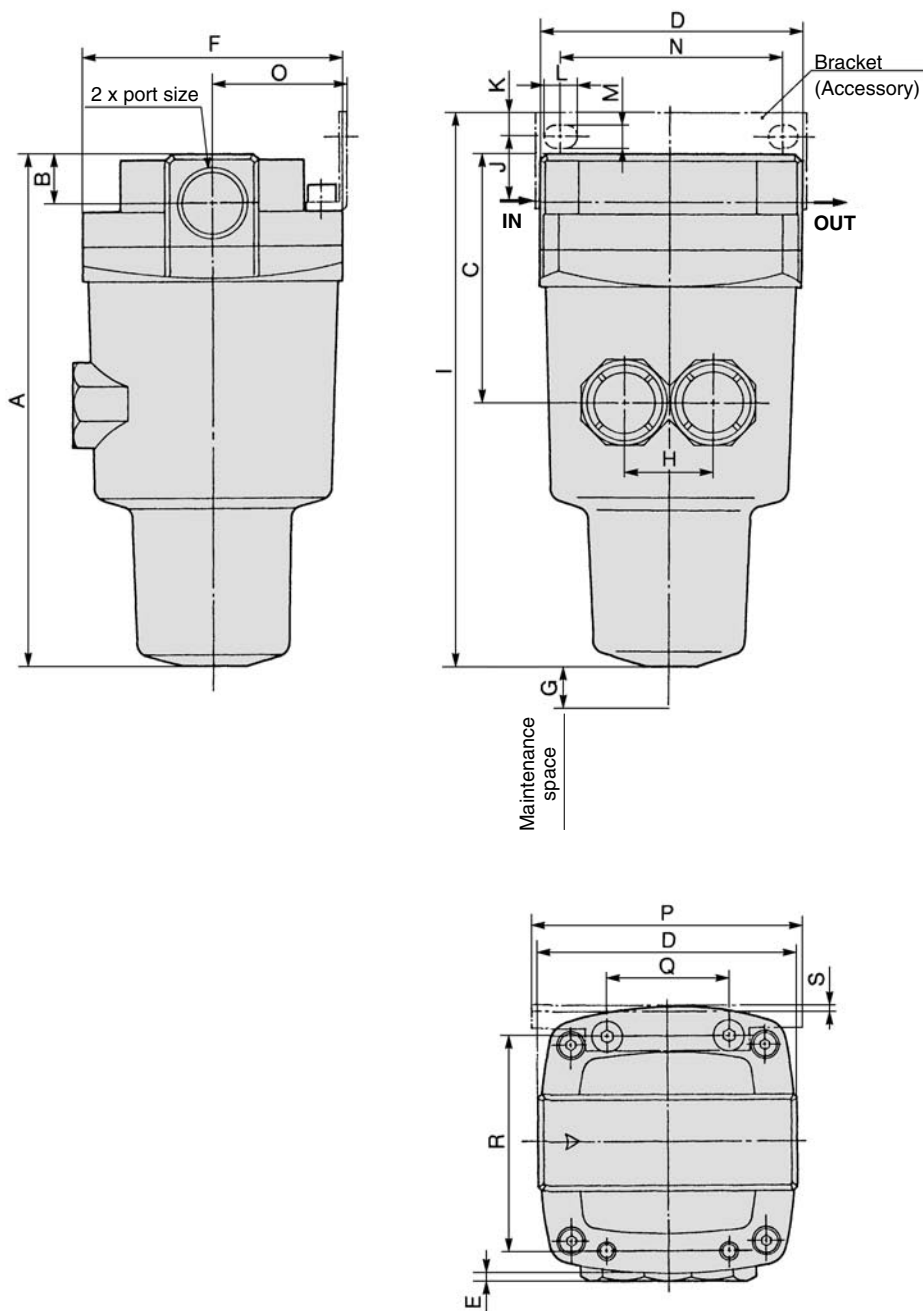

Model	Port size	A	B	C	D	E	F	G	H	Bracket related dimensions										
										I	J	K	L	M	N	O	P	Q	R	S
AME650	1, 1½	291	32	167	160	—	160	10	66	314	40	15	20	11	150	85	180	76	136	4.5
AME850	1½, 2	403	42	235	220	—	220	10	96	406	30	15	24	13	180	120	220	110	184	6

# Odour Removal Filter Series *AMF*

Efficiently can remove odour in compressed air with an activated carbon element. The unit is designed for use in the area such as a clean room where odours must be avoided. Can remove odour and gas ingredients in compressed air. Activated carbon element with large filtration area. Easy replacement of elements.

Modular connection is possible with AMF150C to 550C.  
(For details, refer to page 58.)



AMF150C to 350C AMF450C/550C



AMF650/850

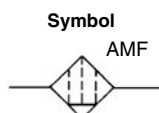

**Made to Order**  
(For details, refer to page 63.)

## Model

Model	AMF150C	AMF250C	AMF350C	AMF450C	AMF550C	AMF650	AMF850
Rated flow (ℓ/min (ANR)) <small>Note)</small>	200	500	1000	2000	3700	6000	12000
Port size	1/8, 1/4	1/4, 3/8	3/8, 1/2	1/2, 3/4	3/4, 1	1, 1 1/2	1 1/2, 2
Mass (kg)	0.3	0.48	0.8	1.3	2.0	4.2	10.5

Note) Max. flow at 0.7 MPa.  
Max. flow varies depending on the operating pressure.  
Refer to "Flow Characteristics" (page 53) and "Maximum Air Flow" (page 52).

## Specifications

Fluid	Compressed air
Max. operating pressure	1.0 MPa
Min. operating pressure	0.05 MPa
Proof pressure	1.5 MPa
Ambient and fluid temperature	5 to 60°C
Nominal filtration rating	0.01 μm (Filtration efficiency: 99.9%)
Cleanliness at outlet	Less than 100 particles of 0.3 μm or larger per cubic foot [Less than 35 particles per 10 liters (ANR)] (The "AME" series is required on the inlet side.)
Oil mist density at outlet	Max. 0.004 mg/m <sup>3</sup> (ANR) (≈0.0032 ppm) (The "AME" series is required on the inlet side.)
Life of element	1. Replace when the secondary side smells of oil. 2. Even if there is no decrease in deodorization performance, when the pressure drop reaches 0.1MPa or 2 years has passed, whichever comes early, perform replacement.

## Accessory (Option)

Applicable model	AMF150C	AMF250C	AMF350C	AMF450C	AMF550C	AMF650	AMF850
Bracket assembly (with 2 mounting screws)	AM-BM101	AM-BM102	AM-BM103	AM-BM104	AM-BM105	BM56	BM57

## Caution

Be sure to read this before handling.  
Refer to back pages 1 and 2 for Safety Instructions, "Precautions for Handling Pneumatic Devices" (M-03-E3A) for Common Precautions, and back pages 3 through to 7 for Specific Product Precautions.

## How to Order



### AMF150C to 550C

AMF **550C** - [ ] **10** [ ] - [ ]

#### Body size

150C
250C
350C
450C
550C

#### Thread type

Symbol	Type
—	Rc
<b>F</b>	G* <sup>1</sup>
<b>N</b>	NPT

\*1 Conforms to ISO1179-1.

#### Option

Symbol	Description
—	—
<b>F</b>	Rubber material: Fluororubber
<b>H</b>	For medium air pressure (1.6 MPa)
<b>R</b>	IN-OUT reversal direction
<b>V</b>	Degreasing wash, * <sup>3</sup> white vaseline

\*3 Only body/housing is degreasing washed.

#### Accessory

Symbol	Description
—	—
<b>B</b>	Bracket * <sup>2</sup>

\*2 Bracket is included, (but not assembled).

#### Port size

Symbol	Size	Applicable body size				
		150C	250C	350C	450C	550C
<b>01</b>	1/8	●				
<b>02</b>	1/4	●	●			
<b>03</b>	3/8		●	●		
<b>04</b>	1/2			●	●	
<b>06</b>	3/4				●	●
<b>10</b>	1					●

## Options

#### Symbol F: Rubber material: Fluororubber

Fluororubber is used for the parts such as O-ring and gasket.

#### Symbol H: For medium air pressure (1.6 MPa)

Can be used up to 1.6 MPa at maximum.

#### Symbol R: IN-OUT reversal direction

Air flow in the separator is changed to right to left.  
(Air flow direction of the standard: Left to right.)

#### Symbol V: Degreasing wash, white vaseline

Body/housing is degreasing washed. The lubrication grease for O-ring and gasket is changed to white vaseline.



## How to Order

### AMF650/850

AMF **650** - [ ] **10** - [ ] - [ ] - [ ]

**Body size**

650
850

**Thread type**

Symbol	Type
—	Rc
<b>F</b>	G
<b>N</b>	NPT

**Port size**

Symbol	Size	Applicable body size	
		650	850
<b>10</b>	1	●	—
<b>14</b>	1 1/2	●	●
<b>20</b>	2	—	●

**Made to Order**

("How to Order" and the applicable models are different from those shown on this page. Be sure to refer to "Made to Order".)

Symbol	Description	Page for details
—	—	—
<b>X12</b>	White vaseline specifications	P.65

**Option**

Symbol	Description
—	—
<b>R</b>	IN-OUT reversal direction

**Accessory**

Symbol	Description
—	—
<b>B</b>	Bracket*

\* Bracket is included, (but not assembled).



Note) Refer to "How to Order Bowl Assembly" on page 59.

## Model Selection

Select a model in accordance with the following procedure taking the inlet pressure and the max. air flow rate into consideration.

(Example) Inlet pressure: 0.6 MPa

Max. air flow rate: 5 m<sup>3</sup>/min (ANR)

1. Obtain the intersecting point A of inlet pressure and max. air flow rate in the graph.
2. The AMF650 is obtained when the max. flow line is above the intersecting point A in the graph.



Note) Make sure to select a model that has the max. flow line above the obtained intersecting point. With a model that has the max. flow line below the obtained intersecting point, the flow rate will be exceeded, thus leading to a problem such as being unable to satisfy the specifications.

## Maximum Air Flow

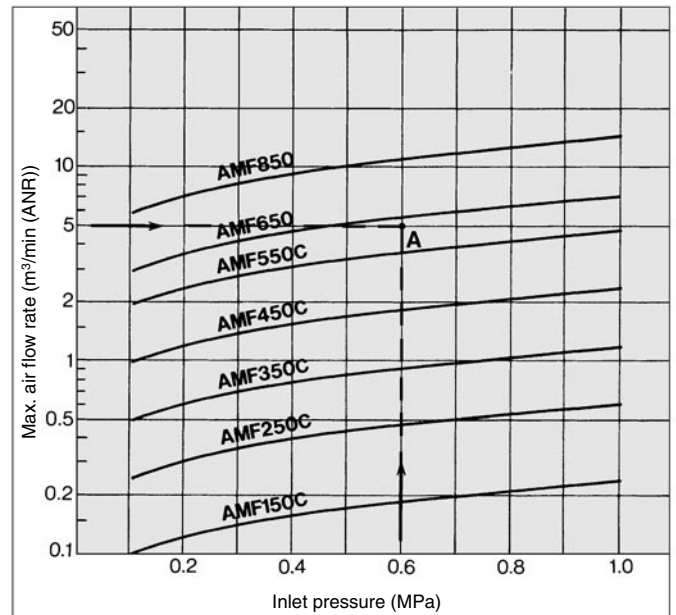

# Series AMF

## Flow Characteristics/Refer to "Model Selection" on page 54. (Element initial condition)



Note) Compressed air over max. flow line in the table below may not meet the specifications of the product. It may cause damage to the element.

**AMF150C**

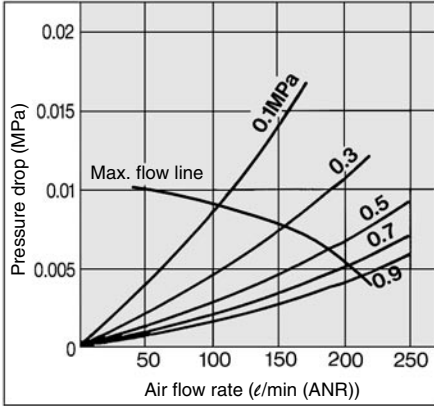

**AMF550C**

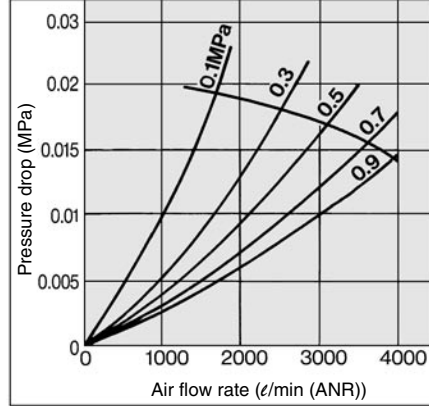

**AMF250C**

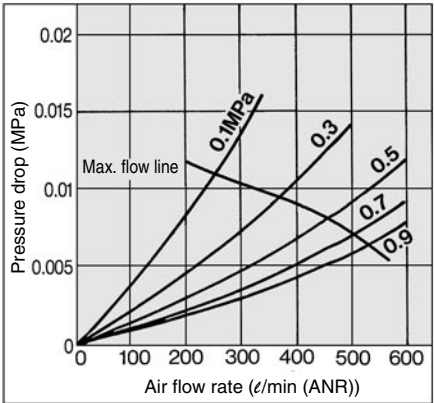

**AMF650**

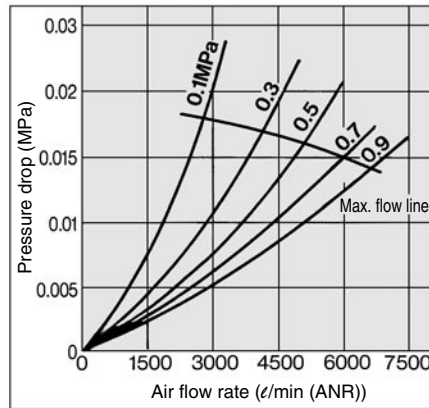

**AMF350C**

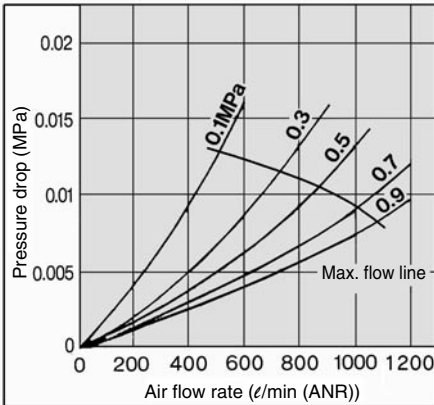

**AMF450C**

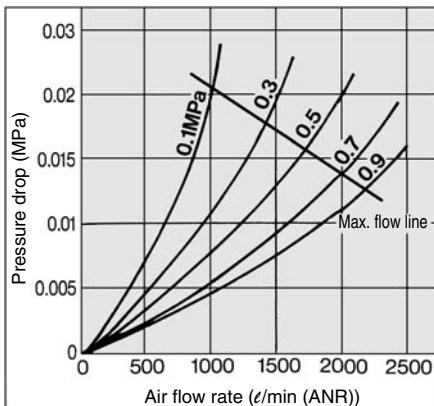

**AMF850**

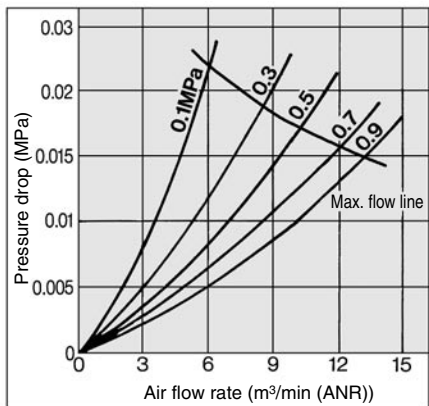



**Construction**

**AMF150C to 550C**

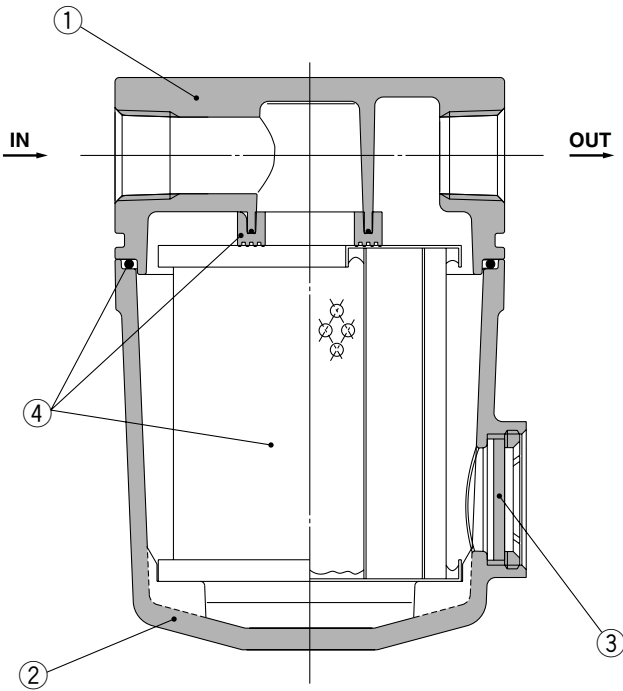

**AMF650/850**

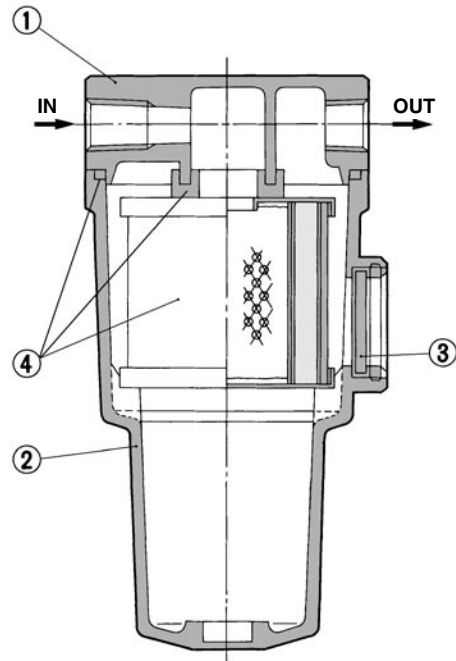

**Component Parts**

No.	Description	Material	Note
1	<b>Body</b>	Aluminum die-casted	Chrome treated
2	<b>Housing</b>	Aluminum die-casted*	Epoxy coating on inner surface
3	<b>Sight glass</b>	Tempered glass	—

\* The AMF850 is aluminum casted.



Note) Refer to "How to Order Bowl Assembly" on page 59.



Note) Sight glass is indicated in the figure for easy understanding of component parts. However, it differs from the actual construction. Refer to dimensions on pages 55 through to 57 for details.

**Replacement Parts**

No.	Description	Material	Applicable model	Model						
				AMF150C	AMF250C	AMF350C	AMF450C	AMF550C	AMF650	AMF850
4	<b>Element assembly</b>	Glass fiber, others	Except option F	AMF-EL150	AMF-EL250	AMF-EL350	AMF-EL450	AMF-EL550	AMF-EL650	AMF-EL850
			For option F	AMF-EL150-F	AMF-EL250-F	AMF-EL350-F	AMF-EL450-F	AMF-EL550-F	—	—

\* Element assembly: With gasket (1 pc.) and O-ring (1 pc.)

\* Element assemblies for Made to Order (X12, X20) are same as those for standard (see the above table).

# Series AMF

## Dimensions

### AMF150C to 350C

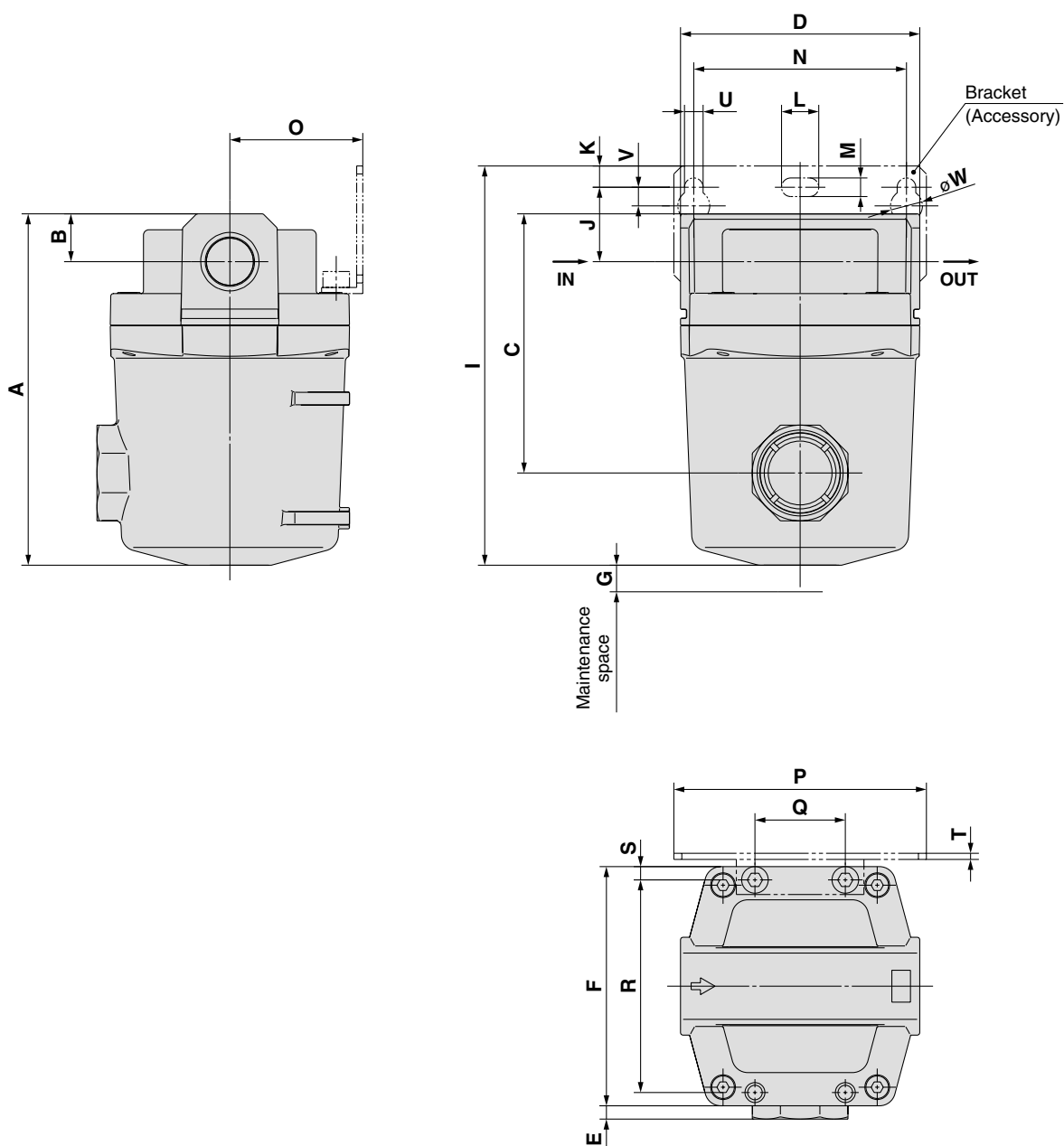

(mm)

Model	Port size	A	B	C	D	E	F	G	Bracket related dimensions														
									I	N	J	K	U	V	L	M	W	O	P	Q	R	S	T
<b>AMF150C</b>	1/8, 1/4	83	10	54	63	7.5	63	10	98.5	56	20	5	6	6	12	6	10	35	70	26	54	4.5	1.6
<b>AMF250C</b>	1/4, 3/8	103	14	73	76	5	76	10	121	66	24	8	6	6	12	6	10	40	80	28	66	5	2
<b>AMF350C</b>	3/8, 1/2	132	18	98	90	5	90	10	150	80	28	8	7	7	14	7	12	50	95	34	80	5	2.3

**Dimensions**

**AMF450C/550C**

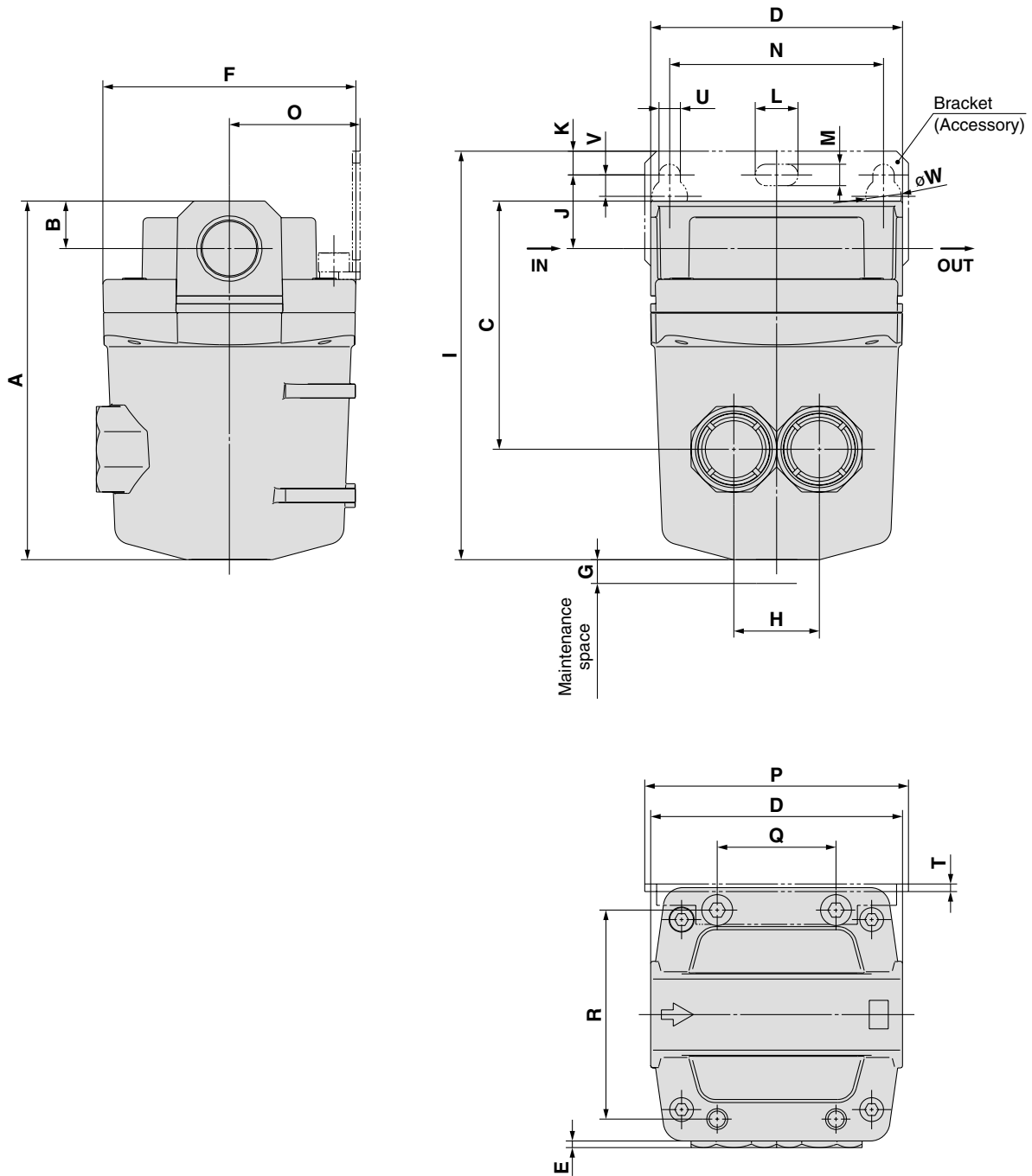

(mm)

Model	Port size	A	B	C	D	E	F	G	H	Bracket related dimensions													
										I	N	J	K	U	V	L	M	W	O	P	Q	R	T
<b>AMF450C</b>	1/2, 3/4	151	20	105	106	3	106	10	36	172	90	31	10	9	9	18	9	15	55	111	50	88	3.2
<b>AMF550C</b>	3/4, 1	187	24	130	122	3	122	15	44	206	100	33	10	9	9	18	9	15	65	126	60	102	3.2

# Series AMF

## Dimensions

### AMF650/850

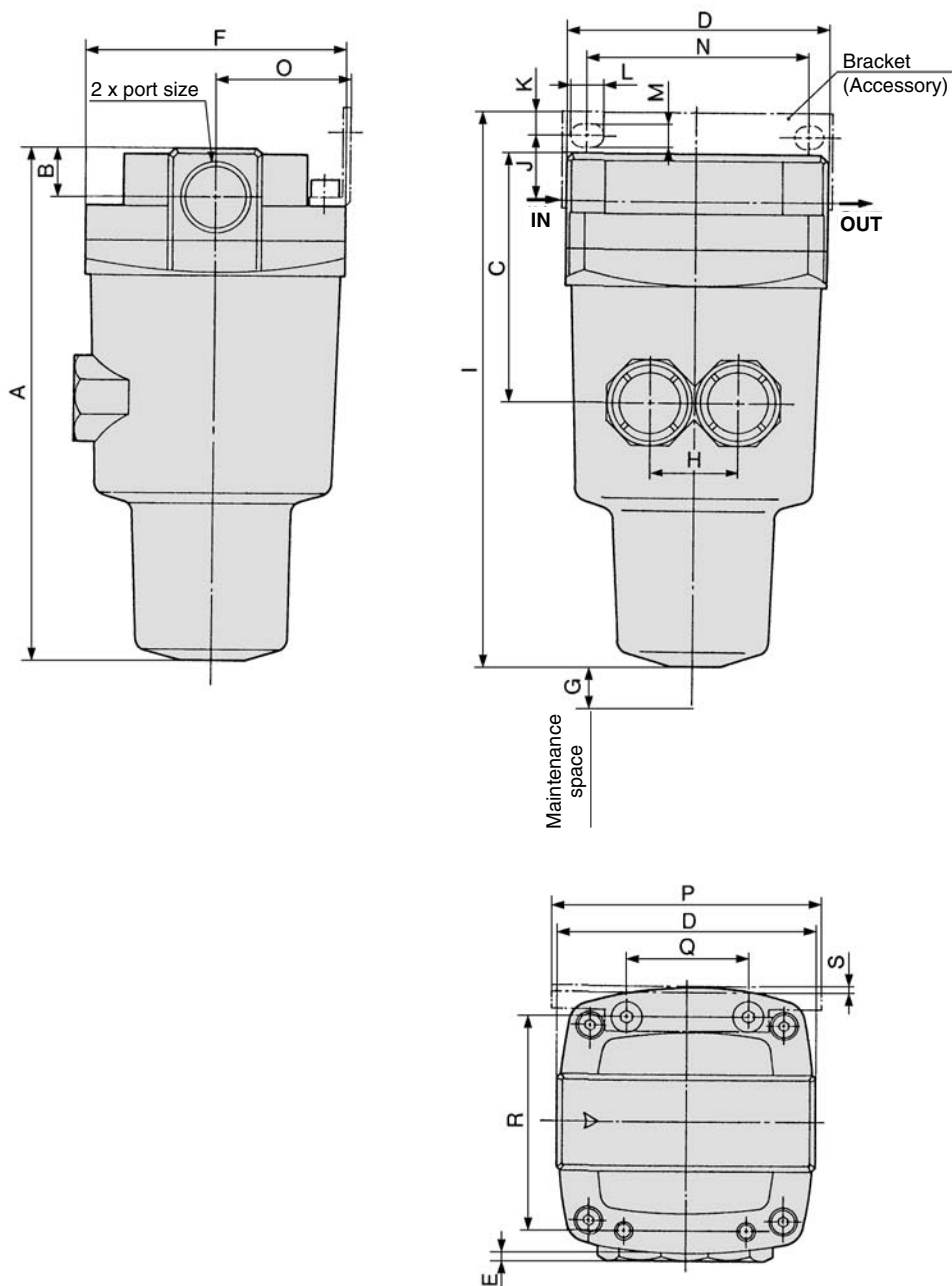

Model	Port size	A	B	C	D	E	F	G	H	Bracket related dimensions										
										I	J	K	L	M	N	O	P	Q	R	S
AMF650	1, 1 1/2	291	32	167	160	—	160	10	66	314	40	15	20	11	150	85	180	76	136	4.5
AMF850	1 1/2, 2	403	42	235	220	—	220	10	96	406	30	15	24	13	180	120	220	110	184	6

# Series AMF

## Spacer for Modular Connection

Select a spacer from those listed below when combining modular type AFF2C to 22C, AM□150C to 550C. The spacer must be ordered separately.

(Note: Spacer with bracket (Y200T to Y600T) cannot be used.)

### ⚠ Caution

#### Modular connection

Mount the attached bracket on one side when connecting 2 sets.

Mount the attached brackets on both sides when connecting 3 sets or more.

As a guideline for the number of brackets, one bracket should be mounted for every 2 products.



### Combination examples of modular applicable products

#### Arrangement example

AMH250C-□□B — 1 pc.

AME250C — 1 pc.

Y300 — 1 pc.

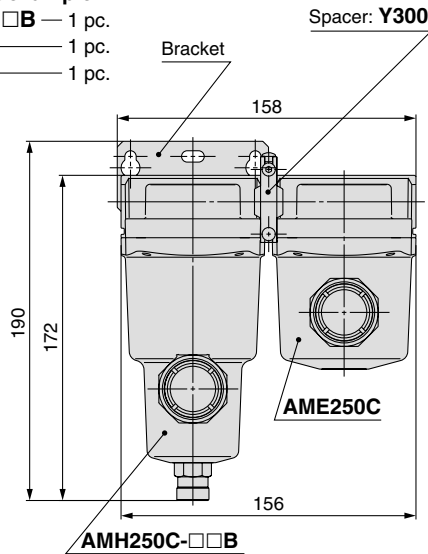

#### Arrangement example

AMH250C-□□B — 1 pc.

AME250C — 1 pc.

AMF250C-□□B — 1 pc.

Y300 — 2 pcs.

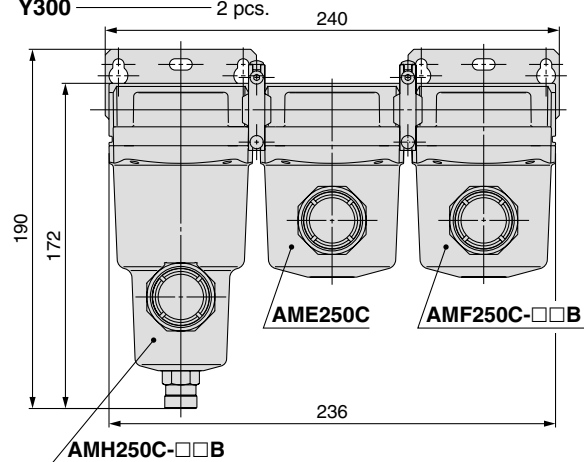

## Spacer



Model	A	B	C	D	Model
Y200	3	35.5	18.5	48	AFF2C, AM□150C
Y300	4	47	26	59	AFF4C, AM□250C
Y400	5	57	31	65	AFF8C, AM□350C
Y500	5	61	33	75	AFF11C, AM□450C
Y600	6	75.5	41	86	AFF22C, AM□550C

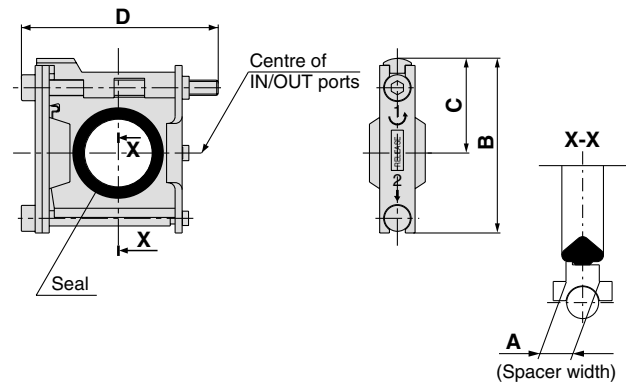

### Replacement Parts

Description	Material	Part no.				
		Y200	Y300	Y400	Y500	Y600
Seal	HNBR	Y200P-061S	Y300P-060S	Y400P-060S	Y500P-060S	Y600P-060S

## Piping Adapter

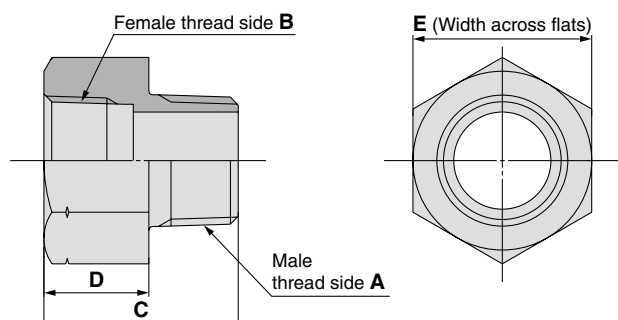

### Dimensions

Part no.	Thread type and port size		C	D	E	Material
	Male thread side A	Female thread side B				
IDF-AP609	R 3/8	NPT 3/8	30	15	22	Brass

# Bowl Assembly

# AFF-CA□/AM□-CA□

## Bowl Assembly

Bowl assembly for the AFF and AM□ series can be replaced without removing the main body from piping if the drain exhaust specification is to be changed from the drain cock type to the auto drain type or if the bowl has been damaged.

### How to Order Bowl Assembly

#### ■ AFF2C to 22C, AM, AMD, AMH, AMG150C to 550C

AM - CA □ - □ - □ - □

#### Body size

150C
250C
350C
450C
550C

#### Drain exhaust

Symbol	Description
A	With drain cock
C	With N.C. auto drain
D	With N.O. auto drain
J	With drain guide <sup>Note 1)</sup>

Note 1) Drain piping and piping for a stop valve such as a ball valve are required.

#### Option

Symbol	Description
—	—
F	Rubber material: Fluororubber
H	For medium air pressure (1.6 MPa)
V	Degreasing wash, white vaseline

#### Thread type <sup>Note 2)</sup>

Symbol	Type
—	Rc
F <sup>Note 3)</sup>	G
N	NPT

Note 2) Corresponded to the drain exhaust symbol C, D and J. Select according to the body thread type.

Note 3) Not corresponded to the drain exhaust symbol C and D. Select no symbol when the body thread symbol is F.

#### Applicable Model

Bowl assembly model	Applicable model
AM-CA150C	AFF2C, AM150C, AMD150C, AMH150C, AMG150C
AM-CA250C	AFF4C, AM250C, AMD250C, AMH250C, AMG250C
AM-CA350C	AFF8C, AM350C, AMD350C, AMH350C, AMG350C
AM-CA450C	AFF11C, AM450C, AMD450C, AMH450C, AMG450C
AM-CA550C	AFF22C, AM550C, AMD550C, AMH550C, AMG550C

#### Auto Drain Specifications/ Option Combinations

◎ : Available □ : Not available  
 △ : Plural options cannot be selected.  
 (i.e. Combinations such as C-FV, D-FHV are not possible.)

Symbol	F	H	V
A	◎	◎	◎
C	△	□	△
D	△	△	△
J	◎	◎	◎

#### ■ AFF37B/75B

AFF - CA 37B - □ - □

#### Body size

37B
75B

#### Drain exhaust

Symbol	Description
A	With drain cock <sup>Note 1)</sup>
D	With N.O. auto drain
J	With drain guide <sup>Note 2)</sup>

Note 1) Body size 75B is equipped with a ball valve (Rc3/8 female threaded). Mount a piping adapter IDF-AP609 (page 62) to the ball valve if NPT3/8 female threaded is required.

Note 2) Drain piping and piping for a stop valve such as a ball valve are required. For body size 75B, substitute with a ball valve. (symbol: A)

#### Thread type <sup>Note 3)</sup>

Symbol	Type
—	Rc
F <sup>Note 4)</sup>	G
N	NPT

Note 3) Corresponded to the drain exhaust symbol D and J. Select according to the body thread type.

Note 4) Not corresponded to the drain exhaust symbol C and D. Select no symbol when the body thread symbol is F.

## How to Order Bowl Assembly

### ■ AM, AMD, AMH, AMG Series

**AM - CA 650 -** □ □  
**AMD**  
**AMH**  
**AMG**

**Body size**

650
850

**Thread type** Note 3)

Symbol	Type
—	Rc
<b>F</b>	G
<b>N</b>	NPT

Note 3) Corresponded to the drain exhaust symbol D and J. Select according to the body thread type.

**Drain exhaust**

Symbol	Description
<b>A</b>	With drain cock <small>Note 1)</small>
<b>D</b>	With N.O. auto drain
<b>J</b>	With drain guide <small>Note 2)</small>

Note 1) Body size 850 is equipped with a ball valve (Rc3/8 female threaded). Mount a piping adapter IDF-AP609 (page 58) to the ball valve if NPT3/8 female threaded is required.

Note 2) Drain piping and piping for a stop valve such as a ball valve are required.  
 For body size 850, substitute with a ball valve. (symbol: A)

### ■ AME, AMF150C to 550C

**AME - CA** □ - **A** - □

**Body size**

150C
250C
350C
450C
550C

**Option** Note)

Symbol	Description
—	—
<b>F</b>	Rubber material: Fluororubber
<b>H</b>	For medium air pressure (1.6 MPa)
<b>V</b>	Degreasing wash, white vaseline

Note) Combination of FH is not available.

**Applicable Model**

Bowl assembly model	Applicable model
<b>AME-CA150C</b>	AME150C, AMF150C
<b>AME-CA250C</b>	AME250C, AMF250C
<b>AME-CA350C</b>	AME350C, AMF350C
<b>AME-CA450C</b>	AME450C, AMF450C
<b>AME-CA550C</b>	AME550C, AMF550C

### ■ AME, AMF650/850

**AME - CA 650 - A**  
**AMF**

**Body size**

650
850

# AFF-CA□/AM□-CA□

Dimensions: AFF, AM, AMD, AMH, AMG Series

Size: AFF2C to 22C, AFF37B, AM□150C to 550C, AM□650

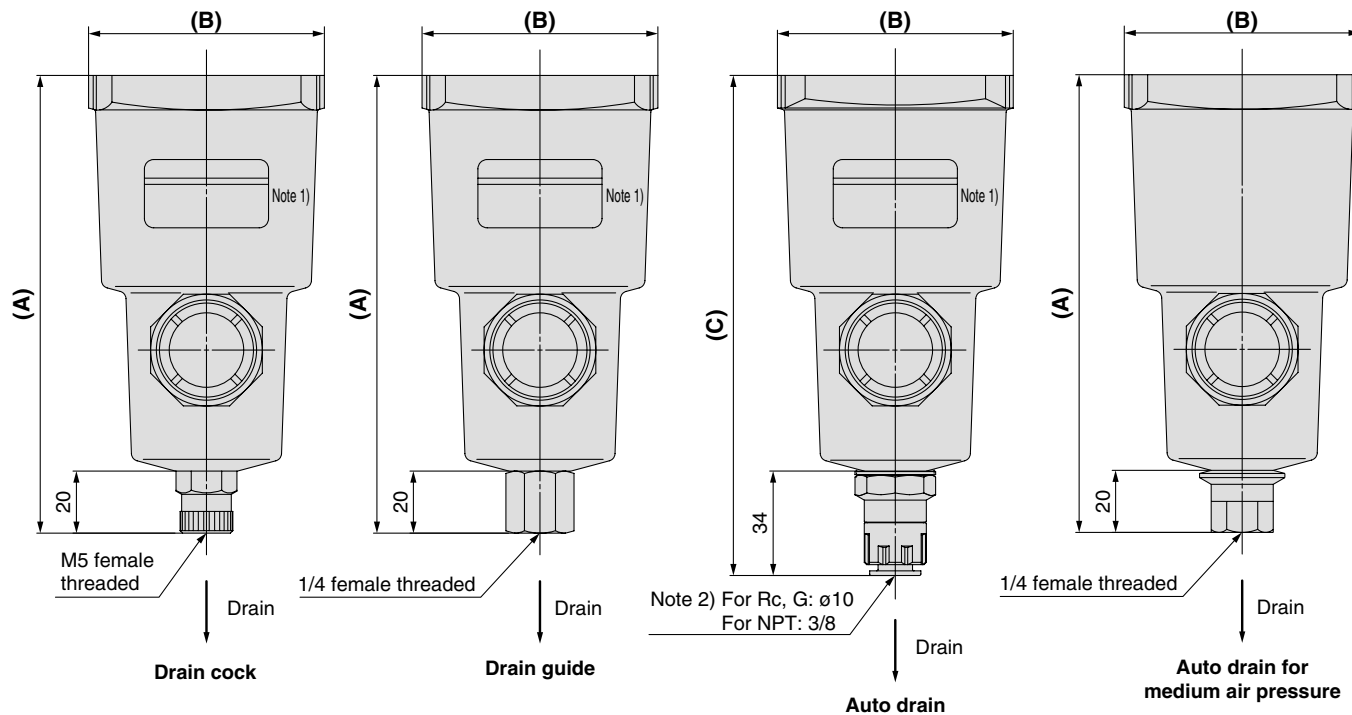

AFF series	AM, AMD, AMG, AMH series	(mm)		
Size	Size	A	B	C
2C	150C	134	63	148
4C	250C	139	76	153
8C	350C	162	90	176
11C	450C	178	106	192
22C	550C	202	122	216
37B	650	245	160	259

Note 1) Model no. labels are not affixed to the AM-CA150C to 550C.

Note 2) Select according to the body thread type.

Applicable tubing size for one-touch fitting

Rc, G: ø10

NPT: ø3/8 inch

Size: AFF75B, AM□850

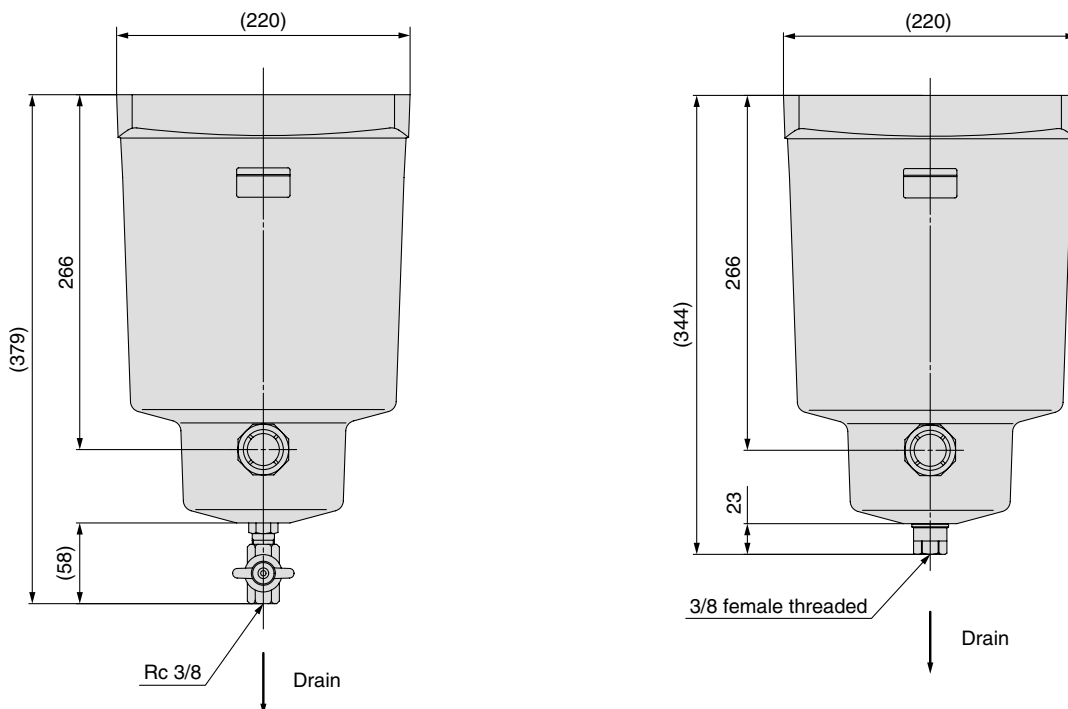



**Dimensions: AME, AMF Series**

■ AME150C to 550C, AMF150C to 550C

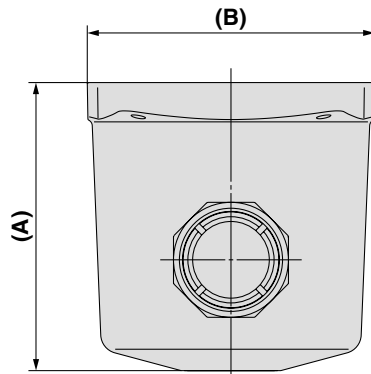

(mm)

AME, AMF series Size	A	B
<b>150</b>	60	63
<b>250</b>	70	76
<b>350</b>	90	90
<b>450</b>	104	106
<b>550</b>	130	122

■ AME650/850, AMF650/850

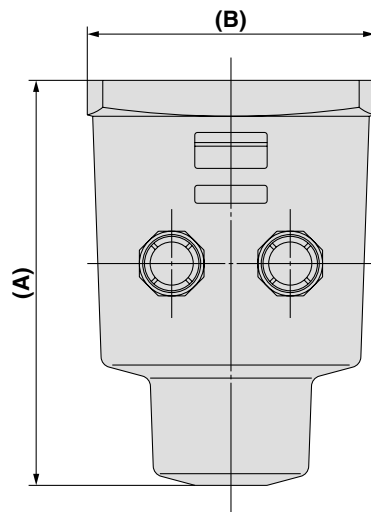

(mm)

AME, AMF series Size	A	B
<b>650</b>	225	160
<b>850</b>	319	120

# Compressed Air Cleaning Filter Series

## Made to Order/Special Specifications



Please consult with SMC for detailed specifications, size and delivery.

### Made to Order

Contents	Symbol	Applicable model							Reference page
		AFF	AM	AMD	AME	AMF	AMG	AMH	
1. With Differential Pressure Gauge (GD40-2-01)	X6	●	●	●	—	—	—	●	P.64
2. N.C., N.O. Auto Drain, Drain Piping Type	X26	●	●	●	—	—	●	●	P.65
3. White Vaseline Specifications	X12	●	●	●	●	●	●	●	

### Special Specifications

Contents	Applicable model							Reference page
	AFF	AM	AMD	AME	AMF	AMG	AMH	
Clean Series (10-Series)	●	●	●	●	●	—	●	P.66
Copper-free, Fluorine-free (20-Series)	●	●	—	—	—	●	—	

# Compressed Air Cleaning Filter Series

## Made to Order 1



Please consult with SMC for detailed specifications, size and delivery.

### 1. With Differential Pressure Gauge (GD40-2-01)

A differential pressure gauge that keeps track of the filter life is installed on the filter itself. This facilitates piping and achieves a compact design.

#### Specifications

Applicable model	<b>AFF2C to 22C, 37B, 75B</b>
------------------	-------------------------------

#### How to Order



\* Refer to "How to Order" for standard specifications.

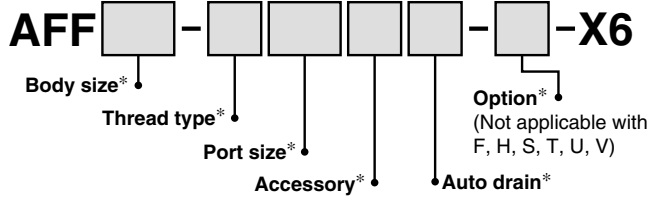

#### Specifications

Applicable model	<b>AM150C to 550C, 650, 850, AMD150C to 550C, 650, 850, AMH150C to 550C, 650, 850</b>
------------------	---

#### How to Order



\* Refer to "How to Order" for standard specifications.

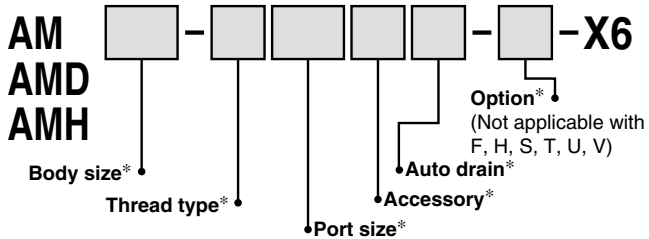

- Note)
- The AMG series is not applicable since water drops could ingress inside its differential pressure gauge, resulting in malfunction or damage to the product.
  - Cannot be mounted to the AME and AMF series. (It affects the cleanliness at the outlet.)

#### Dimensions

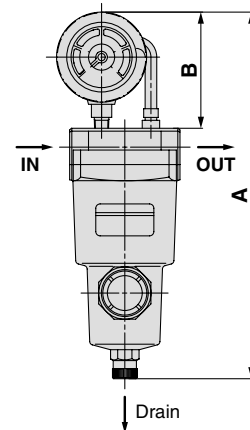

(mm)

AFF series Size	AM, AMD, AMH series Size	Port size	A	B
<b>2C</b>	<b>150C</b>	1/8, 1/4	239	80
<b>4C</b>	<b>250C</b>	1/4, 3/8	252	80
<b>8C</b>	<b>350C</b>	3/8, 1/2	284	80
<b>11C</b>	<b>450C</b>	1/2, 3/4	305	80
<b>22C</b>	<b>550C</b>	3/4, 1	339	80
<b>37B</b>	<b>650</b>	1, 1 1/2	391	80
<b>75B</b>	<b>850</b>	1 1/2, 2	541	80

# Compressed Air Cleaning Filter Series

## Made to Order 2



Please consult with SMC for detailed specifications, size and delivery.

### 2. N.C., N.O. Auto Drain, Drain Piping Type

Drain piping type (drain guide specification) to the drain exhaust from N.C. auto drain and N.O. auto drain. N.C. type is not available for the AFF37B and AM□650.

#### Specifications

Applicable model	AFF2C to 22C, 37B
------------------	-------------------

**How to Order** \* Refer to "How to Order" for standard specifications.

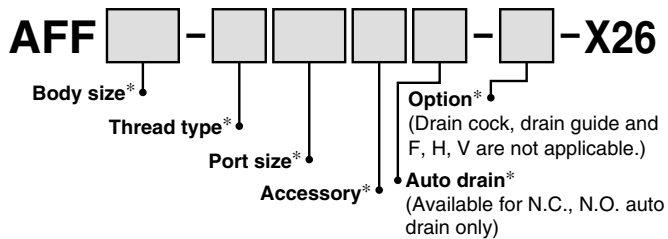

#### Specifications

Applicable model	AM□150 to 650
------------------	---------------

**How to Order** \* Refer to "How to Order" for standard specifications.

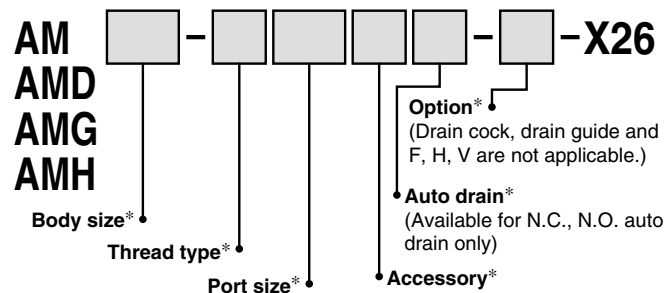

#### Dimensions

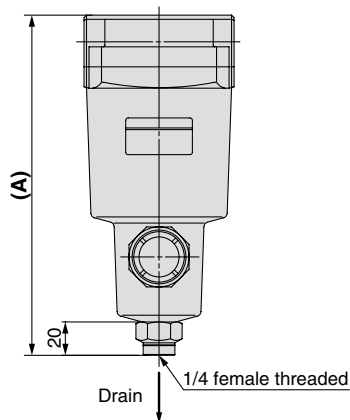

(mm)

AFF series	AM, AMD, AMG, AMH series	Port size	A
Size	Size		
2C	150C	1/8, 1/4	159
4C	250C	1/4, 3/8	172
8C	350C	3/8, 1/2	204
11C	450C	1/2, 3/4	225
22C	550C	3/4, 1	259
37B	650	1, 1 1/2	311

### 3. White Vaseline Specifications

Changed the grease for O-rings and gaskets as lubricant to white vaseline.

#### Specifications

Applicable model	AFF37B, 75B
------------------	-------------

**How to Order** \* Refer to "How to Order" for standard specifications.

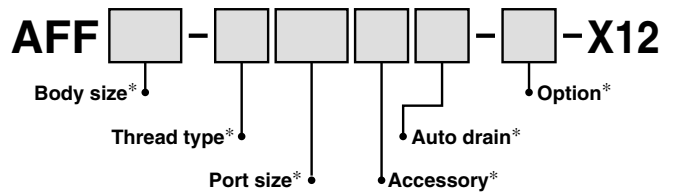

#### Specifications

Applicable model	AM650, 850, AMD650, 850, AME650, 850, AMF650, 850, AMG650, 850, AMH650, 850
------------------	---

**How to Order** \* Refer to "How to Order" for standard specifications.

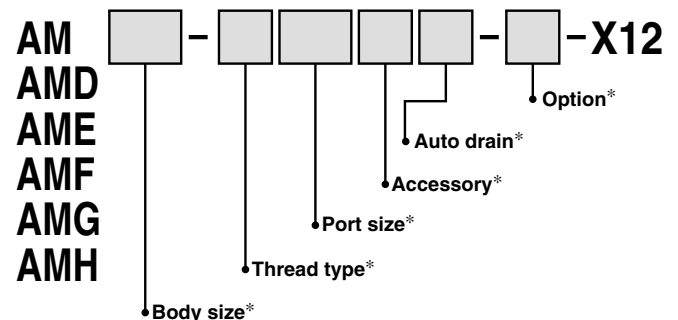

# Compressed Air Cleaning Filter Series

## Special Specifications

Please consult with SMC for detailed specifications, size and delivery.

### Clean Series (10-Series)

Clean Series products are used in cleaner environments such as in clean rooms as compared to a general factory environment. For further details, refer to the Clean Series catalogue.

#### Specifications

Applicable model	AFF2C to 22C, 37B, 75B
------------------	------------------------

#### How to Order

\* Refer to "How to Order" for standard specifications.

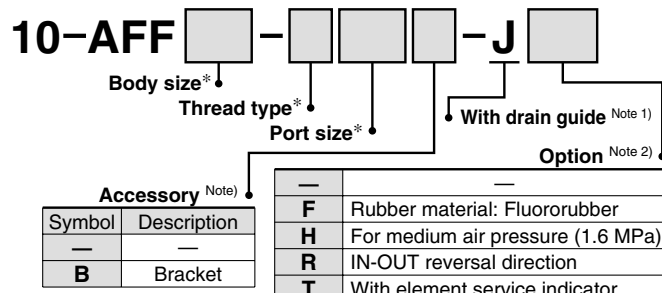

Note 1) "10-" is not applicable to standard product (with drain cock) and with auto drain.

Note 2) Combination of FT is not available.  
F and H are only applicable to the AFF2C to 22C.

#### Specifications

Applicable model	AM150C to 550C, 650, 850, AMD150C to 550C, 650, 850, AMH150C to 550C, 650, 850
------------------	--

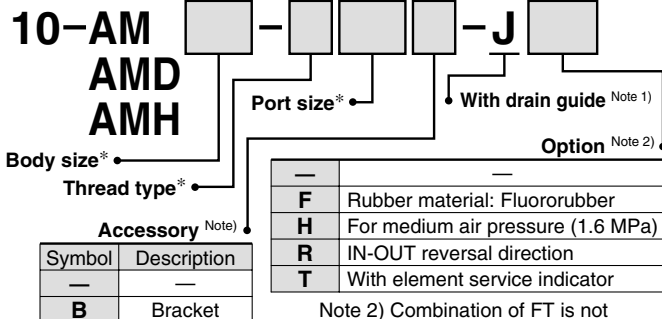

Note 1) "10-" is not applicable to standard product (with drain cock) and with auto drain.

Note 2) Combination of FT is not available.  
F and H are only applicable to the AM□150C to 550C.

#### Specifications

Applicable model	AME150C to 550C, 650, 850, AMF150C to 550C, 650, 850
------------------	--

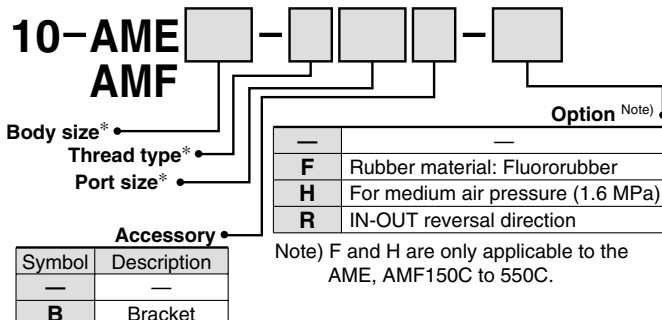

Note) F and H are only applicable to the AME, AMF150C to 550C.

### Copper-free, Fluorine-free (20-Series)

To eliminate effects on colour CRTs, etc. by copper ion or fluorine resin, copper materials are electroless-nickel plated or changed to copper-free materials to prevent the generation of copper ions. (It is not applicable to the AMD, AME, AMF and AMH series because those include fluorine resin in the filter material of the element.)

#### Specifications

Applicable model	AFF2C to 22C, 37B
------------------	-------------------

#### How to Order

\* Refer to "How to Order" for standard specifications.

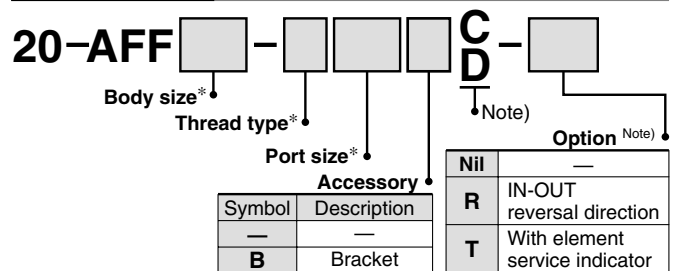

Note) "20-" is only applicable with N.C. auto drain (C) or N.O. auto drain (D). Drain cock and drain guide are copper-free, fluorine-free as standard.

#### Specifications

Applicable model	AFF75B
------------------	--------

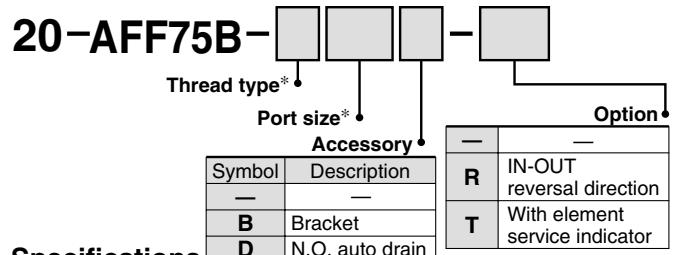

#### Specifications

Applicable model	AM150C to 550C, 650, AMG150C to 550C, 650
------------------	---

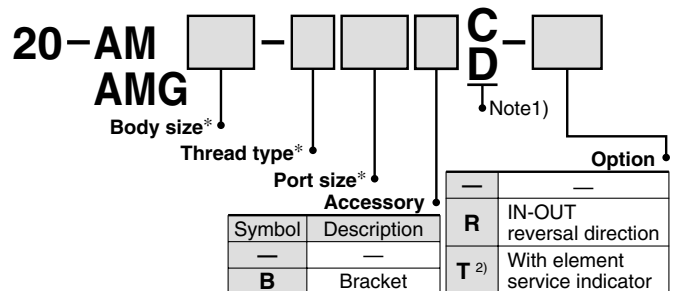

Note1) "20-" is only applicable with N.C. auto drain (C) or N.O. auto drain (D). Drain cock and drain guide are copper-free, fluorine-free as standard.

Note2) AMG is not available.

#### Specifications

Applicable model	AM850, AMG850
------------------	---------------

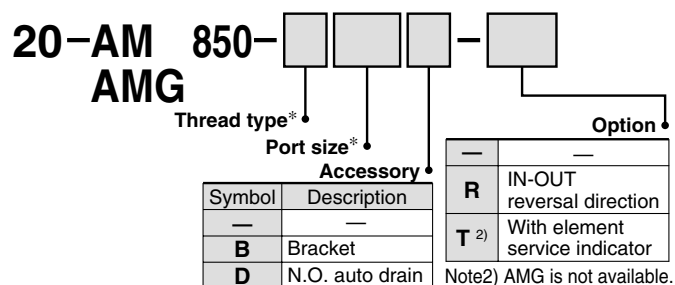

Note2) AMG is not available.

# Related Products: Auto Drain Valve

# Series AD402/600

Drain is automatically discharged in a reliable manner, without requiring human operators.

Highly resistant to dust and corrosion, operates reliably, and a bowl guard is provided as standard equipment.



AD402



AD600

JIS Symbol



## Model/Specifications

Model	AD402	AD600
Proof pressure	1.5 MPa	1.5 MPa
Max. operating pressure	1.0 MPa	1.0 MPa
Operating pressure range <sup>Note)</sup>	0.1 to 1.0 MPa	0.3 to 1.0 MPa
Ambient and fluid temperature	-5 to 60°C (No freezing)	-5 to 60°C (No freezing)
Port size	1/4, 3/8, 1/2	3/4, 1
Drain port size	3/8	3/4, 1
Mass (g)	620	2100

Note) 400 ℓ/min (ANR) or more

## ⚠ Specific Product Precautions

Be sure to read this before handling.

Refer to back page 1 for Safety Instructions, "Precautions for Handling Pneumatic Devices" (M-03-E3A) for Common Precautions.

### Selection

#### ⚠ Warning

Use the auto drain under the following operating conditions in order to prevent malfunction.

- 1) Operate the compressor above 3.7 kw {400 ℓ/min (ANR)}.
- 2) Use the AD402 at an operating pressure above 0.1 MPa and AD600 above 0.3 MPa.

### Piping

#### ⚠ Warning

Piping should be done under the following conditions in order to prevent malfunction.

For drain piping, use a pipe whose I.D. is not less than ø10 and length not more than 5 m. Avoid riser piping.

## How to Order

AD402 - [ ] 03 - [ ]

#### Thread type

—	Rc
N	NPT
F	G

#### Option

—	—
2	Metal bowl

#### Port size

Symbol	IN	OUT
02	1/4	3/8
03	3/8	3/8
04	1/2	3/8

AD600 - [ ] 06

#### Thread type

—	Rc
N	NPT
F	G

#### Port size

Symbol	IN	OUT
06	3/4	3/4
10	1	1

## Construction/Dimensions

### AD402

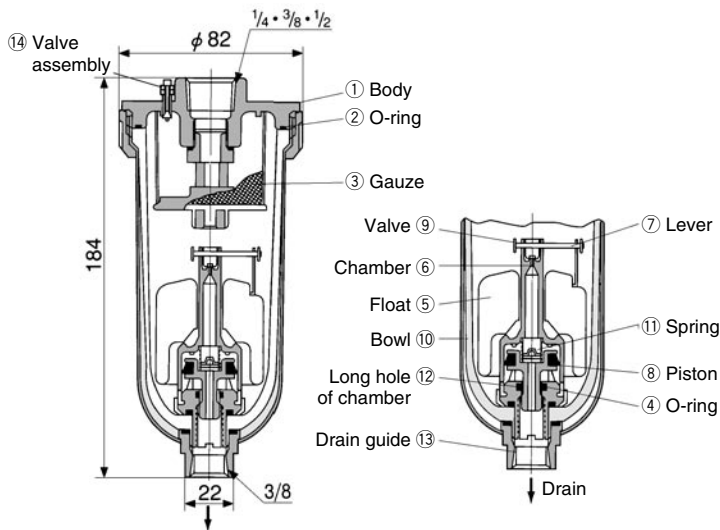

### AD600

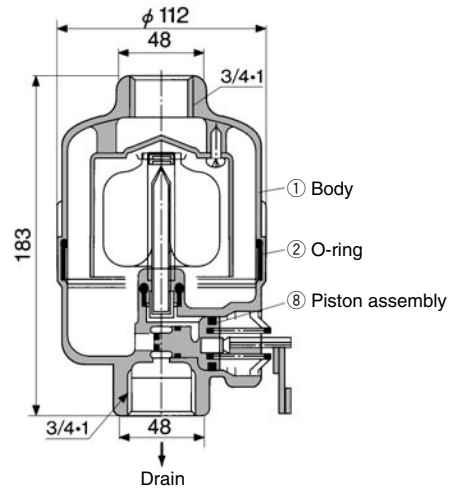

### Working Principle (AD402)

- When no pressure is applied inside the bowl ⑩, float ⑤ descends of its own weight and valve ⑨ closes the chamber ⑥ hole. Piston ⑧ is pushed down by spring ⑪, and drain passes through the chamber's long hole ⑫ to enter the housing and is discharged.
- When pressure is applied inside the bowl:  
When pressure is 0.1 MPa or more, it overcomes the force of spring ⑪, allowing the piston ⑧ to ascend, and comes in contact with O-ring ④. Thus, the inside of the bowl ⑩ is isolated from the outside.
- When drain has accumulated:  
Float ⑤ ascends due to flotation and opens the chamber hole ⑥, allowing the pressure to enter the chamber ⑥. Piston ⑧ descends due to internal pressure and the force of spring ⑪, and the accumulated drain is discharged through drain guide ⑬.

### Component Parts

No.	Description	Material
1	Body	Aluminum die-casted

### Replacement Parts

No.	Description	Material	Model	
			AD402	AD600
2	O-ring	NBR	113136	JIS B2401G-100
3	Gauze	Stainless steel	20062	—
Note 1)	Internal assembly	—	AD34PA	—
8	Piston assembly	—	—	20025A

Note 1) Internal assembly: Assembly for parts ④ to ⑫ except ⑩.

Note 2) Part no. for bowl assembly: AD34

Note 3) Part no. for bowl ⑩: 201016

# Related Products: Heavy Duty Auto Drain Series **ADH4000**

## Easy maintenance

Can maintain without removing the existing piping.

## No need for electric power and no waste of air.

Float type auto drain allows automatic drain discharge without electric power.

## Mounting example

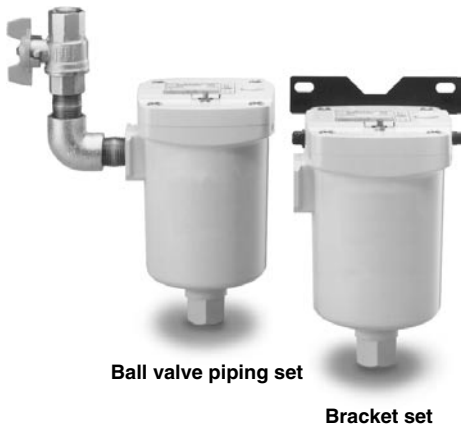
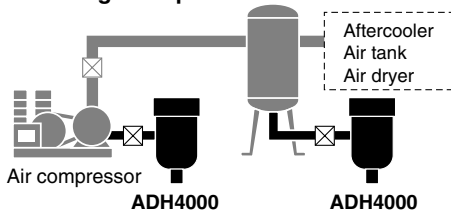

JIS Symbol

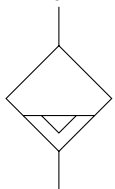

## Specifications

Auto drain type	Float type
Auto drain valve type	N.O. (Normally open: Open in the case of pressure loss)
Proof pressure	2.5 MPa
Max. operating pressure	1.6 MPa
Operating pressure range <sup>Note)</sup>	0.05 to 1.6 MPa
Fluid	Compressed air
Ambient and fluid temperature	5 to 60°C (With no condensation) <Corrosive gas, flammable gas and organic solvents are not allowed.>
Max. drain discharge	400 cc/min (Pressure 0.7 MPa, in the case of water)
Mass	1.2 kg (With bracket: 1.3 kg)
Paint colour	White



Note) Use for an air compressor with flow more than 50 l/min (ANR).

## Accessory (Option)

Description	Part no.	Contents
Bracket set	BM58	Bracket ..... 1 pc. M6 x 10 l (Hexagon socket head cap screw) ... 2 pcs.
Ball valve piping set	ADH-C400	Ball valve/Rc 1/2 ..... 1 pc. Barrel nipple/R 1/2 ..... 2 pcs. Elbow/Rc 1/2 ..... 1 pc.



Note) Accessory (Option) is included, but not assembled.

## How to Order

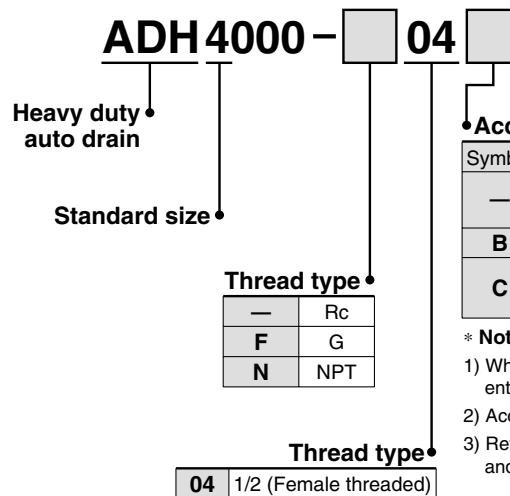

### • Accessory (Option)\*

Symbol	Contents	Note
—	None (Standard)	—
<b>B</b>	Bracket set	—
<b>C</b>	Ball valve piping set	Not available for G/NPT threads.

### \* Notes

- 1) When more than one option is desired, enter in alphabetical order.
- 2) Accessory is not assembled.
- 3) Refer to each drawing of dimensions and mounting methods for details.



## Construction

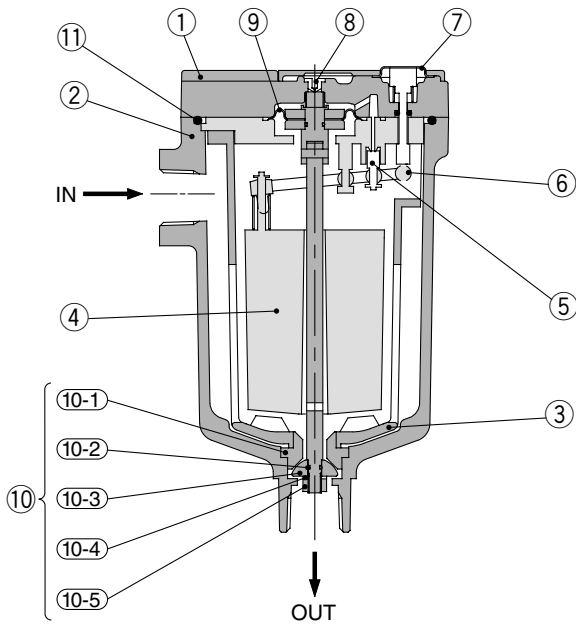

### Component Parts

No.	Description	Material	Note
1	Body	Aluminum alloy	Baking finish
2	Housing	Aluminum alloy	Baking finish
3	Drain guard	Aluminum alloy	Baking finish
4	Float	Foam rubber	
5	Pilot valve	Stainless steel + Rubber	
6	Lever	Resin	
7	Flushing button	Brass	
8	Orifice		
9	Diaphragm	Rubber	

### Replacement Parts

No.	Description	Part no.	Note
10	Repair kit for main valve	ADH-D400	Kit includes parts from (10-1) to (10-5)
11	O-ring	G85(B)	Material: NBR

Note) When changing parts, follow the operating manual.  
Do not disassemble other parts.

## ⚠ Specific Product Precautions

Be sure to read this before handling. Refer to back pages 1 and 2 for Safety Instructions, "Precautions for Handling Pneumatic Devices" (M-03-E3A) for Common Precautions.

### Design

#### ⚠ Caution

- Use this product in an area where the air pressure does not exceed 1.6 MPa.  
If exceeding 1.6 MPa, it could lead to an accident or malfunction.
- An air pressure of 0.05 MPa and an air compressor's discharge flow rates higher than 50 ℓ/min (ANR) are required.  
Below these values, the air will be exhausted continuously from the drain exhaust port.
- Keep the compressed air and the ambient temperature of the location where this product is installed within the range of 5 to 60°C. Exceeding this range could lead to a failure or malfunction.
- Avoid using this product in an area where corrosive gases, flammable gases or organic solvents are contained in the compressed air or in the surrounding air.

### Selection

#### ⚠ Caution

- The maximum dischargeable drainage rate is 400 cc/min.  
If using this product in excess of this value, there could be causing the drain to flow over to the outlet side.

### Piping

#### ⚠ Caution

- Use piping of 1/2<sup>B</sup> or larger for drain inlet and avoid riser piping.
- For drain piping, use a pipe whose I.D. is not less than 8 mm and length not more than 10 m. Do not make any upward angles in drain line. Be sure to secure exhaust port piping since drain is under pressure.

### Mounting

#### ⚠ Caution

- Install with "out port" down in a vertical position.  
Inclination from the vertical line should be less than 5°.
- Install with at least 200 mm of free space above the unit to allow for maintenance.
- To place this product near the air compressor, install in such a way that the vibrations will not be transmitted.
- Install a valve to drain inlet so that maintenance is possible.  
Use a ball valve with a bore size of more than 15 mm. (Ball valve piping set is available as an accessory (option).)

### Mounting

#### ⚠ Caution

- When not draining sufficiently, open the bleed valve so that drain could run through easily.

### Maintenance

#### ⚠ Caution

- Check drain condition periodically (more than once a day).  
Also, push the flushing button to open the exhaust valve.
- Pilot air is exhausted from the exhaust port indicated in "Dimensions". **Do not cover this exhaust port.** Clean the exhaust port so that port is not blocked by dust, etc.
- When solid foreign objects exceeding 1 mm come in, the main valve may become blocked. After recovering the internal pressure of this product to 0 MPa (atmospheric pressure), remove the hexagon socket head cap screw (M6) from the body part and wash inside with water to remove foreign solid objects blocking the main valve.
- When using this product, drain may not easily enter the product. In such a case, adjust the open angle of its bleed valve to lower the pressure a bit inside the bowl so that drain could run through easily.

# Series ADH4000

## Dimensions

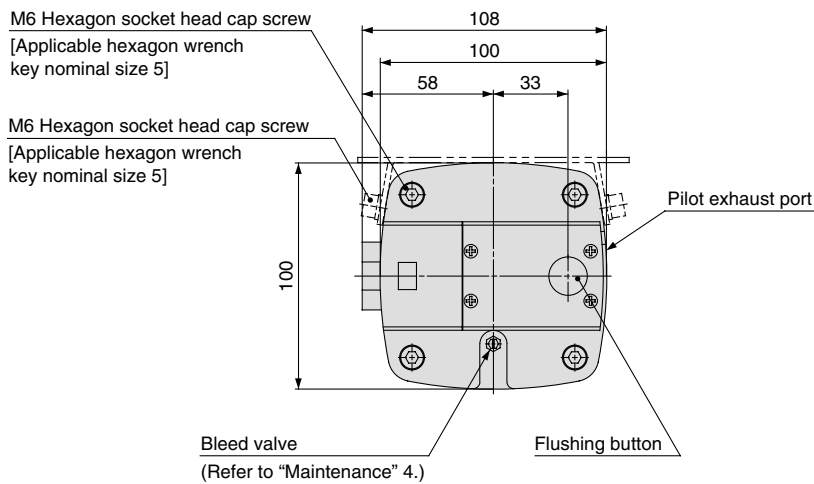
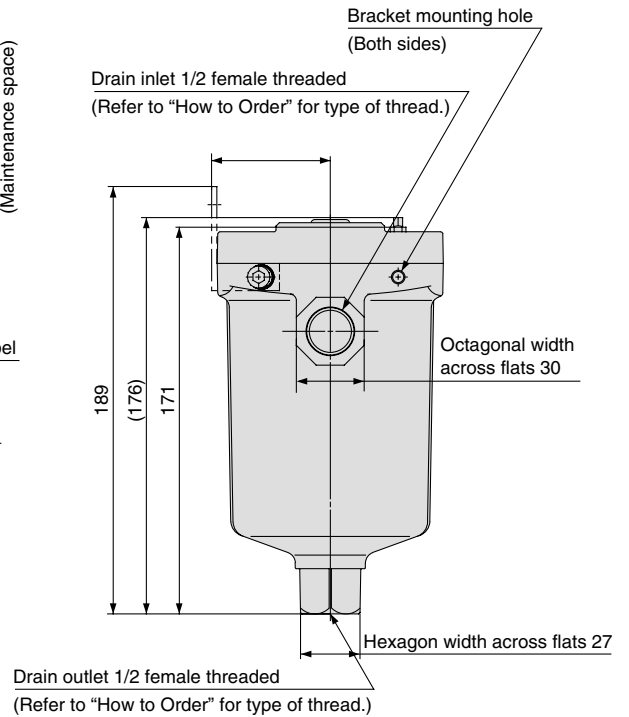
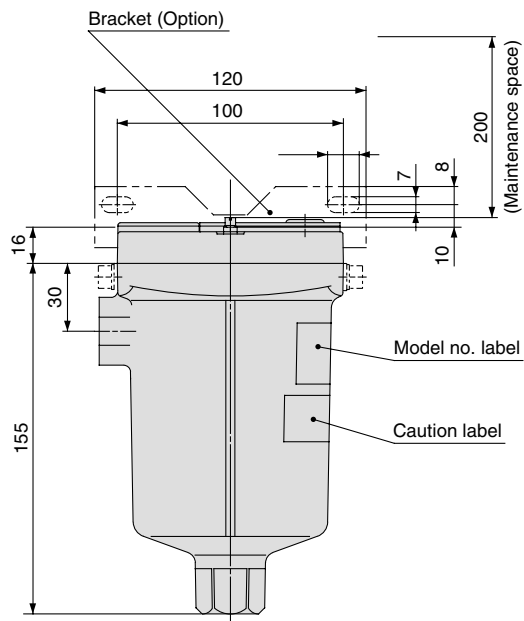

### Option: Reference Figure of Assembly

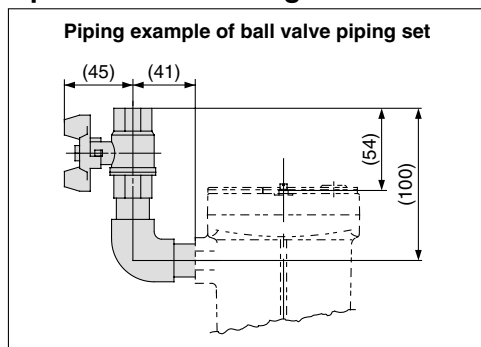

# Related Products: Differential Pressure Gauge Series *GD40-2-01*

The pressure differential at the inlet and the outlet of compressed air equipment can be viewed at a glance on the differential pressure gauge. It is ideal for the maintenance control of filters.

Compact and lightweight  
Can be installed easily by merely providing a bypass circuit.  
Provided with a protective cover to prevent hazards.



JIS Symbol



## Piping Example

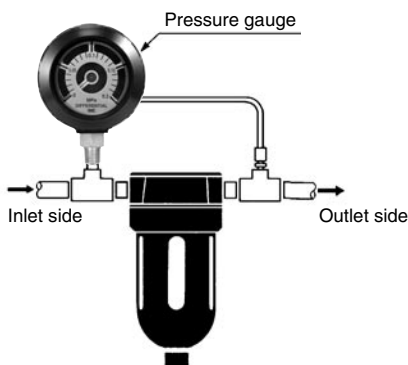

## Model/Specifications

Model	GD40-2-01
Fluid	Compressed air
Max. operating pressure	1 MPa
Proof pressure	1.5 MPa
Ambient and fluid temperature	5 to 60°C
Port size Rc	1/8
Scale range	0 to 0.2 MPa
Accuracy	±0.006 MPa
Dial size	ø40
Mass (g)	300

## Main Parts Material

Case	Zinc die-casted
Internal part	Brass, Phosphor bronze
Window	Polyester
Scale plate	Stainless steel

## Accessory

Nylon tube	T0425 (0.5 m)
Male connector	H04-01 (1 pc.)
Male elbow	DL04-01 (1 pc.)

## ⚠ Specific Product Precautions

Be sure to read this before handling.

Refer to back pages 1 and 2 for Safety Instructions, "Precautions for Handling Pneumatic Devices" (M-03-E3A) for Common Precautions.

### Design

#### ⚠ Caution

1. This product cannot be used in a location where pulsations could occur frequently.

### Mounting

#### ⚠ Caution

1. Mounting
  - 1) The HIGH and LOW marks on the back of the differential pressure gauge indicate the high pressure and low pressure sides respectively. Connect the HIGH side to the inlet side of the filter or other devices and the LOW side to their outlet side. Do not use a stop valve to prevent damage to the differential pressure gauge if the valve is inadvertently left open or closed.
  - 2) Install the differential pressure gauge vertically.
  - 3) The piping of the differential pressure gauge must be connected securely because it will break if it becomes detached.

## Dimensions

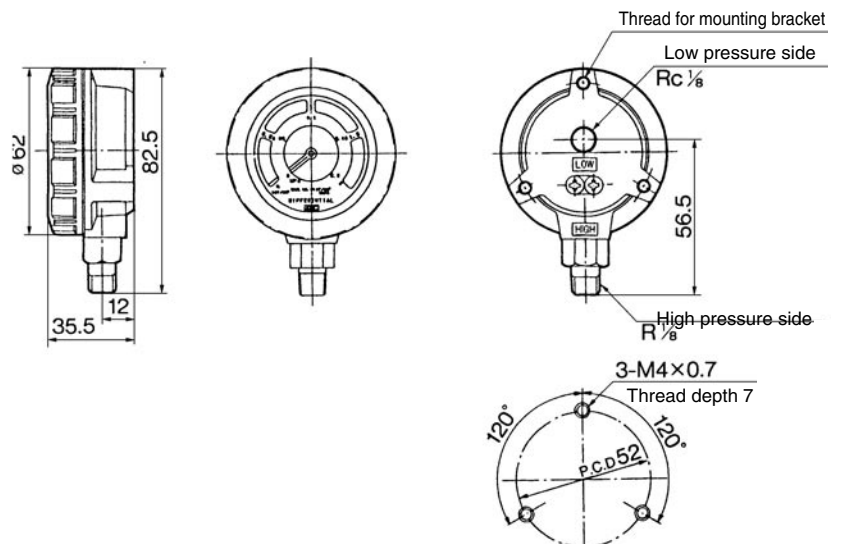





# Safety Instructions

These safety instructions are intended to prevent hazardous situations and/or equipment damage. These instructions indicate the level of potential hazard with the labels of “**Caution,**” “**Warning**” or “**Danger.**” They are all important notes for safety and must be followed in addition to International Standards (ISO/IEC)<sup>Note 1)</sup> and other safety regulations.

Note 1) ISO 4414: Pneumatic fluid power – General rules relating to systems.  
ISO 4413: Hydraulic fluid power – General rules relating to systems.  
IEC 60204-1: Safety of machinery – Electrical equipment of machines. (Part 1: General requirements)  
ISO 10218: Manipulating industrial robots -Safety.  
etc.

 **Caution:** Operator error could result in injury or equipment damage.

 **Warning:** Operator error could result in serious injury or loss of life.

 **Danger :** In extreme conditions, there is a possibility of serious injury or loss of life.

## Warning

### **1. The compatibility of the product is the responsibility of the person who designs the equipment or decides its specifications.**

Since the product specified here is used under various operating conditions, its compatibility with specific equipment must be decided by the person who designs the equipment or decides its specifications based on necessary analysis and test results. The expected performance and safety assurance of the equipment will be the responsibility of the person who has determined its compatibility with the product. This person should also continuously review all specifications of the product referring to its latest catalogue information, with a view to giving due consideration to any possibility of equipment failure when configuring the equipment.

### **2. Only personnel with appropriate training should operate machinery and equipment.**

The product specified here may become unsafe if handled incorrectly. The assembly, operation and maintenance of machines or equipment including our products must be performed by an operator who is appropriately trained and experienced.

### **3. Do not service or attempt to remove product and machinery/equipment until safety is confirmed.**

1. The inspection and maintenance of machinery/equipment should only be performed after measures to prevent falling or runaway of the driven objects have been confirmed.

2. When the product is to be removed, confirm that the safety measures as mentioned above are implemented and the power from any appropriate source is cut, and read and understand the specific product precautions of all relevant products carefully.

3. Before machinery/equipment is restarted, take measures to prevent unexpected operation and malfunction.

### **4. Contact SMC beforehand and take special consideration of safety measures if the product is to be used in any of the following conditions.**

1. Conditions and environments outside of the given specifications, or use outdoors or in a place exposed to direct sunlight.

2. Installation on equipment in conjunction with atomic energy, railways, air navigation, space, shipping, vehicles, military, medical treatment, combustion and recreation, or equipment in contact with food and beverages, emergency stop circuits, clutch and brake circuits in press applications, safety equipment or other applications unsuitable for the standard specifications described in the product catalogue.

3. An application which could have negative effects on people, property, or animals requiring special safety analysis.

4. Use in an interlock circuit, which requires the provision of double interlock for possible failure by using a mechanical protective function, and periodical checks to confirm proper operation.



# Safety Instructions

## Caution

**The product is provided for use in manufacturing industries.**

The product herein described is basically provided for peaceful use in manufacturing industries.

If considering using the product in other industries, consult SMC beforehand and exchange specifications or a contract if necessary. If anything is unclear, contact your nearest sales branch.

## Limited Warranty and Disclaimer/Compliance Requirements

The product used is subject to the following “Limited Warranty and Disclaimer” and “Compliance Requirements”. Read and accept them before using the product.

### Limited Warranty and Disclaimer

1. **The warranty period of the product is 1 year in service or 1.5 years after the product is delivered.**<sup>Note 2)</sup>

The product may also have specified durability, running distance or replacement parts. Please consult your nearest sales branch.

2. **For any failure or damage reported within the warranty period, which is clearly SMC's responsibility, a replacement product or necessary parts will be provided.**

This limited warranty applies only to SMC product independently, and not to any other damage incurred due to failure of the product.

3. **Before using SMC products, please read and understand the warranty terms and disclaimers noted in the specified catalogue for the particular products.**

**Note 2) Vacuum pads are excluded from this 1 year warranty.**

A vacuum pad is a consumable part, so it is warranted for a year after it is delivered.

Also, even within the warranty period, the wear of a product due to the use of the vacuum pad or failure due to the deterioration of rubber material are not covered by the limited warranty.

### Compliance Requirements

**When the product is exported, strictly follow the laws required by the Ministry of Economy, Trade and Industry (Foreign Exchange and Foreign Trade Control Law).**



## Series AM□/AFF

# Specific Product Precautions 1

Be sure to read this before handling. Refer to back pages 1 and 2 for Safety Instructions, and "Precautions for Handling Pneumatic Devices" (M-03-E3A) for Common Precautions.

### Design

#### ⚠ Caution

1. Design the layout so that the mist separator should be installed in an area that is less susceptible to pulsations.

The element could be damaged if a difference between the inlet pressure and the outlet pressure exceeds 0.1 MPa.

2. Be careful of dust generation by the pneumatic equipment mounted on the outlet side.

When installing pneumatic equipment on the outlet side of the AM□ series, dust particles may come off from outlet equipment, which will lower the cleanliness of compressed air. Consider this impact upon the cleanliness of compressed air when installing pneumatic equipment on the outlet side.

3. About when to use N.C. auto drain and N.O. auto drain.

When using the AFF2C to 22C, 37B, 75B, AM□150C to 550C, 650, 850 with normally open (N.O.) auto drain, air may ceaselessly blow out of the drain discharge area when an air compressor with a small air discharge volume is used since the valve does not close unless the air pressure is 0.1 MPa or higher. Therefore, when using a compressor for 3.7 kW or less, make sure to use the normally closed (N.C.) auto drain. The minimum operating pressure is 0.15 MPa even with N.C. auto drain.

4. Use a tubing with proper size and length for drain piping of auto drain.

When using the AFF2C to 22C, 37B, AM□150C to 550C, 650 with auto drain:

Normally closed (N.C.)	} Use tubing O.D. 10 mm and keep the whole length within 5 m.
Normally open (N.O.)	

When using the AFF75B and AM□850 with auto drain:

Normally open (N.O.): Use tubing I.D. 9 mm or more and keep the whole length within 2.8 m.

5. Provide a design that prevents back pressure and back flow.

Back pressure or back flow may damage an element.

#### ⚠ Warning

1. Hold the female thread side and tighten to the recommended torque when screwing in the piping material.

Insufficient tightening torque may cause loosening or defective sealing. Over-tightening torque may damage the thread etc. If it is tightened without holding the female thread side, excessive force will be directly applied to the piping bracket resulting in a product failure.

#### Recommended Torque

Unit: N·m

Connection thread	1/8	1/4	3/8	1/2	3/4	1	1 1/2	2
Torque	1.5 to 2	7 to 9	12 to 14	28 to 30	28 to 30	36 to 38	48 to 50	48 to 50

\* After tightening manually, tighten additionally by about 1/6 turn with a tightening tool.

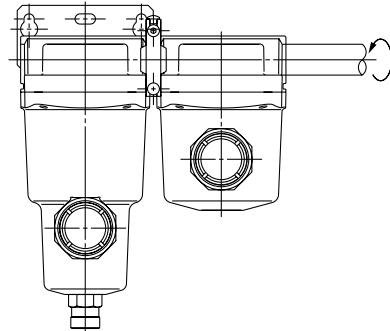

2. Do not apply torsional moment or bending moment (except the product's own weight) to the bracket. It may damage the bracket. Support external piping separately.

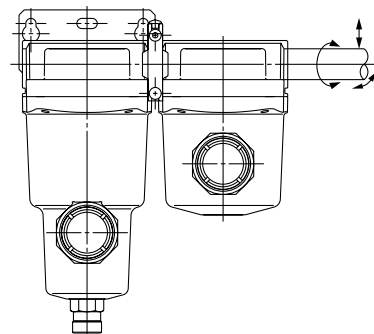

3. Inflexible piping such as steel piping tends to be affected by spread of excessive moment load or vibration from the piping side. Lay flexible tubing between the steel pipe and the product to prevent such effects.



# Series AM□/AFF Specific Product Precautions 2

Be sure to read this before handling. Refer to back pages 1 and 2 for Safety Instructions, and “Precautions for Handling Pneumatic Devices” (M-03-E3A) for Common Precautions.

## Selection

### ⚠ Caution

#### 1. About the system composition of purifying compressed air

Compressed air generally contains particulate contaminants as listed below, though there are some variations due to the compressor type and specifications. Determine the system configuration according to the desired cleanliness of compressed air and application, while referring to the “Air Preparation Equipment Selection Guide” for the AM□ series (Best Pneumatics).

##### [Particulate contaminants in compressed air]

- Water (drainage)
- Dust sucked from ambient air
- Degenerated oil from compressor
- Solid foreign matter such as rust inside piping and oil

#### 2. Select according to the maximum flow consumption.

When compressed air is used for air blow, etc., find the maximum air consumption before selecting the size of the AM□ series. (If compressed air exceeding the maximum flow rate is supplied, it can result in decline of the cleanliness of compressed air or element damage.)

## Mounting

### ⚠ Caution

#### 1. About the mounting orientation of the products

Make sure to install this product on horizontal piping. If it is installed diagonally, laterally, or upside down, the drain separated by the element will splash to the outlet side.

## Piping

### ⚠ Caution

#### 1. Connect it with IN and OUT ports in proper location. It does not work with the connection reversed.

In the case of the AFF2C to 22C, 37B, 75B, AM□150C to 550C, 650, 850

Verify the direction of the flow of the compressed air and the “⇨” or “▷” mark that indicates the inlet of the product before connecting. It cannot be used if connected in the opposite direction.

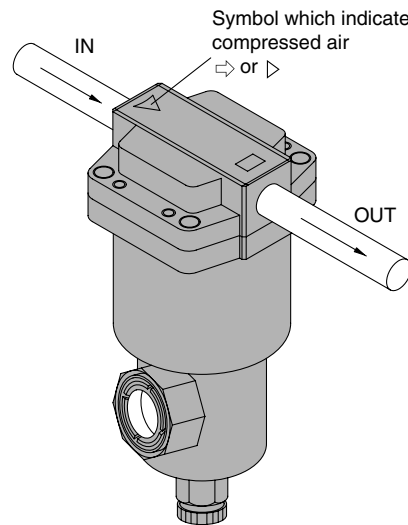

#### 2. Use an air blower to flush the piping before connecting the piping.

Use an air blower to thoroughly flush the piping, or wash the piping to remove any cutting chips, cutting oil, or debris from inside the piping before connecting them.

#### 3. Wrapping of sealant tape

When screwing in the pipes or fittings, make sure to prevent cutting chips or the sealant material on the threaded portion of the pipe from entering the piping. If sealant tape is to be used, leave about 1.5 to 2 ridges of threads uncovered.

#### 4. Modular connection

Mount the attached bracket on one side when connecting 2 sets. Mount the attached brackets on both sides when connecting 3 sets or more. As a guideline for the number of brackets, one bracket should be mounted for every 2 products.



# Series AM□/AFF

## Specific Product Precautions 3

Be sure to read this before handling. Refer to back pages 1 and 2 for Safety Instructions, and "Precautions for Handling Pneumatic Devices" (M-03-E3A) for Common Precautions.

### Air Supply

#### ⚠ Caution

**1. The mist separator is not applicable to gases other than compressed air.**

The mist separator is not applicable to gases other than compressed air (example: oxygen, hydrogen, flammable gas, mixed gas).

**2. Do not use compressed air that contains chemicals, organic solvents, salt, or corrosive gases.**

Do not use compressed gas containing chemicals, organic solvents, salt or corrosive gas. This can cause rust, damage to rubber and resin parts, or malfunction.

**3. Operate within the specified operating pressure range.**

Damage, failure, or malfunction may occur if the mist separator is operated above the maximum operating pressure.

If the mist separator is used below the minimum operating pressure, increase in the air-flow resistance due to clogging will have such influence that the desired flow rate cannot be obtained.

If the mist separator is used under a low pressure such as for a blower, conduct sufficient tests by users to confirm the specifications and performances.

### Operating Environment

#### ⚠ Caution

**1. Do not use in the following environments, as this can cause failure.**

- 1) In locations having corrosive gases, organic solvents, and chemical solutions, or in locations where these elements are likely to adhere to the equipment.
- 2) In locations where salt water, water, or water vapor could come in contact with the equipment.
- 3) In locations that is exposed to shocks and vibrations.

**2. Be careful about the contamination of the workpieces due to entrainment of the ambient air.**

If compressed air is used for air blow, compressed air blowing out from the blow nozzle may entrain foreign matter (solid particles and liquid particles) floating in the ambient air, blowing it against the workpieces and causing adhesion. Therefore, sufficient precautions must be taken about the ambient environment.

### Maintenance

#### ⚠ Caution

**1. Replace the element immediately when the time for its replacement has arrived.**

To replace the element, replace the O-ring and the gasket, too. For the replacement procedure, refer to the operating manual. (For element dimensions, refer to back page 6.)

**<Element replacement timing>**

a) AFF2C to 22C, 37B, 75B, AM□150C ~ 550C, 650, 850

The replacement interval for the element is when the pressure drop reaches 0.1 MPa or after two years of operation, whichever comes first. A pressure drop can be verified with the element service indicator (-T) or with differential pressure gauge (Made to Order).

b) AME

If the element has red spots, perform replacement even before the situation has not come to (a).

c) AMF

If the secondary side smells of oil, perform replacement even before the situation has not come to (a).

**2. Be sure to exhaust the drain accumulated in the filter container.**

Failure to discharge the drain will allow the accumulated drain to flow over to the outlet side.

When using the AFF2C to 22C, 37B, 75B, AM□150C to 550C, 650, 850 with drain cock, drain guide or ball valve, discharge the drain before the drainage level reaches the centre of the sight glass. If the drain is not discharged properly, it will flow over to the outlet side.

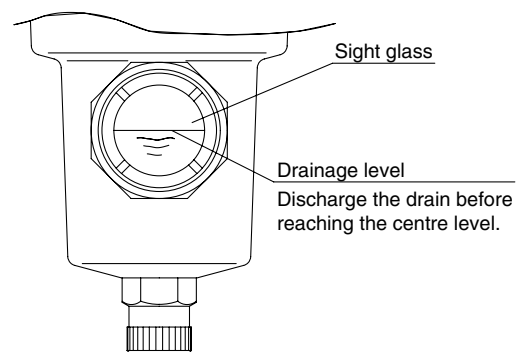





# Series AM□/AFF

## Specific Product Precautions 4

Be sure to read this before handling. Refer to back pages 1 and 2 for Safety Instructions, and “Precautions for Handling Pneumatic Devices” (M-03-E3A) for Common Precautions.

### Maintenance

#### ⚠ Caution

##### 3. In the case of a type with auto drain

- The auto drain operates when the drainage level reaches the top of the sight glass, and the drain will be discharged.
- When using the AFF2C to 22C, 37B, AM□150C to 550C, 650 with auto drain, the drain is automatically discharged with the knob tightened to the “S” side. Manual drain discharge, however, is also possible.

##### <Manual operation>

A manual knob attached to the auto drain end is tightened to the “S” side in normal operation. The drain can be discharged by loosening it to the “O” side. (Be careful, however, if pressure remains inside the filter when the drain is discharged, the drain will blow out from the drain port.)

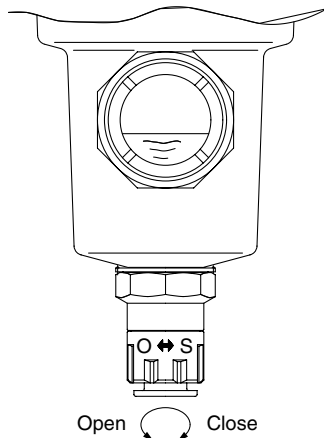

##### 4. The procedures and parts for the replacement of the drain port depend on the production period.

Description	Replacement parts name		Applicable size
	Produced in Dec. 2002 or before [Mfg. code: ~GZ]	Produced in Jan. 2003 or after [Mfg. code: HO~]	
Drain cock	AM-SA002		2C to 22C 2B to 37B 150C to 550C 150 to 650
Drain guide	AM-SA003-F		
N.O. auto drain	The auto drain cannot be replaced independently, and is included into the case assembly. (For the part number of the case assembly, refer to P206.)	Thread style Rc, G: AD43PA-D	2C to 22C 2B to 22B 150C to 550C 150 to 550
N.C. auto drain		Thread style NPT: NAD43PA-D	
Ball valve package	Thread style Rc, G: AD34PA-D		75B, 850
N.O. auto drain <sup>(Note)</sup>	Thread style Rc, G: NAD43PA-D		

Note) For the applicable size 75B and 850, a specific tool is necessary to replace the auto drain. (AM-SA005)

##### 5. The part number of the drain part depends on the option and thread style selected.

Applicable models: AFF2C~22C, AM, AMD, AMH, AMG150C~550C

Draining method	Option	Thread style G
Drain cock	F	AM-SA002-1
	V	AM-SA002-2
	FV	AM-SA002-3
Drain guide	F	AM-SA003-F-1
	V	AM-SA003-F-2
	FV	AM-SA003-F-3
N.O. auto drain	F	AD53PA-D-X155
	V	AD53PA-D-X113
N.C. auto drain	F	AD43PA-D-X155
	V	AD43PA-D-X113
	H	EAD33PA-D-X2004

### Others

#### ⚠ Caution

##### 1. Element interchange

Following is the element dimensions for the AFF and AM□ series:

Since elements for the same body size has the same dimensions, they are interchangeable.

However, do not interchange them easily since it can cause various kinds of problems.

If interchanging the elements is unavoidable, replace the product model number label, too.

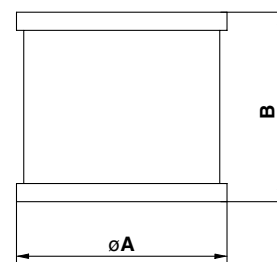

##### Element Dimensions

Model	Element dimensions (Reference value)	
	øA	B
AFF2C, AFF2B, AM150C, AM150 AMD150C, AMD150, AMH150C, AMH150	49	42
AFF4C, AFF4B, AM250C, AM250 AMD250C, AMD250, AMH250C, AMH250	58	52
AFF8C, AFF8B, AM350C, AM350 AMD350C, AMD350, AMH350C, AMH350	70	78
AFF11C, AFF11B, AM450C, AM450 AMD450C, AMD450, AMH450C, AMH450	82	88
AFF22C, AFF22B, AM550C, AM550 AMD550C, AMD550, AMH550C, AMH550	96	118
AFF37B, AM650 AMD650, AMH650	122	144
AFF75B, AM850 AMD850, AMH850	142	223



# Series AM□/AFF Specific Product Precautions 5

Be sure to read this before handling. Refer to back pages 1 and 2 for Safety Instructions, and "Precautions for Handling Pneumatic Devices" (M-03-E3A) for Common Precautions.

## Others

### ⚠ Caution

#### 2. About oil-free products

The AFF and AM□ series includes parts (such as resin parts, rubber parts, and elements) that does not allow degreasing wash. Therefore, oil-free products with all parts degreasing washed is not available.

#### 3. Degreasing wash

Certain parts such as the body and housing can be degreasing washed. Contact SMC after confirming the specifications. (available as Option or Made to Order)

#### 4. Change of oil

On the AFF and AM□ series, no oil such as grease is applied to parts exposed to compressed air. However, for certain specifications, there are some parts to which oil is applied. It is possible to change the type of applied oil (as Option or Made to Order).

### ⚠ Caution

#### 5. Internal volume of filter container

The product can be used as a small capacity air tank by removing the element.

Following is the volume of filter containers of the AFF and AM□ series (when the element is removed).

#### Volume Inside Filter

Model	Volume inside filter (Reference value) (cm <sup>3</sup> )
AFF2C, AFF2B, AM150C, AM150 AMD150C, AMD150, AMH150C, AMH150	250
AFF4C, AFF4B, AM250C, AM250 AMD250C, AMD250, AMH250C, AMH250	300
AFF8C, AFF8B, AM350C, AM350 AMD350C, AMD350, AMH350C, AMH350	600
AFF11C, AFF11B, AM450C, AM450 AMD450C, AMD450, AMH450C, AMH450	1000
AFF22C, AFF22B, AM550C, AM550 AMD550C, AMD550, AMH550C, AMH550	1500
AFF37B, AM650 AMD650, AMH650	3000
AFF75B, AM850 AMD850, AMH850	9000

## Discontinued Model and Equivalent Model

The AFF and AM□ series were remodeled to products introduced in this catalogue in 1988.

Along with the new models, old models were provided mainly for the purpose of maintenance. However, due to the aging of metal dies and extreme decline in the quantity, the procurement of parts and consequently the maintenance of the production system became difficult. For this reason, old models were discontinued in 1994, as detailed in the table below. Use the equivalent model listed there.

### Discontinued Model and Equivalent Model

Product name	Production discontinuance			Equivalent model			Page						
	Model	Period of production discontinuance for products	Period of production discontinuance for maintenance parts	External dimensions of product Width x Depth x Height	Model	External dimensions of product Width x Depth x Height							
Main Line Filter	AFF6	End of July '94	End of March '99	100 x 100 x 253	AFF4C	76 x 76 x 172	P.10						
	AFF22			150 x 140 x 446	AFF22C	122 x 122 x 259							
	AFF37			200 x 170 x 526	AFF37B	160 x 160 x 311							
	AFF55			280 x 280 x 497	AFF75B	220 x 220 x 461							
Mist Separator	AM200			End of July '94	End of March '99	63 x 63 x 191	AM150C	63 x 63 x 158	P.18				
	AM300					85 x 85 x 258	AM250C	76 x 76 x 172					
	AM400					120 x 120 x 236	AM350C	90 x 90 x 204					
	AM500					140 x 140 x 383	AM550C	122 x 122 x 259					
Micro Mist Separator	AM600					End of July '94	End of March '99	180 x 170 x 465	AM650	160 x 160 x 311	P.26		
	AMD100							63 x 63 x 136	AMD150C	63 x 63 x 158			
	AMD200							80 x 82 x 170	AMD250C	76 x 76 x 172			
	AMD300							90 x 90 x 233	AMD350C	90 x 90 x 204			
Odour Removal Filter	AMD400							End of July '94	End of March '99	140 x 140 x 380	AMD450C	106 x 106 x 225	P.52
	AMD500									140 x 140 x 490	AMD550C	122 x 122 x 259	
	AMD600									140 x 140 x 590	AMD650	160 x 160 x 311	
	AMF200									80 x 80 x 153	AMF250C	76 x 76 x 103	
	AMF300	End of July '94	End of March '99							90 x 90 x 216	AMF350C	90 x 90 x 132	P.52
	AMF400									140 x 140 x 250	AMF450C	106 x 106 x 151	
	AMF500									140 x 140 x 360	AMF550C	122 x 122 x 187	
	AMF600									140 x 140 x 460	AMF650	160 x 160 x 291	

Note) Some models have different heights depending on the port size. They are shown in parentheses.



**EUROPEAN SUBSIDIARIES:**

**Austria**

SMC Pneumatik GmbH (Austria).  
Girakstrasse 8, A-2100 Korneuburg  
Phone: +43 2262-622800, Fax: +43 2262-62285  
E-mail: office@smc.at  
http://www.smc.at

**France**

SMC Pneumatique, S.A.  
1, Boulevard de Strasbourg, Parc Gustave Eiffel  
Bussy Saint Georges F-77607 Marne La Vallée Cedex 3  
Phone: +33 (0)1-6476 1000, Fax: +33 (0)1-6476 1010  
E-mail: contact@smc-france.fr  
http://www.smc-france.fr

**Netherlands**

SMC Pneumatics BV  
De Ruyterkade 120, NL-1011 AB Amsterdam  
Phone: +31 (0)20-5318888, Fax: +31 (0)20-5318880  
E-mail: info@smcpneumatics.nl  
http://www.smcpneumatics.nl

**Spain**

SMC España, S.A.  
Zuazobidea 14, 01015 Vitoria  
Phone: +34 945-184 100, Fax: +34 945-184 124  
E-mail: post@smc.smces.es  
http://www.smc.eu

**Belgium**

SMC Pneumatics N.V./S.A.  
Nijverheidsstraat 20, B-2160 Wommelgem  
Phone: +32 (0)3-355-1464, Fax: +32 (0)3-355-1466  
E-mail: info@smcpneumatics.be  
http://www.smcpneumatics.be

**Germany**

SMC Pneumatik GmbH  
Boschring 13-15, D-63329 Egelsbach  
Phone: +49 (0)6103-4020, Fax: +49 (0)6103-402139  
E-mail: info@smc-pneumatik.de  
http://www.smc-pneumatik.de

**Norway**

SMC Pneumatics Norway A/S  
Vollsveien 13 C, Granfos Næringspark N-1366 Lysaker  
Tel: +47 67 12 90 20, Fax: +47 67 12 90 21  
E-mail: post@smc-norge.no  
http://www.smc-norge.no

**Sweden**

SMC Pneumatics Sweden AB  
Ekhagsvägen 29-31, S-141 71 Huddinge  
Phone: +46 (0)8-603 12 00, Fax: +46 (0)8-603 12 90  
E-mail: post@smcpneumatics.se  
http://www.smc.nu

**Bulgaria**

SMC Industrial Automation Bulgaria EOOD  
Business Park Sofia, Building 8 - 6th floor, BG-1715 Sofia  
Phone: +359 2 9744492, Fax: +359 2 9744519  
E-mail: office@smc.bg  
http://www.smc.bg

**Greece**

SMC Hellas EPE  
Anagenniseos 7-9 - P.C. 14342, N. Philadelphia, Athens  
Phone: +30-210-2717265, Fax: +30-210-2717766  
E-mail: sales@smchellas.gr  
http://www.smchellas.gr

**Poland**

SMC Industrial Automation Polska Sp.z.o.o.  
ul. Poloneza 89, PL-02-826 Warszawa  
Phone: +48 22 211 9600, Fax: +48 22 211 9617  
E-mail: office@smc.pl  
http://www.smc.pl

**Switzerland**

SMC Pneumatik AG  
Dorfstrasse 7, CH-8484 Weisslingen  
Phone: +41 (0)52-396-3131, Fax: +41 (0)52-396-3191  
E-mail: info@smc.ch  
http://www.smc.ch

**Croatia**

SMC Industrijska automatika d.o.o.  
Crnomerec 12, HR-10000 ZAGREB  
Phone: +385 1 377 66 74, Fax: +385 1 377 66 74  
E-mail: office@smc.hr  
http://www.smc.hr

**Hungary**

SMC Hungary Ipari Automatizálási Kft.  
Torbágy út 19, H-2045 Törökbalint  
Phone: +36 23 511 390, Fax: +36 23 511 391  
E-mail: office@smc.hu  
http://www.smc.hu

**Portugal**

SMC Sucursal Portugal, S.A.  
Rua de Eng<sup>o</sup> Ferreira Dias 452, 4100-246 Porto  
Phone: +351 226 166 570, Fax: +351 226 166 589  
E-mail: postpt@smc.smces.es  
http://www.smc.eu

**Turkey**

Entek Pnömatik San. ve Tic. A\*.  
Perpa Ticaret Merkezi B Blok Kat:11 No: 1625, TR-34386, Okmeydanı, Istanbul  
Phone: +90 (0)212-444-0762, Fax: +90 (0)212-221-1519  
E-mail: smc@entek.com.tr  
http://www.entek.com.tr

**Czech Republic**

SMC Industrial Automation CZ s.r.o.  
Hudcova 78a, CZ-61200 Brno  
Phone: +420 5 414 24611, Fax: +420 5 412 18034  
E-mail: office@smc.cz  
http://www.smc.cz

**Ireland**

SMC Pneumatics (Ireland) Ltd.  
2002 Citywest Business Campus, Naas Road, Saggart, Co. Dublin  
Phone: +353 (0)1-403 9000, Fax: +353 (0)1-464-0500  
E-mail: sales@smcpneumatics.ie  
http://www.smcpneumatics.ie

**Romania**

SMC Romania srl  
Str Frunzei 29, Sector 2, Bucharest  
Phone: +40 213205111, Fax: +40 213261489  
E-mail: smcromania@smcromania.ro  
http://www.smcromania.ro

**UK**

SMC Pneumatics (UK) Ltd  
Vincent Avenue, Crownhill, Milton Keynes, MK8 0AN  
Phone: +44 (0)800 1382930 Fax: +44 (0)1908-555064  
E-mail: sales@smcpneumatics.co.uk  
http://www.smcpneumatics.co.uk

**Denmark**

SMC Pneumatik A/S  
Egeskovvej 1, DK-8700 Horsens  
Phone: +45 70252900, Fax: +45 70252901  
E-mail: smc@smcdk.com  
http://www.smcdk.com

**Italy**

SMC Italia S.p.A  
Via Garibaldi 62, I-20061 Carugate, (Milano)  
Phone: +39 (0)2-92711, Fax: +39 (0)2-9271365  
E-mail: mailbox@smcitalia.it  
http://www.smcitalia.it

**Russia**

SMC Pneumatik LLC.  
4B Sverdlovskaja nab., St. Petersburg 195009  
Phone: +7 812 718 5445, Fax: +7 812 718 5449  
E-mail: info@smc-pneumatik.ru  
http://www.smc-pneumatik.ru

**Estonia**

SMC Pneumatics Estonia OÜ  
Laki 12, 106 21 Tallinn  
Phone: +372 6510370, Fax: +372 65110371  
E-mail: smc@smcpneumatics.ee  
http://www.smcpneumatics.ee

**Latvia**

SMC Pneumatics Latvia SIA  
Dzelzavas str. 120g, Riga LV-1021, LATVIA  
Phone: +371 67817700, Fax: +371 67817701  
E-mail: info@smclv.lv  
http://www.smclv.lv

**Slovakia**

SMC Priemyselna Automatizacia, s.r.o.  
Fatranská 1223, 01301 Teplicka Nad Váhom  
Phone: +421 41 3213212 - 6 Fax: +421 41 3213210  
E-mail: office@smc.sk  
http://www.smc.sk

**Finland**

SMC Pneumatics Finland Oy  
PL72, Tiistinniityntie 4, SF-02231 ESPOO  
Phone: +358 207 513513, Fax: +358 207 513599  
E-mail: smcffi@smc.fi  
http://www.smc.fi

**Lithuania**

SMC Pneumatics Lietuva, UAB  
Oslo g.1, LT-04123 Vilnius  
Phone: +370 5 264 81 26, Fax: +370 5 264 81 26

**Slovenia**

SMC industrijska Avtomatika d.o.o.  
Mirska cesta 7, SI-8210 Trebnje  
Phone: +386 7 3885412 Fax: +386 7 3885435  
E-mail: office@smc.si  
http://www.smc.si

**OTHER SUBSIDIARIES WORLDWIDE:**

ARGENTINA, AUSTRALIA, BOLIVIA, BRASIL, CANADA, CHILE,  
CHINA, HONG KONG, INDIA, INDONESIA, MALAYSIA, MEXICO,  
NEW ZEALAND, PHILIPPINES, SINGAPORE, SOUTH KOREA,  
TAIWAN, THAILAND, USA, VENEZUELA

<http://www.smc.eu>  
<http://www.smcworld.com>