

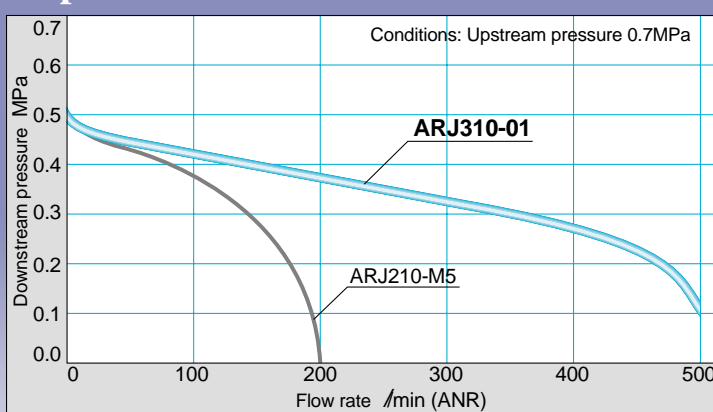

Miniature Regulator Series **ARJ310**



Improved flow characteristics



Compact and light weight Allows smaller mounting pitch

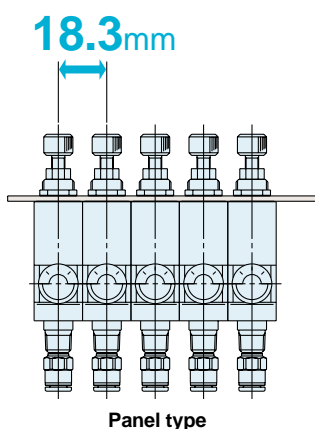
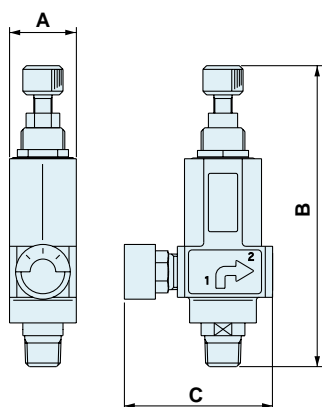

Accommodates two types of threads

Inside: Female thread (M5 x 0.8)
Outside: Male thread (1/8)



One-touch fitting feature introduced to series

ø4, ø6 (metric size)
ø5/32", ø1/4" (inch size)

Model	A (Width)	B (Height)	C (Depth)	Weight
ARJ310-01G	18.3	82.5	Approx. 41	Approx. 70g (Body: 65g)
ARJ210-M5G	18.3	80	Approx. 46	Approx. 75g (Body: 60g)

Miniature Regulator

Series ARJ310

How to Order

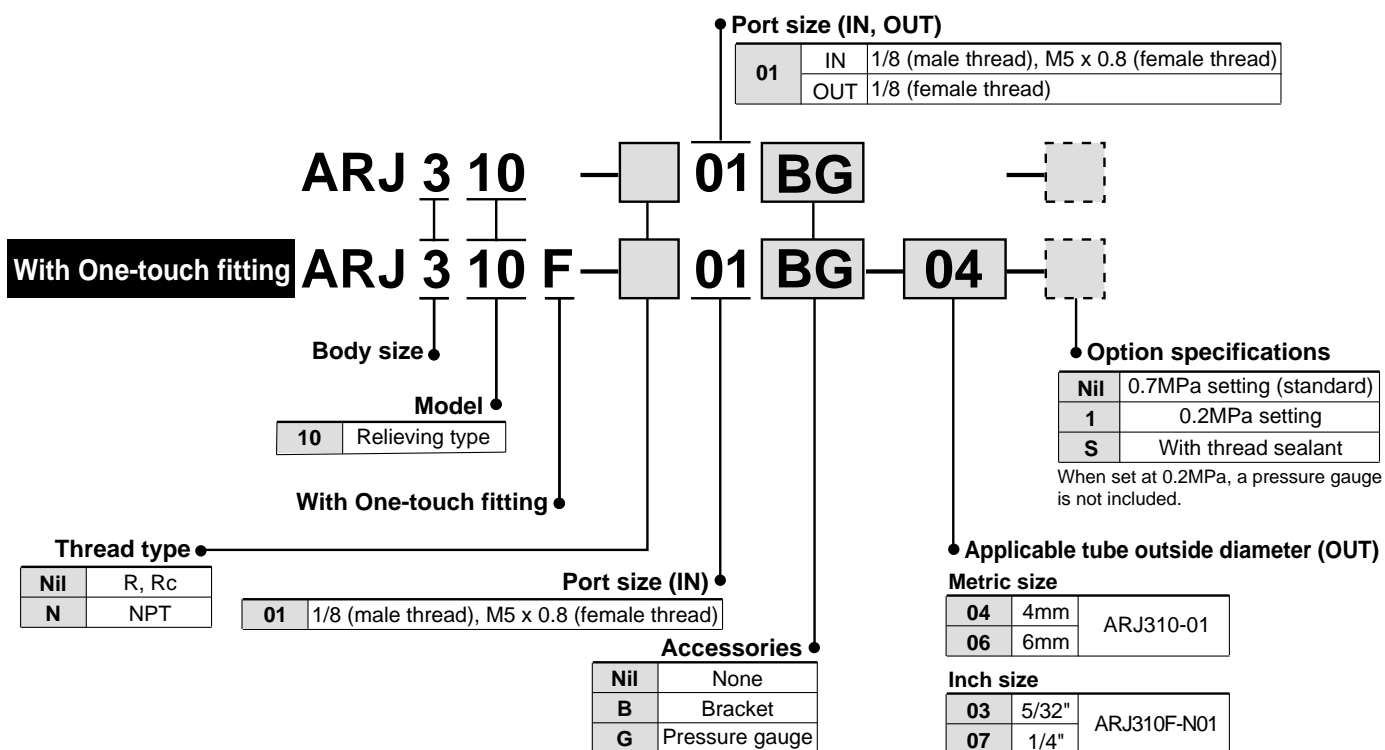

Model



Model	Port size	
	IN (Note)	OUT
ARJ310-01	R 1/8, M5 x 0.8	Rc 1/8
ARJ310-N01	NPT 1/8, M5 x 0.8	NPT 1/8
ARJ310F-01-04	R 1/8, M5 x 0.8	ø4 One-touch fitting
ARJ310F-01-06		ø6 One-touch fitting
ARJ310F-N01-03	NPT 1/8, M5 x 0.8	ø5/32 One-touch fitting
ARJ310F-N01-07		ø1/4 One-touch fitting

Note) M5 x 0.8 female thread is cut inside the pipe.

Standard Specifications

Pressure gauge port size	Rc 1/8, NPT 1/8 (female thread)
Fluid	Air
Proof pressure	1.2MPa
Maximum operating pressure	0.8MPa
Regulating pressure range	Standard: 0.2 to 0.7MPa, Low pressure use (0.2MPa setting): 0.05 to 0.2MPa
Ambient and operating temperature range	-5 to 60°C (with no freezing)
Weight	Approx. 65g

Optional Accessory Part Numbers

Bracket	134856
Pressure gauge (Note)	G15-10-01 (Rc 1/8)/G15-P10-N01(NPT 1/8)

Note) Pressure gauges for 0.2MPa are not available.

Flow Characteristics

Conditions: Upstream pressure 0.7MPa

ARJ310-01

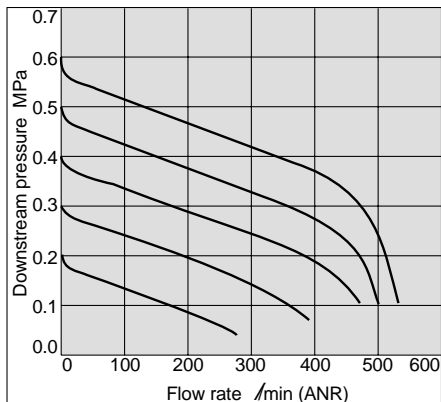

ARJ310F-01-04

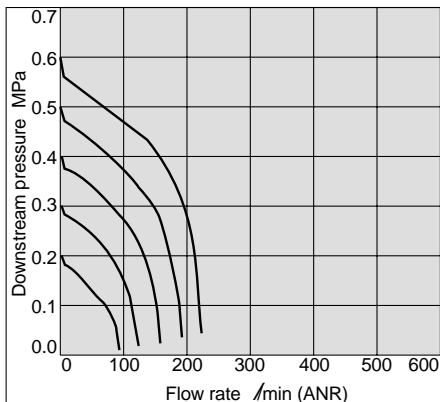

ARJ310F-01-06

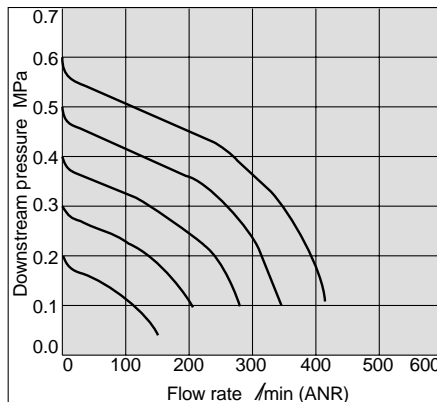

Pressure Characteristics

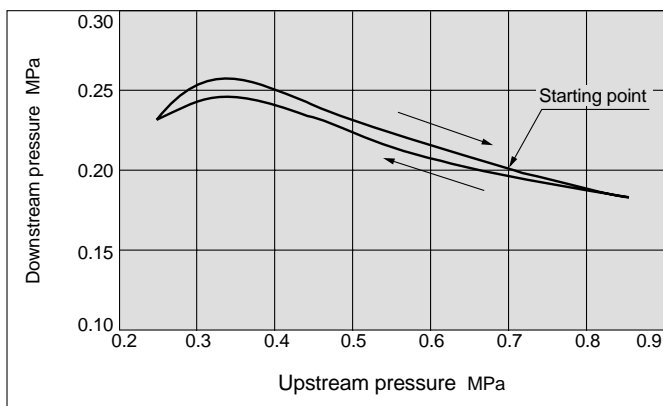

Conditions:
Upstream pressure 0.7MPa
Downstream pressure 0.2MPa
Flow rate Q = 20 l/min (ANR)

Construction

ARJ310-01

ARJF310F-01

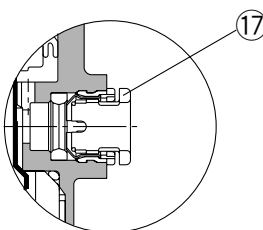
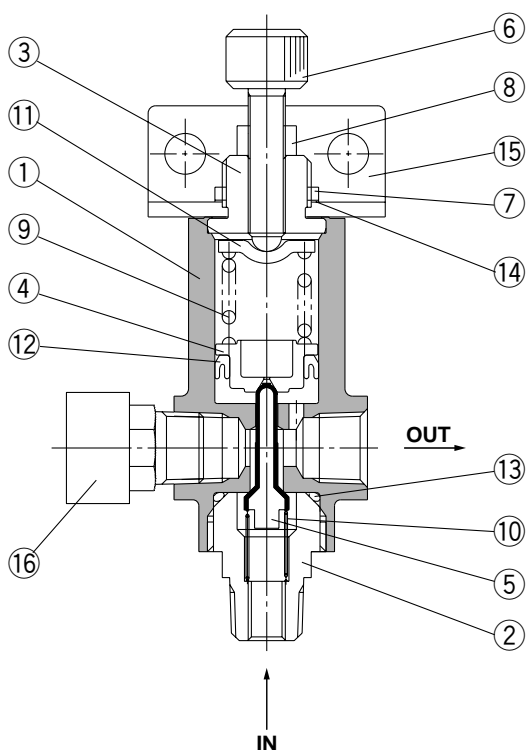

Parts list

No.	Description	Material	Note
1	Body	Aluminum alloy	
2	Valve guide	Brass	Electroless nickel plated
3	Bonnet	Brass	Electroless nickel plated
4	Piston	POM	
5	Valve	Brass	Rubber lining material: HNBR
6	Adjusting screw	Brass	Electroless nickel plated
7	Panel nut	Brass	Electroless nickel plated
8	Hexagon nut	Brass	Electroless nickel plated
9	Adjusting spring	Steel wire	Zinc chromated
10	Valve spring	Stainless steel	
11	Spring holder	Steel band	Zinc chromated
12	Mini Y seal	NBR	
13	O-ring	NBR	
14	Lock washer	SS	Electroless nickel plated
15	Bracket	Steel band	Black zinc chromated
16	Pressure gauge	-	Accessory
17	Cassette	POM, Stainless steel	

Series ARJ310

Dimensions

ARJ310-01

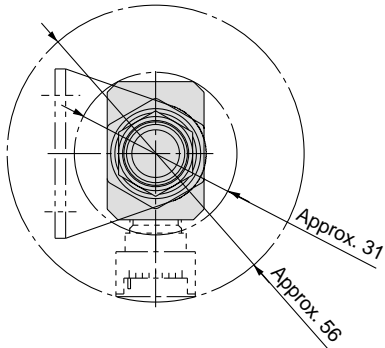

ARJ310F-01

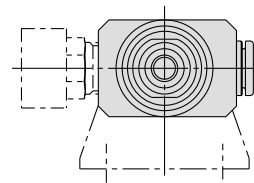
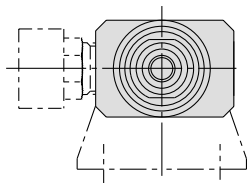
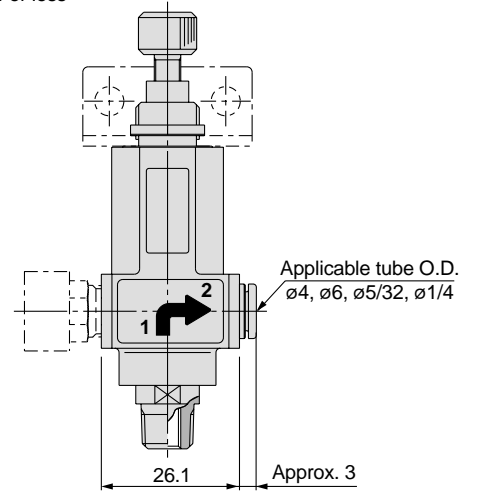
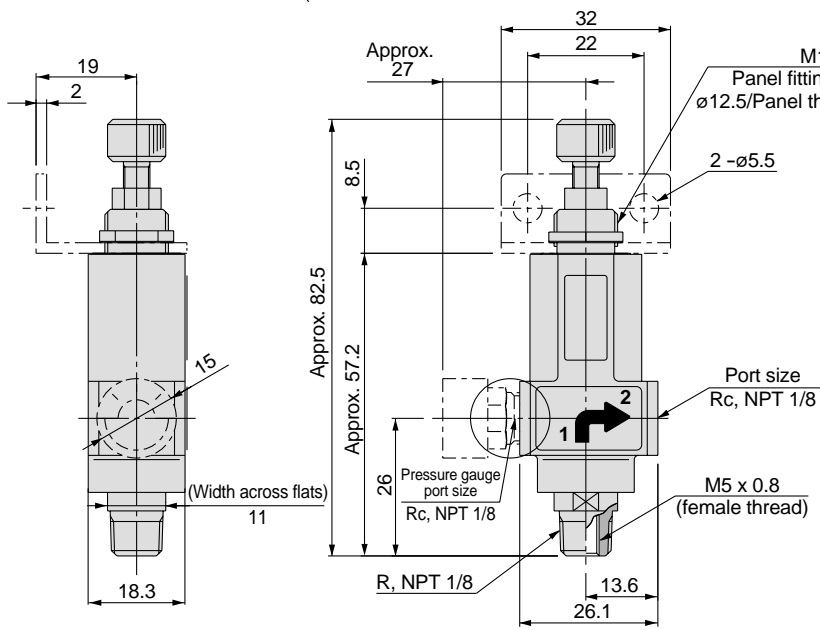
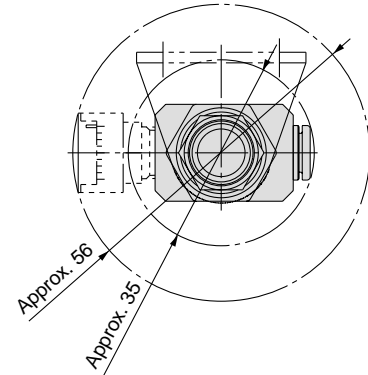





Series ARJ310 Safety Instructions

These safety instructions are intended to prevent a hazardous situation and/or equipment damage. These instructions indicate the level of potential hazard by labels of "**Caution**", "**Warning**" or "**Danger**". To ensure safety, be sure to observe ISO 4414 ^{Note 1)}, JIS B 8370 ^{Note 2)} and other safety practices.

 **Caution:** Operator error could result in injury or equipment damage.

 **Warning:** Operator error could result in serious injury or loss of life.

 **Danger:** In extreme conditions, there is a possible result of serious injury or loss of life.

Note 1) ISO 4414 : Pneumatic fluid power – Recommendations for the application of equipment to transmission and control systems

Note 2) JIS B 8370 : General Rules for Pneumatic Equipment

Warning

1. The compatibility of pneumatic equipment is the responsibility of the person who designs the pneumatic system or decides its specifications.

Since the products specified here are used in various operating conditions, their compatibility for the specific pneumatic system must be based on specifications or after analysis and/or tests to meet your specific requirements.

2. Only trained personnel should operate pneumatically operated machinery and equipment.

Compressed air can be dangerous if an operator is unfamiliar with it. Assembly, handling or repair of pneumatic systems should be performed by trained and experienced operators.

3. Do not service machinery/equipment or attempt to remove components until safety is confirmed.

1. Inspection and maintenance of machinery/equipment should only be performed after confirmation of safe locked-out control positions.
2. When equipment is to be removed, confirm the safety process as mentioned above. Cut the supply pressure for this equipment and exhaust all residual compressed air in the system.
3. Before machinery/equipment is restarted, take measures to prevent shooting-out of cylinder piston rod, etc. (Bleed air into the system gradually to create back-pressure.)

4. Contact SMC if the product is to be used in any of the following conditions:

1. Conditions and environments beyond the given specifications, or if product is used outdoors.
2. Installation on equipment in conjunction with atomic energy, railway, air navigation, vehicles, medical equipment, food and beverages, recreation equipment, emergency shutdown circuits, press applications, or safety equipment.
3. An application which has the possibility of having negative effects on people, property, or animals, requiring special safety analysis.



Series ARJ310 Miniature Regulator Precautions 1

Be sure to read before handling.

Design and Selection

⚠ Warning

1. Confirm the specifications.

The products included in this catalog are designed for use only in compressed air systems.

Do not use them outside the specified ranges of pressure, temperature, etc., as this can cause damage or malfunction.

Consult SMC if fluids other than compressed air are to be used.

2. Confirm the regulating pressure range.

Be sure to install safety devices in locations where output pressure beyond the regulating pressure range can lead to damage or malfunction of equipment downstream.

3. Residual pressure relief without supply pressure

In cases where the supply pressure is removed with the downstream pressure in a low pressure setting state, it may not be possible to eliminate the downstream pressure (residual pressure relief).

To ensure reliable elimination of the downstream pressure, provide a residual pressure relief circuit.

4. When used with a closed downstream circuit and balance circuit

Contact SMC as there are cases where the regulator cannot be used.

5. Perform downstream pressure setting in a range that is 85% or less of the supply pressure.

However, the setting should be within the regulating pressure range.

6. This regulator cannot be used as a check type regulator to be installed between a solenoid valve and an actuator. It can cause breakdown and malfunction.

7. When piping, tighten the regulator with the recommended proper tightening torque (M5: 1.5 to 2N·m, R1/8: 7 to 9N·m) while holding the wrench flats (width 11) of the valve guide for the IN port and holding the hexagonal section of the body for the OUT port. Excessive tightening or holding a part other than those specified can cause damage.

8. When piping or operating the knob, do not apply excessive bending moment to the regulator. It can cause damage.

⚠ Caution

Pressure gauge

1. Be sure that the body does not receive direct impact or vibrations.
2. Contact SMC when using this regulator with pressure pulsation and high-frequency operation.

Mounting

⚠ Warning

1. Read the instruction manual

carefully.

Mount and operate the regulator with a good understanding of the contents of the manual. Also, keep the manual in a location where it can be referred to at any time.

2. Ensure space for maintenance.

Ensure the necessary space for maintenance work.

3. Strictly observe the tightening of screws and the recommended tightening torques.

When mounting the regulator, use the recommended tightening torques stated in the table below.

PT, NPT, PF	Recommended tightening torque
M5	1.5 to 2N·m
1/8	7 to 9N·m

4. Set pressure while confirming upstream and downstream pressure readings on a pressure gauge. Excessive turning of the knob can damage internal parts.

⚠ Caution

1. To set the correct pressure

1. Set the pressure by increasing from a lower pressure to the desired setting, and lock the knob after the pressure is set.
2. Make connections after confirming the  mark which indicates the air inlet. Reversed connections can cause malfunction.

2. Adjust the pressure with the lock released, and lock the knob again after adjustment is made.

If the procedure is not followed, it can damage the knob or cause fluctuation in the downstream pressure.

<How to use the lock>

The lock is released by loosening the lock nut and is engaged by tightening the lock nut.

Pressure gauge

1. Do not apply impact to a pressure gauge from dropping, etc., when carrying it and at installation. It will damage the reading precision.
2. Mount the pressure gauge with the zero point of the pressure gauge scale pointing downward and perpendicular to the ground.
3. Do not mount the pressure gauge in locations with high temperatures and humidity. Such conditions cause malfunction.

Mounting

⚠ Caution

4. When screwing the pressure gauge into the body, be sure to do it holding the hexagon flats securely with a wrench. If done by holding other parts, it can cause air leakage and damage.

Piping

⚠ Caution

1. Preparation before piping

Before piping is connected, air blow (flush) or wash it thoroughly to remove chips, cutting oil and other impurities from inside the piping.

2. Wrapping of sealant tape

When screwing piping or fittings into the body, be sure that chips from the pipe threads and sealing material do not get inside the piping.

Furthermore, when sealant tape is used, leave 1.5 to 2 thread ridges exposed at the end of the threads.

Air Supply

⚠ Warning

1. Types of fluid

This regulator is designed for use with compressed air. Consult SMC if a different fluid is to be used.

2. Type of air

Compressed air that contains substances such as organic solvents, synthetic oils, chemicals, salts or corrosive gases can cause damage and malfunction of the equipment.

Operating Environment

⚠ Warning

1. Do not operate in environments with corrosive gases, chemicals, sea water, fresh water or water vapor, or where there will be contact with the same.
2. In locations exposed to direct sunlight, block the sunlight.
3. Do not operate in locations where vibration or impact occurs.
4. Do not operate in a location near a heat source where radiated heat will be received.



Series ARJ310 Miniature Regulator Precautions 2

Be sure to read before handling.

Maintenance

Warning

1. Maintenance operations

Improper handling of compressed air is dangerous. Therefore, in addition to observing the product specifications, replacement of elements and other maintenance work should be performed by personnel having sufficient knowledge and experience pertaining to pneumatic equipment.

2. Pre-maintenance procedures

When removing this regulator, turn off the electric power, and be certain to shut off the supply pressure and exhaust the compressed air in the system. Proceed with maintenance work only after confirming that all pressure has been released to the atmosphere.

3. Post-maintenance procedures

After installation, repair or modification work, reconnect compressed air and electric power, and then perform inspections for proper operation and air leakage. If the air leakage noise can be heard, or if the equipment does not operate properly, stop operation and confirm that it is installed correctly.

4. Modification prohibited

Do not modify or reconstruct the unit.

Handling of One-touch Fittings

Caution

1. Tube attachment/detachment for One-touch fittings

1) Attaching a tube

1. Take a tube having no flaws on its periphery and cut it off at a right angle. When cutting the tube, use tube cutters TK-1, 2 or 3. Do not use pliers, nippers or scissors, etc. If cutting is done with tools other than tube cutters, the tube may be cut diagonally or become flattened, etc. This can make a secure installation impossible, and cause problems such as the tube coming loose after installation or air leakage. Allow some extra length in the tube.

2. Hold the tube and push it in slowly, inserting it all the way into the fitting.

3. After inserting the tube, pull on it lightly to confirm that it will not come out. If it is not installed securely all the way into the fitting, this can cause problems such as air leakage or the tube pulling out.

2) Detaching a tube

1. Push in the release button sufficiently. When doing this, push the collar evenly.

2. Pull out the tube while holding down the release button so that it does not snap back. If the release button is not pressed down sufficiently, there will be increased bite on the tube and it will become more difficult to remove it.

3. When the removed tube is to be used again, cut off the portion which has been chewed before reusing it. If the chewed portion of the tube is used as is, this can cause problems such as air leakage or difficulty in removing the tube.

2. When mounting a One-touch fitting, use a suitable wrench to tighten the hexagonal flats of the fitting.

Moreover, position the wrench at the lower part of the hexagonal flats as close to the threads as possible. When a wrench of the proper size for the hexagonal flats is not used, it will cause damage to the hexagonal flats.

3. Tightening of the M5 threads

1) M5

After tightening by hand, give an additional 1/6 rotation with the correct tool.

Overtightening can cause damage to the threads and/or air leakage due to deformation of the gasket. Undertightening can cause loose threads and air leakage, etc.

Precautions on Tube by Other Manufactures

Caution

1. When using tubes by manufactures other than SMC, confirm that the tube's outside diameter tolerance satisfy the following specifications.

1) Nylon tubing: $\pm 0.1\text{mm}$ or less

2) Soft nylon tubing: $\pm 0.1\text{mm}$ or less

3) Polyurethane tubing:

+0.15mm or less,

-0.2mm or less

Do not use a tube if the outside diameter tolerance is not satisfied. It may not be possible to connect the tubing, or leakage or disconnection may occur after connecting.



SMC'S GLOBAL MANUFACTURING, DISTRIBUTION AND SERVICE NETWORK

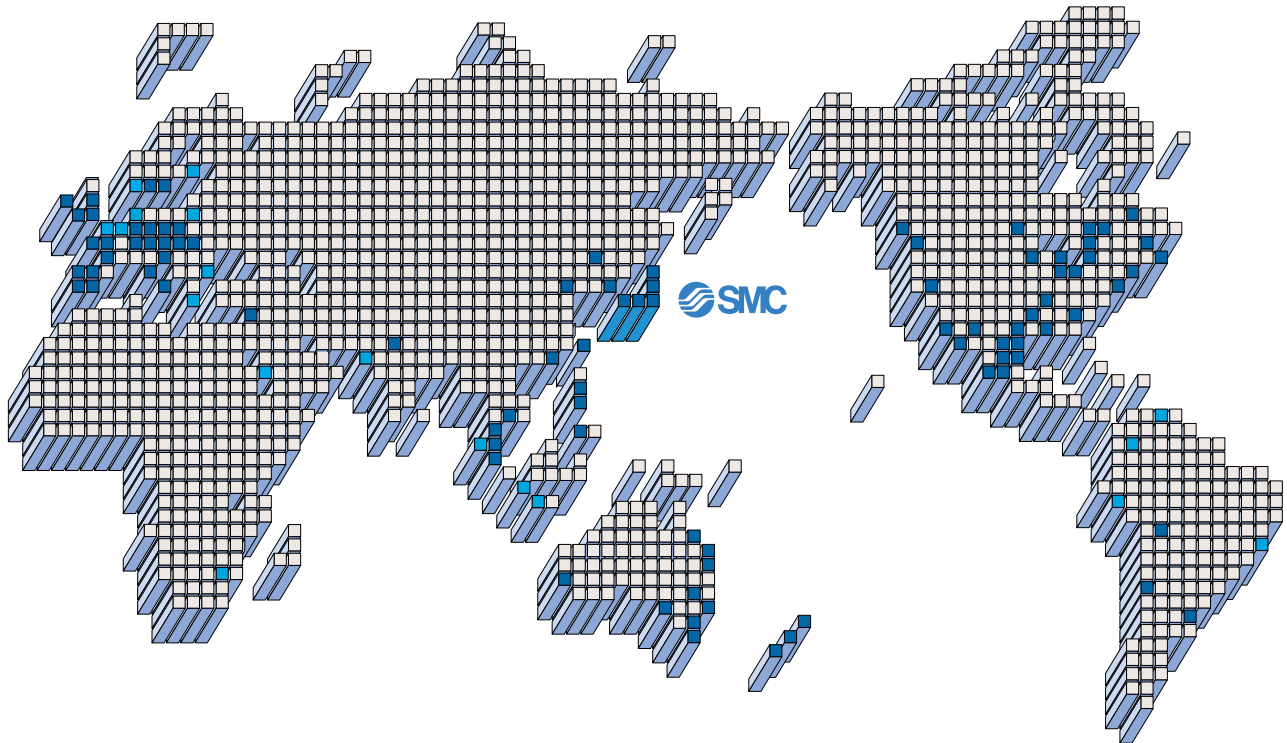

EUROPE

AUSTRIA

SMC Pneumatik GmbH

CZECH

SMC Czech s.r.o.

DENMARK

SMC Pneumatik A/S

FINLAND

SMC Pneumatiikka OY

FRANCE

SMC Pneumatique SA

GERMANY

SMC Pneumatik GmbH

HUNGARY

SMC Hungary Kft.

IRELAND

SMC Pneumatics (Ireland) Ltd.

ITALY

SMC Italia S.p.A.

NETHERLANDS

SMC Pneumatics BV.

NORWAY

SMC Pneumatics Norway A/S

POLAND

SMC Industrial Automation Polska Sp.z.o.o.

ROMANIA

SMC Romania s.r.l.

RUSSIA

SMC Pneumatik LLC.

SLOVAKIA

SMC Slovakia s.r.o.

EUROPE

SLOVENIA

SMC Slovenia d.o.o.

SPAIN/PORTUGAL

SMC España, S.A.

SWEDEN

SMC Pneumatics Sweden AB

SWITZERLAND

SMC Pneumatik AG.

UK

SMC Pneumatics (U.K.) Ltd.

ASIA

CHINA

SMC (China) Co., Ltd.

HONG KONG

SMC Pneumatics (Hong Kong) Ltd.

INDIA

SMC Pneumatics (India) Pvt. Ltd.

MALAYSIA

SMC Pneumatics (S.E.A.) Sdn. Bhd.

PHILIPPINES

SMC Pneumatics (Philippines), Inc.

SINGAPORE

SMC Pneumatics (S.E.A.) Pte. Ltd.

SOUTH KOREA

SMC Pneumatics Korea Co., Ltd.

TAIWAN

SMC Pneumatics (Taiwan) Co., Ltd.

THAILAND

SMC Thailand Ltd.

NORTH AMERICA

CANADA

SMC Pneumatics (Canada) Ltd.

MEXICO

SMC Corporation (Mexico) S.A. de C.V.

USA

SMC Pneumatics, Inc.

SOUTH AMERICA

ARGENTINA

SMC Argentina S.A.

BOLIVIA

SMC Pneumatics Bolivia S.R.L.

BRAZIL

SMC Pneumaticos Do Brazil Ltda.

CHILE

SMC Pneumatics (Chile) S.A.

VENEZUELA

SMC Neumatica Venezuela S.A.

OCEANIA

AUSTRALIA

SMC Pneumatics (Australia) Pty. Ltd.

NEW ZEALAND

SMC Pneumatics (N.Z.) Ltd.

SMC CORPORATION

1-16-4 Shimbashi, Minato-ku, Tokyo 105-0004, JAPAN

Tel: 03-3502-2740 Fax: 03-3508-2480

URL <http://www.smcworld.com>

© 2000 SMC CORPORATION All Rights Reserved

1st printing January, 2001 D-SMC.L.A. P-80 (N)

This catalog is printed on recycled paper with concern for the global environment.

Specifications are subject to change without prior notice and any obligation on the part of the manufacturer.

Printed in Japan.