

SKF

SKF Inch Linear Bushing Series

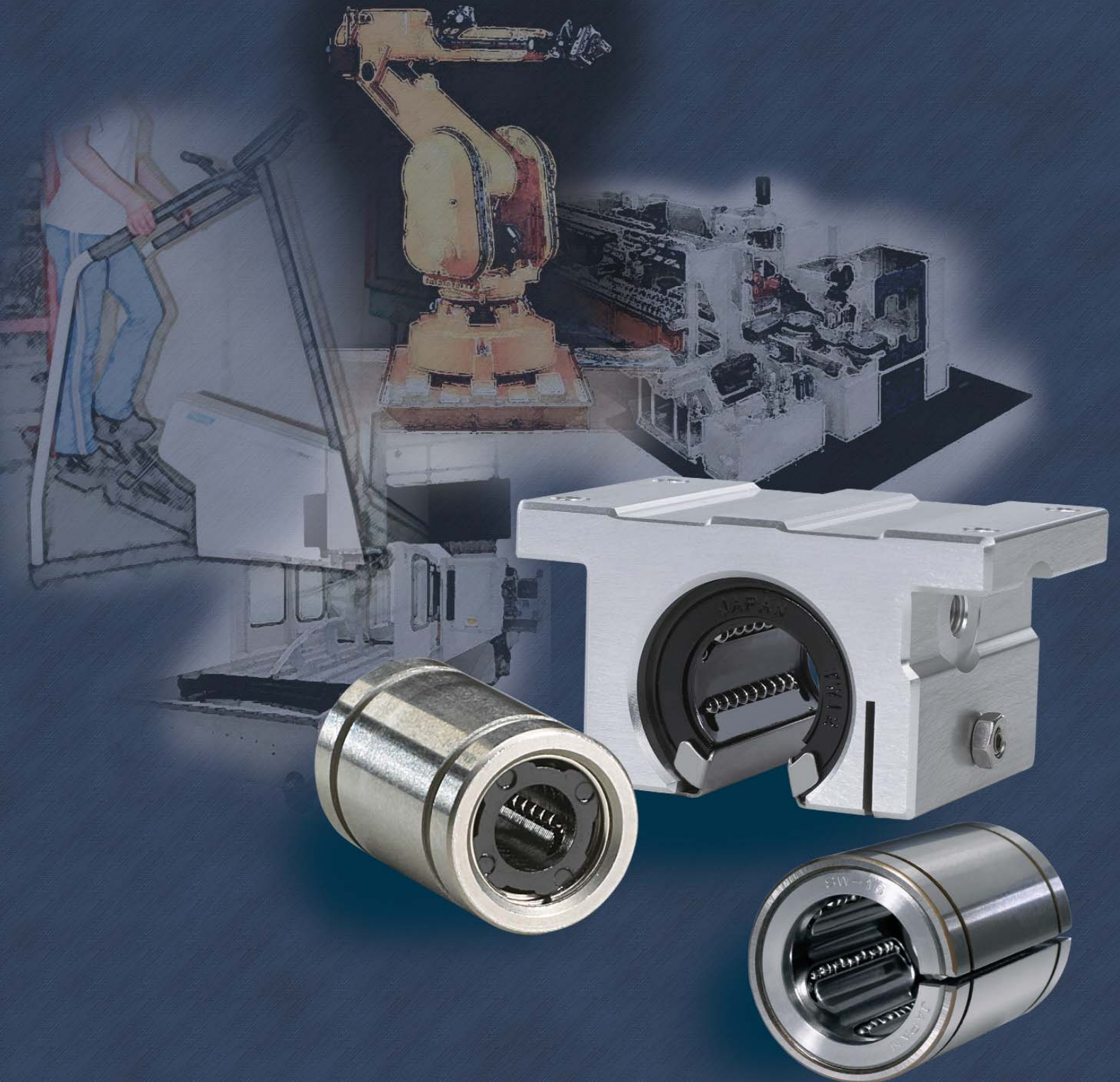

SKF Inch Linear Bushing Series

SKF®, the worlds leading supplier of ball and roller bearings, is also a major player in the worldwide linear motion market. We offer a complete range of linear motion products that includes ball and roller screws, linear actuators, profile rails (square rail) and precision rail products. In addition, we offer a complete line of metric and inch linear ball bearings and shafting.

The following information highlights SKF's new line of Inch Series Linear Ball Bearings and Housings. Our goal is to offer the market a full line of high-quality linear motion products so that SKF will be the primary source for solutions to all of your linear motion needs.

If you have any questions or comments, please call our toll free number at 1 (800) 541-3624. Our engineers will be happy to assist you with any of your technical questions or provide immediate interchanges. In addition, our customer service department is ready to help you with any questions concerning price and delivery.

Table of Content	Page
LBXR Type2 Standard	
LBXR/AJ Type4 Clearance Adjustable	
LBXT Type6 Open	
LBXD/LBXF Type8 Self-Aligning Inch	
LUXD Type10 Block	
LUXD/AJ Type11 Clearance Adjustable Block	
LTXD Type12 Tandem Block	
LTXD/AJ Type13 Clearance Adjustable Tandem Block	
LUXF Type14 Open Block	
LTXF Type15 Tandem Open Block	
Interchange16	



LBXR Type

Standard Type

This type is an inch dimension series mainly used in the U.S.

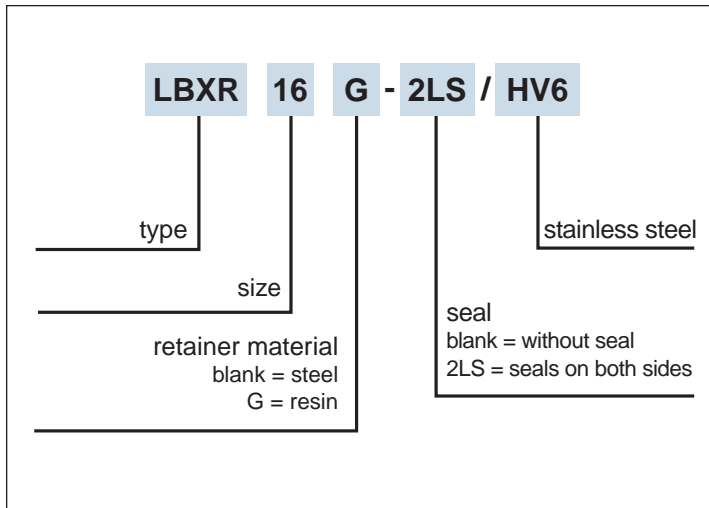

Part Number			Number of ball circuits	dr		D	
Standard		Stainless Steel		inch mm	tolerance	inch mm	tolerance
Steel retainer	Resin retainer	Resin retainer			inch/ μm		inch/ μm
-	-	LBXR 2G/HV6	4	.1250 3.175	0 -.00035	.3125 7.938	0 -.00040
-	-	LBXR 3G/HV6	4	.1875 4.763	0 -8	.3750 9.525	0 -9
LBXR 4	LBXR 4G	LBXR 4G/HV6	3*	.2500 6.350		.5000 12.700	⁰ -.00045 ₀ -11
LBXR 6	LBXR 6G	LBXR 6G/HV6	4	.3750 9.525	0 -.00040	.6250 15.875	0
LBXR 8	LBXR 8G	LBXR 8G/HV6	4	.5000 12.700	0 -9	.8750 22.225	-.00050 0
LBXR 10	LBXR 10G	LBXR 10G/HV6	4	.625 15.875		1.1250 28.575	-13
LBXR 12	LBXR 12G	LBXR 12G/HV6	5	.7500 19.050	0 -.00040	1.2500 31.750	0 -.00065
LBXR 16	LBXR 16G	LBXR 16G/HV6	6	1.0000 25.400	0 -10	1.5625 39.688	0 -16
LBXR 20	LBXR 20G	LBXR 20G/HV6	6	1.2500 31.750	0	2.0000 50.800	0 -.00075
LBXR 24	LBXR 24G	LBXR 24G/HV6	6	1.5000 38.100	-.00050 0	2.3750 60.325	0 -19
LBXR 32	LBXR 32G	LBXR 32G/HV6	6	2.0000 50.800	-12	3.0000 76.200	0
LBXR 40	-	-	6	2.5000 63.500	0 -.00060	3.7500 95.250	-.00090 0
LBXR 48	-	-	6	3.0000 76.200	0 -15	4.5000 114.300	-22
LBXR 64	-	-	6	4.0000 101.600	⁰ -.00080 ₀ -20	6.0000 152.400	⁰ -.00100 ₀ -25

*4 rows for resin retainer type.

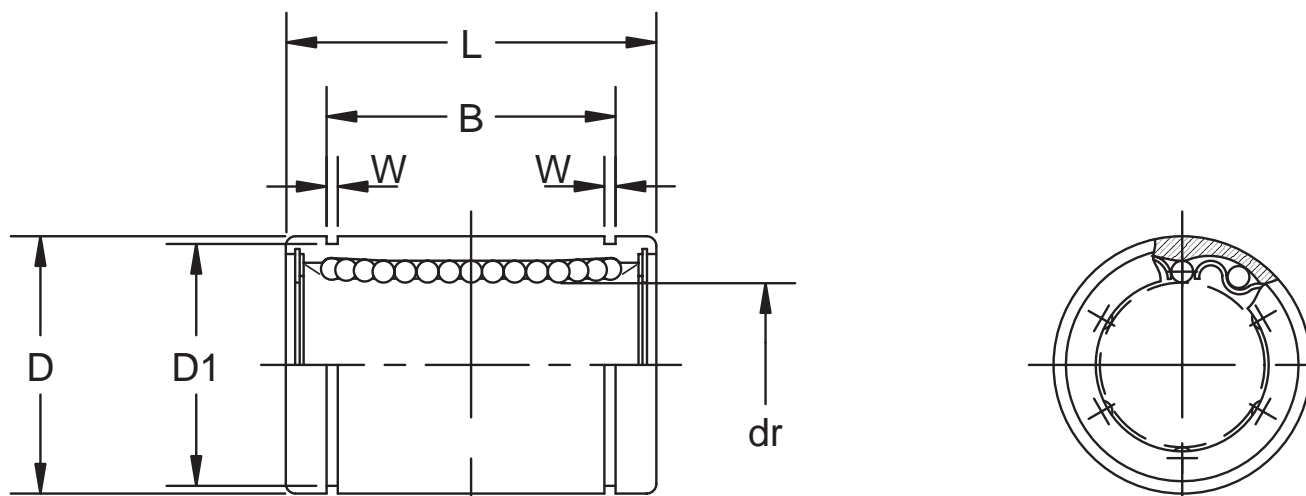

Major dimensions						eccentricity		radial clearance (maximum) inch/ μ m	Basic load rating		mass g	shaft diameter inch mm
inch mm	tolerance inch/mm	inch mm	tolerance inch/mm	inch mm	inch mm	precision inch/ μ m	high inch/ μ m		C lbs	Co lbs		
.5000 12.700		.3681 9.35		.0280 0.710	.2902 7.370	-		-.0001 -2	13	17	2.8	1/8 3.175
.5625 14.275		.4311 10.95		.0280 0.710	.3520 8.940		.0003 8		20	24	3.6	3/16 4.763
.7500 19.050	0 -.008	.5110 12.98	0 -.008	.0390 0.992	.4687 11.906			-.0001 -3	46	59	9.5	1/4 6.350
.8750 22.225		.6358 16.15		.0390 0.992	.5880 14.935	.0003	.0005		50	70	15	3/8 9.525
1.2500 31.750	0 -0.2	.9625 24.46	0 -0.2	.0459 1.168	.8209 20.853	8	12	-.0001 -4	114	176	42	1/2 12.700
1.5000 38.100		1.1039 28.04		.0559 1.422	1.0590 26.899				173	265	85	5/8 15.875
1.6250 41.275		1.1657 29.61		.0559 1.422	1.1760 29.870	.0004	.0006	-.0002 -6	193	307	104	3/4 19.050
2.2500 57.150		1.7547 44.57		.0679 1.727	1.4687 37.306	10	15		220	352	220	1 25.400
2.6250 66.675	0	2.0047 50.92	0	.0679 1.727	1.8859 47.904	.0005	.0008	-.0003 -8	352	615	465	1-1/4 31.750
3.0000 76.200	-.012 0	2.4118 61.26	-.012 0	0.859 2.184	2.2389 56.870	12	20		490	903	720	1-1/2 38.100
4.0000 101.600	-0.3	3.1917 81.07	-0.3	.1029 2.616	2.8379 72.085	.0007	.0010	-.0005 -13	858	1,784	1,310	2 50.800
5.0000 127.000		3.9760 100.99		.1200 3.048	3.5519 90.220	17	25		1,056	2,247	2,600	2-1/2 63.500
6.0000 152.400	0 -.016	4.726 120.04	0 -.016	.1200 3.048	4.3100 109.474			-.0008 -20	1,651	3,595	4,380	3 76.200
8.0000 203.200	0 -0.4	6.258 158.95	0 -0.4	.1389 3.530	5.745 145.923	.0008	.0012		3,168	7,820	10,200	4 101.600

1kg=2.205lbs

LBXR/AJ Type

Clearance Adjustable Type

This type is an inch dimension series mainly used in the U.S.

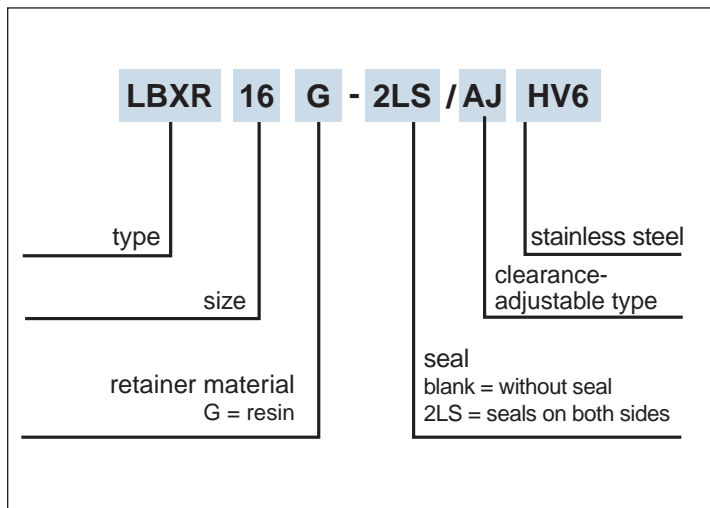

Part Number		Number of ball circuits	dr		D	
Standard	Stainless Steel		inch mm	tolerance* inch/ μ m	inch mm	tolerance* inch/ μ m
Resin retainer	Resin retainer					
LBXR4G/AJ	LBXR4G/AJHV6	4	.2500 6.350	0 -0.00040 0 -9 0 -0.00040 0 -10 0 -0.00050 0 -12	.5000 12.700	0 -0.00045 0 -11
LBXR6G/AJ	LBXR6G/AJHV6	4	.3750 9.525		.6250 15.875	0 0
LBXR8G/AJ	LBXR8G/AJHV6	4	5.000 12.700		.8750 22.225	-0.00050 0
LBXR10G/AJ	LBXR10G/AJHV6	4	.625 15.875		1.1250 28.575	-13
LBXR12G/AJ	LBXR12G/AJHV6	5	.7500 19.050		1.2500 31.750	0 -0.0065
LBXR16G/AJ	LBXR16G/AJHV6	6	1.0000 25.400		1.5625 39.688	0 -16
LBXR20G/AJ	LBXR20G/AJHV6	6	1.2500 31.750		2.0000 50.800	0 -0.00075
LBXR24G/AJ	LBXR24G/AJHV6	6	1.5000 38.100		2.3750 60.325	0 -19
LBXR32G/AJ	LBXR32G/AJHV6	6	2.0000 50.800		3.0000 76.200	0 -0.00090 0 -22

* Accuracy is measured prior to machining clearance slot.

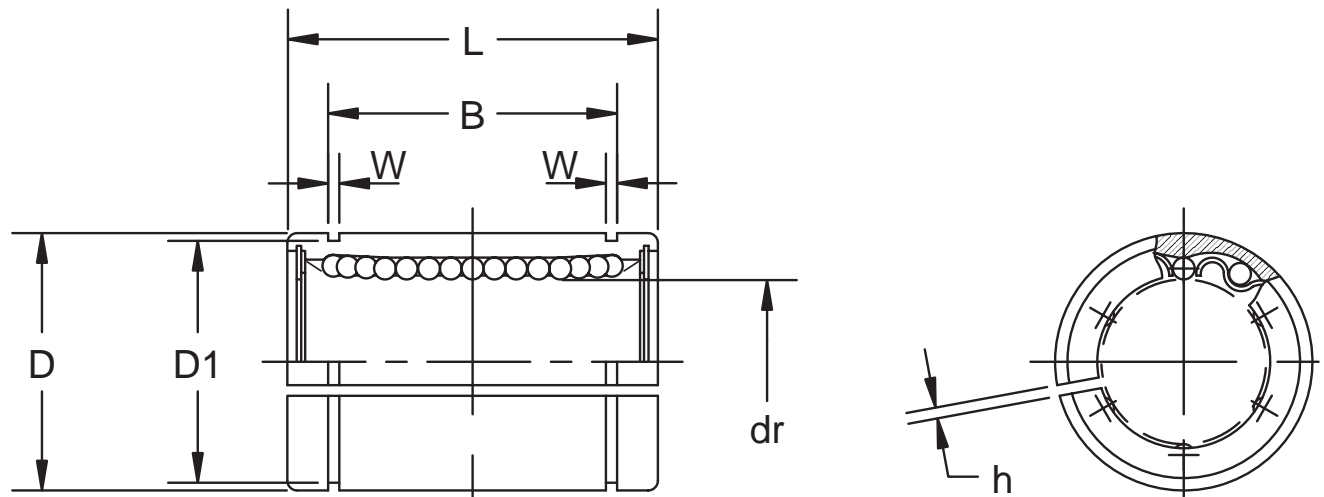

Major dimensions						h	eccentricity	Radial clearance (maximum)	Basic load rating		mass	shaft diameter
L		B		W	D ₁				dynamic	static		
inch	tolerance	inch	tolerance									
mm	inch/mm	mm	inch/mm	mm	mm	C	Co	g	inch			
				mm	mm	lbs	lbs		mm			
.7500		.5100		.0390	.4687	.04						
19.050		12.98		0.992	11.906	1	.0005	-.0001	46	60	7.5	1/4
.8750		.6358		.0390	.5880	.04	12	-3	50	70	13.5	3/8
22.225	0	12.15	0	0.992	14.935	1						9.525
1.2500	-.008	.9625	-.008	.0459	.8209	.06			114	176	41	1/2
31.750	0	24.46	0	1.168	20.853	1.5	.0005	-.0001	173	265	83	12.700
1.5000	-.02	1.1039	-.02	.0559	1.0590	.06	12	-4	193	307	102	5/8
38.100		28.04		1.422	26.899	1.5			220	352	218	15.875
1.6250		1.1657		.0559	1.1760	.06			352	615	455	3/4
41.275		29.61		1.422	29.870	1.5	.0006	-.0002	490	903	710	19.050
2.2500		1.7547		.0679	1.4687	.06	15	-6	858	1,784	1,290	1
57.150		44.57		1.727	37.306	1.5						25.400
2.6250		2.0047		.0679	1.8859	.10						1-1/4
66.675	0	50.92	0	1.727	47.904	2.5	.0008	-.0003				31.750
3.0000	-.012	2.4118	-.012	0.859	2.2389	.12	20	-8				1-1/2
76.200	0	61.26	0	2.184	56.870	3						38.100
4.0000	-.03	3.1917	-.03	.1029	2.8379	.12	.0010	-.0005				2
101.600		81.07		2.616	72.085	3	25	-13				50.800

1kg=2.205lbs

LBXT Type

Open Type

This type is an inch dimension series mainly used in the U.S.

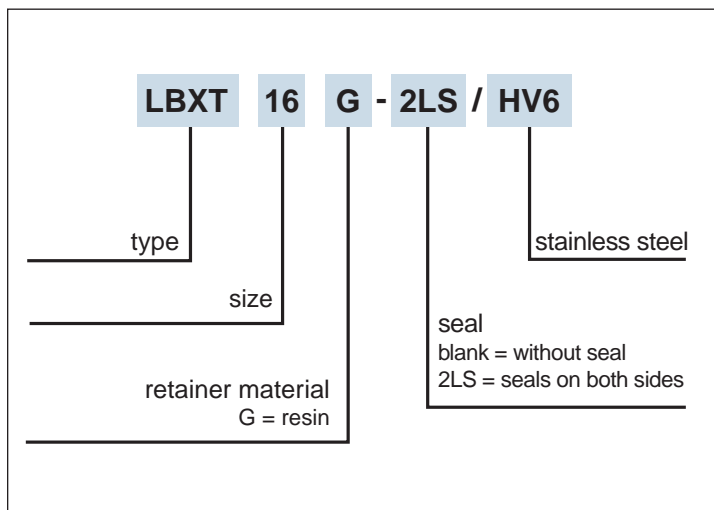

Part Number		Number of ball circuits	dr		D	
Standard	Stainless Steel		inch mm	tolerance inch/ μ m	inch mm	tolerance inch/ μ m
Resin retainer	Resin retainer					
LBXT8G	LBXT8G/HV6	3	.5000	0	.8750	0
			12.700	-.00040	22.225	-.00050
LBXT10G	LBXT10G/HV6	3	.625	0	1.1250	0
			15.875	-9	28.575	-13
LBXT12G	LBXT12G/HV6	4	.7500	0	1.2500	0
			19.050	-.00040	31.750	-.00065
LBXT16G	LBXT16G/HV6	5	1.0000	0	1.5625	0
			25.400	-10	39.688	-16
LBXT20G	LBXT20G/HV6	5	1.2500	0	2.0000	0
			31.750	0	50.800	-.00075
LBXT24G	LBXT24G/HV6	5	1.5000	-.00050	2.3750	0
			38.100	0	60.325	-19
LBXT32G	LBXT32G/HV6	5	2.0000	-12	3.0000	0
			50.800		76.200	-.00090
						0
						-22

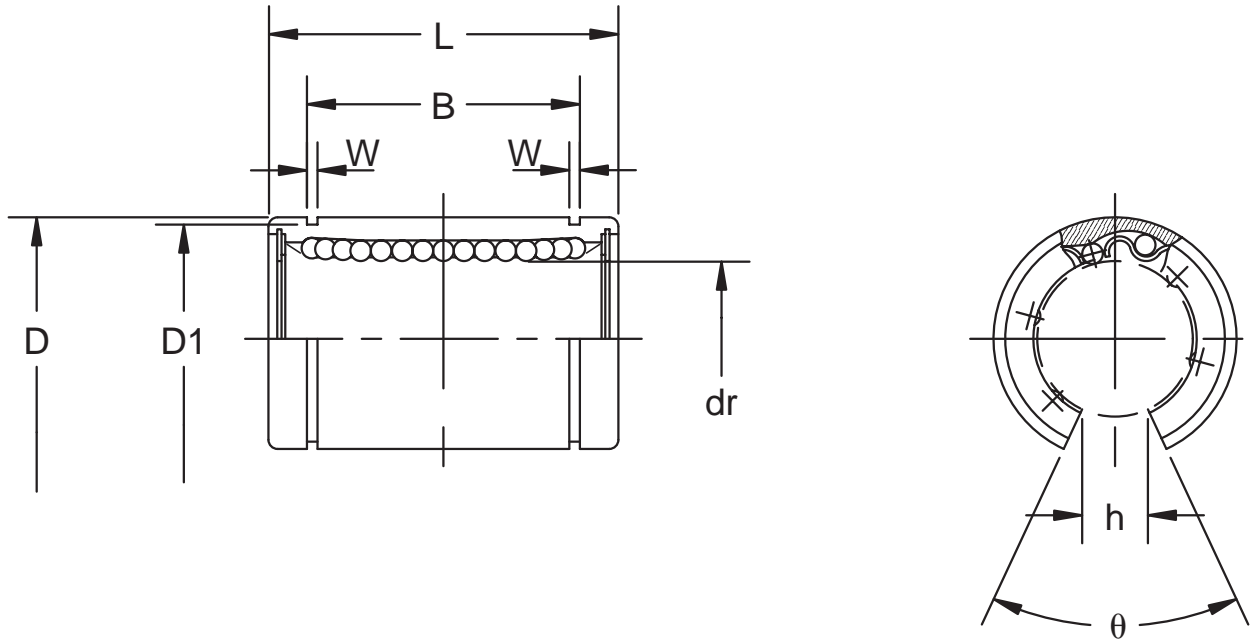

Major dimensions								eccentricity*	Radial clearance (maximum)	Basic load rating		mass	shaft diameter
L		B		W	D ₁	h	θ			dynamic	static		
inch	tolerance inch/mm	inch	tolerance inch/mm	inch	mm	mm	mm	inch	inch/ μ m	C lbs	C ₀ lbs		mm
1.2500	0	.9625	0	.0459	.8209	.34	80°	.0005	-0.0001	114	176	32	1/2
31.750	-0.008	24.46	-0.008	1.168	20.853	7.9375							
1.5000	0	1.1039	0	.0559	1.0590	.375	80°	12	-4	173	265	64	5/8
38.100	-0.2	28.04	-0.2	1.422	26.899	9.5250							15.875
1.6250		1.1657		.0559	1.1760	.4375	60°	.0006	-0.0002	193	307	86	3/4
41.275		29.61		1.422	29.870	11.1125							
2.2500		1.7547		.0679	1.4687	.5625	50°	15	-6	220	352	190	1
57.150	0	44.57	0	1.727	37.306	14.2875							25.400
2.6250	-0.12	2.0047	-0.12	.0679	1.8859	.625	50°	.0008	-0.0003	352	615	390	1-1/4
66.675	0	50.92	0	1.727	47.904	15.875							
3.0000	-0.3	2.4118	-0.3	0.859	2.2389	.75	50°	20	-8	490	903	610	1-1/2
76.200		61.26		2.184	56.870	19.05							38.100
4.0000		3.1917		.1029	2.8379	1.0	50°	.0010	-0.0005	858	1,784	1,120	2
101.600		81.07		2.616	72.085	25.40		25	-13				50.800

* Accuracy is measured prior to machining clearance slot.

1kg=2.205lbs

LBXD/LBXF Type

Self-Aligning Inch Type

This type is an inch dimension series mainly used in the U.S.

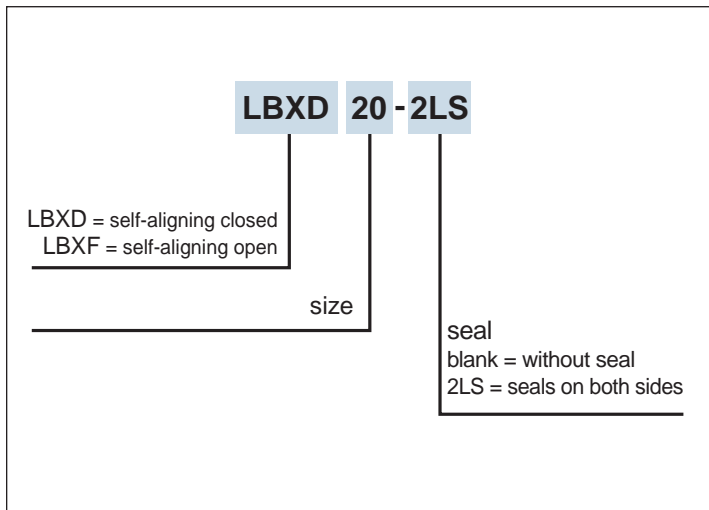

Part Number						Major dimensions				
Closed type			Open type			dr		D	L	
No. of ball Circuits	mass lbs		No. of ball circuits	mass lbs	inch	tolerance* inch	inch		tolerance inch	
LBXD3	4	.004	-	-	-	.1875	0 -.0005	.3750	.562	±.008
LBXD4	4	.009	-	-	-	.2500		.5000	.750	0
LBXD6	4	.014	-	-	-	.3750		.6250	.875	-.015
LBXD8	4	.043	LBXF8	3	.033	.5000		.8750	1.250	0 -.020
LBXD10	5	.103	LBXF10	4	.083	.6250		1.1250	1.500	
LBXD12	6	.123	LBXF12	5	.102	.7500		1.2500	1.625	
LBXD16	6	.265	LBXF16	5	.220	1.0000		1.5625	2.250	0 -0/-0.025 0/-0.030 0/-0.040
LBXD20	6	.485	LBXF20	5	.419	1.2500	2.0000	2.625		
LBXD24	6	.750	LBXF24	5	.639	1.5000	2.3750	3.000		
LBXD32	6	1.411	LBXF32	5	1.168	2.0000	0/-0.0008	3.0000	4.000	

*Based on nominal housing bore.

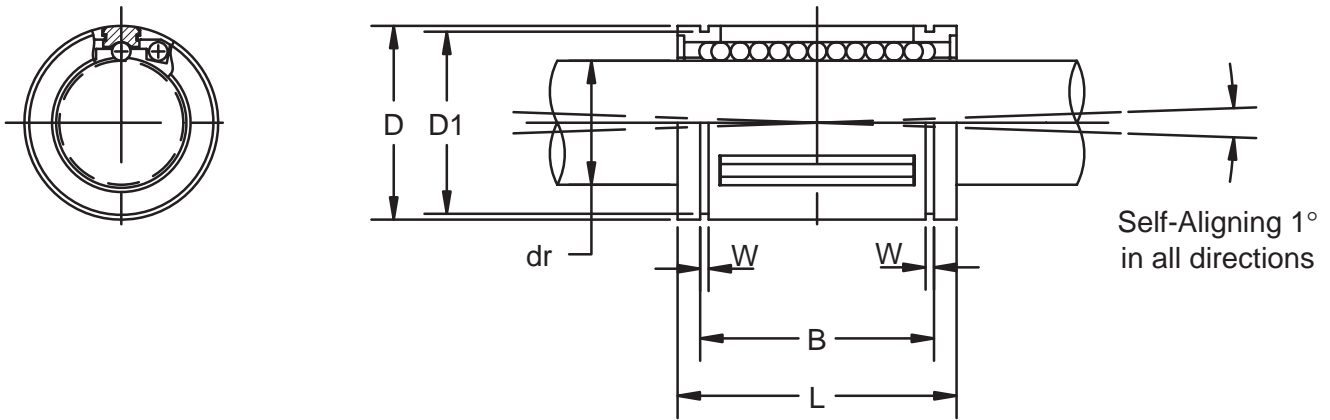

								Basic load rating		Nominal shaft diameter inch	
inch	B	W inch	D1 inch	Open type				Dynamic C lbs	Static Co lbs		
	Tolerance inch			h inch	F inch	G inch	J inch				
-	-	-	-	-	-	-	-	35	47	3/16	
.515	0	.0390	.4687	-	-	-	-	60	80	1/4	
.703	-.015	.0390	.5880	-	-	-	-	95	120	3/8	
1.032	0	.0459	.8209	.313	.136	.6250	through	230	290	1/2	
1.112		.0559	1.0590	.375	.105	.1250	.0390	400	500	5/8	
1.272		-.020	.0559	1.1760	.438	.136	.1250	.0590	470	590	3/4
1.886		.0679	1.4687	.563	.136	.1250	.0470	850	1,060	1	
2.011	0/- .025	.0679	1.8859	.625	.201	.1875	.0900	1,230	1,530	1-1/4	
2.422	0/- .030	.0859	2.2389	.750	.201	.1875	.0900	1,480	1,850	1-1/2	
3.206	0/- .040	.1029	2.8379	1.000	.265	.3125	through	2,430	3,040	2	

1 inch=25.4mm
 1lbs≐0.454kg
 1 lbs≐4.448N

LUXD Type

Block Type

This type is an inch dimension series mainly used in the U.S.

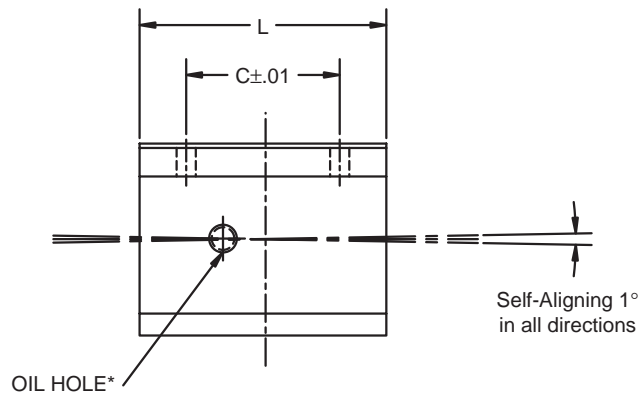
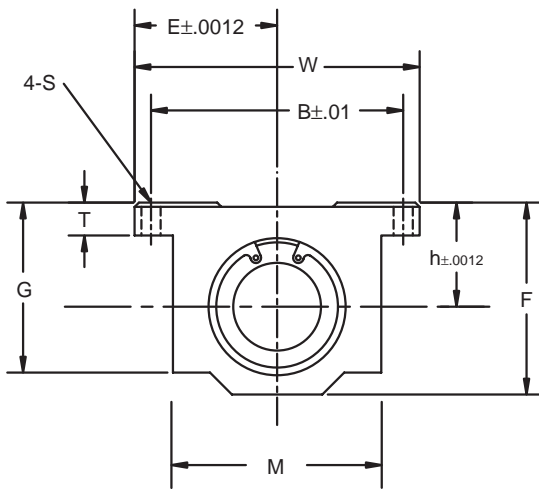
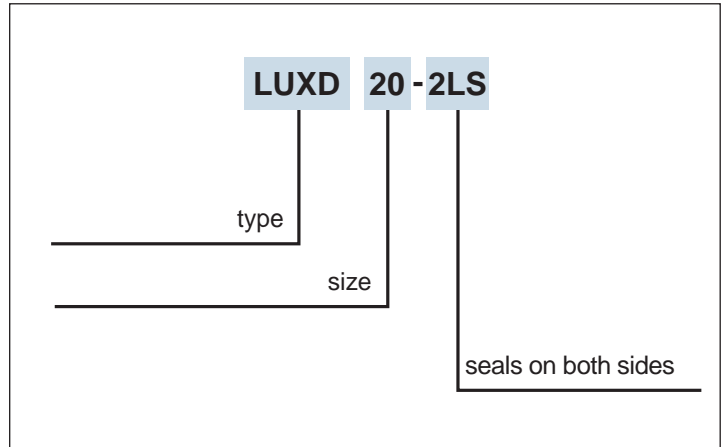
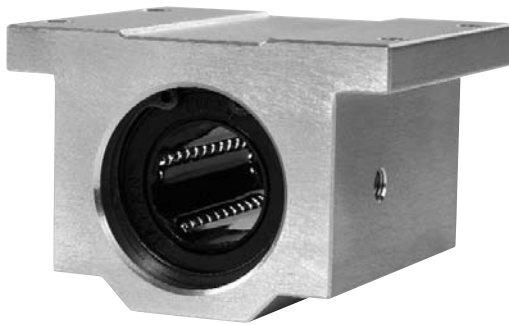

Part Number	Nominal Shaft diameter inch	Major dimensions								Mounting dimensions			Basic load rating		mass lbs.
		h	E	W	L	F	T	G	M	B	C	S	C	Co	
		inch	inch	inch	inch	inch	inch	inch	inch	inch	inch	inch	lbs.	lbs.	
LUXD4-2LS	1/4	.4370	.8125	1.625	1.188	.813	.188	.750	1.000	1.312	.750	.156	60	80	.090
LUXD6-2LS	3/8	.5000	.8750	1.750	1.313	.938	.188	.875	1.125	1.437	.875	.156	95	120	.120
LUXD8-2LS	1/2	.6870	1.0000	2.000	1.688	1.250	.250	1.125	1.375	1.688	1.000	.156	230	290	.248
LUXD10-2LS	5/8	.8750	1.2500	2.500	1.938	1.625	.281	1.437	1.750	2.125	1.125	.188	400	500	.465
LUXD12-2LS	3/4	.9370	1.3750	2.750	2.063	1.750	.313	1.563	1.875	2.375	1.250	.188	470	590	.553
LUXD16-2LS	1	1.1870	1.6250	3.250	2.813	2.188	.375	1.938	2.375	2.875	1.750	.219	850	1060	1.200
LUXD20-2LS	1-1/4	1.5000	2.0000	4.000	3.625	2.813	.438	2.500	3.000	3.500	2.000	.219	1230	1530	2.380
LUXD24-2LS	1-1/2	1.7500	2.3750	4.750	4.000	3.250	.500	2.875	3.500	4.125	2.500	.281	1480	1850	3.460
LUXD32-2LS	2	2.1250	3.0000	6.000	5.000	4.063	.625	3.625	4.500	5.250	3.250	.406	2430	3040	6.830

* Provided with push-in oil fitting for 1/4" to 1/2" sizes. Sizes from 5/8" to 2" offer a 1/4-28 tapped hole with a plug for adding a fitting if desired.

1 inch=25.4mm

1lbs=0.454kg

1 lbs=4.448N

Clearance Adjustable Block Type

This type is an inch dimension series mainly used in the U.S.

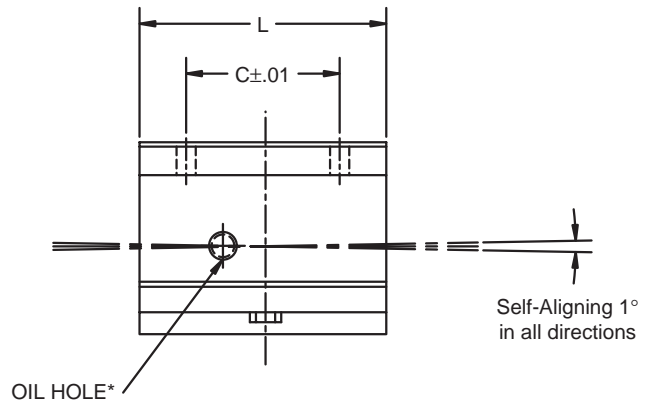
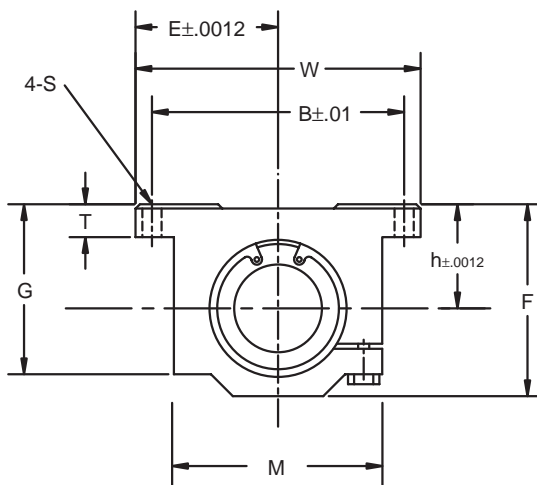
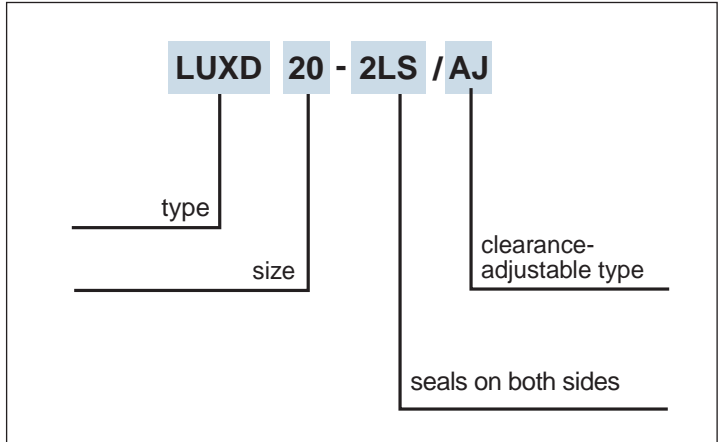

Part Number	Nominal Shaft diameter	Major dimensions								Mounting dimensions			Basic load rating		
		h	E	W	L	F	T	G	M	B	C	S	dynamic	static	mass
		inch	inch	inch	inch	inch	inch	inch	inch	inch	inch	inch	lbs.	lbs.	lbs.
LUXD4-2LS/AJ	1/4	.4370	.8125	1.625	1.188	.813	.188	.750	1.000	1.312	.750	.156	60	80	.090
LUXD6-2LS/AJ	3/8	.5000	.8750	1.750	1.313	.938	.188	.875	1.125	1.437	.875	.156	95	120	.120
LUXD8-2LS/AJ	1/2	.6870	1.0000	2.000	1.688	1.250	.250	1.125	1.375	1.688	1.000	.156	230	290	.248
LUXD10-2LS/AJ	5/8	.8750	1.2500	2.500	1.938	1.625	.281	1.437	1.750	2.125	1.125	.188	400	500	.465
LUXD12-2LS/AJ	3/4	.9370	1.3750	2.750	2.063	1.750	.313	1.563	1.875	2.375	1.250	.188	470	590	.553
LUXD16-2LS/AJ	1	1.1870	1.6250	3.250	2.813	2.188	.375	1.938	2.375	2.875	1.750	.219	850	1060	1.200
LUXD20-2LS/AJ	1-1/4	1.5000	2.0000	4.000	3.625	2.813	.438	2.500	3.000	3.500	2.000	.219	1230	1530	2.380
LUXD24-2LS/AJ	1-1/2	1.7500	2.3750	4.750	4.000	3.250	.500	2.875	3.500	4.125	2.500	.281	1480	1850	3.460
LUXD32-2LS/AJ	2	2.1250	3.0000	6.000	5.000	4.063	.625	3.625	4.500	5.250	3.250	.406	2430	3040	6.830

* Provided with push-in oil fitting for 1/4" to 1/2" sizes. Sizes from 5/8" to 2" offer a 1/4-28 tapped hole with a plug for adding a fitting if desired.

1 inch=25.4mm

1 lbs=0.454kg

1 lbs=4.448N

LTXD Type

Tandem Block Type

This type is an inch dimension series mainly used in the U.S.

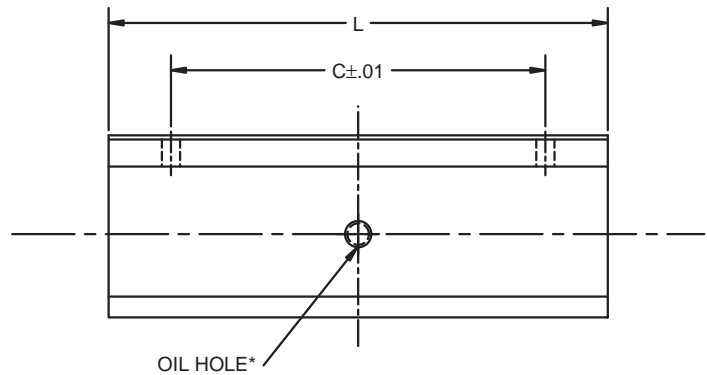
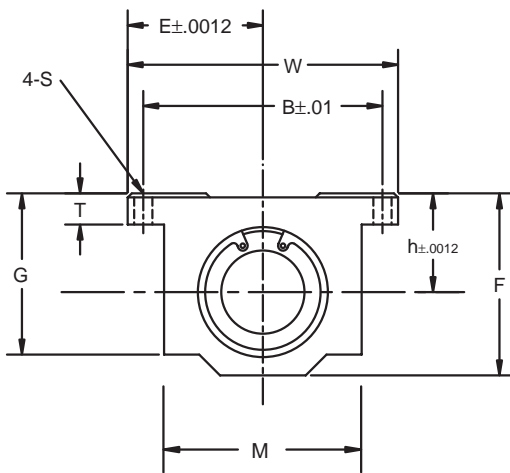
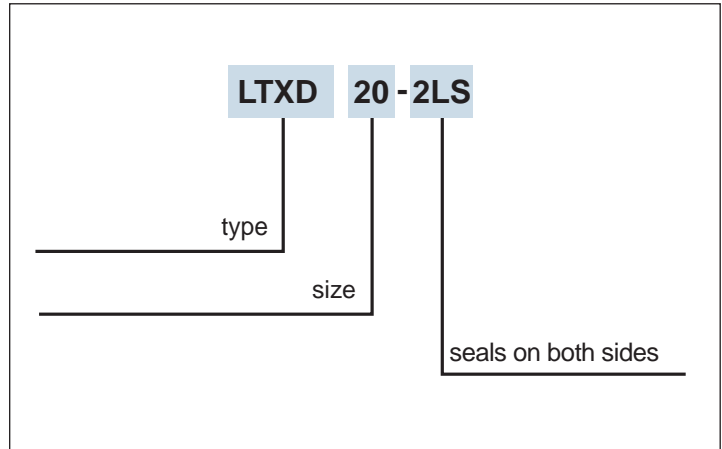

Part Number	Nominal Shaft diameter inch	Major dimensions								Mounting dimensions			Basic load rating		
		h	E	W	L	F	T	G	M	B	C	S	dynamic C	static Co	mass
		inch	inch	inch	inch	inch	inch	inch	inch	inch	inch	inch	lbs.	lbs.	lbs.
LTXD4-2LS	1/4	.4370	.8125	1.625	2.500	.813	.188	.750	1.000	1.312	2.000	.156	96	160	.190
LTXD6-2LS	3/8	.5000	.8750	1.750	2.750	.938	.188	.875	1.125	1.437	2.250	.156	150	240	.250
LTXD8-2LS	1/2	.6870	1.0000	2.000	3.500	1.250	.250	1.125	1.375	1.688	2.500	.156	370	580	.510
LTXD10-2LS	5/8	.8750	1.2500	2.500	4.000	1.625	.281	1.437	1.750	2.125	3.000	.188	640	1000	1.000
LTXD12-2LS	3/4	.9370	1.3750	2.750	4.500	1.750	.313	1.563	1.875	2.375	3.500	.188	750	1180	1.200
LTXD16-2LS	1	1.1870	1.6250	3.250	6.000	2.188	.375	1.938	2.375	2.875	4.500	.219	1360	2120	2.400
LTXD20-2LS	1-1/4	1.5000	2.0000	4.000	7.500	2.813	.438	2.500	3.000	3.500	5.500	.219	1970	3060	5.000
LTXD24-2LS	1-1/2	1.7500	2.3750	4.750	9.000	3.250	.500	2.875	3.500	4.125	6.500	.281	2370	3700	7.800

* Provided with push-in oil fitting for 1/4" to 1/2" sizes. Sizes from 5/8" to 2" offer a 1/4-28 tapped hole with a plug for adding a fitting if desired.

1 inch=25.4mm

1lbs≈0.454kg

1 lbs≈4.448N

Clearance Adjustable Tandem Block Type

This type is an inch dimension series mainly used in the U.S.

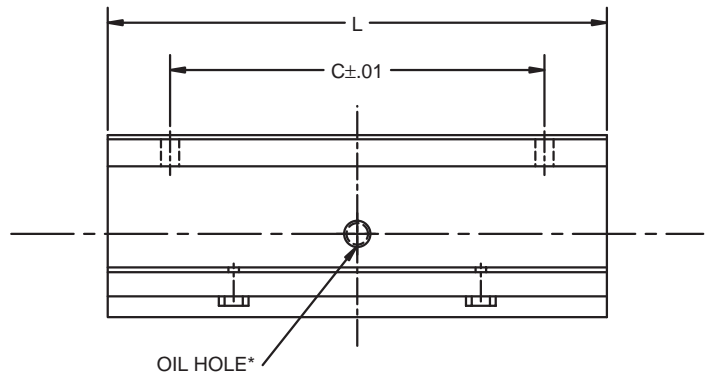
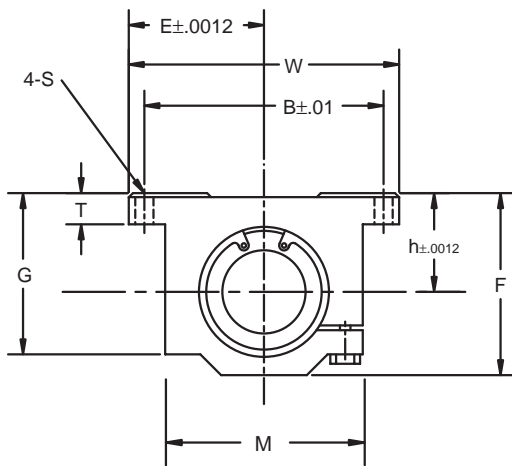
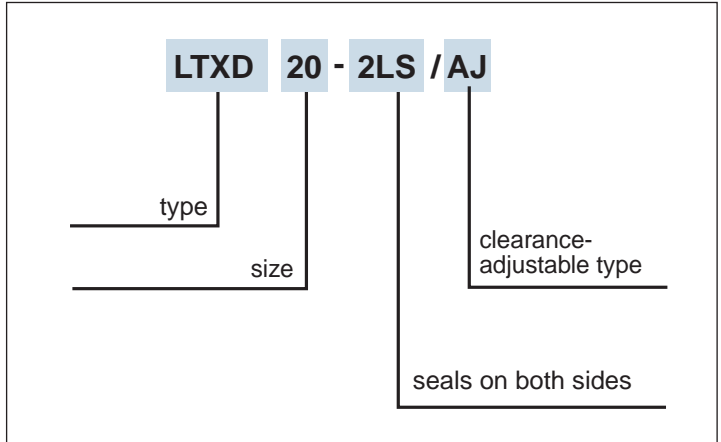

Part Number	Nominal Shaft diameter inch	Major dimensions								Mounting dimensions			Basic load rating		mass lbs.
		h	E	W	L	F	T	G	M	B	C	S	dynamic C	static Co	
		inch	inch	inch	inch	inch	inch	inch	inch	inch	inch	inch	lbs.	lbs.	
LTXD4-2LS/AJ	1/4	.4370	.8125	1.625	2.500	.813	.188	.750	1.000	1.312	2.000	.156	96	160	.190
LTXD6-2LS/AJ	3/8	.5000	.8750	1.750	2.750	.938	.188	.875	1.125	1.437	2.250	.156	150	240	.250
LTXD8-2LS/AJ	1/2	.6870	1.0000	2.000	3.500	1.250	.250	1.125	1.375	1.688	2.500	.156	370	580	.510
LTXD10-2LS/AJ	5/8	.8750	1.2500	2.500	4.000	1.625	.281	1.437	1.750	2.125	3.000	.188	640	1000	1.000
LTXD12-2LS/AJ	3/4	.9370	1.3750	2.750	4.500	1.750	.313	1.563	1.875	2.375	3.500	.188	750	1180	1.200
LTXD16-2LS/AJ	1	1.1870	1.6250	3.250	6.000	2.188	.375	1.938	2.375	2.875	4.500	.219	1360	2120	2.400
LTXD20-2LS/AJ	1-1/4	1.5000	2.0000	4.000	7.500	2.813	.438	2.500	3.000	3.500	5.500	.219	1970	3060	5.000
LTXD24-2LS/AJ	1-1/2	1.7500	2.3750	4.750	9.000	3.250	.500	2.875	3.500	4.125	6.500	.281	2370	3700	7.800

* Provided with push-in oil fitting for 1/4" to 1/2" sizes. Sizes from 5/8" to 2" offer a 1/4-28 tapped hole with a plug for adding a fitting if desired.

1 inch=25.4mm

1lbs=0.454kg

1 lbs=4.448N

LUXF Type

Open Block Type

This type is an inch dimension series mainly used in the U.S.

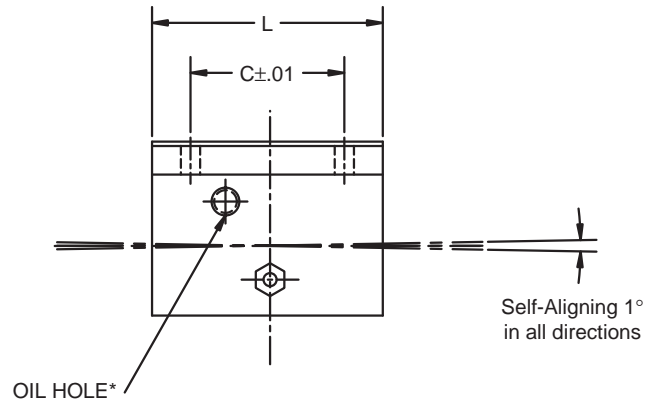
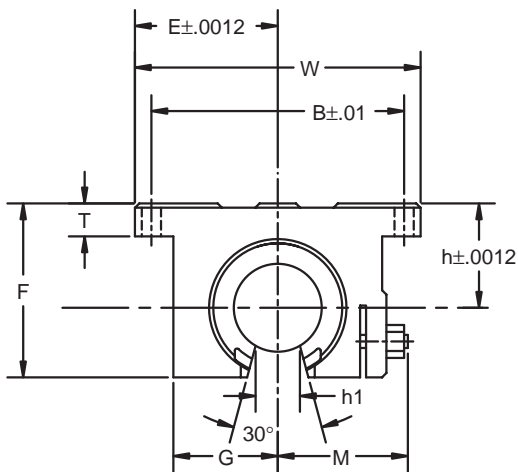
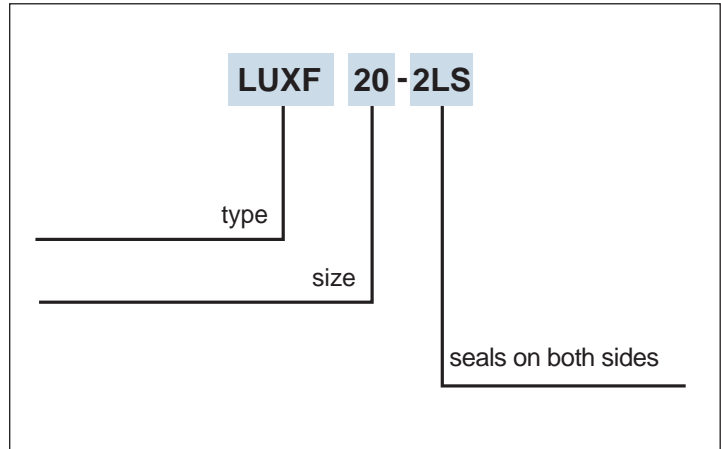
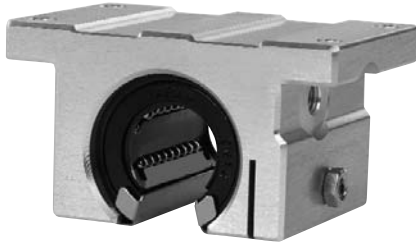

Part Number	Nominal Shaft diameter inch	Major dimensions									Mounting dimensions			Basic load rating		mass lbs.
		h	E	W	L	F	T	G	M	h ₁	B	C	S	C	Co	
		inch	inch	inch	inch	inch	inch	inch	inch	inch	inch	inch	inch	lbs.	lbs.	
LUXF8-2LS	1/2	.6870	1.000	2.000	1.500	1.100	.250	.688	.98	.260	1.688	1.000	.156	230	290	.188
LUXF10-2LS	5/8	.8750	1.2500	2.500	1.750	1.405	.281	.875	1.15	.319	2.125	1.125	.188	400	500	.365
LUXF12-2LS	3/4	.9370	1.3750	2.750	1.875	1.535	.315	.937	1.23	.386	2.375	1.250	.188	470	590	.452
LUXF16-2LS	1	1.1870	1.6250	3.250	2.625	1.975	.375	1.188	1.48	.512	2.875	1.750	.218	850	1060	1.010
LUXF20-2LS	1-1/4	1.5000	2.0000	4.000	3.375	2.485	.437	1.500	1.88	.569	3.500	2.000	.218	1230	1530	1.980
LUXF24-2LS	1-1/2	1.7500	2.3750	4.750	3.750	2.910	.500	1.750	2.12	.681	4.125	2.500	.281	1480	1850	2.950
LUXF32-2LS	2	2.1250	3.0000	6.000	4.750	3.660	.625	2.250	2.70	.933	5.250	3.250	.406	2430	3040	5.840

* Provided with push-in oil fitting for 1/4" to 1/2" sizes. Sizes from 5/8" to 2" offer a 1/4-28 tapped hole with a plug for adding a fitting if desired.

1 inch=25.4mm

1 lbs≈0.454kg

1 lbs≈4.448N

Tandem Open Block Type

This type is an inch dimension series mainly used in the U.S.

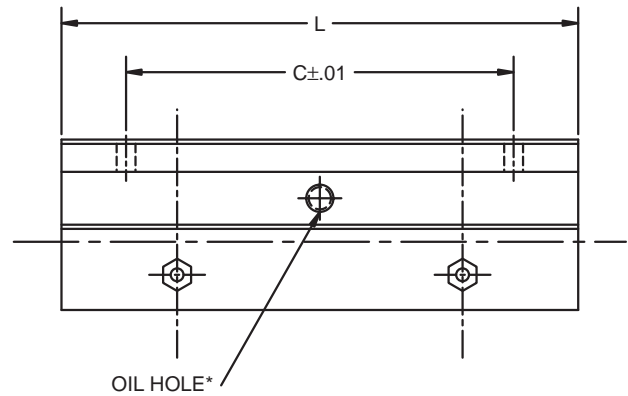
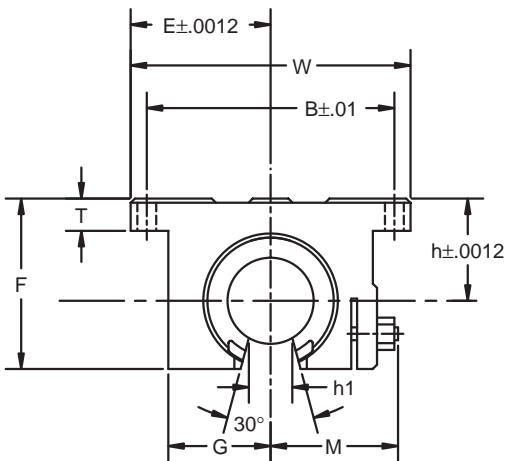
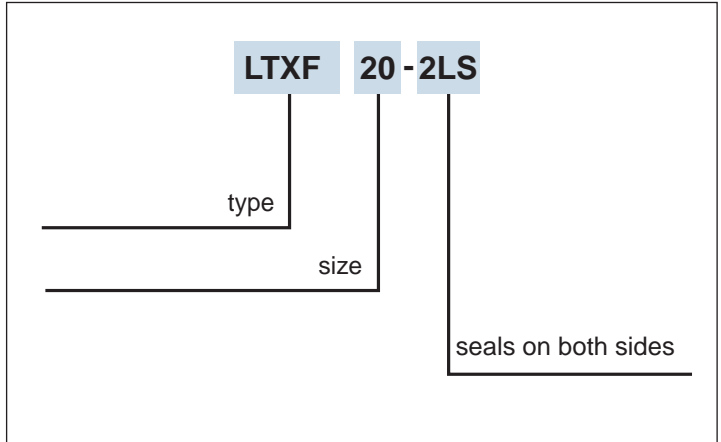

Part Number	Nominal Shaft diameter inch	Major dimensions									Mounting dimensions			Basic load rating		mass lbs.
		h	E	W	L	F	T	G	M	h ₁	B	C	S	C	Co	
		inch	inch	inch	inch	inch	inch	inch	inch	inch	inch	inch	inch	lbs.	lbs.	
LTXF8-2LS	1/2	.6870	1.000	2.000	3.500	1.100	.250	.688	.98	.260	1.688	2.500	.156	370	580	.400
LTXF10-2LS	5/8	.8750	1.2500	2.500	4.000	1.405	.281	.875	1.15	.319	2.125	3.000	.188	640	1000	.800
LTXF12-2LS	3/4	.9370	1.3750	2.750	4.500	1.535	.315	.937	1.23	.386	2.375	3.500	.188	750	1180	1.000
LTXF16-2LS	1	1.1870	1.6250	3.250	6.000	1.975	.375	1.188	1.48	.512	2.875	4.500	.218	1360	2120	2.000
LTXF20-2LS	1-1/4	1.5000	2.0000	4.000	7.500	2.485	.437	1.500	1.88	.569	3.500	5.500	.218	1970	3060	4.200
LTXF24-2LS	1-1/2	1.7500	2.3750	4.750	9.000	2.910	.500	1.750	2.12	.681	4.125	6.500	.281	2370	3700	6.700

* Provided with push-in oil fitting for 1/4" to 1/2" sizes. Sizes from 5/8" to 2" offer a 1/4-28 tapped hole with a plug for adding a fitting if desired.

1 inch=25.4mm

1lbs=0.454kg

1 lbs=4.448N

Interchange

SKF Designation	THOMSON Designation
Inch Standard	
LBXR 4 or LBXR 4 G	A-4812
LBXR 6 or LBXR 6 G	A-61014
LBXR 8 or LBXR 8 G	A-81420
LBXR 10 or LBXR 10 G	A-101824
LBXR 12 or LBXR 12 G	A-122026
LBXR 16 or LBXR 16 G	A-162536
LBXR 20 or LBXR 20 G	A-203242
LBXR 24 or LBXR 24 G	A-243848
LBXR 32 or LBXR 32 G	A-324864
LBXR 40	A-406080
LBXR 48	A-487296
LBXR 64	A-6496128

Adjustable Type	
LBXR 8 G/AJ	ADJ-81420
LBXR 10 G/AJ	ADJ-101824
LBXR 12 G/AJ	ADJ-122026
LBXR 16 G/AJ	ADJ-162536
LBXR 20 G/AJ	ADJ-203242
LBXR 24 G/AJ	ADJ-243848
LBXR 32 G/AJ	ADJ-324864

Open Type	
LBXT 8 G	OPN-81420
LBXT 10 G	OPN-101824
LBXT 12 G	OPN-122026
LBXT 16 G	OPN-162536
LBXT 20 G	OPN-203242
LBXT 24 G	OPN-243848
LBXT 32 G	OPN-324864

Self Aligning Type Closed Type	
LBXD 4	SUPER-4
LBXD 6	SUPER-6
LBXD 8	SUPER-8
LBXD 10	SUPER-10
LBXD 12	SUPER-12
LBXD 16	SUPER-16
LBXD 20	SUPER-20
LBXD 24	SUPER-24
LBXD 32	SUPER-32

SKF Designation	THOMSON Designation
Open Type	
LBXF 8	SUPER-8-OPN
LBXF 10	SUPER-10-OPN
LBXF 12	SUPER-12-OPN
LBXF 16	SUPER-16-OPN
LBXF 20	SUPER-20-OPN
LBXF 24	SUPER-24-OPN
LBXF 32	SUPER-32-OPN
LBXF 8-2LS	SUPER-8-OPN-DD
LBXF 10-2LS	SUPER-10-OPN-DD
LBXF 12-2LS	SUPER-12-OPN-DD
LBXF 16-2LS	SUPER-16-OPN-DD

Stainless Steel Type with Resin Retainer Closed Type	
LBXR 4 G/HV6	A-4812-SS
LBXR 6 G/HV6	A-61014-SS
LBXR 8 G/HV6	A-81420-SS
LBXR 10 G/HV6	A-101824-SS
LBXR 12 G/HV6	A-122026-SS
LBXR 16 G/HV6	A-162536-SS

Adjustable Type	
LBXR 8 G/AJHV6	ADJ-81420-SS
LBXR 10 G/AJHV6	ADJ-101824-SS
LBXR 12 G/AJHV6	ADJ-122026-SS
LBXR 16 G/AJHV6	ADJ-162536-SS

Open Type	
LBXT 8 G/HV6	OPN-81420-SS
LBXT 10 G/HV6	OPN-101824-SS
LBXT 12 G/HV6	OPN-122026-SS
LBXT 16 G/HV6	OPN-162536-SS

Inch Series Self Aligning Units Block Type	
LUXD 4-2LS	SPB-4
LUXD 6-2LS	SPB-6
LUXD 8-2LS	SPB-8
LUXD 10-2LS	SPB-10
LUXD 12-2LS	SPB-12
LUXD 16-2LS	SPB-16
LUXD 20-2LS	SPB-20
LUXD 24-2LS	SPB-24
LUXD 32-2LS	SPB-32

SKF Designation	THOMSON Designation
Adjustable Type	
LUXD 4-2LS/AJ	SPB-4-ADJ
LUXD 6-2LS/AJ	SPB-6-ADJ
LUXD 8-2LS/AJ	SPB-8-ADJ
LUXD 10-2LS/AJ	SPB-10-ADJ
LUXD 12-2LS/AJ	SPB-12-ADJ
LUXD 16-2LS/AJ	SPB-16-ADJ
LUXD 20-2LS/AJ	SPB-20-ADJ
LUXD 24-2LS/AJ	SPB-24-ADJ
LUXD 32-2LS/AJ	SPB-32-ADJ

Open Type	
LUXF 8-2LS	SPB-8-OPN
LUXF 10-2LS	SPB-10-OPN
LUXF 12-2LS	SPB-12-OPN
LUXF 16-2LS	SPB-16-OPN
LUXF 20-2LS	SPB-20-OPN
LUXF 24-2LS	SPB-24-OPN
LUXF 32-2LS	SPB-32-OPN

Inch Series Self Aligning Double Wide Units Block Type	
LTXD 4-2LS	TWN-4
LTXD 6-2LS	TWN-6
LTXD 8-2LS	TWN-8
LTXD 10-2LS	TWN-10
LTXD 12-2LS	TWN-12
LTXD 16-2LS	TWN-16
LTXD 20-2LS	TWN-20
LTXD 24-2LS	TWN-24

Adjustable Type	
LTXD 4-2LS/AJ	TWN-4-ADJ
LTXD 6-2LS/AJ	TWN-6-ADJ
LTXD 8-2LS/AJ	TWN-8-ADJ
LTXD 10-2LS/AJ	TWN-10-ADJ
LTXD 12-2LS/AJ	TWN-12-ADJ
LTXD 16-2LS/AJ	TWN-16-ADJ
LTXD 20-2LS/AJ	TWN-20-ADJ
LTXD 24-2LS/AJ	TWN-24-ADJ

Open Type	
LTXF 8-2LS	TWN-8-OPN
LTXF 10-2LS	TWN-10-OPN
LTXF 12-2LS	TWN-12-OPN
LTXF 16-2LS	TWN-16-OPN
LTXF 20-2LS	TWN-20-OPN
LTXF 24-2LS	TWN-24-OPN

*Notes:

1) All the linear bearings are available with 2 integral seals.

2) Not all the linear bearings we offer are shown in this table. Please check catalog for all available sizes/options.



SKF Linear Motion

1530 Valley Center Parkway
Bethlehem, PA 18017-2266
800-541-3624
Fax 610-861-4811
www.linearmotion.skf.com