

SKF

SKF Sensor-Bearing Units - concentrate intelligence in your motion control



Contents

Made by SKF® stands for excellence. It symbolises our consistent endeavour to achieve total quality in everything we do. For those who use our products. “Made by SKF” implies three main benefits.

Reliability – thanks to modern, efficient products, based on our worldwide application know-how, optimised materials, forward-looking designs and the most advanced production techniques.

Cost effectiveness – resulting from the favourable ratio between our product quality plus service facilities, and the purchase price of the product.

Market lead – which you can achieve by taking advantage of our products and services. Increased operating time and reduced down-time, as well as improved output and product quality are the key to a successful partnership.



1 Product information..... 3

Ball bearing + Sensor = Sensor-Bearing Unit 3

| | |
|--|---|
| What is an SKF Sensor-Bearing Unit and how does it work? | 4 |
| Why SKF Sensor-Bearing Unit? | 4 |
| This is the answer..... | 6 |
| Small, yet great..... | 6 |
| Electro-magnetic compatibility | 7 |
| When quality and reliability count..... | 8 |

2 Recommendations 12

Application of units 12

| | |
|-----------------------------------|----|
| Selection of bearing size | 12 |
| Unit arrangement | 12 |
| Electrical interface data | 14 |
| Mounting | 14 |
| Lubrication and maintenance | 15 |

3 Product data..... 16

| | |
|-------------------------|----|
| General unit data | 16 |
| Product table..... | 18 |

Other SKF bearing units 20

The SKF Group – a worldwide organisation..... 22

Design features

Page12

Page16

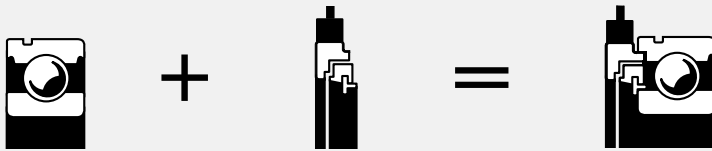

Clear information on the status of travelling machine parts is decisive in many fields of engineering so as to enable reliable open-loop and closed-loop control of movements. Such information becomes all the more important with the increasing necessity of creating more light-weight and simpler constructions.

Basically, everything started with the implementation of anti-lock braking systems (ABS) in vehicles. "Intelligent bearings" were required to record the variations of the circumferential speed of the wheel. From the very beginning SKF was involved in the development and subsequent improvement of these bearings. Millions of these intelligent bearings have been supplied by SKF and operate reliably worldwide.

Compared with the initial concept of separate components, the integration of sensor, impulse ring and bearing, which was mainly driven by SKF efforts, was an important step towards higher quality in signal generation and transmission, more compact construction and simpler design.

Bearings with integral sensors are no longer used only in vehicles, but have spread to many other fields of application. These are in the first place SKF Sensor-Bearing Units used for recording

- the number of revolutions
- the speed
- the direction of rotation
- the relative position/counting
- acceleration or deceleration



Number of revolutions



Speed



Direction of rotation



Relative position counting

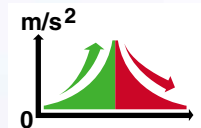

Acceleration or deceleration



What is an SKF Sensor-Bearing Unit ...

SKF Sensor-Bearing Units are mecha-tronic machine components covering the fields of both sensor and bearing engineering. They are virtually an ideal combination of versatile deep groove ball bearings with sensor units shielded from external influences. Sensor body, impulse ring and bearing are mechanically attached to each other, forming an integral ready-to-mount unit.

The output from the sensor is two square pulse signals with a 90° phase difference which allow determination of the direction of rotation

... and how does it work?

A magnetic impulse ring divided into a sequence of north and south poles is attached to the inner ring of the SKF Sensor-Bearing Unit. The outer ring carries a sensor body with embedded Hall cells.

When the inner ring rotates, the impulse ring moves past the stationary sensor ring, generating a magnetic field of changing polarity. The sensor outputs a pulse the frequency of which depends on the number of polarity changes per second. Via the sensor bearing connection cable, the sensor output signal is transmitted to an electronic unit normally developed by the user. This unit evaluates the signal and provides application-specific information.

The sensor body contains two cells, the two output signals offset in phase allowing determination of the direction of rotation (→ fig 1).

Why SKF Sensor-Bearing Unit?

Since the beginning of the 1980s SKF has been intensively involved in sensorised bearings and has had a decisive influence on their development. Today SKF Sensor-Bearing Units are technically advanced products which have proved their superiority over other solutions time and time again. Our Sensor-Bearing Units are based on this wealth of application-specific knowledge gathered over the past twenty years – yet another example of our expertise to your benefit. In fact SKF Sensor-Bearing Units offer significant total cost reduction on both

- existing solutions, due to less need for adaptation
- new projects, due to simpler and more compact design.

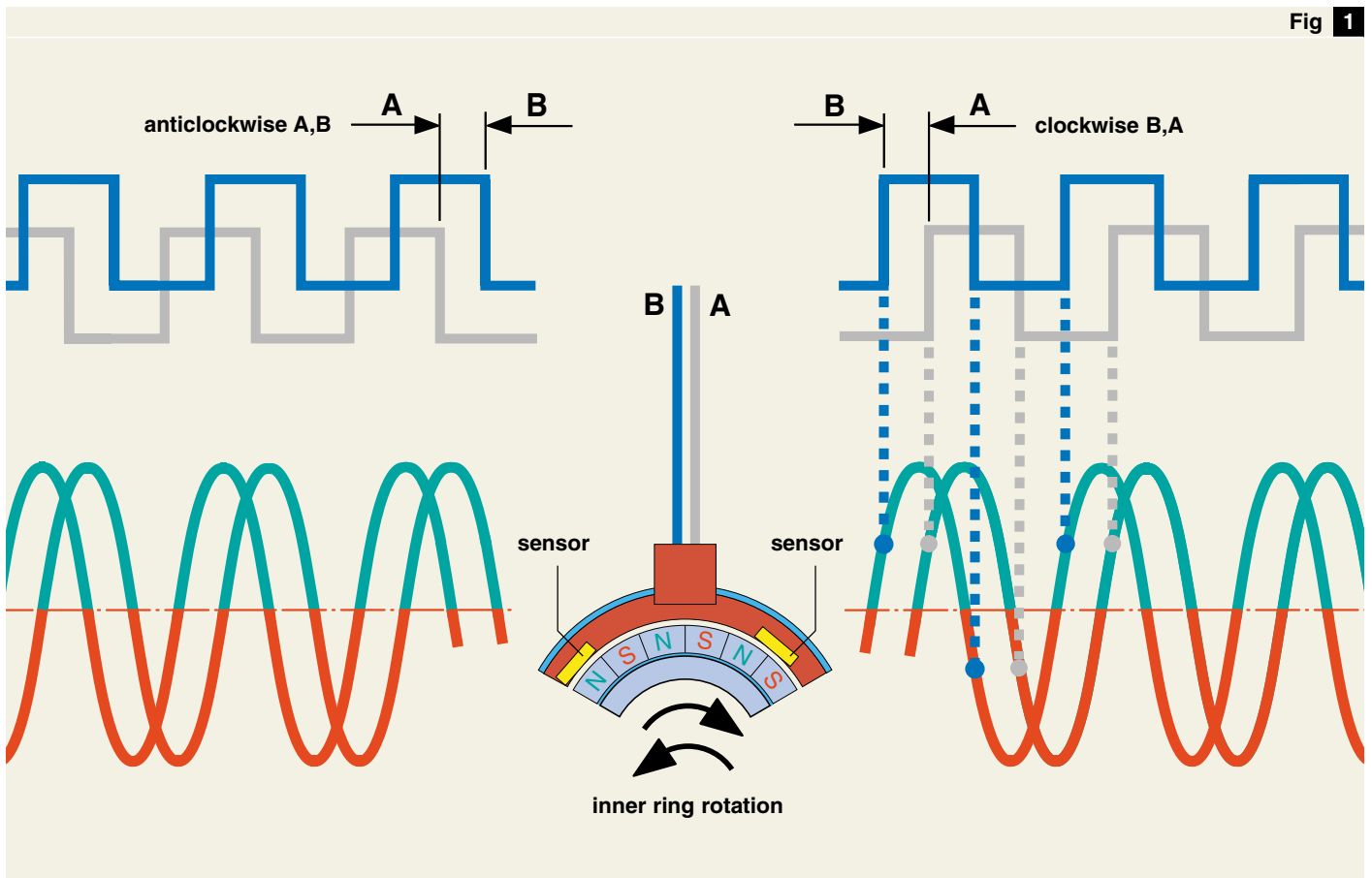

Design features

The SKF designed and patented Sensor-Bearing Unit is a simple, robust and compact mechatronic machine element – a combination of proven, high quality mechanics and advanced sensor technology. It consists of

- an SKF deep groove ball bearing with one seal and
- an SKF active sensor, consisting of impulse ring and sensor body as well as a connecting cable capable of measuring even zero movement.

The SKF deep groove ball bearing

The single row SKF deep groove ball bearings are suitable for high speeds, robust in operation and do not require any maintenance. They can accommodate not only rather high radial loads, but also axial loads and serve as locating bearings guiding the shaft axially in both directions. Furthermore they are noted for their high manufacturing accuracy, their low noise and friction levels, the efficient sealing and the grease filling ensuring maintenance-free operation for life.

The SKF active sensor unit

The SKF Sensor-Bearing Unit incorporates an active sensor designed to be compact and robust, very close to an incremental encoder function. It provides accurate measuring down to zero speed. Its main components are the impulse ring, the sensor body with the sensors and the connecting cable.

The composite magnetised impulse ring is attached to the bearing inner ring. Depending on the bearing size, it is divided into a certain number of north and south poles. The number of pulses per revolution normally ranges between 32 and 80.

Page12

The sensor body is attached to the bearing outer ring by an SKF patented solution. The sensor body has two cells, enabling the direction of rotation to be determined. The two sensors are offset to each other in the sensor body. In a small integrated circuit they contain not only the Hall generator as an active element but also the electronics for signal amplification and conversion. The analogue sinusoidal signal generated by the Hall generator is amplified and converted into a square-wave signal by a Schmitt trigger.

The sensors require an external voltage supply.

SKF guarantees the signals, 100 % checked at the manufacturing process level.

Their output signals are in phase quadrature, the leading signal depending on the direction of rotation. Furthermore two sensors enable double the number of pulses. Instead of 64 pulses per revolution in a standard bearing there are now 128 pulses per revolution. When counting the rising and falling edges of the pulses a maximum accuracy of 256 pulses per revolution can be attained, which corresponds to a resolution of 1,4 angular degrees.

The signal output is fed via an open collector circuit. Speeds down to zero can be recorded.

The SKF Sensor-Bearing Unit is suitable for operating temperatures of up to +120 °C.

Page16

Proven quality

SKF Sensor-Bearing Unit – a construction of proven, high quality mechanics and advanced sensor technology

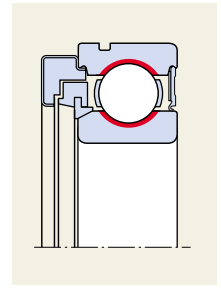
**Axial location**

The bearing provides radial loads and locates the shaft axially in both directions

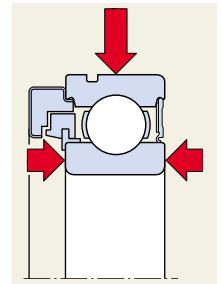
**Well protected**

The bearing has a sheet steel reinforced seal made of wear-resistant nitrile rubber

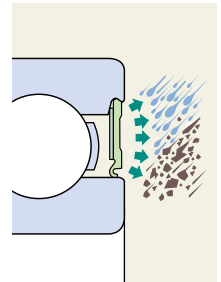

This is the answer

SKF Sensor-Bearing Units are compact, robust, easy-to-mount and cost-saving machine elements for a wide scope of applications in open-loop and closed-loop control engineering. They present a number of significant advantages to the user, as SKF Sensor-Bearing Units

- take up hardly more space than the bearing as such,
- help save weight and total costs,
- require only standard bearing tolerances and normal machining of the adjacent parts,
- simplify considerably the installation since they are ready-to-mount units,
- are lubricated for life and maintenance-free,
- are insensitive to environmental influences and less prone to corrosion,
- do not require time-consuming adjustment or subsequent setting,
- do not require subsequent signal checks,
- provide optimised signal generation and transmission,
- are robust and give output signals of uniform reliability,
- do not suffer from external electromagnetic fields,
- are an attractive alternative compared to an incremental encoder.

Small, yet great

The standard range of SKF Sensor-Bearing Units covers the usual sizes for such applications from 15 to 45 mm bore diameter.

The sensor unit is matched with the rotational speed permissible for the sealed deep groove ball bearing, one of its application scopes being the normal encoder field.

SKF will always strive to give top priority to customer requirements and to develop application-specific and cost-effective solutions in close co-operation with the customer.

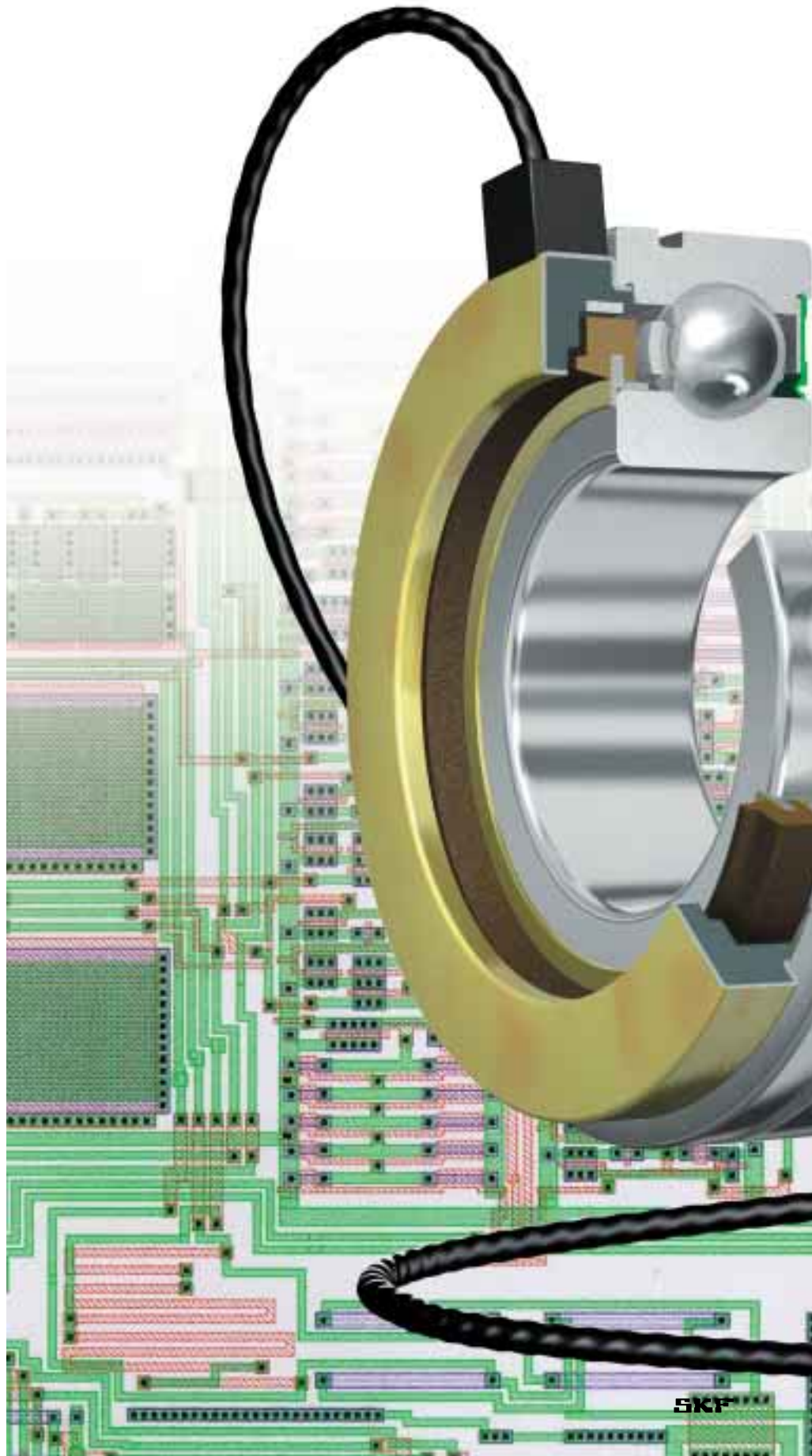

Electro-magnetic compatibility

One decisive factor of satisfactory operation of electronic systems is their ability to operate in difficult industrial environments without interfering with each other.

Thanks to the specific SKF sensor integration, the SKF Sensor-Bearing Units can be used in systems functioning under most arduous electro-magnetic environment such as described in the European Standard EN 50082-2 or similar.

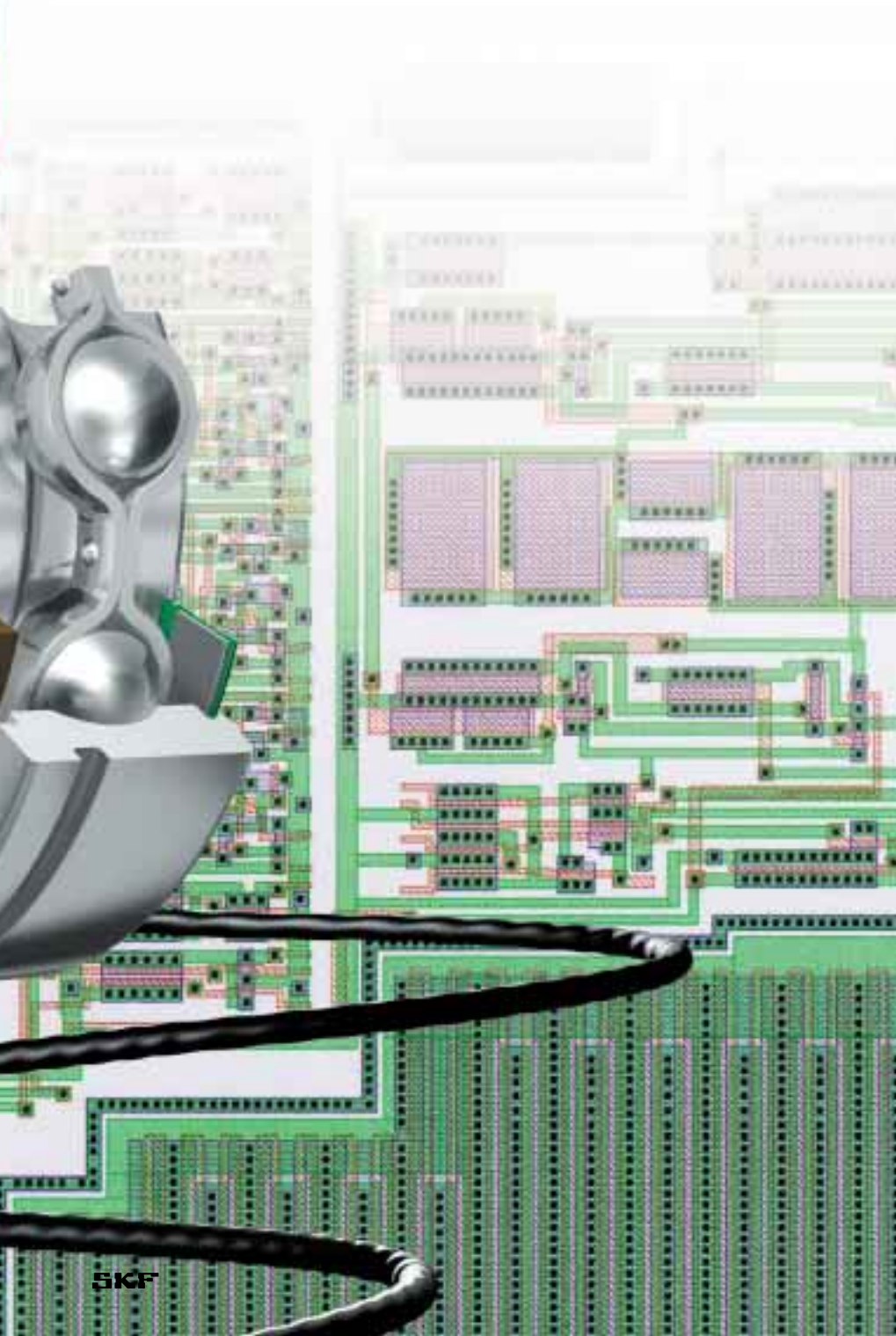

When quality and reliability count

High reliability, good signal quality, minimal liability to interference, compact design, simple mounting, long service life, economical operation and low total costs are requirements that must be met in many operations.

There is a large number of widely differing applications for the SKF Sensor-Bearing Unit, e.g.

- for control of electric motors,
- for control of linear actuators,
- for control of steering systems
- for speed synchronism,
- for detection of speed and direction of rotation, e.g. in electric vehicles, packaging machines, papermaking machines, textile machines, sorting machines, etc.

Further applications are conceivable. The application schemes described in the following show how close co-operation between SKF and the customer can solve special problems in practice using SKF Sensor-Bearing Units.

The applications

- Vehicles
- Electric motors
- Gear units
- Conveying and handling systems
- Linear actuators
- Control units
- Escalator synchronism
- Elevator management
- Roll, unroll, length measurement
- Mechanical engineering

The requirements

- High reliability
- Uniform and high signal quality
- Minimal liability to interference
- Insensitivity to vibration
- Insensitivity to high temperatures
- Compact design
- Simple installation
- Total cost savings

The SKF solution





1



Steer-by-wire in fork-lift trucks

An important prerequisite to improved performance of industrial trucks is the ergonomic design of the driver's seat and cabin preventing excessive driver fatigue.

The concept initially developed for a fork-lift truck, namely a steer-by-wire system equipped with two SKF Sensor-Bearing Units, avoids the inconvenience of a steering column. The Sensor-Bearing Units record the steering movement of the steering wheel, transmit a steering angle set value signal to the electronic control unit which then calculates the required regulating distance for the wheel to be steered and triggers a steering motor.

Limited space was available for the bearing arrangement of the steering wheel shaft and the sensor units. The design had to be sufficiently robust to accommodate all forces occurring in operation and the sensor system had to correspond to the legal security stipulations. SKF Sensor-Bearing Units adapted to this special application fulfilled these demands.

The unique SKF design of Sensor-Bearing Units is also successfully used in various other steer-by-wire or position control systems, such as marine and military applications, off-road and agricultural vehicles, as well as industrial handling systems.



SKF steer-by-wire module for industrial vehicles



Motor control in three-phase drives

The conversion from direct current drives to more versatile, robust and virtually maintenance-free three-phase drives made an electronic circuit with sensors for speed recording a necessity in motor control. The installation of a bearing with integral sensor was considered to be the best solution.

SKF Sensor-Bearing Units contribute to the outstanding performance of the three-phase drive. The SKF Sensor-Bearing Unit, which does not require any extra space, is located in a protected position in the motor and yields a uniform and reliable signal. Thanks to the unit concept, only one fitting operation is required to get the bearing and the sensor functions installed. As quality and function are already checked in bearing manufacture, minimum effort is required for system integration.

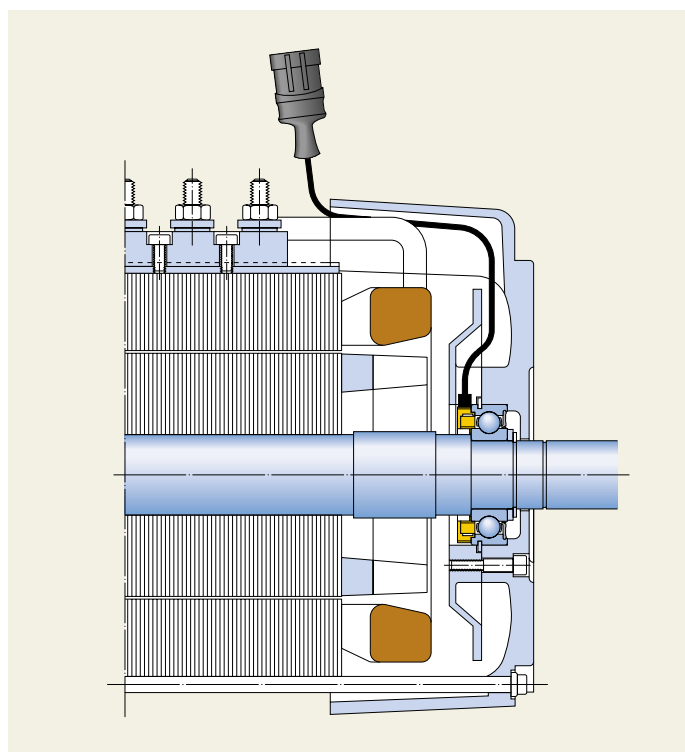

The SKF Sensor-Bearing Unit occupies no extra space, is well protected inside the motor and provides a reliable and steady signal

Application of units

Selection of bearing size

SKF Sensor-Bearing Units carry rather high radial loads as well as axial loads in both directions. They are suitable for high speeds and robust in operation and maintenance. The sensor unit integral with the bearing enables recording of operating data.

The selection of the correct size of SKF Sensor-Bearing Unit depends on the same factors as that of a normal deep groove ball bearing, as far as bearing function is concerned. Bearing life is determined on the basis of the load carrying capacity of the bearing and the loads and operating conditions of the application, using the normal methods. The bearing data can be seen from the product table.

Unit arrangement

Two bearings are normally required to support a shaft – a locating and a non-locating bearing. Since the SKF Sensor-Bearing Unit is mainly to be used as a locating bearing, the opposite shaft end must be supported by a non-locating bearing. If high axial loads act on the SKF Sensor-Bearing Unit in both directions, it should be mounted in such a way that the higher axial loads act on the bearing outer ring face opposite to the sensor unit.

Radial location

SKF Sensor-Bearing Units are designed for the following application conditions:

- rotating inner ring with rotating load
- stationary outer ring with stationary load

In accordance with the general recommendations in these cases, the inner ring has a tight fit on the shaft and the outer ring a loose fit in the housing bore.

The sensor unit connection cable emerges from the bearing position in the radial direction and determines the position of the outer ring relative to the housing. A sufficiently dimensioned cable duct must be provided in the housing or housing cover.

It is recommended that the cable protruding from the sensor body, is protected against excessive rotation by a radial notch in the housing. That notch should be of a circumferential width of 9 to 15 mm. The notch depth should reach at least the side face of the bearing outer ring (→ fig 1). To avoid stress on the sensor body, it is required that the cable outlet do not touch the notch during assembly, therefore it is recommended that the Sensor-Bearing Unit is positioned angularly during the whole assembly process.

However, in the case of loose housing fit – and when the stationary load is including additionally dynamic forces – vibration can cause slight rotation of the outer ring (creeping). In order to get the best signal generation and processing the position of the cable must be fixed. To prevent creeping, we recommend the insertion of a nitrile rubber O-ring into the circumferential groove in the outer ring outside diameter (→ fig 1).

Fig 1

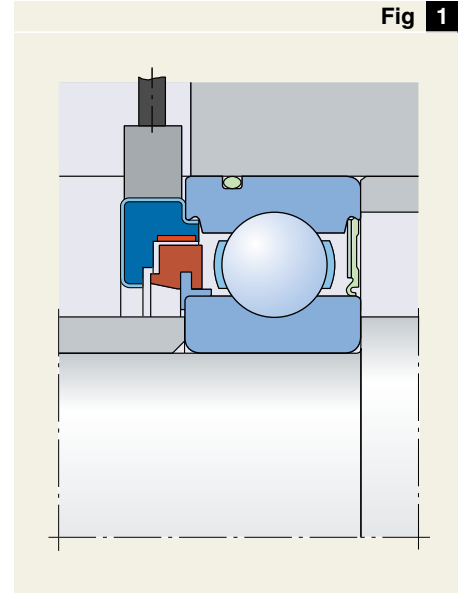

Notch in the housing and location of outer ring in circumferential direction by an O-ring inserted in the snap ring groove

Axial location of the outer ring of small bearings using a snap ring in the housing bore

Fig 2

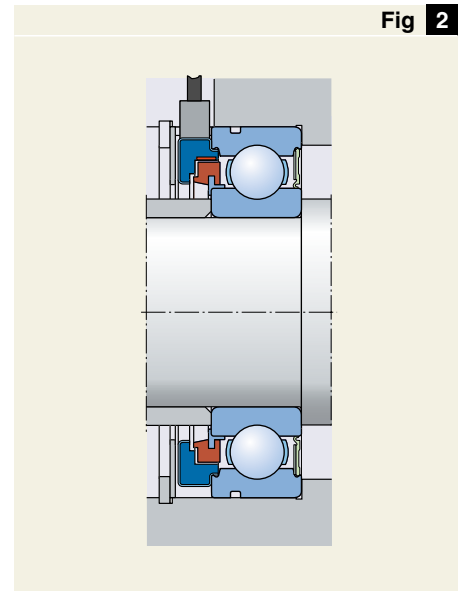

Axial location

The inner ring with tight fit is normally located in the axial direction on both sides, e.g. by a shaft shoulder, a distance sleeve or a snap ring. The axial location of the outer ring depends on the bearing size.

- With bearings up to and including a bore diameter of 25 mm the outer ring is located axially on the side opposite to the sensor unit by a shoulder in the housing bore. If the bearing is only subjected to light loads or not loaded at all in the opposite direction, a snap ring engaging a groove in the housing bore is sufficient for axial location on the sensor side. Between snap ring and sensor body an annular steel sheet washer must be fitted, abutting the sensor body over its entire width (→ **fig 2**). A sufficiently dimensioned recess must be provided in the housing for taking up the sensor unit connecting cable.

Axial location of the outer ring of small bearings using a snap ring in the outer ring and an end cover

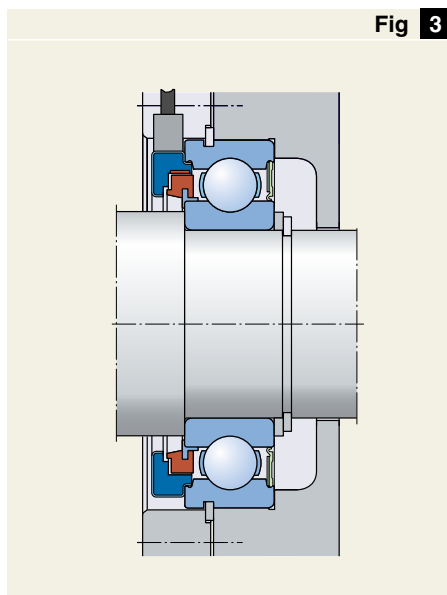
**Axial location**

In the event of higher axial loads occurring we recommend location of the bearing with an end cover bolted to the housing via a snap ring in the groove of the outer ring. In this case a recess must be provided as cable duct in the cover (→ **fig 3**). The abutment dimensions can be found in the product table.

- With bearings having a bore diameter of 30 mm and more the outer ring is fitted in such a way that the side face opposite to the sensor unit abuts a housing shoulder. There are two ways of axially locating the bearing on the sensor side:

A thin-walled distance sleeve slotted in the axial direction is inserted into the housing bore so that it abuts the bearing and location is provided by a snap ring. The sleeve inside diameter must match the outside diameter of the sensor unit, and its outside diameter must correspond to the housing bore diameter. The width of the sleeve slot must be determined in accordance with the dimensions of the connecting cable

Axial location of the outer ring of larger bearings using a distance sleeve and a snap ring in the housing bore

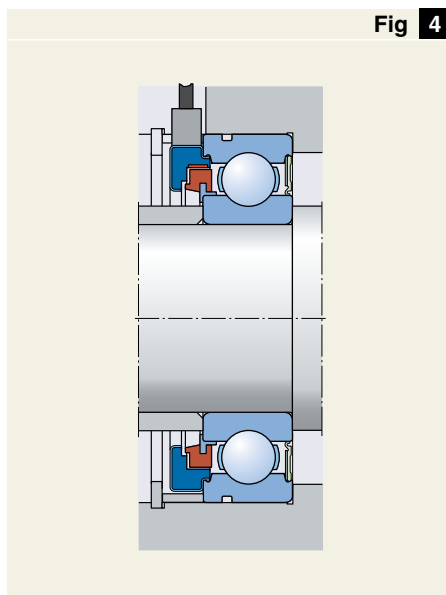

where it emerges from the sensor unit. The distance sleeve covers the distance between the outer ring side face and the snap ring and must be so wide that the snap ring, when inserted into the annular groove, abuts the distance sleeve, but not the sensor ring (→ **fig 4**).

With these bearing sizes the ring side face not covered by the sensor body in most cases, however, is sufficiently wide to allow reliable location using an end cover bolted to the housing. The cover abuts the outer ring side face and must be provided with a recess for the cable (→ **fig 5**). The abutment dimensions can be found in the product table.

If the SKF Sensor-Bearing Unit is used as a non-locating bearing, which should only be considered in exceptional cases, the outer ring must be free to move axially in both directions. Care must be taken that this axial displacement is not impeded by the connecting cable, while outer ring rotation should be prevented.

Axial location of the outer ring of larger bearings using an end cover

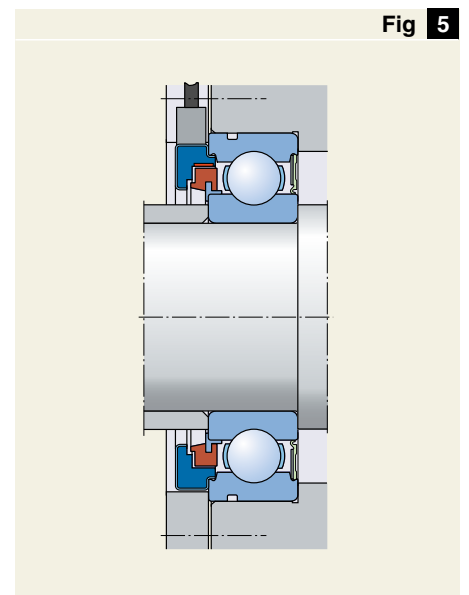

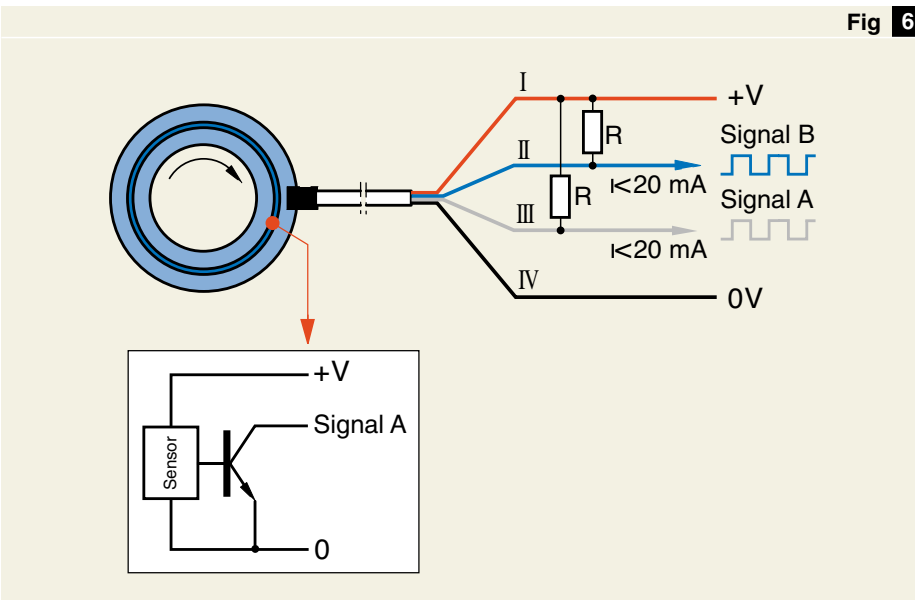

Fig 6

Circuit diagram

Electrical interface data

Active sensor operation requires a regulated supply voltage of 5 to 24 V. Signal output is effected via an open collector (→ fig 6). Resistors inserted between the conductor connected to the voltage supply and the conductors for the output signals limit the output current to 20 mA (→ table 1). For signal output features → table 2.

Table 1

| Voltage V | Recommended resistors R | |
|--------------|----------------------------|--------|
| | Ω | P W |
| 5 | 270 | 0,25 |
| 9 | 470 | 0,25 |
| 12 | 680 | 0,25 |
| 24 | 1 500 | 0,5 |

Electrical parameters

Signal output features

Table 2

| Technical data | |
|-------------------|------------------|
| Signal type | Digital square |
| Number of signals | 2 |
| Phase shift | 90 degrees |
| Duty cycle | 50 % of a period |

Mounting

On mounting, SKF Sensor-Bearing Units must be handled with great care in order to avoid damage to the sensor unit and the connecting cable.

First the bearing ring having a tight fit, which is the inner ring in this case, is pressed onto its seating surface. The pressing-in force must be applied only onto a mounting sleeve abutting the inner ring side face, either by hand or using a press (→ fig 7). The pressing-in force must under no circumstances be applied to the sensor unit.

Bearing mounting is simplified when the bearings are heated. However, only a temperature-controlled electric hot plate must be used and the temperature of 80 °C must not be exceeded. The bearing must not be placed directly on the hot plate, but a mandrel must be inserted in the bearing bore. This mandrel transfers the heat from the hot plate to the bearing inner ring and ensures an adequate distance from the bearing to the hot plate (→ fig 8).

In order to insert the bearing with loose outer ring fit into the housing, it must be centred relative to the housing bore and must not be tilted or misaligned during insertion (→ fig 9).

Above all, care must be taken that the cable outlet does not touch other parts, and that the connecting cable passes through the cable hole and cannot be bent or squeezed on mounting.

For special requirements, SKF provides on request customised assistance in optimising the process of mounting and connection.

Warning

When heating the bearing the connecting cable must not come into contact with the hot plate (→ fig 3). An induction heater must not be used for heating SKF Sensor-Bearing Units as this would cause fatal damage to the electronic components.

Pressing of inner ring onto the shaft seat using a mounting sleeve

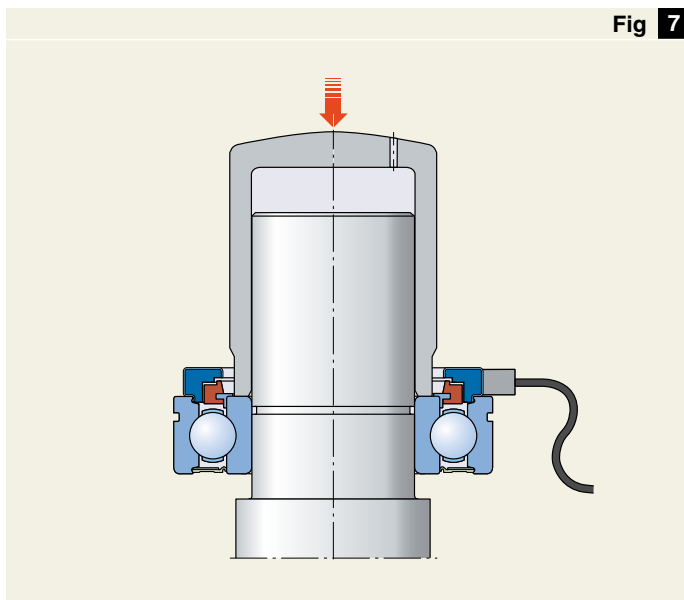

Heating of bearing before mounting onto the shaft

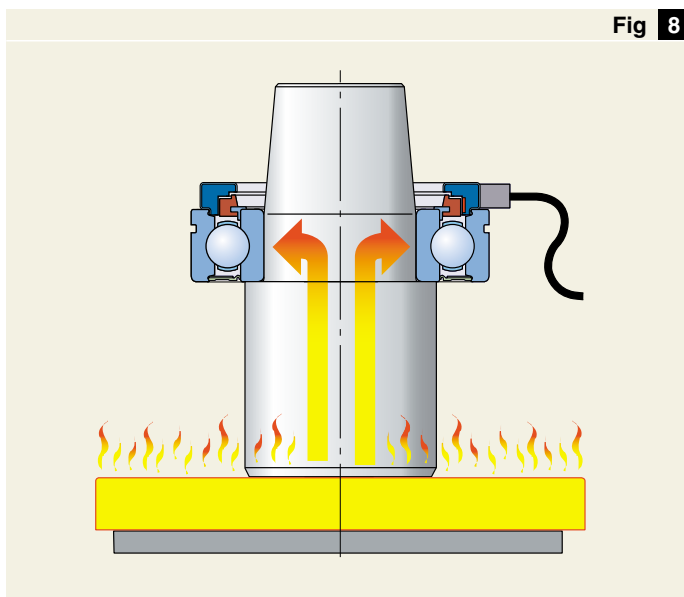

Vertical assembly of end-frame and Sensor-Bearing Unit

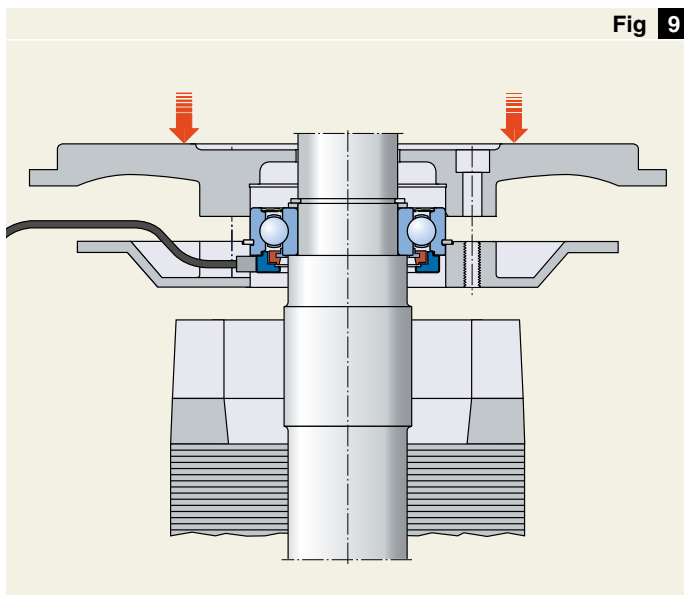

Lubrication and maintenance

The SKF Sensor-Bearing Units from the standard range are supplied as sealed bearing units ready for mounting. They are filled with a polyurea grease suitable for the temperature range of the sensor unit (between -40 and +120 °C), ensuring reliable lubrication for the entire bearing life. The grease fill is adapted to the bearing sizes. Thus SKF Sensor-Bearing Units are maintenance-free.

2

General unit data

Design

An SKF Sensor-Bearing Unit (→ fig 1) consists of

- a standard deep groove ball bearing with one seal and one snap ring groove in the outside surface of the outer ring (a)
- the magnetised impulse ring (b)
- the sensor body (c)
- the connecting cable (d).

On the one side the bearing is fitted with a standard seal sealing against the inner ring shoulder. On the opposite side the impulse and sensor body form an effective labyrinth seal.

The impulse ring is a composite magnetised ring. The number of north and south poles (between 32 and 80) depends on the size of the bearing. The impulse ring is attached to the bearing inner ring.

The sensor body protecting two embedded Hall cells is attached to the outer ring – a patented SKF solution.

The multiwire connecting cable extending in radial direction, which connects the SKF Sensor-Bearing Unit and the signal processing electronics, has a standard length of approximately 500 mm. In order to take into account the different requirements to the interface between the SKF Sensor-Bearing

Fig 1

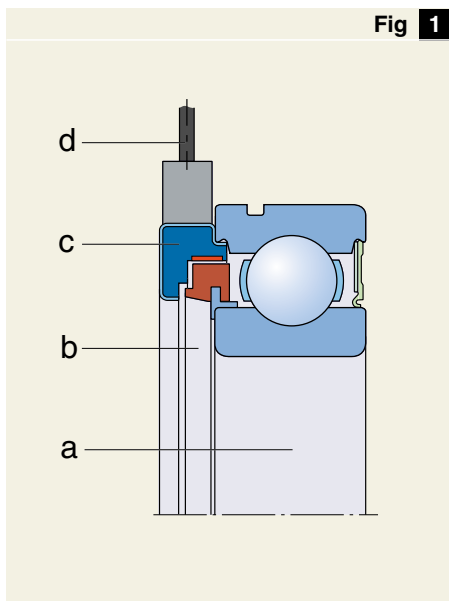

Components of SKF Sensor-Bearing Unit

Fig 2

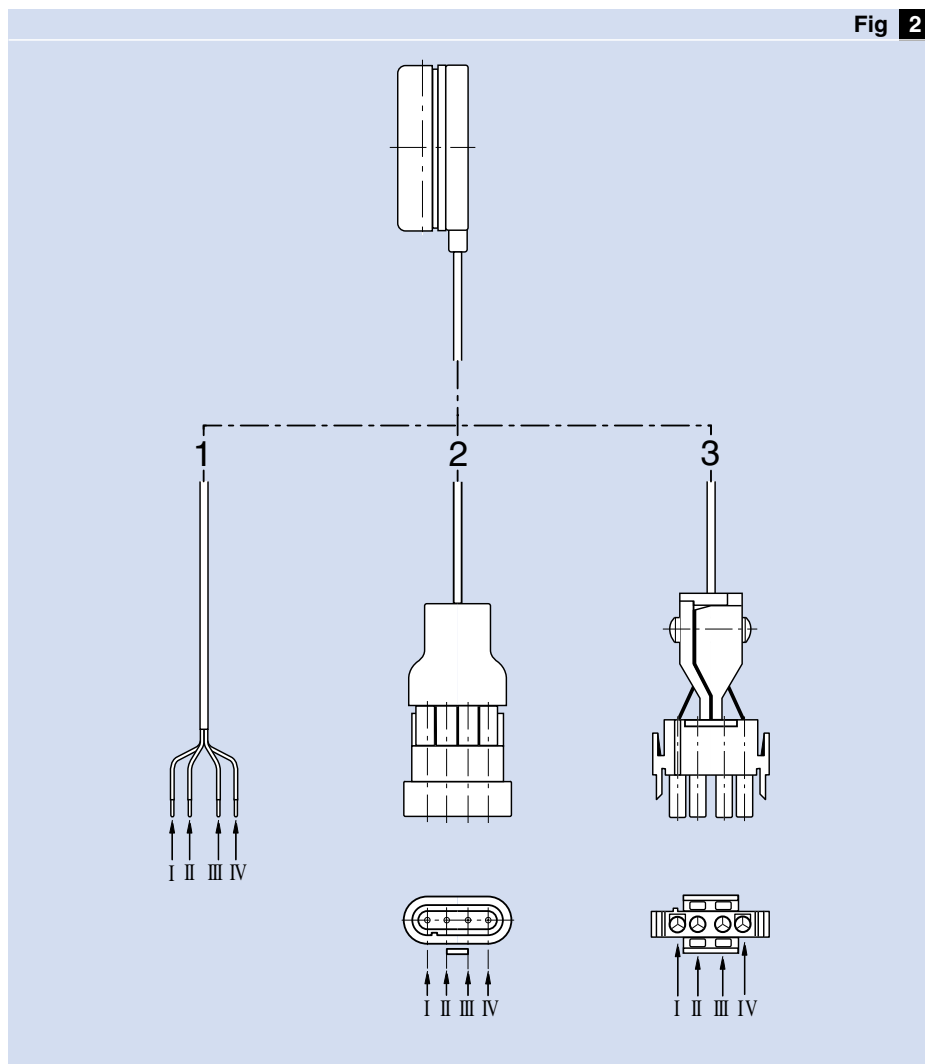

Different versions of connecting cable ends

Unit and the electronic unit normally developed by the customer, the different unit sizes are available with free cable end, and can be delivered on request with two different standard connectors (→ fig 2).

- Version 1 Free cable end
- Version 2 Plug connection AMP Superseal, AMP Nos. 282106-1 and 282404-1
- Version 3 Plug connection AMP Mate-N-Lock, AMP Nos. 350779-1, 350811-1 and 350924-1

Table 1

| Bore d | Radial internal clearance C3 | |
|-----------|------------------------------|-----|
| | min | max |
| mm | µm | |
| 15 | 11 | 25 |
| 20 | 13 | 28 |
| 25 | 13 | 28 |
| 30 | 13 | 28 |
| 40 | 15 | 33 |
| 45 | 18 | 36 |

Radial internal clearance of SKF Sensor-Bearing Units

Dimensions

SKF Sensor-Bearing Units are based on deep groove ball bearings of series 62. Their boundary dimensions are identical with those of dimension series 02 in accordance with ISO 15:1998. However, more space must be provided in the axial direction, as the unit is wider due to the integral sensor.

Tolerances

The bearings of the SKF Sensor-Bearing Units are manufactured to normal tolerances as standard. The values of these tolerances conform to ISO 492:1994.

Radial internal clearance

In accordance with the requirements of the major applications, especially of electric machine constructions, SKF Sensor-Bearing Units have radial internal clearance C3 as specified for deep groove ball bearings in ISO 5753:1991. The values given in table 1 apply to bearings in unmounted condition under zero measuring load.

Permissible speeds

The SKF Sensor-Bearing Unit is suitable for the limiting speed valid for the corresponding deep groove ball bearing with seals. If the bearings are to be operated at higher speeds than indicated in the product table, SKF should first be contacted.

Operating temperature range

Extensive long-term testing in the laboratory showed that our SKF Sensor-Bearing Units can be used in a temperature range between -40 and +120 °C. For constant temperatures exceeding +120 to +150 °C special versions are available, subject to in-depth checking of the application in question.

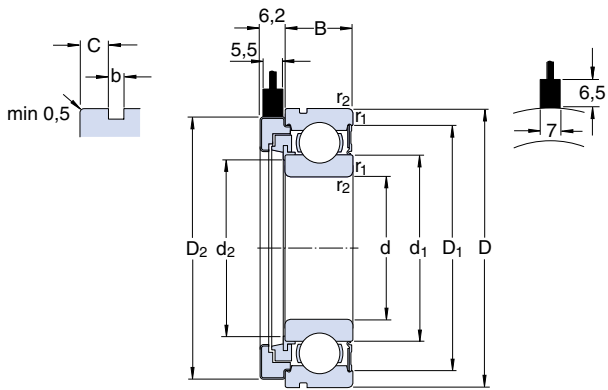

| Bearing | | | Basic load ratings | | Fatigue load limit P_u | Limiting speed | Sensor unit | | Phase shift | Mass | Designation Unit with 500 mm long cable but without connector |
|----------------------|----|----|--------------------|--------|--------------------------|----------------|------------------|-----------------|-------------|------|--|
| Principal dimensions | | | dynamic | static | | | Number of pulses | Period accuracy | | | |
| d | D | B | C | C_0 | | | | | degrees | kg | – |
| mm | | | kN | | kN | r/min | – | % | | | |
| 15 | 35 | 11 | 8,06 | 3,75 | 0,16 | 13 000 | 32 | ± 3 | 90 ± 30 | 0,06 | BMB-6202/032S2/EA002A |
| 20 | 47 | 14 | 13,5 | 6,55 | 0,28 | 10 000 | 48 | ± 3 | 90 ± 30 | 0,15 | BMB-6204/048S2/EA002A |
| 25 | 52 | 15 | 14,8 | 7,8 | 0,34 | 8 500 | 48 | ± 3 | 90 ± 30 | 0,18 | BMB-6205/048S2/EA002A |
| 30 | 62 | 16 | 20,3 | 11,2 | 0,48 | 7 500 | 64 | ± 4 | 90 ± 45 | 0,22 | BMB-6206/064S2/EA002A |
| 40 | 80 | 18 | 32,5 | 19 | 0,8 | 5 600 | 80 | ± 5 | 90 ± 45 | 0,40 | BMB-6208/080S2/EB002A |
| 45 | 85 | 19 | 35,1 | 21,6 | 0,92 | 5 000 | 80 | ± 5 | 90 ± 45 | 0,44 | BMB-6209/080S2/EB002A |

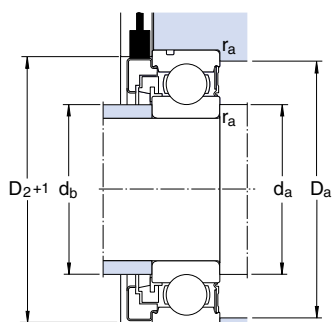

Bore diameter of end cover $\geq D_2 + 1$ (mm)

Dimensions

Abutment and fillet dimensions

| d | d ₁ ≈ | d ₂ | D ₁ ≈ | D ₂ | b | C | r _{1,2} min | d _a min | d _b min | d _b max | D _a max | r _a max |
|----|---------------------|----------------|---------------------|----------------|------|------|-------------------------|-----------------------|-----------------------|-----------------------|-----------------------|-----------------------|
| mm | | | | | | | | mm | | | | |
| 15 | 21,5 | 19,5 | 30,4 | 34,4 | 1,35 | 2,06 | 0,6 | 19 | 19 | 19,4 | 31 | 0,6 |
| 20 | 28,5 | 26,4 | 40,6 | 46,4 | 1,35 | 2,06 | 1 | 25 | 25 | 26,3 | 42 | 1 |
| 25 | 34 | 31,8 | 46,3 | 51,4 | 1,35 | 2,46 | 1 | 30 | 30 | 31,5 | 47 | 1 |
| 30 | 40,3 | 37,8 | 54,1 | 58 | 1,9 | 3,28 | 1 | 35 | 35 | 37,5 | 57 | 1 |
| 40 | 52,6 | 48 | 69,8 | 75 | 1,9 | 3,28 | 1,1 | 46,5 | 46,5 | 47,5 | 73,5 | 1 |
| 45 | 57,6 | 53 | 75,2 | 78,8 | 1,9 | 3,28 | 1,1 | 51,5 | 51,5 | 52,5 | 78,5 | 1 |

Further SKF sensorised bearing units

The SKF range of sensorised bearings is not limited to deep groove ball bearings. In the course of the development, the sensor concept was implemented with other bearing types as well.

Sensorised bearing units for road vehicles

Today pioneering developments in engineering often start in vehicle construction. The demand for constantly decreasing fuel consumption results in the components becoming more and more compact and more and more functions being integrated. With requirements of passive and active safety increasing this might present a contradiction in terms.

The anti-lock braking system for example significantly increased the active safety of a car, and the integration of the sensors into the bearing, which was achieved by SKF, made it a top product. Less components, more compact construction and simplified mounting are the OEM benefits. The user benefits are uniform and high signal accuracy, minimum liability to interference and long service life.

Today millions of SKF wheel bearing units with integral sensors are in use, in cars as well as in trucks.



Sensorised bearing units for rail vehicles

Operating conditions in rail vehicles are especially arduous. The bearings must not only tolerate vibration, impact loads, high loads and extreme temperatures, but must ensure high distances driven with high operational reliability over great distances and with long maintenance intervals. The same is true of the integral sensors which control the braking system, ensure optimum frictional engagement of the driving wheels on starting-up and detect the direction of rotation.

The SKF sensorised bearings for rail vehicles meet these requirements. They are compact, ready-to-mount and easy-to-install systemised solutions, having a cylindrical roller bearing (CRU) or taper roller bearing (TBU) as basic bearing.

Apart from these bearing units with speed sensors, bearing units with temperature sensors are also available from SKF. They allow immediate and permanent monitoring of bearing temperature, preventing hot-running axleboxes and bearing damage in operation.

Sensorised bearing units for traction motors

Based on its many years of experience with sealed and greased for life bearing units as well as integral speed and temperature sensors SKF developed Traction Motor Bearing Units (TMBU).

The version for the non-driven side is a deep groove ball bearing with flanged outer ring for attachment to the motor case and, if required, with an inner ring flange for attachment to the rotor shaft. These units can be supplied with or without integral speed and temperature sensors. Sealing of the bearing unit and position and attachment of the sensor are identical with the axlebox bearings.

The version for the drive side has a single row cylindrical roller bearing combined with a four point contact ball bearing as basic bearings.

The SKF Traction Motor Bearing Concept combines in one unit all functions important for the bearing arrangement, also including the insulation, if required.



The SKF Group - a worldwide corporation

SKF is an international industrial Group operating in some 130 countries and is world leader in bearings.

The company was founded in 1907 following the invention of the self-aligning ball bearing by Sven Wingquist and, after only a few years, SKF began to expand all over the world.

Today, SKF has some 40 000 employees and around 80 manufacturing facilities spread throughout the world. An international sales network includes a large number of sales companies and some 7 000 distributors and retailers. Worldwide availability of SKF products is supported by a comprehensive technical advisory service.

The key to success has been a consistent emphasis on maintaining the highest quality of its products and services. Continuous investment in research and

development has also played a vital role, resulting in many examples of epoch-making innovations.

The business of the Group consists of bearings, seals, special steel and a comprehensive range of other high-tech industrial components. The experience gained in these various fields provides SKF with the essential knowledge and expertise required in order to provide the customers with the most advanced engineering products and efficient service.



SKF



The SKF Group is the first major bearing manufacturer to have been granted approval according to ISO 14001, the international standard for environmental management systems. The certificate is the most comprehensive of its kind and covers more than 60 SKF production units in 17 countries.



The SKF Engineering & Research Centre is situated just outside Utrecht in The Netherlands. In an area of 17 000 square metres (185 000 sq.ft) some 150 scientists, engineers and support staff are engaged in the further improvement of bearing performance. They are developing technologies aimed at achieving better materials, better designs, better lubricants and better seals – together leading to an even better understanding of the operation of a bearing in its application. This is also where the SKF Life Theory was evolved, enabling the design of bearings which are even more compact and offer even longer operational life.



SKF has developed the Channel concept in factories all over the world. This drastically reduces the lead time from raw material to end product as well as work in progress and finished goods in stock. The concept enables faster and smoother information flow, eliminates bottlenecks and bypasses unnecessary steps in production. The Channel team members have the knowledge and commitment needed to share the responsibility for fulfilling objectives in areas such as quality, delivery time, production flow etc.



SKF manufactures ball bearings, roller bearings and plain bearings. The smallest are just a few millimetres (a fraction of an inch) in diameter, the largest several metres. SKF also manufactures bearing and oil seals which prevent dirt from entering and lubricant from leaking out. SKF's subsidiaries CR and RFT S.p.A. are among the world's largest producers of seals.



® SKF is a registered trademark
of the SKF Group.

© Copyright SKF 2003

The contents of this publication are the
copyright of the publisher and may not
be reproduced (even extracts) unless
permission is granted. Every care has
been taken to ensure the accuracy of
the information contained in this pub-
lication but no liability can be accepted
for any loss or damage whether direct,
indirect or consequential arising out of
the use of the information contained
herein.

Publication **5106/II E** · December 2003

Printed in Sweden on environmentally
friendly, chlorine-free paper (Multiart Silk)
by SG Tryck AB.

www.skf.com