

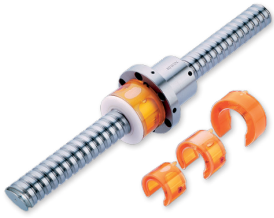

Crossed Roller Bearings

Technical Information



TAIWAN EXCELLENCE
GOLD AWARD 2009, 2008, 2005
TAIWAN EXCELLENCE
SILVER AWARD 2006, 2001, 1993



Ballscrews

Ground/Rolled

- High Speed (High Dm-N Value/Super S Series)
- Heavy Load (Cool type II)
- Self-Lubricating (E2)
- Rotating Nut (R1)
- For Heavy-Load Drive



TAIWAN EXCELLENCE
2002

Linear Actuator

- LAN for Hospital
- LAM for Industrial
- LAS Compact Size
- LAK Controller

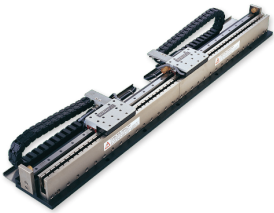

TAIWAN EXCELLENCE
GOLD AWARD 2004

Linear Synchronous Motor

- Coreless Type (LMC)
- Iron-core Type (LMS)



AC Servo Motor

AC Servo Motor Drives

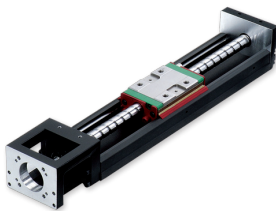

TAIWAN EXCELLENCE
GOLD AWARD 2010

Industrial Robot

- For Semiconductor & Electronic (KK Robot)
- For Automation (KS, KA Robot)

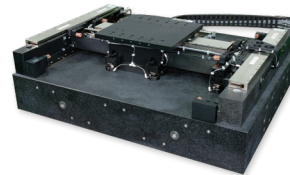

TAIWAN EXCELLENCE
SILVER AWARD 2009

Linear Motor

Air Bearing Platform

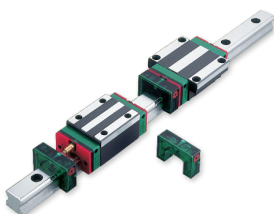

TAIWAN EXCELLENCE
GOLD AWARD 2008
TAIWAN EXCELLENCE
SILVER AWARD 2007, 2002



Linear Guideway

- HG/EG/RG/MG Type
- Self-Lubricating (E2)
- Low Noise (Q1)
- Air Jet (A1)

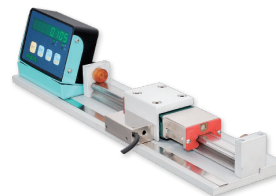

Positioning

Measurement System



TAIWAN EXCELLENCE
SILVER AWARD 2006

TMS Direct-Drive Positioning System

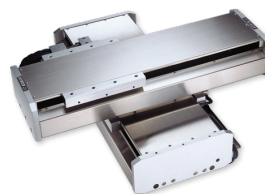

Linear Motor X-Y Robot



TAIWAN EXCELLENCE
2004

Positioning Guideway



Linear Motor Gantry

INDEX

HIWIN Crossed Roller Bearings (CRB Series)	1
Introduction	1
Product Features	1
Specification of Crossed Roller Bearing	1
Types of Crossed Roller Bearing	2
Structure of sealed type and open type	4
Accuracy	4
Selection of Crossed Roller Bearing	7
Dynamic Equivalent Load, P	7
Basic Rating Life, L	7
Static Equivalent Load, P_0	7
Safety Factor, f_s	8
Example for the calculation of the basic rating life and the safety factor	8
Fitness	9
Fixing way and design of housing and mounting disc	9
Installing steps	10
Other description	11
Description of lubrication	11
Description of allowable revolution	11
Use cautions	11
CRBA Product Specification	12
CRBB Product Specification	13
CRBC Product Specification	14
CRBD Product Specification	15
CRBE Product Specification	16

HIWIN Crossed Roller Bearings (CRB Series)

Introduction

HIWIN Crossed Roller Bearing is mainly consisted of an outer ring, an inner ring, a plurality of rollers and a plurality of spacers. The roller lies between the inner ring and the outer ring. The spacer is placed between rollers to prevent the mutual friction between rollers so as to decrease the torque resistance for rotation. In addition, the surface of the roller and the rolling track is linear contact. So, when the bearing is loaded, the loading area will be very large. Thus, the elastic deformation will be less, and the bearing will achieve a long service life. Each roller in Crossed Roller Bearing is crossed at 90° angle, which is able to bear the loading force from axial, radial and the other direction at the same time.

HIWIN Crossed Roller Bearings comprise six types, which could be recognized as the split outer ring type (CRBA), the split inner ring type (CRBB), the high rigidity type (CRBC), the split outer ring with mounting holes (CRBD), the high rigidity with mounting holes (CRBE) and the customized type (CRBX). The split outer ring type is suitable for rotating of inner ring. The split inner ring type is suitable for rotating of outer ring. The high rigidity type is suitable for rotating of inner ring and outer ring both. The mounting holes could facilitate the assembly. The customized type could be modified to meet the requirements of the customer. Various Crossed Roller Bearings possess high rigidity and high rotation accuracy, which could be widely used in industrial automation control, robot, tool machinery, inspection and medical devices.

Product Features

1. Patented high loading capacity
2. High rigidity
3. The rotation accuracy is higher than the international standard
4. Taking loads from all directions at the same time
5. Smooth rotation
6. Small volume, space saving
7. Easy installation and adjustment
8. Various bearing types and dimensions for your requirements
9. Providing customized design



Specification of Crossed Roller Bearing

CRB ○ □ □ □ △ △ ◇ WW C8 P5

1. CRB ○ : Model code of bearings. CRB stands for Crossed Roller Bearing. ○ comprises six types, which could be recognized as following: A: split outer ring type. B: split inner ring type. C: high rigidity type. D: split outer ring with mounting holes. E: high rigidity with mounting holes. X: customized type in particular.
2. □ □ □ : Bore diameter of bearings (unit: mm). For example, 080 represent the bore diameter in 80 mm, and 100 represent the bore diameter in 100 mm.
3. △ △ : Width of bearing (unit: mm).
4. ◇ : Mounting holes symbol. With blank space means the bearing without mounting hole. A is represented the bearing with mounting screw holes, while B is symbolized the bearing with same direction mounting sink holes, and C is symbolized the bearing with opposite direction mounting sink holes.
5. WW: Seal symbol. WW signifies the seals at both sides. NN signifies the open type without seals. Both types have oil holes for lubrication.
6. C8: Axial internal clearance classification. C1 signifies positive clearance with less friction force, while C8 signifies negative clearance without backlash, which will result in increase of friction force by unloading condition.
7. P5: Accuracy class symbol which contains General Class (P0), Class 5 (P5), Class 4 (P4), Class 2 (P2), Class D5 (PD5), Class D4 (PD4) and Class D2 (PD2). Please see Table 1~7 for standard of accuracy grade for bearings.

CRBD 080 22 A WW C8 P5

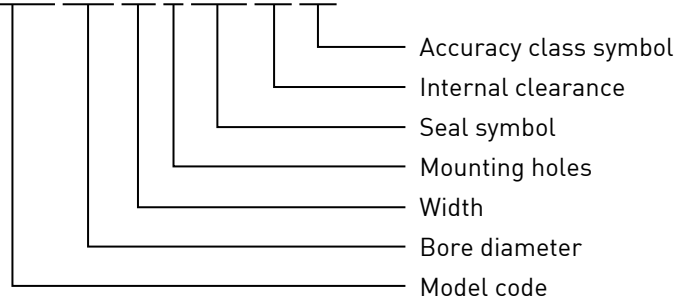

Types of Crossed Roller Bearing

1. **Split outer ring type (CRBA):** Consisted of an inner ring and two outer semi-rings, which is suitable for rotating of inner ring.

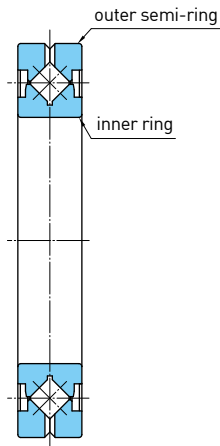

2. **Split inner ring type (CRBB):** Consisted of two inner semi-rings and an outer ring, which is suitable for rotating of outer ring.

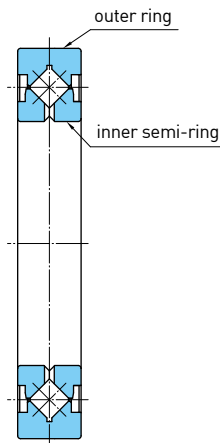

3. **High rigidity type (CRBC):** Consisted of an inner ring and an outer ring, which is suitable for rotating of inner ring and outer ring both.

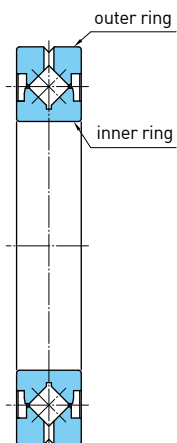

4. Split outer ring with mounting holes (CRBD): Consisted of an inner ring and two outer semi-rings with mounting holes. Because there are mounting holes, so it can be fixed directly and it is suitable for rotating of inner ring.



5. High rigidity with mounting holes (CRBE): Consisted of an inner ring and an outer ring with mounting holes. Because there are mounting holes, so it can be fixed directly and it is suitable for rotating of inner ring and outer ring both.

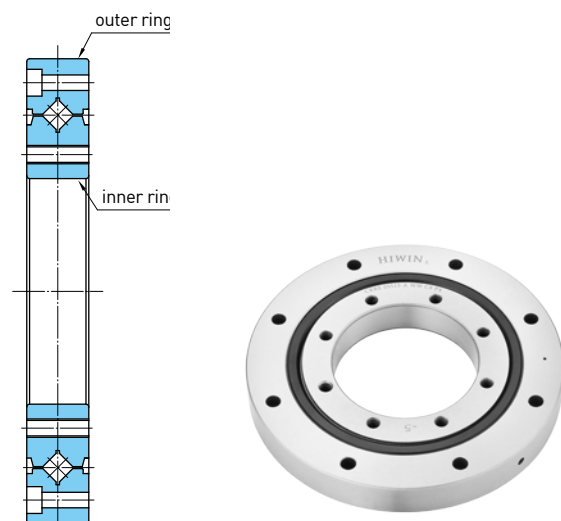

6. Customized type (CRBX): The bearing could be designed and modified in accordance with the requirements of customer with more innovative structure. The surface treatment could also be conducted in accordance with the environmental requirements of customer.



Structure of sealed type and open type

1. Sealed type: The seal has very good sealing effect, which is able to effectively prevent the foreign substance from entering the track, and prevent the lubricant leaking from the track. In addition, the seal has oil holes for lubricating.
2. Open type: There is no seal. The friction resistance is smaller. It is suitable for the use of low torque. The open type also has oil holes for lubricating.

Accuracy

Table 1 Accuracy for bore diameter of Crossed Roller Bearings

 Unit : μm

Nominal bore diameters, d (mm)		Bore diameter deviations, Δd_{mp}					
		P0、P5、P4、P2		PD5		PD4、PD2	
over	include	high	low	high	low	high	low
18	30	-1	-9	-1	-6	-1	-5
30	50	-2	-11	-2	-7	-2	-6
50	80	-3	-13	-3	-9	-3	-7
80	120	-3	-15	-3	-10	-3	-8
120	150	-4	-18	-4	-11	-4	-9
150	180	-4	-25	-4	-13	-4	-10
180	250	-4	-30	-4	-15	-4	-11
250	315	-5	-35	-5	-18	-	-

 Note: " d_{mp} " means the average of maximum value and minimum value of the inner diameter.

Table 2 Accuracy for outside diameter of Crossed Roller Bearings

 Unit : μm

Nominal outside diameters, D (mm)		Outside diameter deviations, ΔD_{mp}					
		P0、P5、P4、P2		PD5		PD4、PD2	
over	include	high	low	high	low	high	low
18	30	-1	-9	-1	-6	-1	-5
30	50	-2	-11	-2	-7	-2	-6
50	80	-3	-13	-3	-9	-3	-7
80	120	-3	-15	-3	-10	-3	-8
120	150	-4	-18	-4	-11	-4	-9
150	180	-4	-25	-4	-13	-4	-10
180	250	-4	-30	-4	-15	-4	-11
250	315	-5	-35	-5	-18	-5	-13
315	400	-6	-40	-6	-20	-6	-15
400	500	-7	-45	-7	-23	-	-

 Note: " D_{mp} " means the average of maximum value and minimum value of the outside diameter.

Table 3 Accuracy for width of Crossed Roller Bearings

 Unit : μm

Nominal bore diameters, d (mm)		Deviations of inner (or outer) ring width, $\Delta B_s, \Delta T_s$					
		CRBA inner ring, CRBD inner ring		CRBA outer ring, CRBD outer ring			
		CRBB outer ring		CRBB inner ring			
		CRBC inner ring, CRBC outer ring					
		CRBE inner ring, CRBE outer ring					
over	include	high	low	high	low	high	low
18	30	0	-75	0		0	-100
30	50	0	-75	0		0	-100
50	80	0	-75	0		0	-100
80	120	0	-75	0		0	-100
120	150	0	-100	0		0	-120
150	180	0	-100	0		0	-120
180	250	0	-100	0		0	-120
250	315	0	-120	0		0	-150

Table 4 Rotation Accuracy for inner ring of CRBA and CRBC

Unit : μm

Nominal bore diameters, d (mm)		Radial run out of inner ring, K_{ia}			Inner ring face run out with raceway, S_{ia}	
		P0	PD5	PD4	PD5	PD4
			P5	P4	P5	P4
over	include	max	max	max	max	max
18	30	10	3	3	4	3
30	50	12	4	3	5	3
50	80	15	4	3	5	4
80	120	19	5	4	6	4
120	150	23	6	5	8	6
150	180	23	6	5	8	6
180	250	30	8	6	10	6
250	315	38	10	8	13	8

Note: 1. Radial run out of inner ring (K_{ia}) and inner ring face run out with raceway (S_{ia}) are not used on CRBB type.
2. Hiwin run out tolerance limit is defined as only 75% amount of standard ISO 199,492,582.

Table 5 Rotation Accuracy for inner ring of CRBB and CRBC

Unit : μm

Nominal outside diameters, D (mm)		Radial run out of outer ring, K_{ea}			Outer ring face run out with raceway, S_{ea}	
		P0	PD5	PD4	PD5	PD4
			P5	P4	P5	P4
over	include	max	max	max	max	max
18	30	12	5	3	6	4
30	50	15	6	4	6	4
50	80	19	6	4	8	4
80	120	27	8	5	9	5
120	150	30	9	6	10	6
150	180	34	10	6	11	6
180	250	38	12	8	12	8
250	315	45	14	9	14	8
315	400	53	15	10	15	10
400	500	60	18	12	18	12

Note: 1. Radial run out of outer ring (K_{ea}) and outer ring face run out with raceway (S_{ea}) are not used on CRBA type.
2. Hiwin run out tolerance limit is defined as only 75% amount of standard ISO 199,492,582.

Table 6 Rotation Accuracy for inner ring and outer ring of CRBD

Unit : μm

Bearing No.	Radial run out of inner ring, K_{ia}			Inner ring face run out with raceway, S_{ia}		Radial run out of outer ring, K_{ea}			Outer ring face run out with raceway, S_{ea}	
	P0	PD5	PD4	PD5	PD4	P0	PD5	PD4	PD5	PD4
		P5	P4	P5	P4		P5	P4	P5	P4
max	max	max	max	max	max	max	max	max	max	max
CRBD 02012	10	3	3	4	3	19	6	4	8	4
CRBD 03515	12	4	3	5	3	27	8	5	9	5
CRBD 05515	15	4	3	5	4	27	8	5	9	5
CRBD 08022	15	4	3	5	4	34	10	6	11	6
CRBD 09025	19	5	4	6	4	38	12	8	12	8
CRBD 11528	19	5	4	6	4	38	12	8	12	8
CRBD 16035	23	6	5	8	6	45	14	9	14	8

Note: Hiwin run out tolerance limit is defined as only 75% amount of standard ISO 199,492,582.

Table 7 Rotation Accuracy for inner ring and outer ring of CRBE

Unit : μm

Bearing No.	Radial run out of inner ring, K_{ia}		Inner ring face run out with raceway, S_{ia}		Radial run out of outer ring, K_{ea}		Outer ring face run out with raceway, S_{ea}	
	PD2	PD4	PD2	PD4	PD2	PD4	PD2	PD4
	P2	P4	P2	P4	P2	P4	P2	P4
	max	max	max	max	max	max	max	max
CRBE 02012	2	3	2	3	3	4	3	4
CRBE 03515	2	3	2	3	4	5	4	5
CRBE 05515	2	3	2	4	4	5	4	5
CRBE 08022	2	3	2	4	4	6	4	6
CRBE 09025	2	4	2	4	6	8	6	8
CRBE 11528	2	4	2	4	6	8	6	8
CRBE 16035	4	5	4	6	6	9	6	8
CRBE 21040	4	6	4	6	6	10	6	10

Note: Hiwin run out tolerance limit is defined as only 75% amount of standard ISO 199,492,582.

Table 8 Axial internal clearance

Unit : μm

Nominal bore diameters, d (mm)		Clearances			
		C8		C1	
over	include	min	max	min	max
30	50	-8	0	2	15
50	80	-10	0	2	20
80	120	-10	0	2	20
120	140	-10	0	2	20
140	160	-10	0	2	20
160	180	-10	0	2	20
180	200	-10	0	2	20
200	225	-10	0	2	20
225	250	-10	0	2	20
250	280	-15	0	2	25
280	315	-15	0	2	25

Note: The C8 clearance (negative clearance) should not be selected for P0

Selection of Crossed Roller Bearing

The general selection of Crossed Roller Bearing is shown as follows:

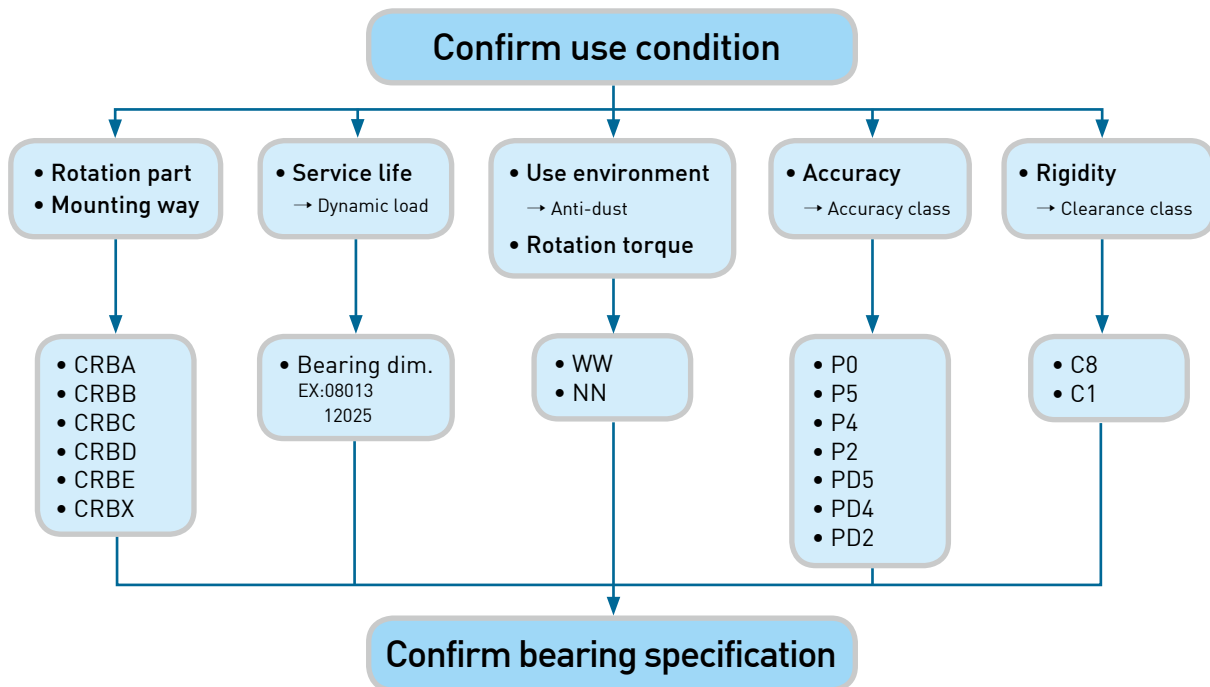

Dynamic Equivalent Load, P

When the bearing is dynamically acted by the radial load, axial load and torque, all loads can be combined to a load acting on the center of bearing. It is called the dynamic equivalent load, and can be shown by the equation (1):

$$P = X \left(F_r + \frac{2M}{D_{pw}} \right) + Y F_a \dots \dots \dots (1)$$

where, $X = 1, Y = 0.45$, for $\frac{F_a}{F_r + 2M/D_{pw}} \leq 1.5$

$X = 0.67, Y = 0.67$, for $\frac{F_a}{F_r + 2M/D_{pw}} > 1.5$

In the equation (1), P is the dynamic equivalent load; F_r is the radial load; F_a is the axial load; the unit of P, F_r and F_a is Newton (N) or kilogram force (kgf); M is the torque in N · mm or kgf · mm; X and Y are the radial load coefficient and the axial load coefficient; the pitch circle diameter, $D_{pw} = (\text{inside diameter of bearing, } d + \text{outside diameter of bearing, } D)/2$, and the unit is mm. °

Basic Rating Life, L

The basic rating life means 90% of bearings are not failed after operating for a certain revolutions under the same operating condition. The equation (2) can be used to calculate the basic rating life under a constant load and a constant revolution:

$$L = \left(\frac{C}{P} \right)^{\frac{10}{3}} \dots \dots \dots (2)$$

In the equation (2), L is the basic rating life of bearing in 10^6 revolutions; P is the dynamic equivalent load; C is the basic dynamic rating load; and the unit of P and C should be the same in Newton (N) or kilogram force (kgf).

Static Equivalent Load, P₀

When the bearing is statically acted by the radial load, axial load and torque, the permanent deformation will

be formed at the contact place of the rolling body and the track. This load can be assumed as the static equivalent load, which can be calculated by the equation (3):

$$P_0 = F_r + \frac{2M}{D_{pw}} + 0.44 F_a \dots\dots\dots (3)$$

In the equation (3), P_0 is the static equivalent load; F_r is the radial load; F_a is the axial load; the unit of P_0 , F_r and F_a should be the same in N or kgf; M is the torque in $N \cdot mm$ or $kgf \cdot mm$, but the unit should be coordinated to P_0 , F_r and F_a ; the pitch circle diameter, $D_{pw} = (\text{inside diameter of bearing, } d + \text{outside diameter of bearing, } D)/2$, and the unit is mm.

Safety Factor, f_s

The safety factor (f_s) is mainly determined by the basic static rating load (C_0) and the static equivalent load (P_0), as shown in the equation (4). The relationship of bearing operation condition and the suggested safety factor is shown in Table 9:

$$f_s = \left(\frac{C_0}{P_0} \right) \dots\dots\dots (4)$$

where C_0 and P_0 are the basic static rating load and the static equivalent load, and the unit should be the same in N or kgf.

Table 9 Operation condition and the suggested safety factor

Operation condition	Safety factor (f_s)
Standard operation	≥ 1.5
Bearing with vibrating load	≥ 2
High rotation and high accuracy	≥ 3

Example for the calculation of the basic rating life and the safety factor

Bearing: CRBA 15025 WW

Inside diameter $d = 150$ mm	$W_1 = 800$ N
Outside diameter $D = 210$ mm	$W_2 = 2200$ N
Pitch circle diameter, $D_{pw} = 180$ mm	
Basic dynamic rating load $C = 73100$ N	$F_r = 3000$ N
Basic static rating load $C_0 = 131900$ N	$L = 800$ mm

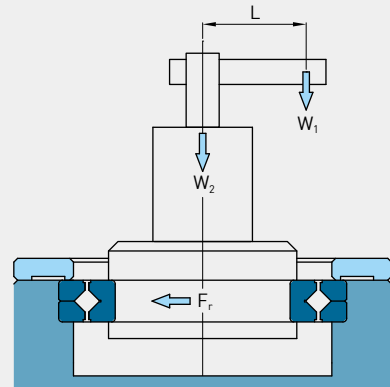

Calculation:

Radial load: $F_r = 3000$ N

Axial load: $F_a = W_1 + W_2 = 800 + 2200 = 3000$ N

Torque: $M = W_1 \times L = 800 \times 800 = 640000$ N · mm

Pitch circle diameter: $D_{pw} = (d + D)/2 = (150 + 210)/2 = 180$ mm

$$\frac{F_a}{F_r + 2M/D_{pw}} = \frac{3000}{3000 + 2 \times 640000 / 180} \approx 0.297 < 1.5$$

Radial load coefficient, $X = 1$, axial load coefficient, $Y = 0.45$

Dynamic equivalent load:

$$P = X \left(F_r + \frac{2M}{D_{pw}} \right) + Y F_a = 1 \times \left(3000 + \frac{2 \times 640000}{180} \right) + 0.45 \times 3000 \approx 11461$$
 N

Static equivalent load:

$$P_0 = F_r + \frac{2M}{D_{pw}} + 0.44 F_a = 3000 + \frac{2 \times 640000}{180} + 0.44 \times 3000 \approx 11431$$
 N

$$\text{Basic rating life: } L = \left(\frac{C}{P} \right)^{\frac{10}{3}} = \left(\frac{73100}{11461} \right)^{\frac{10}{3}} \approx 481 (x 10^6 \text{ rev.})$$

$$\text{Safety factor: } f_s = \left(\frac{C_0}{P_0} \right) = \frac{131900}{11431} \approx 11.5$$

Note: 1. If the axial load (Fa), the radial load (Fr) and the torque (M) are applied on the bearing, no direction should be considered for these three loads because they are all positive value.

2. 1 N = 0.102 kgf = 0.2248 lbs; 1 mm = 0.03937 inch.

Fitness

Table 10 Fitness for suggested dimension of axle and bearing housing

clearance type	Load condition		Suggested fitness status	
			shaft	Bearing housing
C8	Rotation load of inner ring	Common load	h5 (0~5 μm of interference match)	H6 (0~10 μm of interference match)
		High vibrating load		
	Rotation load of outer ring	Common load	g5 (0~10 μm of interference match)	JS6 or J6 (0~5 μm of interference match)
		High vibrating load		
C1	Rotation load of inner ring	Common load	js5 or j5	H6
		High vibrating load	k5	JS6 or J6
	Rotation load of outer ring	Common load	g5	JS6 or J6
		High vibrating load	h5	K6

Note: The fitness in parentheses should be used for the bearing with higher pre-load.

Example 1:

The clearance type is C8, the inner ring is rotated (bearing inner ring is rotated, outer ring is not rotated), the split outer ring type (CRBA) of Crossed Roller Bearing is suggested.

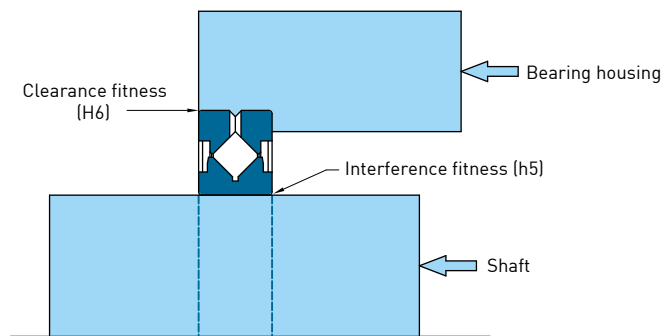

Example 2:

The clearance type is C8, the inner ring is rotated (bearing outer ring is rotated, inner ring is not rotated), the split outer ring type (CRBB) of Crossed Roller Bearing is suggested.

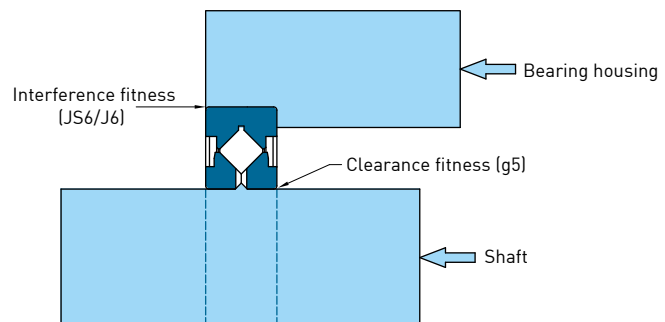

Fixing way and design of housing and mounting disc

The housing and the mounting disc are parts for supporting and clamping the bearing. Because the Crossed Roller Bearing has thin wall, it is necessary to consider the rigidity of housing and mounting disc. When the split type of bearing is used, if the rigidity of housing and mounting disc is insufficient, the bearing will be deformed due to uneven pressure of inner ring and outer ring, so that the performance of bearing will be reduced and unsteady. In order to prevent the occurrence of this condition, the housing and mounting disc should be designed as follows:

Housing: The wall thickness of housing, T, can be calculated by the equation (5):

$$T > \frac{D-d}{2} \times 0.6 \dots \dots \dots (5)$$

In the equation (5), D is the outside diameter of outer ring; d is the inside diameter of inner ring. The steel is used for the bracket in the equation. If the aluminum or aluminum alloy is used, it should be adjusted in accordance with the property of material.

In addition, the screw holes can be added for the housing. When the bearing should be taken out from the housing, the bolt can be used to eject the bearing from the housing for ease removal without damaging the bearing. As for the dimension of side panel, please refer to relevant dimension shown in the bearing specification.

Mounting disc: The wall thickness (E) of mounting disc and the clearance (S) of mounting disc can be calculated by the equation (6).

$$E = B \times 0.5 \sim B \times 1.2$$

$$H = B \begin{matrix} +0 \\ -0.1 \end{matrix} \dots\dots\dots (6)$$

$$S = 0.5\text{mm}$$

It can refer to Table 11 for the number of sink bolts of outer ring mounting disc. If the inner ring mounting disc is designed, the inside diameter of bearing inner ring can be substituted into Table 11 for calculating the number of sink bolts. If medium hard steel is used for the housing or mounting disc, the torque value of bolt shown in Table 12 can be used for tightening the bolt in mounting disc. In addition, when the mounting disc is installed, the dimension tolerance of parts should be considered for closely pressing the mounting disc and the inner and outer ring. A section difference of mounting disc should be designed for adjusting the tightening force. As for the mounting disc made up of steel, it had better to adjust to 0.02~0.05mm. It should be larger for different to the shaft diameter and load for providing sufficient locking rigidity.

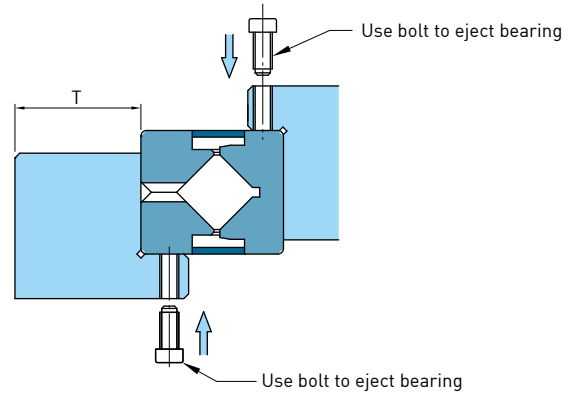
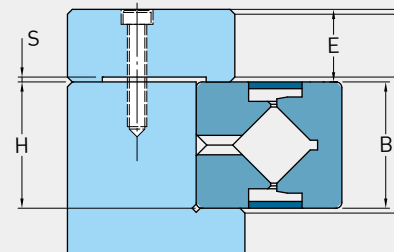

Table 11 Bolt number and bolt dimension

O. D. of outer ring, D (mm)	Bolt number	Bolt specification
100 below	8 (Included) more	M3~M5
100~200	12 (Included) more	M4~M8
200~500	16 (Included) more	M5~M12
500 above	24 (Included) more	M6~

Table 12 Torque value of bolt

Bolt specification	Torque value (N·m)	Bolt specification	Torque value (N·m)
M3	2	M10	70
M4	4	M12	120
M5	9	M16	200
M6	14	M20	390
M8	30	M22	530



Installing steps

Upon installing the Crossed Roller Bearing, please follow:

1. Inspect parts before installing: Clean bearing housing, main shaft or other parts to remove dirt or grease.
2. Place the bearing into bearing housing and shaft: As for the design of clearance match, keep the bearing horizontally and insert the bearing into bearing housing or shaft. If it is hard for the installation, use a rubber hammer to slightly hit every part of bearing, so that the bearing can be inserted into bearing housing or shaft easily. Finally, the sound change is used to confirm the match of bearing and basic face. As for the design of interference match, use heating or cooling way to expand or shrink the parts for ease of installation. But the bearing temperature should not be over 80°C . In addition, it has to pay attention to the hitting force to the bearing, if the force is too large, the bearing may be damaged. If the inner ring or outer ring of split bearing is acentric, the bolts of inner ring or outer ring can be loosen slightly and then, turn the outer ring or inner ring upon placing the bearing into bearing housing, So, the bearing can be placed into bearing housing smoothly.

3. Install mounting disc: Place the mounting disc on the bearing, and align the screw hole for locking the bolt.
Tighten the bolts diagonally as follow diagram. Then tighten all bolts in sections. Prevent to tighten all bolts at the first time.

Other description

Description of lubrication

1. There is HIWIN G04 lubricant (#2 Li soap grease) in all Crossed Roller Bearings. So, the delivered bearing can be used directed. If the lubrication is insufficient, the friction resistance will be increased and the service life will be reduced. The lubricant should be supplemented for the open bearing periodically, such as 1 ~ 6 months. The lubricating frequency depends on the use condition. The lubricant should be distributed evenly inside the bearing.
2. Prevent to mix different lubricants.
3. If the bearing is used at high vibration, clean room, vacuum, high temperature or low temperature, the specific lubricant should be used, please contact with HIWIN.

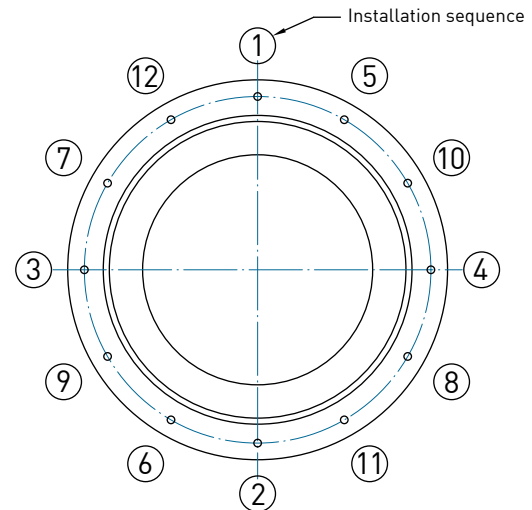

Description of allowable revolution

The allowable DN value of Crossed Roller Bearing is 60000 mm•rpm. If CRBB 05013 WW C8 P5 bearing is used, the roller PCD of this bearing is about 65 mm. So the allowable revolution is about $60000/65 = 923$ rpm

Use cautions

1. The normal use temperature of bearing is 10 ~ 80 °C . If it is over this temperature range, please contact with HIWIN.
2. If foreign substance enters into inside structure of bearing, the rotation route of roller may be damaged, even the bearing may fail. So, prevent the foreign substance enters into inside structure of bearing.
3. If foreign substance enters into inside structure of bearing, please clean it then refill the lubricant.
4. Please do not remove the bolt and nut of split bearing. Upon installing, please do not apply force to the bolt and nut.

CRBA Product Specification

1. Split outer ring type (CRBA), the bore diameter is 20 ~ 300 mm, sealed and open type.

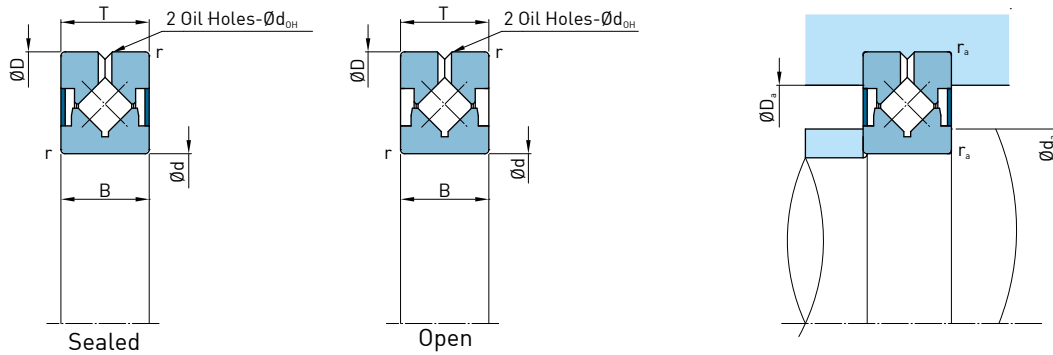

Dimensions (mm)			Bearing No.	Oil holes, d_{OH} (mm)	Basic loading rates (kN)		Abutment and fillet dimensions (mm)		
Inner diameter (d)	Outer diameter (D)	Width (B, T)			Dynamic load, C	Static load, C_0	d_a	D_a	r_a (max)
20	36	8	CRBA 02008	1.5	4.1	4	22.9	30.8	0.6
25	41	8	CRBA 02508	1.5	4.5	4.8	27.9	35.8	0.6
30	55	10	CRBA 03010	1.5	8.2	9.2	35	46.8	0.6
35	60	10	CRBA 03510	1.5	8.5	10	40	51.8	0.6
40	65	10	CRBA 04010	1.5	9.3	11.6	45	56.8	0.6
45	70	10	CRBA 04510	1.5	9.6	12.5	50	61.8	0.6
50	80	13	CRBA 05013	2	18.9	23.4	57.2	72	0.6
60	90	13	CRBA 06013	2	20.3	27	67	82	0.6
70	100	13	CRBA 07013	2	21.7	30.6	77	92	0.6
80	110	13	CRBA 08013	2	22.8	34.2	87	102	0.6
80	120	16	CRBA 08016	2.5	30.2	44.8	92	109	0.6
90	130	16	CRBA 09016	2.5	30.8	47.4	104	120	1
90	140	20	CRBA 09020	2.5	39.7	60.2	104	120	1
100	140	16	CRBA 10016	2.5	32.5	52.3	112	129	1
100	150	20	CRBA 10020	2.5	40.4	63.6	117	132	1
110	160	20	CRBA 11020	2.5	42.7	70.2	126	143	1
120	150	16	CRBA 12016	2.5	28.1	50.3	126	143	1
120	170	20	CRBA 12020	2.5	44.9	76.9	136	153	1.5
120	180	25	CRBA 12025	2.5	66.3	109	138	158	1.5
130	190	25	CRBA 13025	2.5	67.8	114.8	148	168	1.5
140	200	25	CRBA 14025	2.5	69.5	120.6	161	178	1.5
150	210	25	CRBA 15025	2.5	73.1	131.9	168	188	1.5
150	230	30	CRBA 15030	3	114.3	187.3	181	198	1.5
160	220	25	CRBA 16025	2.5	74.5	137.7	181	198	1.5
170	220	20	CRBA 17020	2.5	52.3	103.6	183	203	1.5
180	240	25	CRBA 18025	2.5	79.6	154.8	198	218	1.5
190	240	25	CRBA 19025	2.5	54.5	113.6	203	223	1
200	260	25	CRBA 20025	2.5	82.3	166.4	218	238	2
200	280	30	CRBA 20030	3	122.9	242	231	248	2
200	295	35	CRBA 20035	3	155.9	277.4	238	258	2
220	280	25	CRBA 22025	2.5	86.3	183.5	237	259	2
240	300	25	CRBA 24025	2.5	90.5	200.6	257	279	2
250	310	25	CRBA 25025	2.5	91.6	206.4	267	289	2
250	330	30	CRBA 25030	3	142	286.2	280	299	2
250	355	40	CRBA 25040	4	207	391.8	289	311	2
300	360	25	CRBA 30025	2.5	100.6	246.5	317	339	2.5
300	395	35	CRBA 30035	3	191.6	407.8	337	359	2.5
300	405	40	CRBA 30040	4	227	465.8	339	361	2.5

Note: 1. The basic loading rates were referred to ISO76 / ISO281.
2. If any requirement of dimension, please contact with HIWIN.

CRBB Product Specification

2. Split inner ring type (CRBB), the bore diameter is 30 ~ 300 mm, sealed and open type.

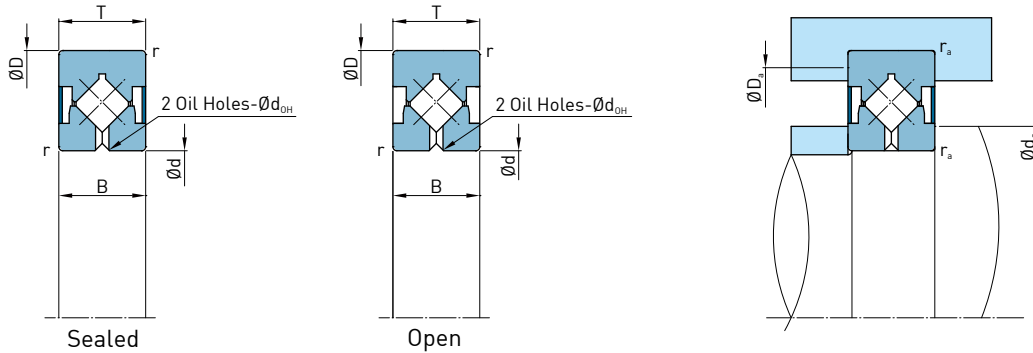

Dimensions (mm)			Bearing No.	Oil holes, d_{OH} (mm)	Basic loading rates (kN)		Abutment and fillet dimensions (mm)		
Inner diameter (d)	Outer diameter (D)	Width (B, T)			Dynamic load, C	Static load, C_0	d_a	D_a	r_a (max)
30	55	10	CRBB 03010	1.5	8.2	9.2	35	46.8	0.6
35	60	10	CRBB 03510	1.5	8.5	10	40	51.8	0.6
40	65	10	CRBB 04010	1.5	9.3	11.6	45	56.8	0.6
45	70	10	CRBB 04510	1.5	9.6	12.5	50	61.8	0.6
50	80	13	CRBB 05013	2	18.9	23.4	57.2	72	0.6
60	90	13	CRBB 06013	2	20.3	27	67	82	0.6
70	100	13	CRBB 07013	2	21.7	30.6	77	92	0.6
80	110	13	CRBB 08013	2	22.8	34.2	87	102	0.6
80	120	16	CRBB 08016	2.5	30.2	44.8	92	109	0.6
90	130	16	CRBB 09016	2.5	30.8	47.4	104	120	1
90	140	20	CRBB 09020	2.5	39.7	60.2	104	120	1
100	140	16	CRBB 10016	2.5	32.5	52.3	112	129	1
100	150	20	CRBB 10020	2.5	40.4	63.6	117	132	1
110	160	20	CRBB 11020	2.5	42.7	70.2	126	143	1
120	150	16	CRBB 12016	2.5	28.1	50.3	126	143	1
120	170	20	CRBB 12020	2.5	44.9	76.9	136	153	1.5
120	180	25	CRBB 12025	2.5	66.3	109	138	158	1.5
130	190	25	CRBB 13025	2.5	67.8	114.8	148	168	1.5
140	200	25	CRBB 14025	2.5	69.5	120.6	161	178	1.5
150	210	25	CRBB 15025	2.5	73.1	131.9	168	188	1.5
150	230	30	CRBB 15030	3	114.3	187.3	181	198	1.5
160	220	25	CRBB 16025	2.5	74.5	137.7	181	198	1.5
170	220	20	CRBB 17020	2.5	52.3	103.6	183	203	1.5
180	240	25	CRBB 18025	2.5	79.6	154.8	198	218	1.5
190	240	25	CRBB 19025	2.5	54.5	113.6	203	223	1
200	260	25	CRBB 20025	2.5	82.3	166.4	218	238	2
200	280	30	CRBB 20030	3	122.9	242	231	248	2
200	295	35	CRBB 20035	3	155.9	277.4	238	258	2
220	280	25	CRBB 22025	2.5	86.3	183.5	237	259	2
240	300	25	CRBB 24025	2.5	90.5	200.6	257	279	2
250	310	25	CRBB 25025	2.5	91.6	206.4	267	289	2
250	330	30	CRBB 25030	3	142	286.2	280	299	2
250	355	40	CRBB 25040	4	207	391.8	289	311	2
300	360	25	CRBB 30025	2.5	100.6	246.5	317	339	2.5
300	395	35	CRBB 30035	3	191.6	407.8	337	359	2.5
300	405	40	CRBB 30040	4	227	465.8	339	361	2.5

Note: 1. The basic loading rates were referred to ISO76 / ISO281.
2. If any requirement of dimension, please contact with HIWIN.

CRBC Product Specification

3. High rigidity type (CRBC), the bore diameter is 20 ~ 150 mm, sealed and open type.

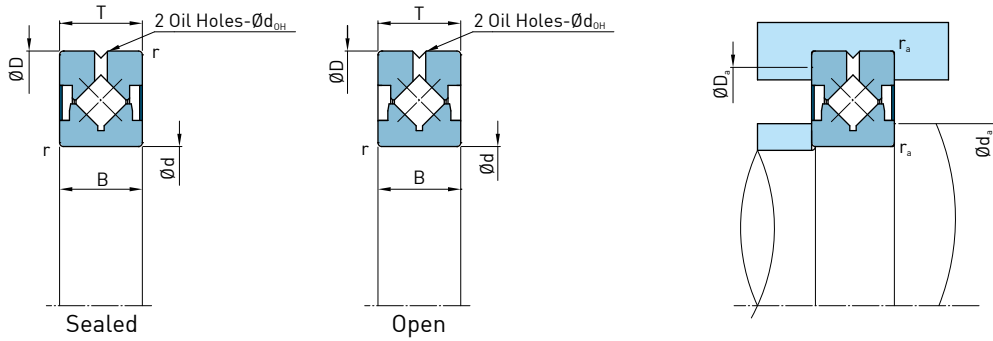

Dimensions (mm)			Bearing No.	Oil holes, d_{OH} (mm)	Basic loading rates (kN)		Abutment and fillet dimensions (mm)		
Inner diameter (d)	Outer diameter (D)	Width (B, T)			Dynamic load, C	Static load, C_0	d_a	D_a	r_a (max)
20	36	8	CRBC 02008	1.5	4.1	4	22.9	30.8	0.6
25	41	8	CRBC 02508	1.5	4.5	4.8	27.9	35.8	0.6
30	55	10	CRBC 03010	1.5	8.2	9.2	35	46.8	0.6
35	60	10	CRBC 03510	1.5	8.5	10	40	51.8	0.6
40	65	10	CRBC 04010	1.5	9.3	11.6	45	56.8	0.6
45	70	10	CRBC 04510	1.5	9.6	12.5	50	61.8	0.6
50	80	13	CRBC 05013	2	18.9	23.4	57.2	72	0.6
60	90	13	CRBC 06013	2	20.3	27	67	82	0.6
70	100	13	CRBC 07013	2	21.7	30.6	77	92	0.6
80	110	13	CRBC 08013	2	22.8	34.2	87	102	0.6
80	120	16	CRBC 08016	2.5	30.2	44.8	92	109	0.6
90	130	16	CRBC 09016	2.5	30.8	47.4	104	120	1
90	140	20	CRBC 09020	2.5	39.7	60.2	104	120	1
100	140	16	CRBC 10016	2.5	32.5	52.3	112	129	1
100	150	20	CRBC 10020	2.5	40.4	63.6	117	132	1
110	160	20	CRBC 11020	2.5	42.7	70.2	126	143	1
120	150	16	CRBC 12016	2.5	28.1	50.3	126	143	1
120	170	20	CRBC 12020	2.5	44.9	76.9	136	153	1.5
120	180	25	CRBC 12025	2.5	66.3	109	138	158	1.5
130	190	25	CRBC 13025	2.5	67.8	114.8	148	168	1.5
140	200	25	CRBC 14025	2.5	69.5	120.6	161	178	1.5
150	210	25	CRBC 15025	2.5	73.1	131.9	168	188	1.5

Note: 1. The basic loading rates were referred to ISO76 / ISO281.
2. If any requirement of dimension, please contact with HIWIN.

CRBD Product Specification

4. Split outer ring with mounting holes (CRBD), the bore diameter is 20 ~ 160 mm, sealed and open type.

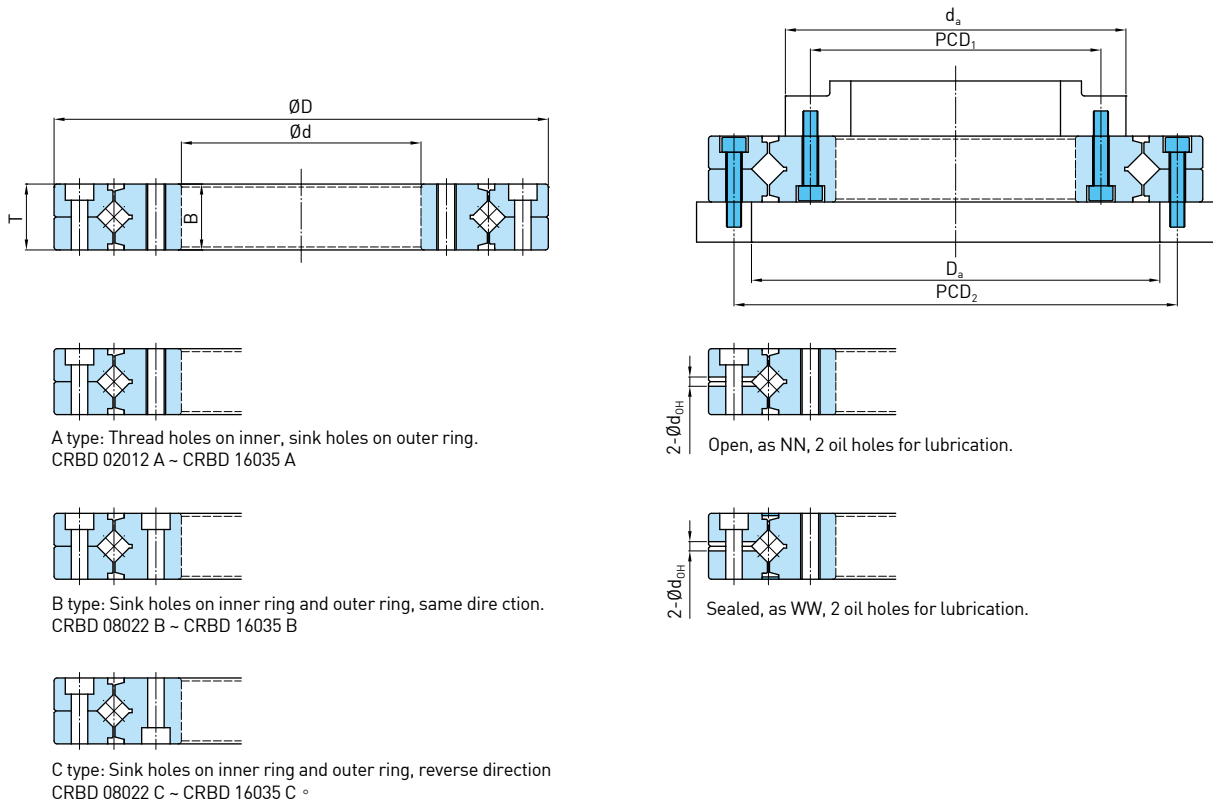

Dimensions (mm)					Bearing No.	Dimensions of mounting holes (mm)				Basic loading rates (kN)		Abutment and fillet dimensions (mm)	
Inner dia. (d)	Outer dia. (D)	Width (B, T)	Chamfer (r _{min})	Oil holes d _{OH} (mm)		Inner rings		Outer rings		Dynamic load, C	Static load, C ₀	d _a	D _a
						PCD ₁	Mounting holes	PCD ₂	Mounting holes				
20	70	12	0.6	3	CRBD 02012 A	28	6-M3 through	57	6-ø3.4 through ø6.5 counter bore depth 3.3	8.26	9.16	35	47
35	95	15	0.6	3	CRBD 03515 A	45	8-M4 through	83	8-ø4.5 through ø8 counter bore depth 4.4	18.9	23.4	57	73
55	120	15	0.6	3	CRBD 05515 A	65	8-M5 through	105	8-ø5.5 through ø9.5 counter bore depth 5.4	21.7	30.6	77	92
80	165	22	1	3	CRBD 08022 A	97	10-M5 through	148	10-ø5.5 through ø9.5 counter bore depth 5.4	40.4	63.6	117	132
					CRBD 08022 B		10-ø5.5 through ø9.5 counter bore depth 5.4						
					CRBD 08022 C		10-ø5.5 through ø9.5 counter bore depth 5.4						
90	210	25	1.5	3	CRBD 09025 A	112	12-M8 through	187	12-ø9 through ø14 counter bore depth 8.6	46	80.2	139	157
					CRBD 09025 B		12-ø9 through ø14 counter bore depth 8.6						
					CRBD 09025 C		12-ø9 through ø14 counter bore depth 8.6						
115	240	28	1.5	3	CRBD 11528 A	139	12-M8 through	217	12-ø9 through ø14 counter bore depth 8.6	73.1	131.9	168	188
					CRBD 11528 B		12-ø9 through ø14 counter bore depth 8.6						
					CRBD 11528 C		12-ø9 through ø14 counter bore depth 8.6						
160	295	35	2	6	CRBD 16035 A	184	12-M10 through	270	12-ø11 through ø17.5 counter bore depth 10.8	102	192.3	218	238
					CRBD 16035 B		12-ø11 through ø17.5 counter bore depth 10.8						
					CRBD 16035 C		12-ø11 through ø17.5 counter bore depth 10.8						

Note: 1. The basic loading rates were referred to ISO76 / ISO281.
2. If any requirement of dimension, please contact with HIWIN.

CRBE Product Specification

5. High rigidity with mounting holes (CRBE), the bore diameter is 20 ~ 210 mm, sealed and open type.

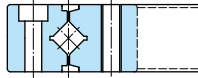
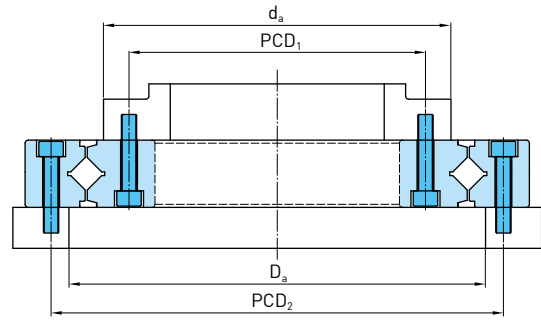
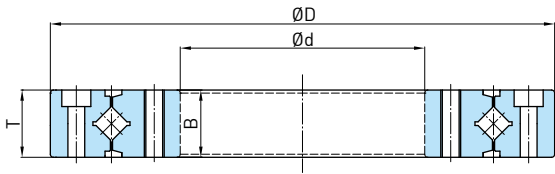

A type: Thread holes on inner ring, sink holes on outer ring.
CRBE 02012 A ~ CRBE 21040 A

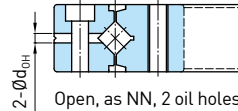

Open, as NN, 2 oil holes for lubrication.

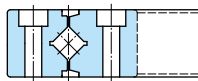

B type: Sink holes on inner ring and outer ring, same direction.
CRBE 08022 B ~ CRBE 21040 B

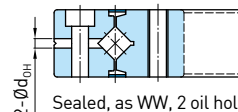

Sealed, as WW, 2 oil holes for lubrication.

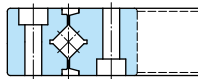

C type: Sink holes on inner ring and outer ring, reverse direction.
CRBE 08022 C ~ CRBE 21040 C

Dimensions (mm)					Bearing No.	Dimensions of mounting holes (mm)				Basic loading rates (kN)		Abutment and fillet dimensions (mm)	
Inner dia. (d)	Outer dia. (D)	Width (B, T)	Chamfer (r _{min})	Oil holes d _{OH} (mm)		Inner rings		Outer rings		Dynamic load, C	Static load, C ₀	d _a	D _a
						PCD ₁	Mounting holes	PCD ₂	Mounting holes				
20	70	12	0.6	3	CRBE 02012 A	28	6-M3 through	57	6-ø3.4 through ø6.5 counter bore depth 3.3	8.26	9.16	35	47
35	95	15	0.6	3	CRBE 03515 A	45	8-M4 through	83	8-ø4.5 through ø8 counter bore depth 4.4	18.9	23.4	57	73
55	120	15	0.6	3	CRBE 05515 A	65	8-M5 through	105	8-ø5.5 through ø9.5 counter bore depth 5.4	21.7	30.6	77	92
80	165	22	1	3	CRBE 08022 A	97	10-M5 through	148	10-ø5.5 through ø9.5 counter bore depth 5.4	40.4	63.6	117	132
					CRBE 08022 B								
					CRBE 08022 C								
90	210	25	1.5	3	CRBE 09025 A	112	12-M8 through	187	12-ø9 through ø14 counter bore depth 8.6	46	80.2	139	157
					CRBE 09025 B								
					CRBE 09025 C								
115	240	28	1.5	3	CRBE 11528 A	139	12-M8 through	217	12-ø9 through ø14 counter bore depth 8.6	73.1	131.9	168	188
					CRBE 11528 B								
					CRBE 11528 C								
160	295	35	2	6	CRBE 16035 A	184	12-M10 through	270	12-ø11 through ø17.5 counter bore depth 10.8	102	192.3	218	238
					CRBE 16035 B								
					CRBE 16035 C								
210	380	40	2.5	6	CRBE 21040 A	240	16-M12 through	350	16-ø14 through ø20 counter bore depth 13	142	286.2	277	299
					CRBE 21040 B								
					CRBE 21040 C								

Note: 1. The basic loading rates were referred to ISO76 / ISO281.
2. If any requirement of dimension, please contact with HIWIN.

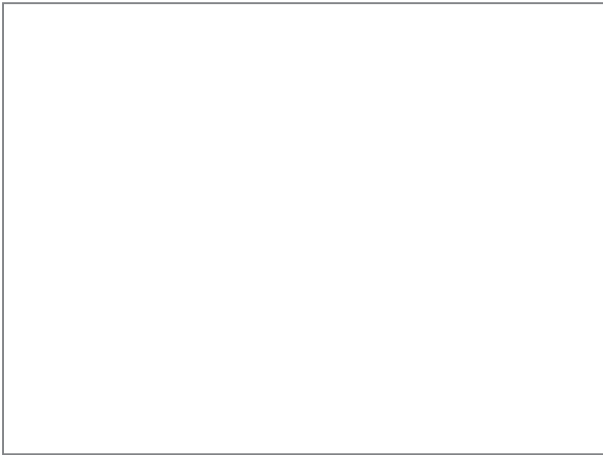

HIWIN TECHNOLOGIES CORP.

No. 46, 37th Road,
Taichung Industrial Park
Taichung 40768, TAIWAN
Tel: +886-4-23594510
Fax: +886-4-23594420
www.hiwin.com.tw
business@mail.hiwin.com.tw

HIWIN USA

•CHICAGO
1400 Madeline Lane
Elgin, IL 60124, U.S.A.
Tel : +1-847-8272270
Fax: +1-847-8272291
www.hiwin.com
info@hiwin.com

•SILICON VALLEY

Tel : +1-510-4380871
Fax: +1-510-4380873

HIWIN JAPAN

•KOBE
3F. Sannomiya-Chuo Bldg.
4-2-20 Goko-Dori. Chuo-Ku
KOBE 651-0087, JAPAN
Tel: +81-78-2625413
Fax: +81-78-2625686
www.hiwin.co.jp
info@hiwin.co.jp

HIWIN GmbH

Brücklesbünd 2, D-77654
Offenburg, GERMANY
Tel : +49-781-93278-0
Fax: +49-781-93278-90
www.hiwin.de
www.hiwin.eu
info@hiwin.de

HIWIN SCHWEIZ

Schachenstrasse 80
CH-8645 Jona,
SWITZERLAND
Tel : +41-55-2250025
Fax: +41-55-2250020
www.hiwin.ch
info@hiwin.ch

HIWIN S.R.O.

Kastanova 34
CZ 62000 Brno,
CZECH REPUBLIC
Tel : +420-548-528238
Fax: +420-548-220233
www.hiwin.cz
info@hiwin.cz

HIWIN FRANCE

24 ZI N 1 EST-BP 78
F-61302 L'Aigle Cedex
Tel : +33(0)233341115
Fax: +33(0)233347379
www.hiwin.fr
info@hiwin.fr

Mega-Fabs Motion Systems, Ltd.

13 Hayetzira St. Industrial Park,
P.O.Box 540, Yokneam 20692, Israel
Tel : +972-4-9891050
Fax: +972-4-9891080
www.mega-fabs.com
mega-f@mega-f.co.il

Matrix Machine Tool (COVENTRY) LIMITED

A2 Earplace Business Park
Fletchamstead Highway
Coventry CV4 9XL
United Kingdom
Tel: +44(0)2476718886
Fax: +44(0)2476678899
www.matrix-machine.com
sales@matrix-machine.com