

ELEMENTY MOCUJĄCE do siłowników pneumatycznych D12 ÷ D25 zgodnych z ISO 6432

ZASTOSOWANIE

Elementy mocujące służą do montażu siłowników w maszynach i urządzeniach zapewniając ich prawidłową zabudowę.

KOŃCÓWKA PROSTA Z PRZEGUBEM KULOWYM (ISO 8139)

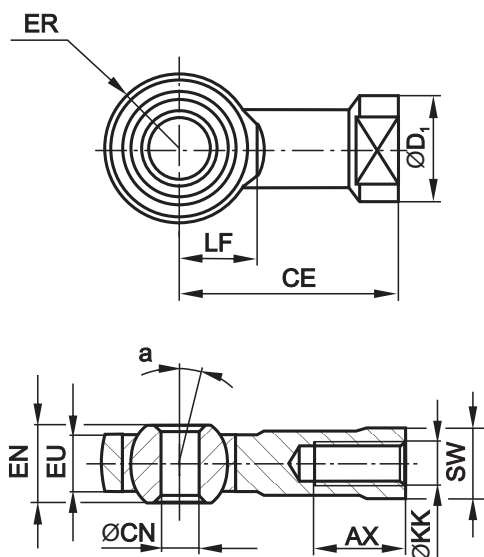

Średnica siłownika [mm]	Wymiary [mm]											Numer zamówieniowy
	AX	CE	CN _{H8}	D ₁	EU	EN	ER	OKK	LF	SW	α°	
12,16	12	30	6	13	6.8	9	10	M6	11	11	13	10.014B.06.
20	16	36	8	16	9	12	12	M8	13	14	13	10.014C.06.
25	20	43	10	19	10.5	14	14	M10×1.25	15	17	13	10.014E.06.

SPOSÓB ZAMAWIANIA

W zamówieniu należy podać: nazwę elementu, średnicę siłownika, numer zamówieniowy oraz ilość sztuk np.:

Końcówka prosta D16 ISO nr 10.007A.02. 3 szt.

KOŃCÓWKA WIDEŁKOWA (ISO 8140)

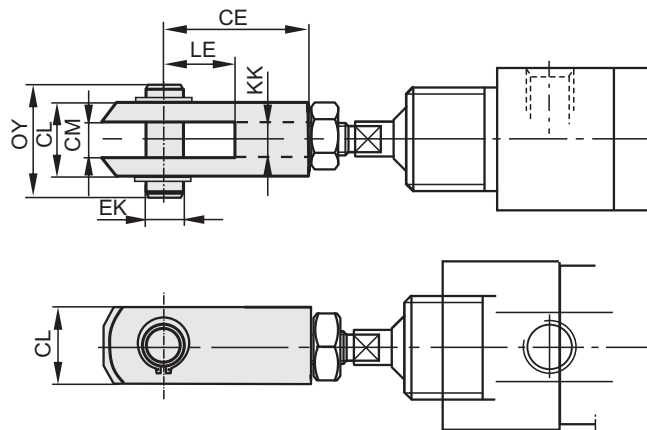

Średnica siłownika [mm]	Wymiary [mm]							Numer zamówieniowy
	CE	CL	CM	EK	LE	OY	KK	
12	24	12	6	6	12	17	M6	10.007A.02.
16	32	16	8	8	16	21	M8	10.007C.02.
25	40	20	10	10	20	25	M10x1.25	10.007D.02.

NAKRĘTKA

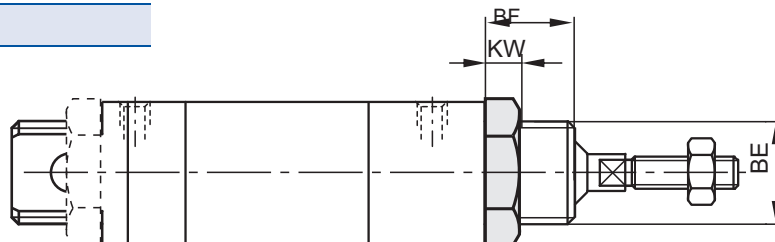

Średnica siłownika [mm]	Wymiary [mm]				Numer zamówieniowy
	O BE	BF	KW	KV	
12	M16 × 1.5	15	6	22	10.007A.05.
16	M22 × 1.5	19	7	30	10.007C.05.

ŁAPA

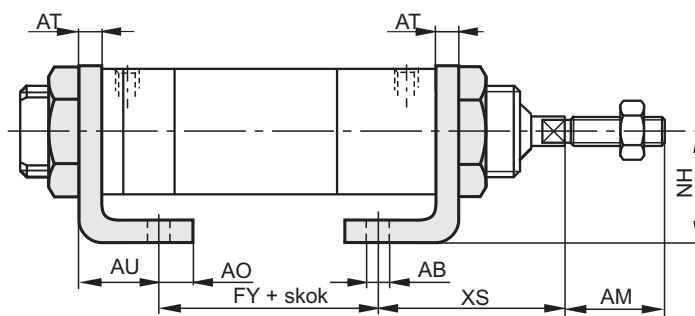
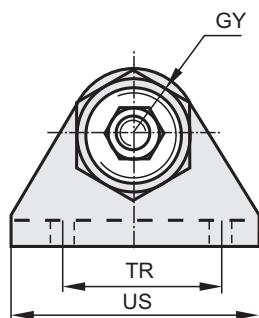
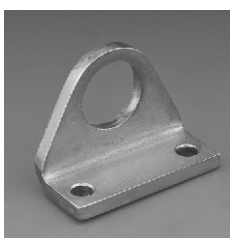

Średnica siłownika [mm]	Wymiary [mm]											Numer zamówieniowy
	OABH13	AM	AO	AT	AU	FY	GY	NH	TR	US	XS	
12	5.5	16	6	4	14	30	12	20	32	44	32	10.007A.03.
16						35						
20	6.6	20	7	5	17	43	16	25	40	54	36	10.007C.03.
25						47						

Uwaga: Komplet stanowi łąpa wraz z nakrętką

KOŁNIERZ

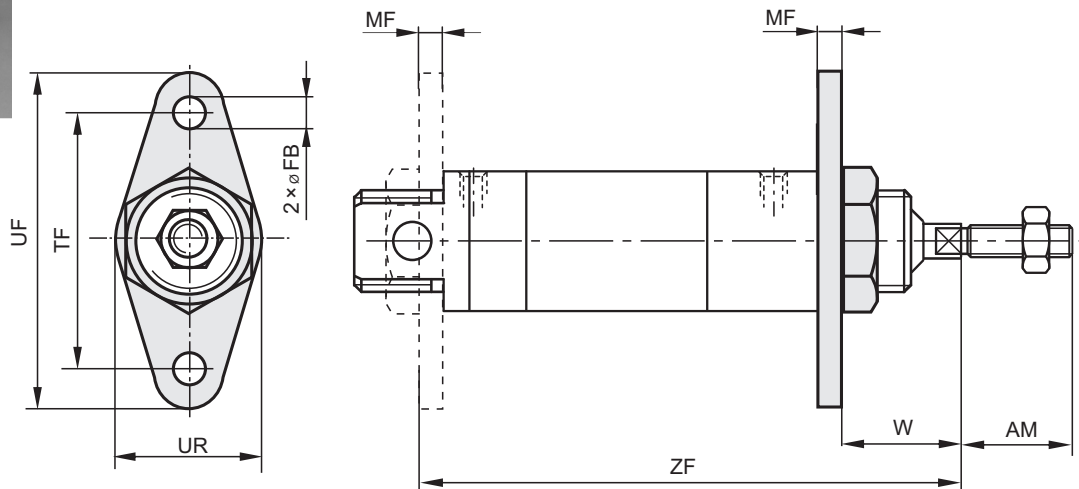

Średnica siłownika [mm]	Wymiary [mm]								Numer zamówieniowy
	AM	ØFB _{H13}	MF	TF	UF	UR	W	ZF	
12	16	5.5	4	40	52	28	18	76	10.007A.04.
16								81	
20	22	6.6	5	50	64	38	19	96	10.007C.04.
25								104	

Uwaga: Komplet stanowi kołnierz wraz z nakrętką

UCHO ZE SWORZNIEM

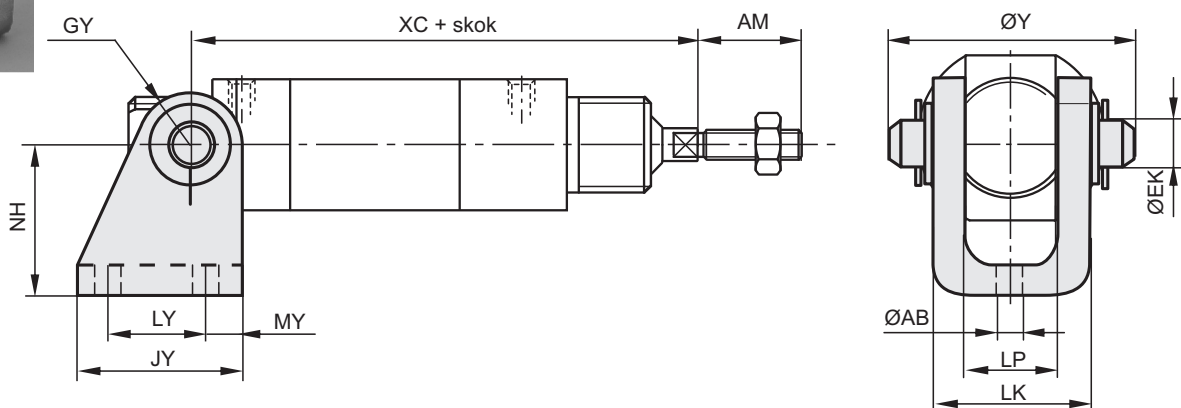

Średnica siłownika [mm]	Wymiary [mm]												Numer zamówieniowy
	AM	ØAB _{H13}	ØEK _{h11}	GY	JY	LK	LP	LY	MY	NH	OY	XC	
12	16	5.5	6	7	25	18.2	12.2	16	4.5	20	24,5	75	10.007A.01.
16										27*		82	
20	22	6.6	8	10	32	24.2	16.2	20	6	25	30,5	95	10.007C.01.
25										30*		104	