

WIDEŁKI

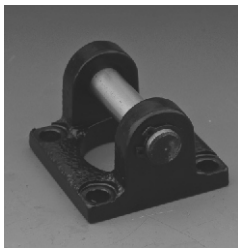

Średnica siłownika [mm]	Wymiary [mm]											Wykonanie materiałowe	Numer zamówieniowy
	A	CB	OCD	OD	OD1	E	MR	FL	TG	XD	Y		
40	70	33	12	7	32	52	12	24	40	134	60	żeliwo	10.004F.02.
	70	33	12	7	32	52	12	24	40	134	60	odlew ciśnieniowy z Al	10.004F.02.A
50	70	33	12	9	32	65	12	26	49	136	73	żeliwo	10.004G.02.
	70	33	12	9	32	65	12	26	49	136	73	odlew ciśnieniowy z Al	10.004G.02.A
63	85	47	16	9	45	75	16	30	59	155	83	żeliwo	10.004H.02.
	85	47	16	9	45	75	16	30	59	155	83	odlew ciśnieniowy z Al	10.004H.02.A
80	85	47	16	11	45	95	16	32	75	157	103	żeliwo	10.004J.02.
	85	47	16	11	45	95	16	32	75	157	103	odlew ciśnieniowy z Al	10.004J.02.A
100	110	57	20	11	55	115	20	37	90	182	123	żeliwo	10.004K.02.
	110	57	20	11	55	115	20	37	90	182	123	odlew ciśnieniowy z Al	10.004K.02.A
125	110	57	20	14	55	140	20	41	110	186	148	żeliwo	10.004L.02.
	110	57	20	14	55	140	20	41	110	186	148	odlew ciśnieniowy z Al	10.004L.02.A
160	135	72	25	18	65	180	25	55	140	235	188	żeliwo	10.004M.02.
	135	72	25	18	65	180	25	55	140	235	188	odlew ciśnieniowy z Al	10.004M.02.A
200	135	72	25	18	65	220	25	55	175	235	188	żeliwo	10.004N.02.
	135	72	25	18	65	220	25	55	175	235	188	odlew ciśnieniowy z Al	10.004N.02.A

UCHO PROSTE KOMPLETNE

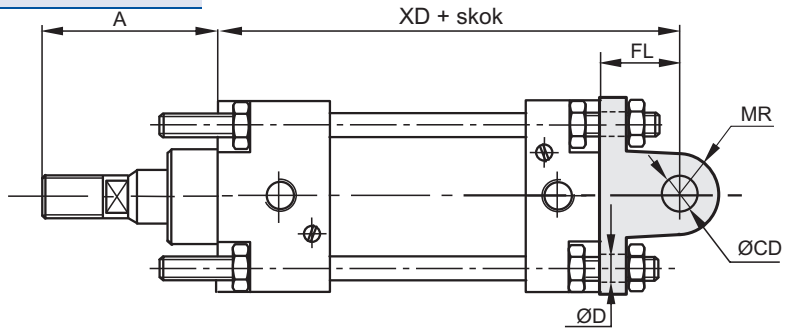
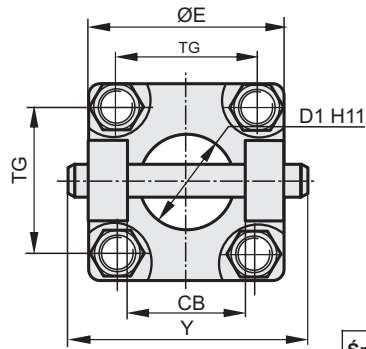
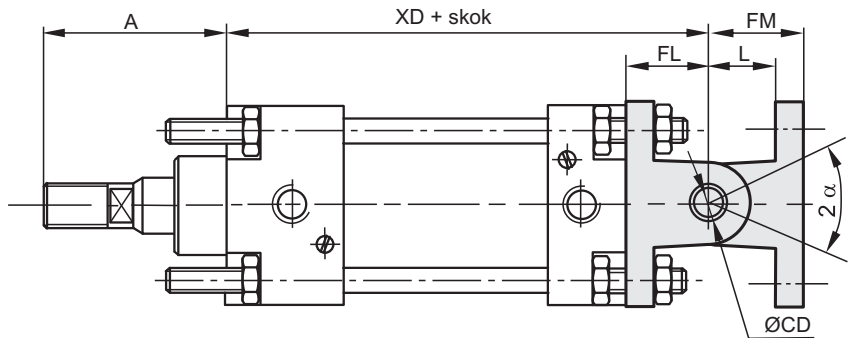
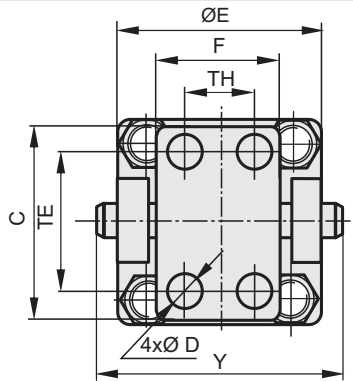

Średnica siłownika [mm]	Wymiary [mm]														Wykonanie materiałowe	Numer zamówieniowy
	A	OCD	C	OD	E	F	FL	FM	L	TE	TH	XD	Y	α		
40	70	12	52	7	52	32	24	26	16	38	16	134	60	50	żeliwo	10.004F.01.
	70	12	52	7	52	32	24	26	16	38	16	134	60	50	odlew ciśnieniowy z Al	10.004F.01.A
50	70	12	52	9	65	32	26	26	16	38	16	136	73	60	żeliwo	10.004G.01.
	70	12	52	9	65	32	26	26	16	38	16	136	73	60	odlew ciśnieniowy z Al	10.004G.01.A
63	85	16	76	9	75	46	30	34	20	54	25	155	83	60	żeliwo	10.004H.01.
	85	16	76	9	75	46	30	34	20	54	25	155	83	60	odlew ciśnieniowy z Al	10.004H.01.A
80	85	16	76	11	95	46	32	34	20	54	25	157	103	60	żeliwo	10.004J.01.
	85	16	76	11	95	46	32	34	20	54	25	157	103	60	odlew ciśnieniowy z Al	10.004J.01.A
100	110	20	115	11	115	56	37	41	25	90	32	182	123	60	żeliwo	10.004K.01.
	110	20	115	11	115	56	37	41	25	90	32	182	123	60	odlew ciśnieniowy z Al	10.004K.01.A
125	110	20	115	14	140	56	41	41	25	90	32	186	148	60	żeliwo	10.004L.01.
	110	20	115	14	140	56	41	41	25	90	32	186	148	60	odlew ciśnieniowy z Al	10.004L.01.A
160	135	25	180	18	180	71	55	55	35	150	43	235	188	60	żeliwo	10.004M.01.
	135	25	180	18	220	71	55	55	35	150	43	235	288	60	odlew ciśnieniowy z Al	10.004N.01.A
200	135	25	180	18	220	71	55	55	35	150	43	235	288	60	żeliwo	10.004N.01.
	135	25	180	18	220	71	55	55	35	150	43	235	288	60	odlew ciśnieniowy z Al	10.004N.01.A

ELEMENTY MOCUJĄCE do siłowników pneumatycznych D32 ÷ D200 Seria CNOMO

ZASTOSOWANIE

Elementy mocujące służą do montażu siłowników w maszynach i urządzeniach zapewniając ich prawidłową zabudowę.

KOŃCÓWKA PROSTA Z PRZĘGUBEM KULOWYM (ISO 8139)

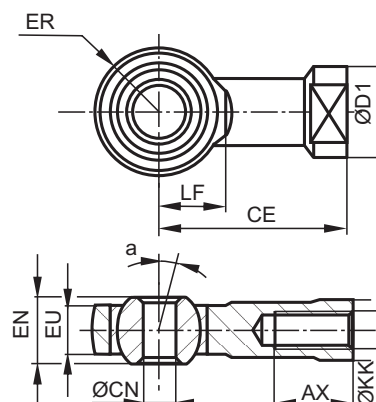

Średnica siłownika [mm]	Wymiary [mm]											Numer zamówieniowy
	AX	CE	CN	D ₁	EU	EN	ER	OKK	LF	SW	α°	
40 , 50	28	64	16	27	15	21	21	M16 × 1.5	22	22	13	10.014H.06.
63 , 80	33	77	20	34	18	25	25	M20 × 1.5	26	30	15	10.014K.06.
100 , 125	51	110	30	50	25	37	35	M27 × 2	36	41	15	10.014L.06.
160 , 200	56	125	35	58	28	43	40	M36 × 2	41	50	15	10.014N.06.

KOŃCÓWKA PROSTA

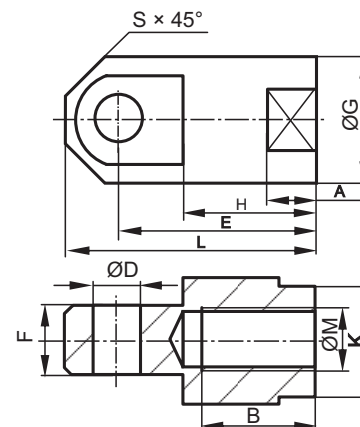

Średnica siłownika [mm]	Wymiary [mm]											Numer zamówieniowy
	A	B	φD	E	F	OG	H	K	L	OM	S	
40 , 50	12	30	12	51	18	32	34	27	64	M16×1.5	8	10.004G.06.
63 , 80	16	36	16	63	22	35	41	30	80	M20×1.5	10	10.004J.06.
100 , 125	20	50	20	85	30	45	58	36	105	M27×2	12	10.004L.06.
160 , 200	25	70	25	115	40	60	81	50	140	M36×2	17.5	10.004N.06.

SPOSÓB ZAMAWIANIA

W zamówieniu należy podać: nazwę elementu, średnicę siłownika, numer zamówieniowy oraz ilość sztuk np.: **Końcówka widelkowa D50 nr 10.004G.07. 5 szt.**

UWAGA: elementy mocujące sprzedawane są bez elementów złącznych (śrub) służących do ich zamocowania do siłowników.

KOŃCÓWKA WIDŁAKOWA

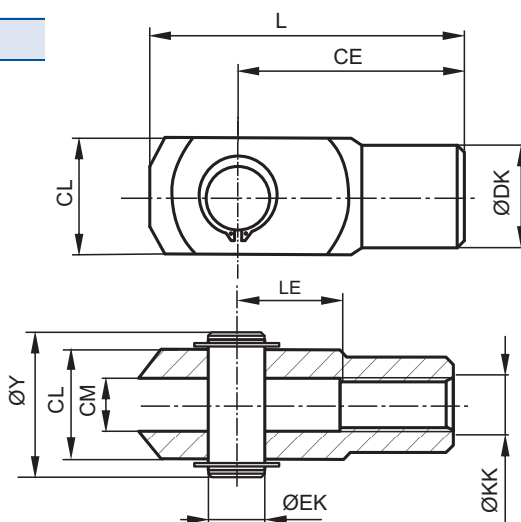

Średnica siłownika [mm]	Wymiary [mm]									Numer zamówieniowy	
	CE	CL	CM	ODK	OEK	L	LE	O KK	OY	W komplecie ze sworzniem	Bez sworznia
40 , 50	51	34	18	30	12	64	19	M16×1.5	42	10.004G.08.	10.004G.07.
63 , 80	63	43	22	40	16	80	23	M20×1.5	52	10.004J.08.	10.004J.07.
100 , 125	85	58	30	54	20	105	30	M27×2	68	10.004L.08.	10.004L.07.
160 , 200	115	77.5	40	72	25	140	40	M36×2	88	10.004N.08.	10.004N.07.

JARZMO

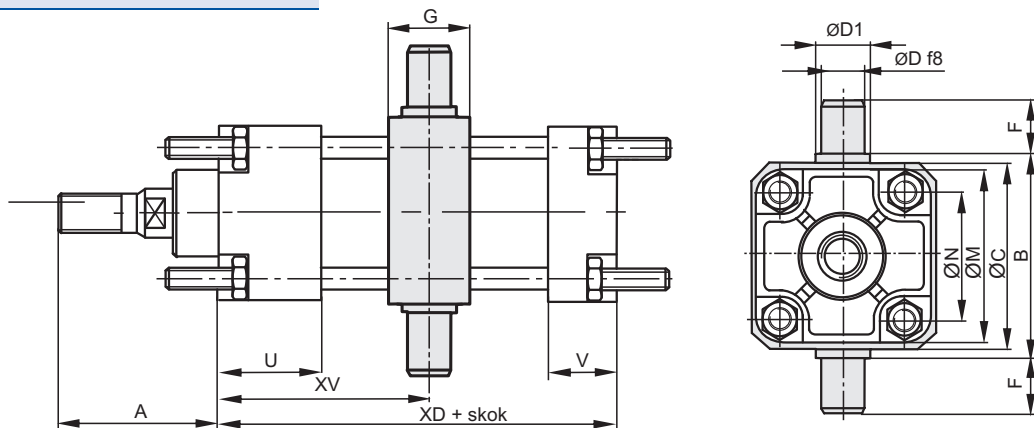

Średnica siłownika [mm]	Numer zamówieniowy													Wymiary [mm]	
	A	B	C	OD	OD1	F	G	M	N	U	V	D	XV min. max.*)		
32	45	50	46	12	20	12	22	45	33	22	17	30	34	52	10.004E.05.
40	70	63	58	16	25	16	30	52	40	40	23	110	60	70	10.004F.05
50	70	73	68	16	25	16	30	65	49	37	23	110	60	70	10.004G.05.
63	85	90	84	20	30	20	35	75	59	43	27	125	64.5	79.5	10.004H.05.
80	85	108	102	20	30	20	35	95	75	37	27	125	64.5	79.5	10.004J.05.
100	110	131	124	25	36	25	40	115	90	51	32	145	74	91	10.004K.05.
125	110	159	152	25	36	25	40	140	110	51	32	145	74	91	10.004L.05.
160	135	198	190	32	45	32	50	180	140	57	43	180	91	110	10.004M.05.
200	135	248	240	32	45	32	50	220	175	57	43	180	91	110	10.004N.05.

¹⁾ Wymiar XV_{max} dla skoku 0 mm, do wymiaru XV_{max} należy doliczyć skok siłownika

²⁾ Jarzmo sprzedaje się zamontowane na siłowniku w określonej odległości XV. W miejsce oznaczone xxxx należy wstawić konkretną żadaną wartość XV w mm np.: Jarzmo do siłownika D40x100 z wymiarem XV=125mm - 10.004F.05.0125

ŁAPA MS1

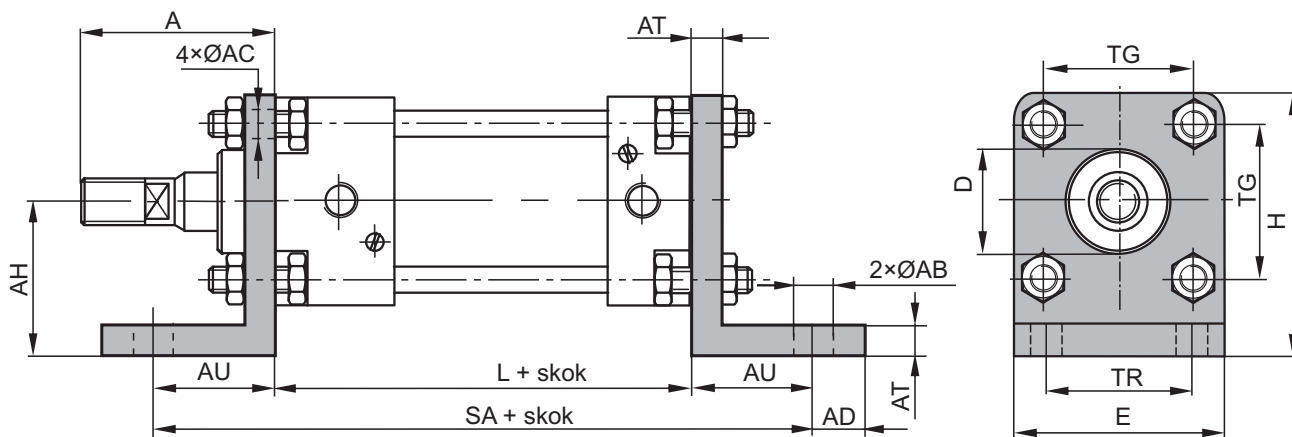

Średnica siłownika [mm]	Wymiary [mm]														Wykonanie materiałowe	Numer zamówieniowy
	A	OAB	OAC	AD	AH	AT	ODH11	AU	E	H	L	SA	TG	TR		
40	70	9	7	8	36	8	32	27	52	62	110	164	40	36	żeliwo	10.004F.03.
	70	9	7	8	36	8	32	27	52	62	110	164	40	36	odlew ciśnieniowy z Al	10.004F.03.A
50	70	11	9	10	45	10	32	35	65	77	110	180	49	45	żeliwo	10.004G.03.
	70	11	9	10	45	10	32	35	65	77	110	180	49	45	odlew ciśnieniowy z Al	10.004G.03.A
63	85	11	9	10	50	10	45	35	75	87	125	195	59	55	żeliwo	10.004H.03.
	85	11	9	10	50	10	45	35	75	87	125	195	59	55	odlew ciśnieniowy z Al	10.004H.03.A
80	85	14	11	12	63	12	45	43	95	110	125	211	75	70	żeliwo	10.004J.03.
	85	14	11	12	63	12	45	43	95	110	125	211	75	70	odlew ciśnieniowy z Al	10.004J.03.A
100	110	14	11	12	73	12	55	43	115	130	145	231	90	90	żeliwo	10.004K.03.
	110	14	11	12	73	12	55	43	115	130	145	231	90	90	odlew ciśnieniowy z Al	10.004K.03.A
125	110	18	14	16	91	15	55	52	140	161	145	249	110	100	żeliwo	10.004L.03.
160	135	22	18	18	115	20	65	62	180	205	180	304	140	130	żeliwo	10.004M03.
200	135	22	18	18	135	20	65	62	220	245	180	304	175	170	żeliwo	10.004N.03.

KOŁNIERZ

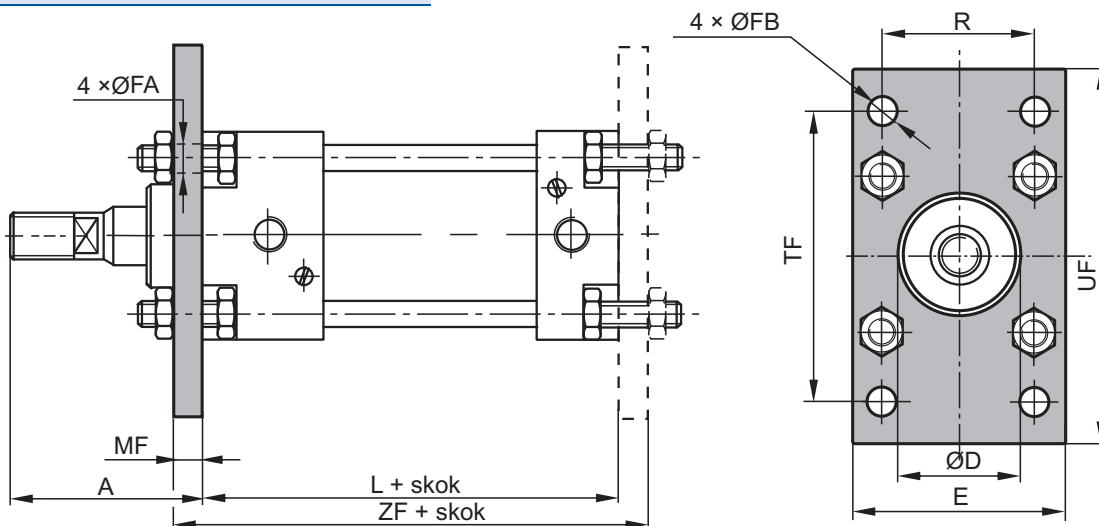

Średnica siłownika [mm]	Wymiary [mm]											Numer zamówieniowy
	A	OD	E	OFA	OFB	L	MF	R	TF	UF	ZF	
40	70	32	52	7	9	110	8	40	78	90	118	10.004F.04.
50	70	32	65	9	11	110	10	49	94	110	120	10.004G.04.
63	85	45	75	9	11	125	10	59	104	120	135	10.004H.04.
80	85	45	95	11	14	125	12	75	130	150	137	10.004J.04.
100	110	55	115	11	14	145	12	90	150	170	157	10.004K.04.
125	110	55	140	14	18	145	16	110	180	205	161	10.004L.04.
160	135	65	180	18	22	180	20	140	228	260	200	10.004M.04.
200	135	65	220	18	22	180	20	175	268	300	200	10.004N.04.