

# SS - STAINLESS STEEL

SUBMERSIBLE PUMPS AND MOTORS





THE INTERNATIONAL CERTIFICATION NETWORK

## CERTIFICATE

IQNet and its partner  
**CISQ/IMQ-CSQ**  
hereby certify that the organization  
**DWT HOLDING SPA**  
VIA MARCO POLO 14 - 35035 MESTRINO (PD)  
BRENDOLA (VI) - CASTELLO DI GODEGO (TV) - BIENTINA (PI) -  
SAN GERMANO DEI BERICI (VI) - GESSATE (MI) -  
PRC CHINA

for the following field of activities  
*Design, production, sale and assistance of components and electronic controls for pumps, electropumps, and pump sets for cold and hot water for civil, industrial and agricultural use*  
Refer to quality manual for details of applications to ISO 9001:2008 requirements

has implemented and maintains a  
**Quality Management System**  
which fulfills the requirements of the following standard

**ISO 9001:2008**

Issued on: 2013 - 09 - 23      Expiry date: 2015 - 06 - 15

Registration Number: IT - 824



*Michael Drechsel*  
Michael Drechsel  
President of IQNET



*Ing. Claudio Proveti*  
Ing. Claudio Proveti  
President of CISQ

IQNet Partners\*:

AFNOR Spain AFNOR Certification France AIH-Vinçotte International Belgium ANCI-SIGE Mexico APCR Portugal CCC Cyprus  
CISQ Italy CQC China CQM China COS Czech Republic Csc Cert Croatia DQS Holding GmbH Germany DS Denmark  
FCVJ Brazil FONDONORMA Venezuela ICONTEC Colombia IMNC Mexico INNORPI Tunisia  
Inspecta Certification Finland IRAM Argentina IQA Japan KFQ Korea MIRTEC Greece MSZT Hungary Nemko AS Norway  
NSAI Ireland PCBC Poland Quality Austria Austria RR Russia SII Israel SIQ Slovenia SIRIM QAS International Malaysia  
SQS Switzerland SRAC Romania TST St. Petersburg Russia TSI Turkey YUQS Serbia  
IQNet is represented in the USA by: AFNOR Certification, CISQ, DQS Holding GmbH and NSAI Inc.

\* The list of IQNet partners is valid at the time of issue of this certificate. Updated information is available under: [www.iqnet-certification.com](http://www.iqnet-certification.com)

All. 1 di 1  
Ann. 1 di 1



[www.imq.it](http://www.imq.it)

ALLEGATO CERTIFICATO n. **9101.COGE**  
ANNEX CERTIFICATE

(\*) Unità Operative:  
(\*) Operative Units:

**DAB PUMPS SPA**  
VIA BONANNIO PISANO 1 - 56031 BIENTINA (PI)

**TESLA SRL**  
VIA DEL LAVORO 3 - 36040 SAN GERMANO DEI BERICI (VI)

**TESLA SRL**  
VIA BERGAMO 2 - 20060 GESSATE (MI)

**DAB PUMPS QINGDAO CO. LTD.**  
40 KAITUO ROAD, QINGDAO DEVELOPMENT ZONE - SHANGDONG PROVINCE, PRC CHINA

DATE:	PRIMA CERTIFICAZIONE FIRST CERTIFICATION	EMISSIONE CORRENTE CURRENT ISSUE	SCADENZA EXPIRY
	1995-07-17	2013-09-23	2015-06-15

*Proveti*  
IMQ S.p.A. - VIA QUINTILIANO, 43 - 20138 MILANO



EA 18, 19

La validità del certificato è subordinata a verifiche annuali e a successive emissioni di Sistemi di Gestione con periodo di validità triennale.  
The validity of the certificate is subjected to annual audit and a re-assessment of the whole Management System within three years.



IQNet, the association of the world's first class certification bodies, is the largest provider of management system certification in the world. IQNet is comprised of more than 20 bodies and covers over 100 subdivisions all over the globe.

CISQ è la Federazione Italiana di Organismi di Certificazione del sistema di gestione aziendale.  
CISQ is the Italian Federation of management system Certification Bodies.



[www.imq.it](http://www.imq.it)

CERTIFICATO N.  
CERTIFICATE N. **9101.COGE**

SI CERTIFICA CHE IL SISTEMA QUALITÀ DI  
WE HEREBY CERTIFY THAT THE QUALITY SYSTEM OPERATED BY  
**DWT HOLDING SPA**  
VIA MARCO POLO 14 - 35035 MESTRINO (PD)

UNITÀ OPERATIVE  
OPERATIVE UNITS  
**DAB PUMPS**  
VIA MARCO POLO 14 - 35035 MESTRINO (PD)  
**DAB PUMPS**  
VIA EINAUDI 2 - 36040 BRENDOLA (VI)  
**DAB PUMPS**  
VIA E. FERMI 6-8-10 - 31030 CASTELLO DI GODEGO (TV)

Vedere gli Allegati per le altre Unità Operative (n° 1 pagina)  
View the Annexes for the other Operative Units (n° 1 page)

È CONFORME ALLA NORMA  
IS IN COMPLIANCE WITH THE STANDARD  
**ISO 9001:2008**

PER LE SEGUENTI ATTIVITÀ  
FOR THE FOLLOWING ACTIVITIES

Progettazione, produzione, vendita e assistenza di componenti e controlli elettronici per pompe, elettropompe e gruppi di pompaggio per acqua fredda e calda ad uso civile, industriale ed agricolo  
*Design, production, sale and assistance of components and electronic controls for pumps, electropumps, and pump sets for cold and hot water for civil, industrial and agricultural use*

Riferirsi al manuale della qualità per l'applicabilità dei requisiti della norma ISO 9001:2008  
Refer to quality manual for details of applications to ISO 9001:2008 requirements

IL PRESENTE CERTIFICATO È SOGGETTO AL RIPETTO DEL  
REGOLAMENTO PER LA CERTIFICAZIONE DEI SISTEMI DI GESTIONE  
THE USE AND THE VALIDITY OF THE CERTIFICATE SHALL SATISFY THE  
REQUIREMENTS OF THE RULES FOR CERTIFICATION OF MANAGEMENT SYSTEMS

DATE:	PRIMA CERTIFICAZIONE FIRST CERTIFICATION	EMISSIONE CORRENTE CURRENT ISSUE	SCADENZA EXPIRY
	1995-07-17	2013-09-23	2015-06-15

*Proveti*  
IMQ S.p.A. - VIA QUINTILIANO, 43 - 20138 MILANO



EA 18, 19

La validità del certificato è subordinata a verifiche annuali e a successive emissioni di Sistemi di Gestione con periodo di validità triennale.  
The validity of the certificate is subjected to annual audit and a re-assessment of the whole Management System within three years.



IQNet, the association of the world's first class certification bodies, is the largest provider of management system certification in the world. IQNet is comprised of more than 20 bodies and covers over 100 subdivisions all over the globe.

CISQ è la Federazione Italiana di Organismi di Certificazione del sistema di gestione aziendale.  
CISQ is the Italian Federation of management system Certification Bodies.



## SUBMERSIBLE PUMPS



**SS6**

PAG. 3



**SS8**

PAG. 54



**SS7**

PAG. 44



**SS10**

PAG. 69

## SUBMERSIBLE MOTORS



**6GF - 6GX**

PAG. 74



**TR10**

PAG. 83



**TR6**

PAG. 77



**TR12**

PAG. 86



**TR8**

PAG. 80

## HYDRAULIC EFFICIENCY

## CONTROL PANELS

## TECHNICAL APPENDIX

PAG. 89



PAG. 97

PAG. 101

### PERFORMANCE RANGE

The performance curves are based on the kinematic viscosity values = 1 mm<sup>2</sup>/s and density equal to 1000 Kg/m<sup>3</sup>. Curve tolerance according to ISO 9906.

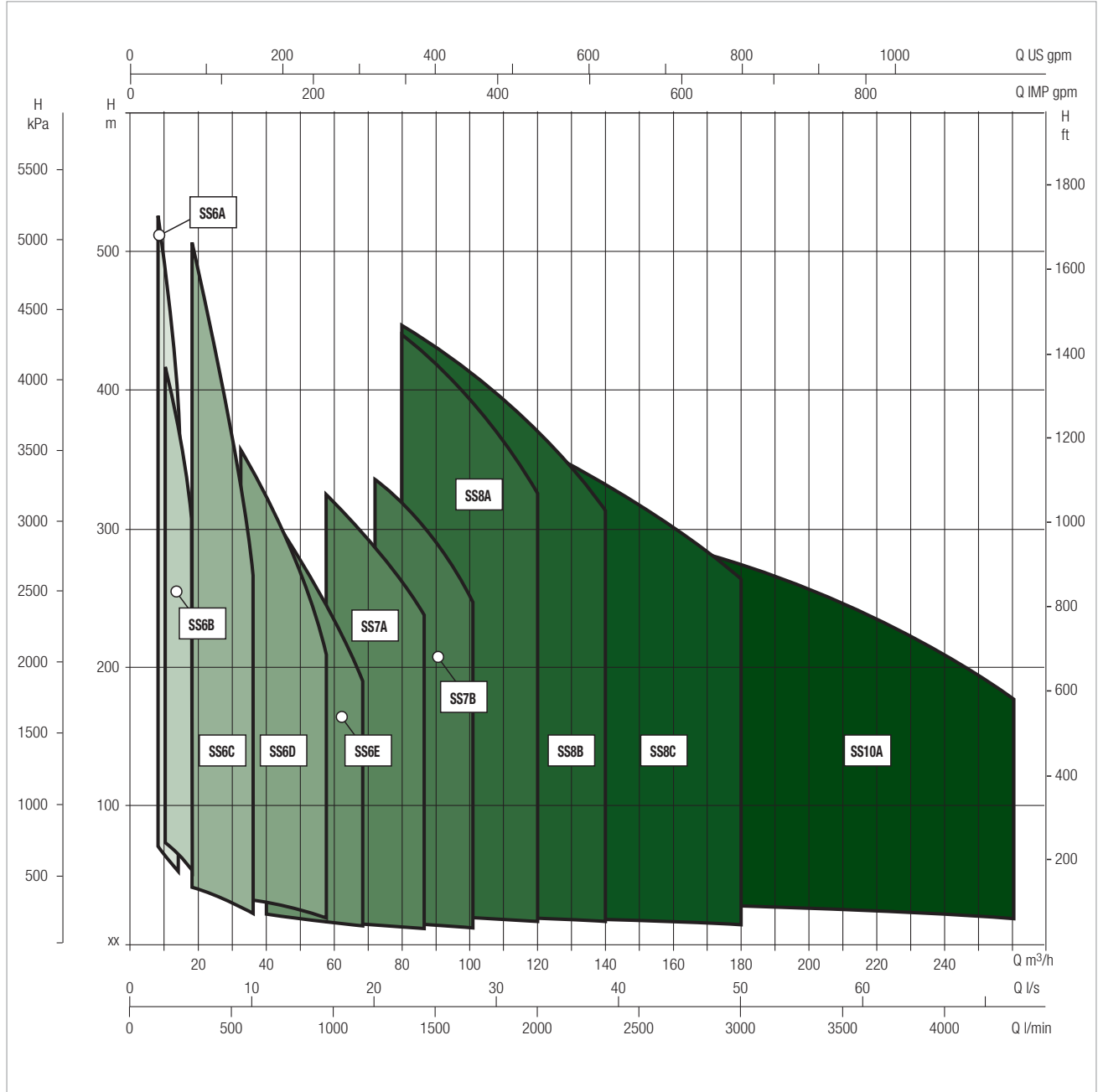



## TECHNICAL DATA

**Performance range:** flow up to 75 m<sup>3</sup>/h and max head of 670 m

**Max. quantity of sand/silt:** 50g/m<sup>3</sup>

**Max. ambient temperature:** 30°C (50°C available on request)

**Outlet connection diameter (inside threaded):** SS6 A – SS6 B : 2 ½"  
SS6 C : 3"  
SS6 D – SS6 E : 4"

**Nr of starts:** refer to the motor specification

**Motor Cooling flow:** refer to the motor specification

**Installation:** horizontal or vertical, refer to the motor specification

## APPLICATIONS

Multistage mixed-flow borehole electric pumps, completely made in stainless steel (AISI 304L or AISI 316 on request), usable for wells from a minimum diameter equal to pump size or greater and capable of developing a wide range of Flows and Heads.

These pumps can be used in a wide range of lifting, distributing, and pressuring application: domestic and general water supply; sprinkler and drip irrigations systems; fire-fighting installations; lowering of groundwater level; industrial supplies as mining, hot springs, autoclaves and tanks.

These pumps are suitable both for standard water and for aggressive water applications by choosing the proper manufacturing material (AISI 304L or AISI 316) both for hydraulic part and motor.

Special version of motors with PE2+PA windings can be used on request for high-temperature water applications up to maximum 50°C.

Pumps can be installed both vertically and horizontally simply by removing the non-return valve and adding a cooling sleeve to the suction case (the only remark is to check the motor applicability to horizontal operations, refer to the motor specifications section).

## CONSTRUCTION FEATURES OF PUMP

Mixed flow pumps with diffusers, impellers, brackets, suction case and discharge case completely made of stainless steel AISI 304 in order to provide maximum strength, durability, wear and tear resistance.

The impellers are balanced and locked to the shaft with a specially shaped collet and nut coupling, in order to guarantee ease-to-assembly feature and avoid vibration sensitive malfunctions and noise increase during rotation.

Rubber bearings that drive the shaft are water lubricated and have sand channels to make enable the sand particles leave the pump with the pumped liquid (maximum permissible sand content 50 gr/m<sup>3</sup>).

Built-in non returned valve provided in order to minimize local friction losses.

Stainless steel strainer provided in order to prevent particles over a certain size from entering the pump.

Coupling with 6", 8" or 10" motor depending on the power requested by hydraulic part:

- 6GF: 6" canned submersible motor
- TR6: 6" rewindable submersible motor
- TR8: 8" rewindable submersible motor
- TR10: 10" rewindable submersible motor

For inverter application refer to the detailed motor specification.

## ON REQUEST:

- Pump body stainless steel AISI 316 for aggressive water application
- Impellers stainless steel AISI 316
- Motors in full stainless steel AISI 316 for aggressive water application
- Star/Delta starting version
- Special version of the motor for high temperature application
- Non-standard power coupling

### MATERIALS

N°	PART NAME	MATERIAL
1	Suction Case	Stainless Steel (AISI 304L)
2	Filter	Stainless Steel (AISI 304L)
3	Suction Case Wear Ring	Bronze (ASTM B145-4A)
4	Pump Shaft	Stainless Steel (AISI 420)
5	Collet	Stainless Steel
6	Impeller Wear Ring	STAINLESS STEEL (AISI 304)
7	Impeller	Stainless Steel (AISI 304L)
8	Diffuser	Stainless Steel (AISI 304L)
9	Rubber Bearing	Rubber
10	Diffuser Wear Ring	Rubber
11	Nut for Stop Ring	Stainless Steel (AISI 304L)
12	Bearing	Rubber
13	Shaft Stopper	Bronze (ASTM B145-4A)
14	Valve	Stainless Steel (AISI 304)
15	Discharge Case	Stainless Steel (AISI 304)
16	TIE ROD	STAINLESS STEEL (AISI 304L)
17	CABLE GUARD	STAINLESS STEEL (AISI 304)
18	TIR ROD NUT	STAINLESS STEEL (AISI 303)
19	NAME PLATE	STAINLESS STEEL (AISI 304)

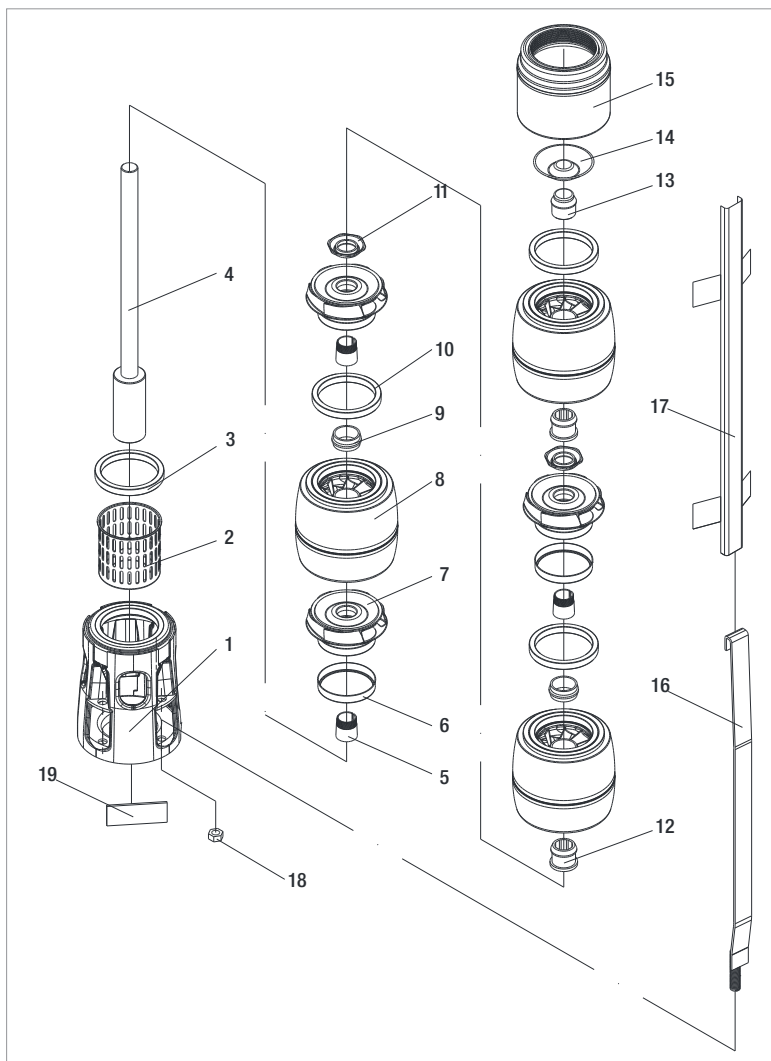

**- Designation Index:**  
(EXAMPLE)

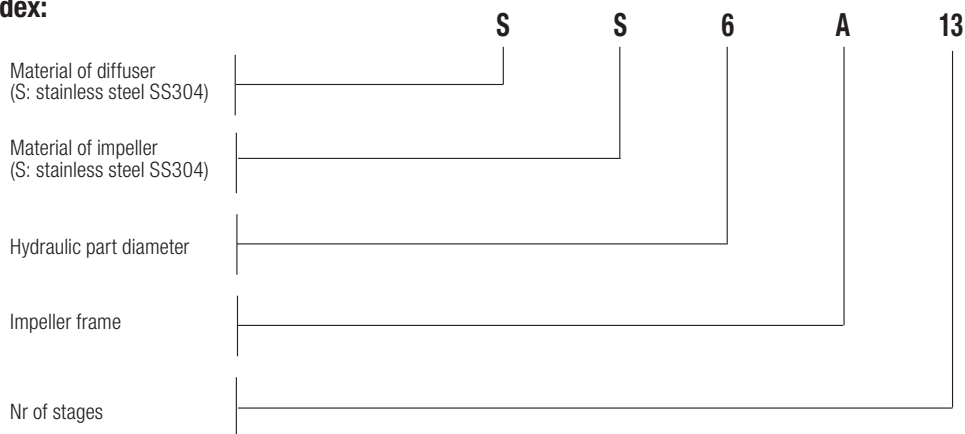

### PERFORMANCE 50 Hz - 2 POLES

MODEL	ELECTRICAL DATA		HYDRAULIC DATA											STANDARD MOTOR COUPLING
	P2 NOMINAL		Q=m <sup>3</sup> h	0	2	4	6	8	10	12	14	16	17	
	kW	HP	Q=l/min	0	33,3	66,6	100	133,3	166,6	200	233,3	266,6	283,3	
SS6A 08	4	5,5	H (mt)	75	75	74	73	70	65	59	51	41	36	6"
SS6A 09	4	5,5		84	84	84	82	78	73	66	57	46	40	6"
SS6A 10	4	5,5		93	94	93	91	87	81	73	63	51	44	6"
SS6A 11	4	5,5		103	103	102	100	96	89	81	70	56	49	6"
SS6A 12	5,5	7,5		112	112	112	109	104	97	88	76	61	53	6"
SS6A 13	5,5	7,5		121	122	121	118	113	105	95	82	67	58	6"
SS6A 14	5,5	7,5		131	131	130	127	122	114	103	89	72	62	6"
SS6A 15	5,5	7,5		140	140	139	136	130	122	110	95	77	67	6"
SS6A 16	7,5	10		149	150	149	145	139	130	117	101	82	71	6"
SS6A 17	7,5	10		159	159	158	154	148	138	124	108	87	76	6"
SS6A 18	7,5	10		168	169	167	163	156	146	132	114	92	80	6"
SS6A 19	7,5	10		177	178	177	172	165	154	139	120	97	84	6"
SS6A 20	7,5	10		187	187	186	182	174	162	146	127	102	89	6"
SS6A 21	7,5	10		196	197	195	191	182	170	154	133	108	93	6"
SS6A 22	9,2	12,5		205	206	204	200	191	178	161	139	113	98	6"
SS6A 23	9,2	12,5		215	215	214	209	200	186	168	146	118	102	6"
SS6A 24	9,2	12,5		224	225	223	218	209	195	176	152	123	107	6"

### ELECTRICAL DATA AND DIMENSIONS

MODEL	MOTOR *	ELECTRICAL DATA			OPERATING BY INVERTER	HORIZONTAL INSTALLATION	L2 mm	L mm	L1 mm	D mm	D1 mm	TOTAL WEIGHT Kg
		P2 NOMINAL		In A								
		kW	HP									
SS6A 08	6GF	4	5,5	10,6	●	●	1353	600	753	141	132	54,4
SS6A 09	6GF	4	5,5	10,6	●	●	1414	600	814	141	132	56,4
SS6A 10	6GF	4	5,5	10,6	●	●	1474	600	874	141	132	57,4
SS6A 11	6GF	4	5,5	10,6	●	●	1535	600	935	141	132	59,4
SS6A 12	6GF	5,5	7,5	14	●	●	1626	631	995	141	132	63,6
	TR6	5,5	7,5	13	○	●	1802	807	995	144	132	71
SS6A 13	6GF	5,5	7,5	14	●	●	1687	631	1056	141	132	65,6
	TR6	5,5	7,5	13	○	●	1863	807	1056	144	132	73
SS6A 14	6GF	5,5	7,5	14	●	●	1747	631	1116	141	132	66,6
	TR6	5,5	7,5	13	○	●	1923	807	1116	144	132	74
SS6A 15	6GF	5,5	7,5	14	●	●	1808	631	1177	141	132	68,6
	TR6	5,5	7,5	13	○	●	1984	807	1177	144	132	76
SS6A 16	6GF	7,5	10	18	●	●	1897	660	1237	141	132	72,2
	TR6	7,5	10	18	○	●	2074	837	1237	144	132	80
SS6A 17	6GF	7,5	10	18	●	●	1958	660	1298	141	132	73,2
	TR6	7,5	10	18	○	●	2135	837	1298	144	132	81
SS6A 18	6GF	7,5	10	18	●	●	2018	660	1358	141	132	75,2
	TR6	7,5	10	18	○	●	2195	837	1358	144	132	83
SS6A 19	6GF	7,5	10	18	●	●	2079	660	1419	141	132	76,2
	TR6	7,5	10	18	○	●	2256	837	1419	144	132	84
SS6A 20	6GF	7,5	10	18	●	●	2139	660	1479	141	132	78,2
	TR6	7,5	10	18	○	●	2316	837	1479	144	132	86
SS6A 21	6GF	7,5	10	18	●	●	2200	660	1540	141	132	79,2
	TR6	7,5	10	18	○	●	2377	837	1540	144	132	87
SS6A 22	6GF	9,2	12,5	22	●	●	2285	685	1600	141	132	84,6
	TR6	9,2	12,5	21	○	●	2467	867	1600	144	132	91
SS6A 23	6GF	9,2	12,5	22	●	●	2346	685	1661	141	132	85,6
	TR6	9,2	12,5	21	○	●	2528	867	1661	144	132	92
SS6A 24	6GF	9,2	12,5	22	●	●	2406	685	1721	141	132	87,6
	TR6	9,2	12,5	21	○	●	2588	867	1721	144	132	94

\* Motor 6GF: 6" canned submersible motors.  
 Motor TR6: 6" rewindable submersible motors.

●	Allowed
○	Only PE2 + PA version



# SS6A

## SUBMERSIBLE PUMPS 6"

The performance curves are based on the kinematic viscosity values = 1 mm<sup>2</sup>/s and density equal to 1000 Kg/m<sup>3</sup>. Curve tolerance according to ISO 9906.

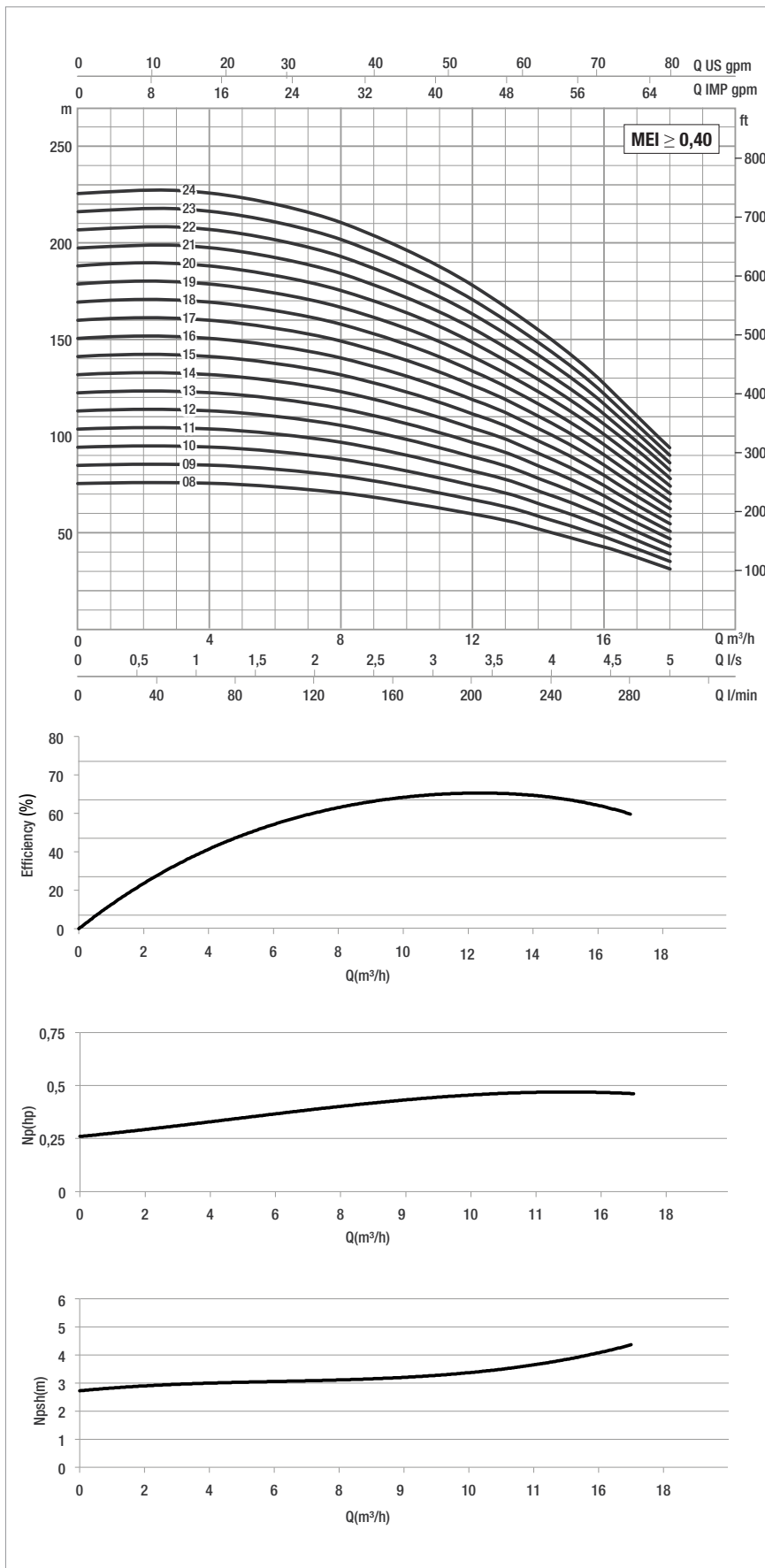
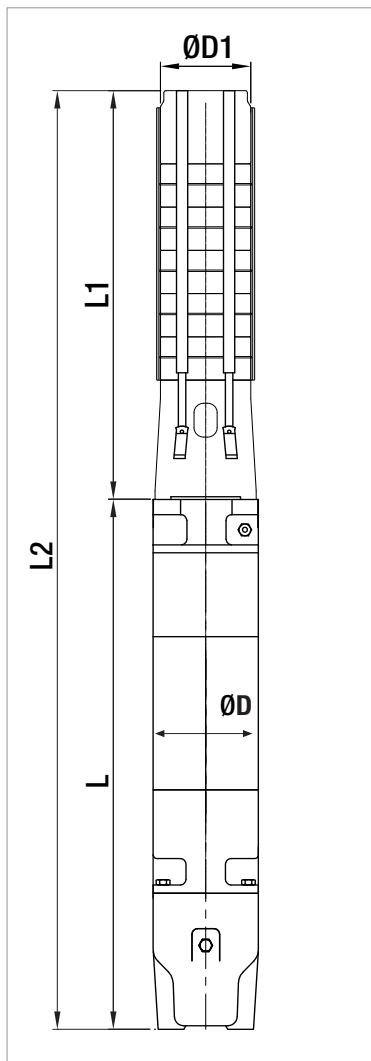

For hydraulic efficiency see pag. 89

### PERFORMANCE 50 Hz - 2 POLES

MODEL	ELECTRICAL DATA		HYDRAULIC DATA											STANDARD MOTOR COUPLING
	P2 NOMINAL		Q=m³h	0	2	4	6	8	10	12	14	16	17	
	kW	HP	Q=l/min	0	33,3	66,6	100	133,3	166,6	200	233,3	266,6	283,3	
SS6A 25	9,2	12,5	H (m)	233	234	232	227	217	203	183	158	128	111	6"
SS6A 26	9,2	12,5		243	244	242	236	226	211	190	165	133	116	6"
SS6A 27	11	15		252	253	251	245	235	219	198	171	138	120	6"
SS6A 28	11	15		261	262	260	254	243	227	205	177	143	124	6"
SS6A 29	11	15		270	272	270	263	252	235	212	184	149	129	6"
SS6A 30	11	15		280	281	279	272	261	243	220	190	154	133	6"
SS6A 31	13	17,5		289	290	288	281	269	251	227	196	159	138	6"
SS6A 32	13	17,5		298	300	297	290	278	259	234	202	164	142	6"
SS6A 33	13	17,5		308	309	307	300	287	268	242	209	169	147	6"
SS6A 34	13	17,5		317	318	316	309	295	276	249	215	174	151	6"
SS6A 35	13	17,5		326	328	325	318	304	284	256	221	179	156	6"
SS6A36	13	17,5		336	337	335	327	313	292	264	228	184	160	6"
SS6A 37	13	17,5		345	347	344	336	321	300	271	234	190	164	6"
SS6A 38	15	20		354	356	353	345	330	308	278	240	195	169	6"
SS6A 39	15	20		364	365	362	354	339	316	286	247	200	173	6"
SS6A 40	15	20		373	375	372	363	348	324	293	253	205	178	6"
SS6A 41	15	20		382	384	381	372	356	332	300	259	210	182	6"
SS6A 42	18,5	25		392	393	390	381	365	341	308	266	215	187	6"

### ELECTRICAL DATA AND DIMENSIONS

MODEL	MOTOR *	ELECTRICAL DATA				HORIZONTAL INSTALLATION	L2 mm	L mm	L1 mm	D mm	D1 mm	TOTAL WEIGHT Kg
		P2 NOMINAL		In A	OPERATING BY INVERTER							
		kW	HP									
SS6A 25	6GF	9,2	12,5	22	●	●	2467	685	1782	141	132	88,6
	TR6	9,2	12,5	21	○	●	2649	867	1782	144	132	95
SS6A 26	6GF	9,2	12,5	22	●	●	2527	685	1842	141	132	89,6
	TR6	9,2	12,5	21	○	●	2709	867	1842	144	132	96
SS6A 27	6GF	11	15	25,5	●	●	2633	730	1903	141	132	96
	TR6	11	15	25	○	●	2800	897	1903	144	132	103
SS6A 28	6GF	11	15	25,5	●	●	2693	730	1963	141	132	97
	TR6	11	15	25	○	●	2860	897	1963	144	132	104
SS6A 29	6GF	11	15	25,5	●	●	2754	730	2024	141	132	99
	TR6	11	15	25	○	●	2921	897	2024	144	132	106
SS6A 30	6GF	11	15	25,5	●	●	2814	730	2084	141	132	100
	TR6	11	15	25	○	●	2981	897	2084	144	132	107
SS6A 31	6GF	15	20	33,4	●	●	2930	785	2145	141	132	108
	TR6	13	17,5	29	○	●	3072	927	2145	144	132	114
SS6A 32	6GF	15	20	33,4	●	●	2990	785	2205	141	132	109
	TR6	13	17,5	29	○	●	3132	927	2205	144	132	115
SS6A 33	6GF	15	20	33,4	●	●	3051	785	2266	141	132	111
	TR6	13	17,5	29	○	●	3193	927	2266	144	132	117
SS6A 34	6GF	15	20	33,4	●	●	3111	785	2326	141	132	112
	TR6	13	17,5	29	○	●	3253	927	2326	144	132	118
SS6A 35	6GF	15	20	33,4	●	●	3172	785	2387	141	132	113
	TR6	13	17,5	29	○	●	3314	927	2387	144	132	119
SS6A 36	6GF	15	20	33,4	●	●	3232	785	2447	141	132	115
	TR6	13	17,5	29	○	●	3374	927	2447	144	132	121
SS6A 37	6GF	15	20	33,4	●	●	3293	785	2508	141	132	116
	TR6	13	17,5	29	○	●	3435	927	2508	144	132	122
SS6A 38	6GF	15	20	33,4	●	●	3353	785	2568	141	132	118
	TR6	15	20	32	○	●	3565	997	2568	144	132	136
SS6A 39	6GF	15	20	33,4	●	●	3664	785	2879	141	167	150
	TR6	15	20	32	○	●	3876	997	2879	144	167	168
SS6A 40	6GF	15	20	33,4	●	●	3724	785	2939	141	167	151
	TR6	15	20	32	○	●	3936	997	2939	144	167	169
SS6A 41	6GF	15	20	33,4	●	●	3785	785	3000	141	167	153
	TR6	15	20	32	○	●	3997	997	3000	144	167	171
SS6A 42	6GF	18,5	25	41	●	●	3920	860	3060	141	167	163
	TR6	18,5	25	39	○	●	4117	1057	3060	144	167	179

\* Motor 6GF: 6" canned submersible motors.  
 Motor TR6: 6" rewindable submersible motors.

●	Allowed
○	Only PE2 + PA version

# SS6A

## SUBMERSIBLE PUMPS 6"

The performance curves are based on the kinematic viscosity values = 1 mm<sup>2</sup>/s and density equal to 1000 Kg/m<sup>3</sup>. Curve tolerance according to ISO 9906.

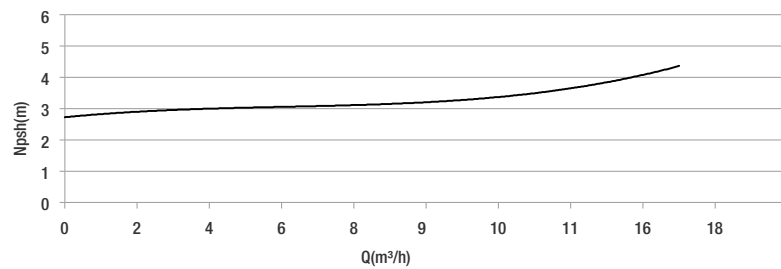
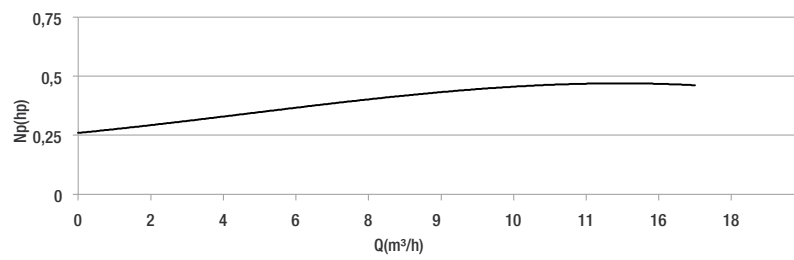
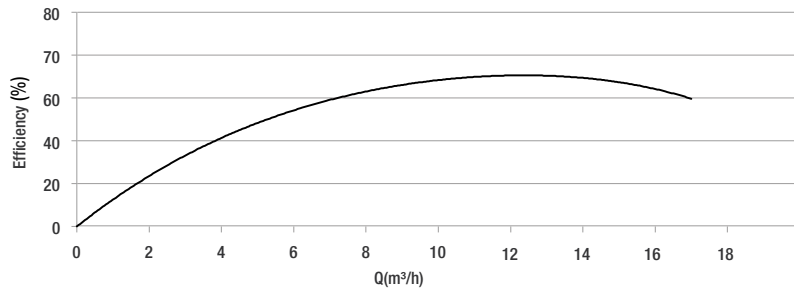
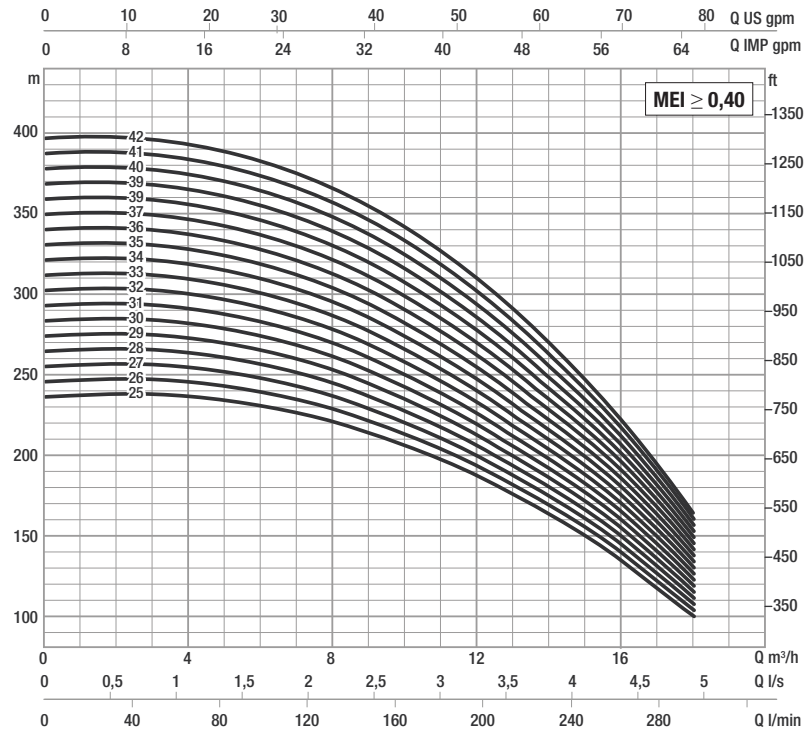
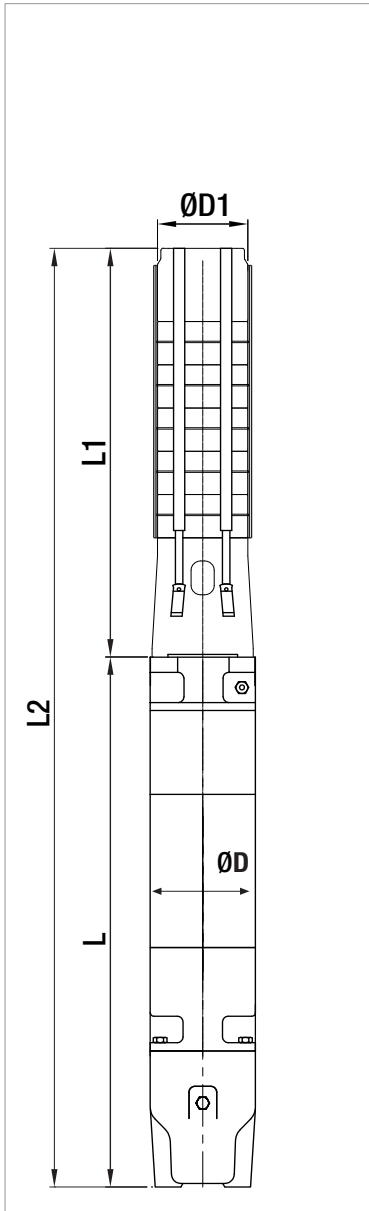

For hydraulic efficiency see pag. 89

### PERFORMANCE 50 Hz - 2 POLES

MODEL	ELECTRICAL DATA		HYDRAULIC DATA											STANDARD MOTOR COUPLING
	P2 NOMINAL		Q=m³h	0	2	4	6	8	10	12	14	16	17	
	kW	HP	Q=l/min	0	33,3	66,6	100	133,3	166,6	200	233,3	266,6	283,3	
SS6A 43	18,5	25	H (m)	401	403	400	390	374	349	315	272	220	191	6"
SS6A 44	18,5	25		410	412	409	399	382	357	322	278	225	196	6"
SS6A 45	18,5	25		420	421	418	408	391	365	330	285	231	200	6"
SS6A 46	18,5	25		429	431	428	418	400	373	337	291	236	204	6"
SS6A 47	18,5	25		438	440	437	427	408	381	344	297	241	209	6"
SS6A 48	18,5	25		448	450	446	436	417	389	352	304	246	213	6"
SS6A 49	18,5	25		457	459	455	445	426	397	359	310	251	218	6"
SS6A 50	22	30		466	468	465	454	434	405	366	316	256	222	6"
SS6A 51	22	30		476	478	474	463	443	414	373	323	261	227	6"
SS6A 52	22	30		485	487	483	472	452	422	381	329	266	231	6"
SS6A 53	22	30		494	496	493	481	460	430	388	335	272	236	6"
SS6A 54	22	30		504	506	502	490	469	438	395	342	277	240	6"
SS6A 55	22	30		513	515	511	499	478	446	403	348	282	244	6"
SS6A 56	22	30		522	524	520	508	487	454	410	354	287	249	6"
SS6A 57	22	30		532	534	530	517	495	462	417	361	292	253	6"
SS6A 58	22	30		541	543	539	526	504	470	425	367	297	258	6"
SS6A 59	22	30		550	553	548	536	513	478	432	373	302	262	6"
SS6A 60	22	30		560	562	558	545	521	486	439	380	307	267	6"

### ELECTRICAL DATA AND DIMENSIONS

MODEL	MOTOR *	ELECTRICAL DATA				HORIZONTAL INSTALLATION	L2 mm	L mm	L1 mm	D mm	D1 mm	TOTAL WEIGHT Kg
		P2 NOMINAL		In A	OPERATING BY INVERTER							
		kW	HP									
SS6A 43	6GF	18,5	25	41	●	●	3981	860	3121	141	167	165
	TR6	18,5	25	39	○	●	4178	1057	3121	144	167	181
SS6A 44	6GF	18,5	25	41	●	●	4041	860	3181	141	167	167
	TR6	18,5	25	39	○	●	4238	1057	3181	144	167	183
SS6A 45	6GF	18,5	25	41	●	●	4102	860	3242	141	167	168
	TR6	18,5	25	39	○	●	4299	1057	3242	144	167	184
SS6A 46	6GF	18,5	25	41	●	●	4162	860	3302	141	167	170
	TR6	18,5	25	39	○	●	4359	1057	3302	144	167	186
SS6A 47	6GF	18,5	25	41	●	●	4223	860	3363	141	167	172
	TR6	18,5	25	39	○	●	4420	1057	3363	144	167	188
SS6A 48	6GF	18,5	25	41	●	●	4283	860	3423	141	167	174
	TR6	18,5	25	39	○	●	4480	1057	3423	144	167	190
SS6A 49	6GF	18,5	25	41	●	●	4344	860	3484	141	167	175
	TR6	18,5	25	39	○	●	4541	1057	3484	144	167	191
SS6A 50	6GF	22	30	47	●	●	4464	920	3544	141	167	180,6
	TR6	22	30	49	○	●	4631	1087	3544	144	167	205
SS6A 51	6GF	22	30	47	●	●	4525	920	3605	141	167	182,6
	TR6	22	30	49	○	●	4692	1087	3605	144	167	207
SS6A 52	6GF	22	30	47	●	●	4585	920	3665	141	167	184,6
	TR6	22	30	49	○	●	4752	1087	3665	144	167	209
SS6A 53	6GF	22	30	47	●	●	4646	920	3726	141	167	186,6
	TR6	22	30	49	○	●	4813	1087	3726	144	167	211
SS6A 54	6GF	22	30	47	●	●	4706	920	3786	141	167	187,6
	TR6	22	30	49	○	●	4873	1087	3786	144	167	212
SS6A 55	6GF	22	30	47	●	●	4767	920	3847	141	167	189,6
	TR6	22	30	49	○	●	4934	1087	3847	144	167	214
SS6A 56	6GF	22	30	47	●	●	4827	920	3907	141	167	191,6
	TR6	22	30	49	○	●	4994	1087	3907	144	167	216
SS6A 57	6GF	22	30	47	●	●	4888	920	3968	141	167	193,6
	TR6	22	30	49	○	●	5055	1087	3968	144	167	218
SS6A 58	6GF	22	30	47	●	●	4948	920	4028	141	167	195,6
	TR6	22	30	49	○	●	5115	1087	4028	144	167	220
SS6A 59	6GF	22	30	47	●	●	5009	920	4089	141	167	196,6
	TR6	22	30	49	○	●	5176	1087	4089	144	167	221
SS6A 60	6GF	22	30	47	●	●	5069	920	4149	141	167	198,6
	TR6	22	30	49	○	●	5236	1087	4149	144	167	223

\* Motor 6GF: 6" canned submersible motors.  
 Motor TR6: 6" rewindable submersible motors.

●	Allowed
○	Only PE2 + PA version

# SS6A

## SUBMERSIBLE PUMPS 6"

The performance curves are based on the kinematic viscosity values = 1 mm<sup>2</sup>/s and density equal to 1000 Kg/m<sup>3</sup>. Curve tolerance according to ISO 9906.

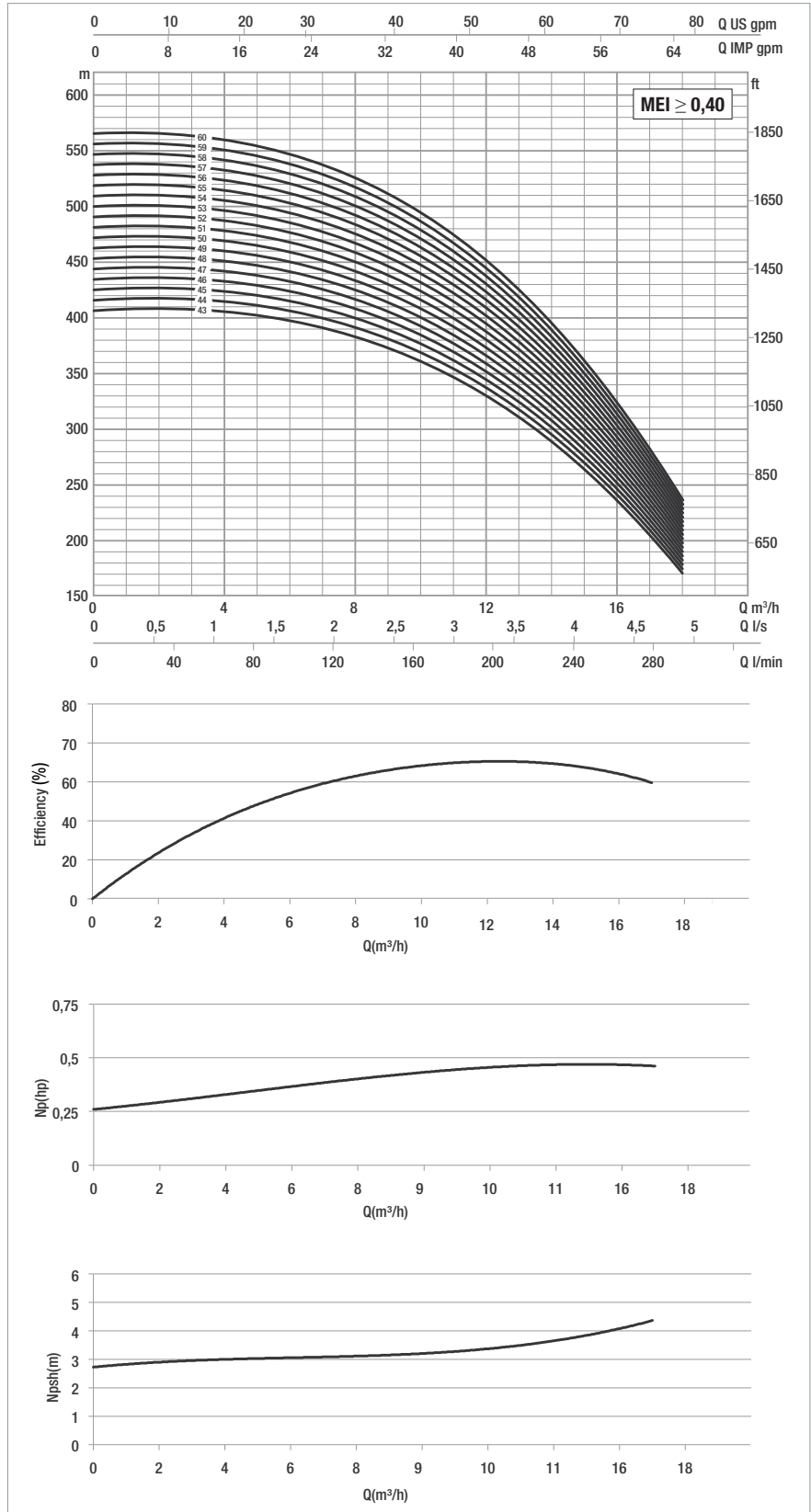
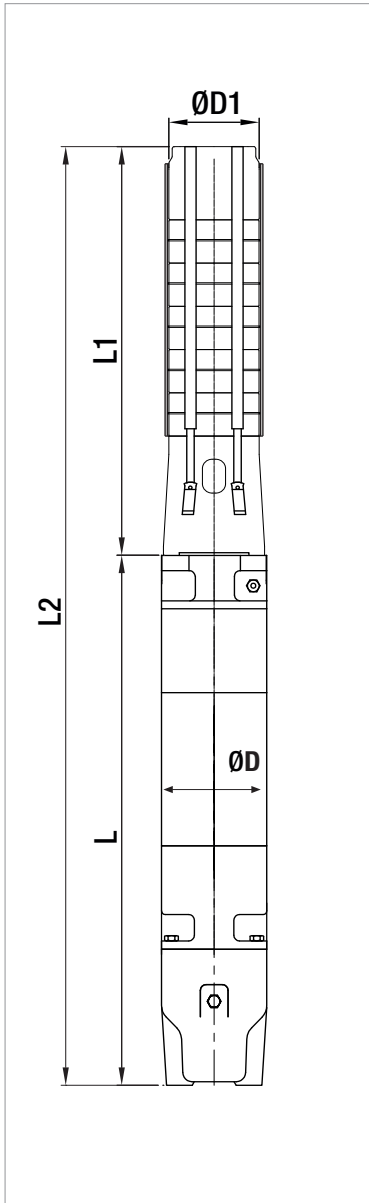

For hydraulic efficiency see pag. 89

### PERFORMANCE 50 Hz - 2 POLES

MODEL	ELECTRICAL DATA		Q=m <sup>3</sup> h Q=l/min	HYDRAULIC DATA										STANDARD MOTOR COUPLING
	P2 NOMINAL			0	6	8	10	12	14	15	16	18	20	
	kW	HP		0	100	133,3	166,6	200	233,3	250	266,6	300	333,3	
SS6B 07	4	5,5	H (m)	79	77	76	73	70	65	63	60	53	45	6"
SS6B 08	5,5	7,5		90	89	87	84	80	75	71	68	60	52	6"
SS6B 09	5,5	7,5		102	100	98	94	90	84	80	77	68	58	6"
SS6B 10	5,5	7,5		113	111	108	105	100	93	89	85	76	65	6"
SS6B 11	7,5	10		124	122	119	115	110	102	98	94	83	71	6"
SS6B 12	7,5	10		135	133	130	126	120	112	107	102	91	78	6"
SS6B 13	7,5	10		147	144	141	136	130	121	116	111	98	84	6"
SS6B 14	7,5	10		158	155	152	147	140	130	125	119	106	91	6"
SS6B 15	9,3	12,5		169	166	163	157	150	140	134	128	113	97	6"
SS6B 16	9,3	12,5		181	177	173	168	160	149	143	136	121	103	6"
SS6B 17	9,3	12,5		192	188	184	178	170	158	152	145	128	110	6"
SS6B 18	11	15		203	199	195	189	180	168	161	153	136	116	6"
SS6B 19	11	15		214	210	206	199	190	177	170	162	143	123	6"
SS6B 20	11	15		226	221	217	210	199	186	179	170	151	129	6"
SS6B 21	13	17,5		237	232	228	220	209	196	188	179	159	136	6"
SS6B 22	13	17,5		248	243	238	230	219	205	196	187	166	142	6"
SS6B 23	13	17,5		260	254	249	241	229	214	205	196	174	149	6"
SS6B 24	13	17,5		271	266	260	251	239	224	214	204	181	155	6"
SS6B 25	15	20		282	277	271	262	249	233	223	213	189	162	6"
SS6B 26	15	20		293	288	282	272	259	242	232	221	196	168	6"
SS6B 27	15	20		305	299	293	283	269	252	241	230	204	175	6"



### ELECTRICAL DATA AND DIMENSIONS

MODEL	MOTOR *	ELECTRICAL DATA				HORIZONTAL INSTALLATION	L2 mm	L mm	L1 mm	D mm	D1 mm	TOTAL WEIGHT Kg
		P2 NOMINAL		In A	OPERATING BY INVERTER							
		kW	HP									
SS6B 07	6GF	4	5,5	10,6	●	●	1293	600	693	141	132	53,4
SS6B 08	6GF	5,5	7,5	14	●	●	1384	631	753	141	132	58,6
	TR6	5,5	7,5	13	○	●	1560	807	753	144	132	66
SS6B 09	6GF	5,5	7,5	14	●	●	1445	631	814	141	132	59,6
	TR6	5,5	7,5	13	○	●	1621	807	814	144	132	67
SS6B 10	6GF	5,5	7,5	14	●	●	1505	631	874	141	132	60,6
	TR6	5,5	7,5	13	○	●	1681	807	874	144	132	68
SS6B 11	6GF	7,5	10	18	●	●	1595	660	935	141	132	65,2
	TR6	7,5	10	18	○	●	1772	837	935	144	132	73
SS6B 12	6GF	7,5	10	18	●	●	1655	660	995	141	132	66,2
	TR6	7,5	10	18	○	●	1832	837	995	144	132	74
SS6B 13	6GF	7,5	10	18	●	●	1716	660	1056	141	132	68,2
	TR6	7,5	10	18	○	●	1893	837	1056	144	132	76
SS6B 14	6GF	7,5	10	18	●	●	1776	660	1116	141	132	69,2
	TR6	7,5	10	18	○	●	1953	837	1116	144	132	77
SS6B 15	6GF	9,3	12,5	22	●	●	1862	685	1177	141	132	74,6
	TR6	9,2	12,5	21	○	●	2044	867	1177	144	132	81
SS6B 16	6GF	9,3	12,5	22	●	●	1922	685	1237	141	132	75,6
	TR6	9,2	12,5	21	○	●	2104	867	1237	144	132	82
SS6B 17	6GF	9,3	12,5	22	●	●	1983	685	1298	141	132	77,6
	TR6	9,2	12,5	21	○	●	2165	867	1298	144	132	84
SS6B 18	6GF	11	15	25,5	●	●	2088	730	1358	141	132	83
	TR6	11	15	25	○	●	2255	897	1358	144	132	90
SS6B 19	6GF	11	15	25,5	●	●	2149	730	1419	141	132	84
	TR6	11	15	25	○	●	2316	897	1419	144	132	91
SS6B 20	6GF	11	15	25,5	●	●	2209	730	1479	141	132	86
	TR6	11	15	25	○	●	2376	897	1479	144	132	93
SS6B 21	6GF	15	20	33,4	●	●	2325	785	1540	141	132	93
	TR6	13	17,5	29	○	●	2467	927	1540	144	132	99
SS6B 22	6GF	15	20	33,4	●	●	2385	785	1600	141	132	95
	TR6	13	17,5	29	○	●	2527	927	1600	144	132	101
SS6B 23	6GF	15	20	33,4	●	●	2446	785	1661	141	132	96
	TR6	13	17,5	29	○	●	2588	927	1661	144	132	102
SS6B 24	6GF	15	20	33,4	●	●	2506	785	1721	141	132	98
	TR6	13	17,5	29	○	●	2648	927	1721	144	132	104
SS6B 25	6GF	15	20	33,4	●	●	2567	785	1782	141	132	99
	TR6	15	20	32	○	●	2779	997	1782	144	132	117
SS6B 26	6GF	15	20	33,4	●	●	2627	785	1842	141	132	101
	TR6	15	20	32	○	●	2839	997	1842	144	132	119
SS6B 27	6GF	15	20	33,4	●	●	2688	785	1903	141	132	102
	TR6	15	20	32	○	●	2900	997	1903	144	132	120

\* **Motor 6GF:** 6" canned submersible motors.  
**Motor TR:** 6" rewindable submersible motors.

●	Allowed
○	Only PE2 + PA version

# SS6B

## SUBMERSIBLE PUMPS 6"

The performance curves are based on the kinematic viscosity values = 1 mm<sup>2</sup>/s and density equal to 1000 Kg/m<sup>3</sup>. Curve tolerance according to ISO 9906.

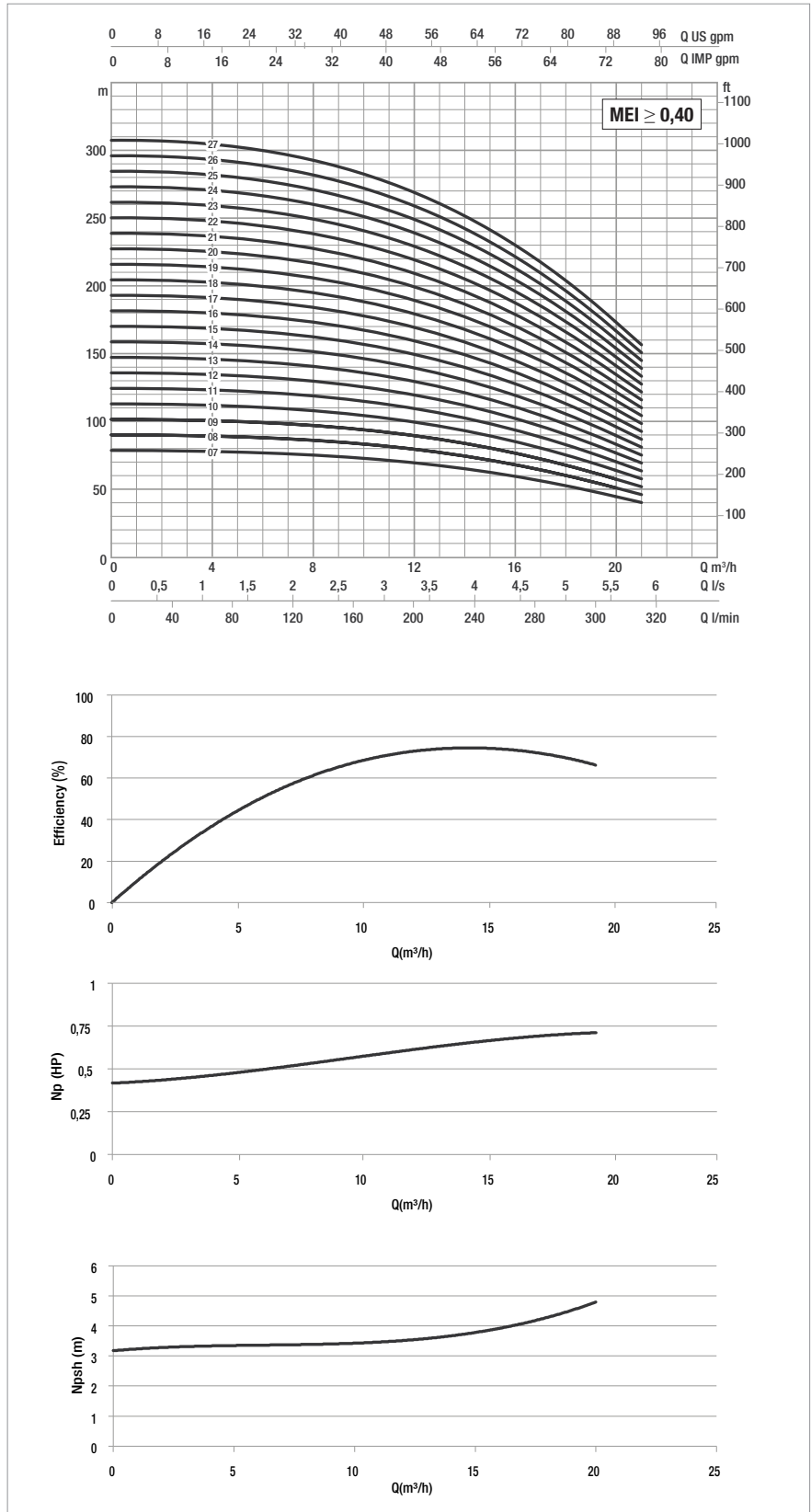
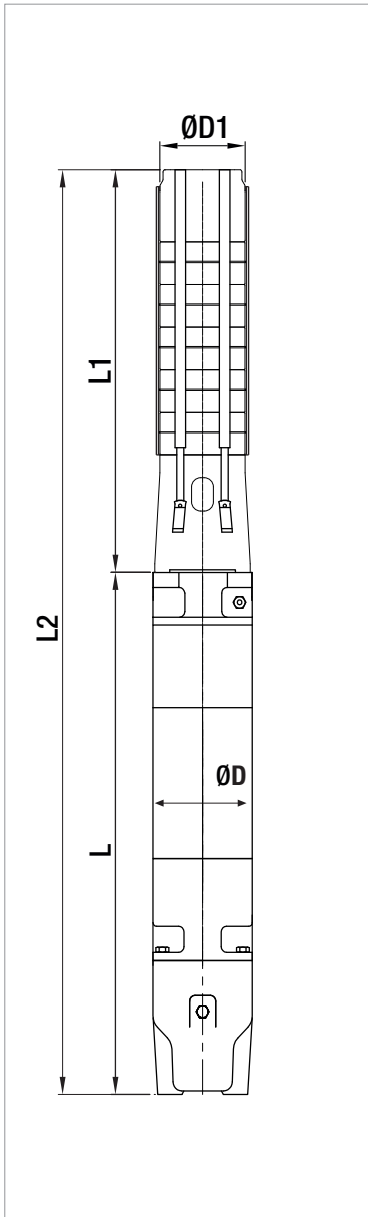

For hydraulic efficiency see pag. 89

### PERFORMANCE 50 Hz - 2 POLES

MODEL	ELECTRICAL DATA		HYDRAULIC DATA											STANDARD MOTOR COUPLING
	P2 NOMINAL		Q=m <sup>3</sup> h	0	6	8	10	12	14	15	16	18	20	
	kW	HP	Q=l/min	0	100	133,3	166,6	200	233,3	250	266,6	300	333,3	
SS6B 28	15	20	H (m)	316	310	303	293	279	261	250	238	211	181	6"
SS6B 29	18,5	25		327	321	314	304	289	270	259	247	219	188	6"
SS6B 30	18,5	25		339	332	325	314	299	280	268	255	227	194	6"
SS6B 31	18,5	25		350	343	336	325	309	289	277	264	234	200	6"
SS6B 32	18,5	25		361	354	347	335	319	298	286	272	242	207	6"
SS6B 33	18,5	25		372	365	358	346	329	307	295	281	249	213	6"
SS6B 34	18,5	25		384	376	368	356	339	317	304	289	257	220	6"
SS6B 35	22	30		395	387	379	367	349	326	313	298	264	226	6"
SS6B 36	22	30		406	398	390	377	359	335	322	306	272	233	6"
SS6B 37	22	30		418	409	401	388	369	345	330	315	279	239	6"
SS6B 38	22	30		429	420	412	398	379	354	339	323	287	246	6"
SS6B 39	22	30		440	432	423	409	389	363	348	332	294	252	6"
SS6B 40	22	30		451	443	433	419	399	373	357	340	302	259	6"
SS6B 41	22	30		463	454	444	430	409	382	366	349	310	265	6"
SS6B 42	26,5	35		474	465	455	440	419	391	375	357	317	272	6"
SS6B 43	26,5	35	485	476	466	450	429	401	384	366	325	278	6"	

### ELECTRICAL DATA AND DIMENSIONS

MODEL	MOTOR *	ELECTRICAL DATA				HORIZONTAL INSTALLATION	L2 mm	L mm	L1 mm	D mm	D1 mm	TOTAL WEIGHT Kg
		P2 NOMINAL		In A	OPERATING BY INVERTER							
		kW	HP									
SS6B 28	6GF	15	20	33,4	●	●	2748	785	1963	141	132	104
	TR6	15	20	32	○	●	2960	997	1963	144	132	122
SS6B 29	6GF	18,5	25	41	●	●	2884	860	2024	141	132	113
	TR6	18,5	25	39	○	●	3081	1057	2024	144	132	129
SS6B 30	6GF	18,5	25	41	●	●	2944	860	2084	141	132	114
	TR6	18,5	25	39	○	●	3141	1057	2084	144	132	130
SS6B 31	6GF	18,5	25	41	●	●	3005	860	2145	141	132	116
	TR6	18,5	25	39	○	●	3202	1057	2145	144	132	132
SS6B 32	6GF	18,5	25	41	●	●	3065	860	2205	141	132	117
	TR6	18,5	25	39	○	●	3262	1057	2205	144	132	133
SS6B 33	6GF	18,5	25	41	●	●	3126	860	2266	141	132	119
	TR6	18,5	25	39	○	●	3323	1057	2266	144	132	135
SS6B 34	6GF	18,5	25	41	●	●	3186	860	2326	141	132	120
	TR6	18,5	25	39	○	●	3383	1057	2326	144	132	136
SS6B 35	6GF	22	30	47	●	●	3307	920	2387	141	132	125,6
	TR6	22	30	49	○	●	3474	1087	2387	144	132	150
SS6B 36	6GF	22	30	47	●	●	3367	920	2447	141	132	126,6
	TR6	22	30	49	○	●	3534	1087	2447	144	132	151
SS6B 37	6GF	22	30	47	●	●	3428	920	2508	141	132	128,6
	TR6	22	30	49	○	●	3595	1087	2508	144	132	153
SS6B 38	6GF	22	30	47	●	●	3488	920	2568	141	132	129,6
	TR6	22	30	49	○	●	3655	1087	2568	144	132	154
SS6B 39	6GF	22	30	47	●	●	3799	920	2879	141	167	161,6
	TR6	22	30	49	○	●	3966	1087	2879	144	167	186
SS6B 40	6GF	22	30	47	●	●	3859	920	2939	141	167	163,6
	TR6	22	30	49	○	●	4026	1087	2939	144	167	188
SS6B 41	6GF	22	30	47	●	●	3920	920	3000	141	167	165,6
	TR6	22	30	49	○	●	4087	1087	3000	144	167	190
SS6B 42	6GF	30	40	61,5	●	●	4110	1050	3060	141	167	182,8
	TR6	26	35	58	○	●	4217	1157	3060	144	167	201
SS6B 43	6GF	30	40	61,5	●	●	4171	1050	3121	141	167	184,8
	TR6	26	35	58	○	●	4278	1157	3121	144	167	203

\* Motor 6GF: 6" canned submersible motors.  
 Motor TR6: 6" rewindable submersible motors.

●	Allowed
○	Only PE2 + PA version

# SS6B

## SUBMERSIBLE PUMPS 6"

The performance curves are based on the kinematic viscosity values = 1 mm<sup>2</sup>/s and density equal to 1000 Kg/m<sup>3</sup>. Curve tolerance according to ISO 9906.

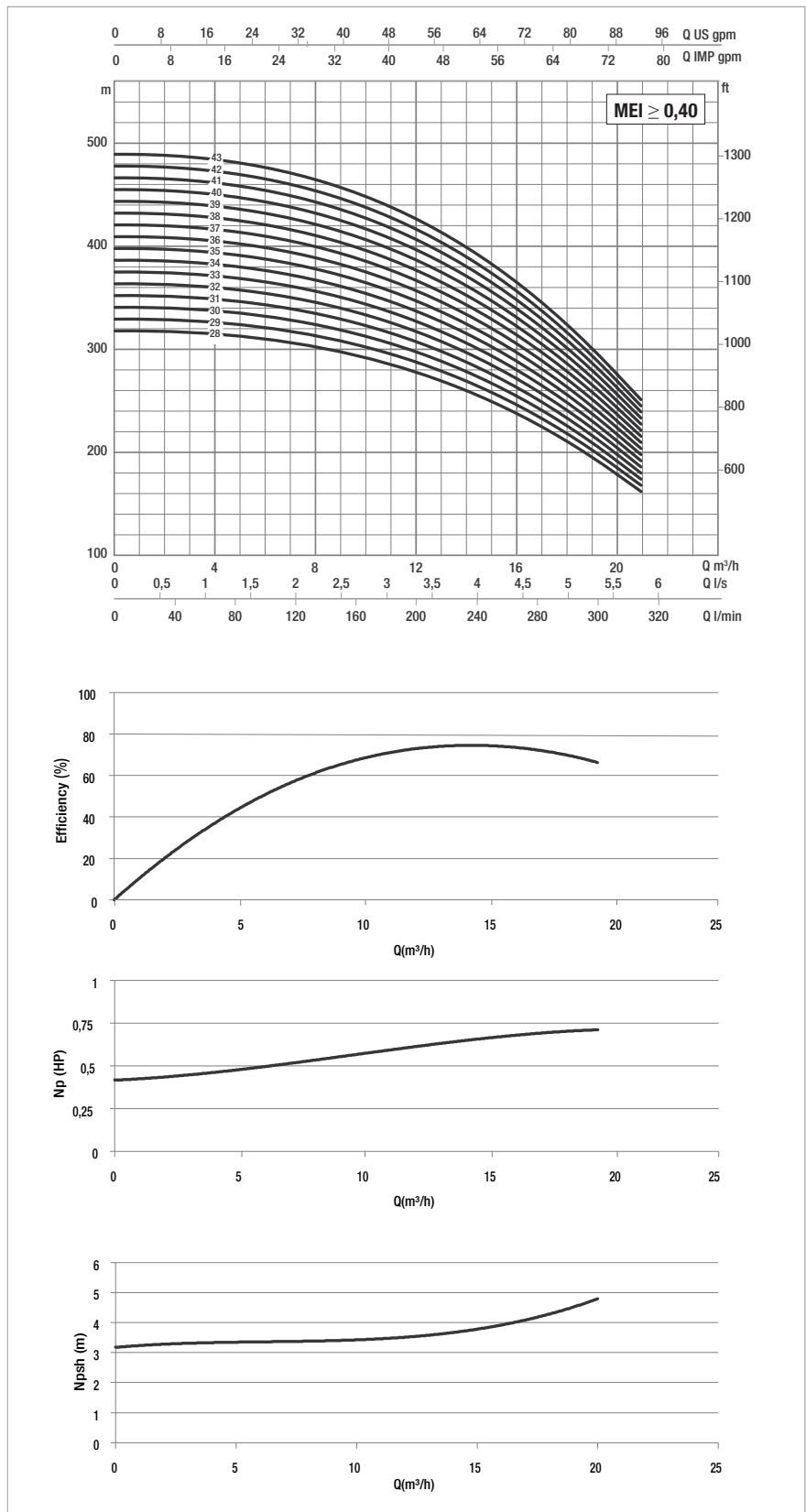
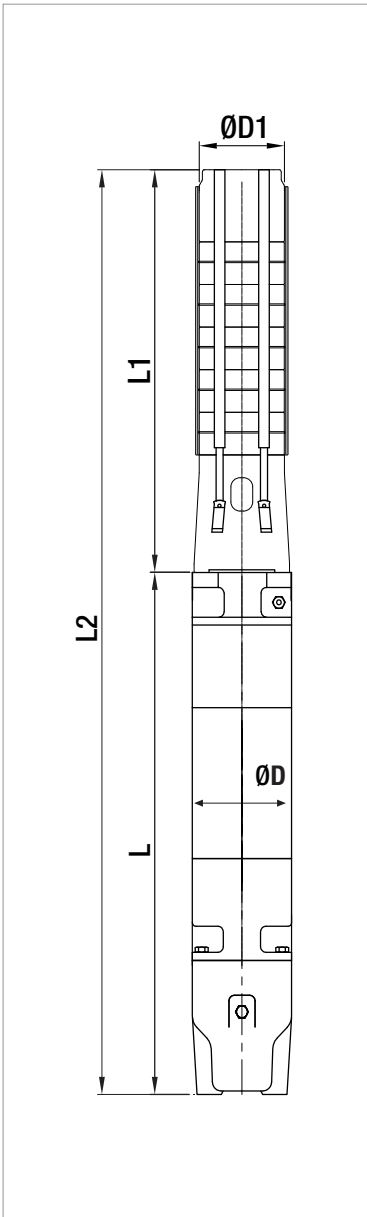

For hydraulic efficiency see pag. 89

### PERFORMANCE 50 Hz - 2 POLES

MODEL	ELECTRICAL DATA		HYDRAULIC DATA											STANDARD MOTOR COUPLING
	P2 NOMINAL		Q=m <sup>3</sup> h	0	6	8	10	12	14	15	16	18	20	
	kW	HP	Q=l/min	0	100	133,3	166,6	200	233,3	250	266,6	300	333,3	
SS6B 44	26,5	35	H (m)	497	487	477	461	439	410	393	374	332	284	6"
SS6B 45	26,5	35		508	498	488	471	449	419	402	383	340	291	6"
SS6B 46	26,5	35		519	509	498	482	459	429	411	391	347	297	6"
SS6B 47	26,5	35		531	520	509	492	469	438	420	400	355	304	6"
SS6B 48	26,5	35		542	531	520	503	479	447	429	408	362	310	6"
SS6B 49	30	40		553	542	531	513	489	457	438	417	370	317	6"
SS6B 50	30	40		564	553	542	524	499	466	447	425	378	323	6"
SS6B 51	30	40		576	564	553	534	509	475	456	434	385	330	6"
SS6B 52	30	40		587	575	563	545	519	485	464	442	393	336	6"
SS6B 53	30	40		598	586	574	555	529	494	473	451	400	343	6"
SS6B 54	30	40		610	597	585	566	539	503	482	459	408	349	6"
SS6B 55	30	40		621	609	596	576	549	512	491	468	415	356	6"
SS6B 56	30	40		632	620	607	587	559	522	500	476	423	362	6"
SS6B 57	37	50		643	631	618	597	569	531	509	485	430	369	6"
SS6B 58	37	50		655	642	628	608	578	540	518	493	438	375	6"
SS6B 59	37	50		666	653	639	618	588	550	527	502	446	381	6"
SS6B 60	37	50		677	664	650	629	598	559	536	510	453	388	6"

### ELECTRICAL DATA AND DIMENSIONS

MODEL	MOTOR *	ELECTRICAL DATA				HORIZONTAL INSTALLATION	L2 mm	L mm	L1 mm	D mm	D1 mm	TOTAL WEIGHT Kg
		P2 NOMINAL		In A	OPERATING BY INVERTER							
		kW	HP									
SS6B 44	6GF	30	40	61,5	●	●	4231	1050	3181	141	167	186,8
	TR6	26	35	58	○	●	4338	1157	3181	144	167	205
SS6B 45	6GF	30	40	61,5	●	●	4292	1050	3242	141	167	188,8
	TR6	26	35	58	○	●	4399	1157	3242	144	167	207
SS6B 46	6GF	30	40	61,5	●	●	4352	1050	3302	141	167	189,8
	TR6	26	35	58	○	●	4459	1157	3302	144	167	208
SS6B 47	6GF	30	40	61,5	●	●	4413	1050	3363	141	167	191,8
	TR6	26	35	58	○	●	4520	1157	3363	144	167	210
SS6B 48	6GF	30	40	61,5	●	●	4473	1050	3423	141	167	193,8
	TR6	26	35	58	○	●	4580	1157	3423	144	167	212
SS6B 49	6GF	30	40	61,5	●	●	4534	1050	3484	141	167	195,8
	TR6	30	40	65	○	●	4696	1212	3484	144	167	219
SS6B 50	6GF	30	40	61,5	●	●	4594	1050	3544	141	167	197,8
	TR6	30	40	65	○	●	4756	1212	3544	144	167	221
SS6B 51	6GF	30	40	61,5	●	●	4655	1050	3605	141	167	198,8
	TR6	30	40	65	○	●	4817	1212	3605	144	167	222
SS6B 52	6GF	30	40	61,5	●	●	4715	1050	3665	141	167	200,8
	TR6	30	40	65	○	●	4877	1212	3665	144	167	224
SS6B 53	6GF	30	40	61,5	●	●	4776	1050	3726	141	167	202,8
	TR6	30	40	65	○	●	4938	1212	3726	144	167	226
SS6B 54	6GF	30	40	61,5	●	●	4836	1050	3786	141	167	204,8
	TR6	30	40	65	○	●	4998	1212	3786	144	167	228
SS6B 55	6GF	30	40	61,5	●	●	4897	1050	3847	141	167	206,8
	TR6	30	40	65	○	●	5059	1212	3847	144	167	230
SS6B 56	6GF	30	40	61,5	●	●	4957	1050	3907	141	167	207,8
	TR6	30	40	65	○	●	5119	1212	3907	144	167	231
SS6B 57	6GF	37	50	79,3	●	●	5148	1180	3968	141	167	221,8
	TR6	37	50	80	○	●	5280	1312	3968	144	167	243
SS6B 58	6GF	37	50	79,3	●	●	5208	1180	4028	141	167	223,8
	TR6	37	50	80	○	●	5340	1312	4028	144	167	245
SS6B 59	6GF	37	50	79,3	●	●	5269	1180	4089	141	167	225,8
	TR6	37	50	80	○	●	5401	1312	4089	144	167	247
SS6B 60	6GF	37	50	79,3	●	●	5329	1180	4149	141	167	227,8
	TR6	37	50	80	○	●	5466	1317	4149	144	167	249

\* Motor 6GF: 6" canned submersible motors.  
 Motor TR: 6" rewindable submersible motors.

●	Allowed
○	Only PE2 + PA version

# SS6B

## SUBMERSIBLE PUMPS 6"

The performance curves are based on the kinematic viscosity values = 1 mm<sup>2</sup>/s and density equal to 1000 Kg/m<sup>3</sup>. Curve tolerance according to ISO 9906.

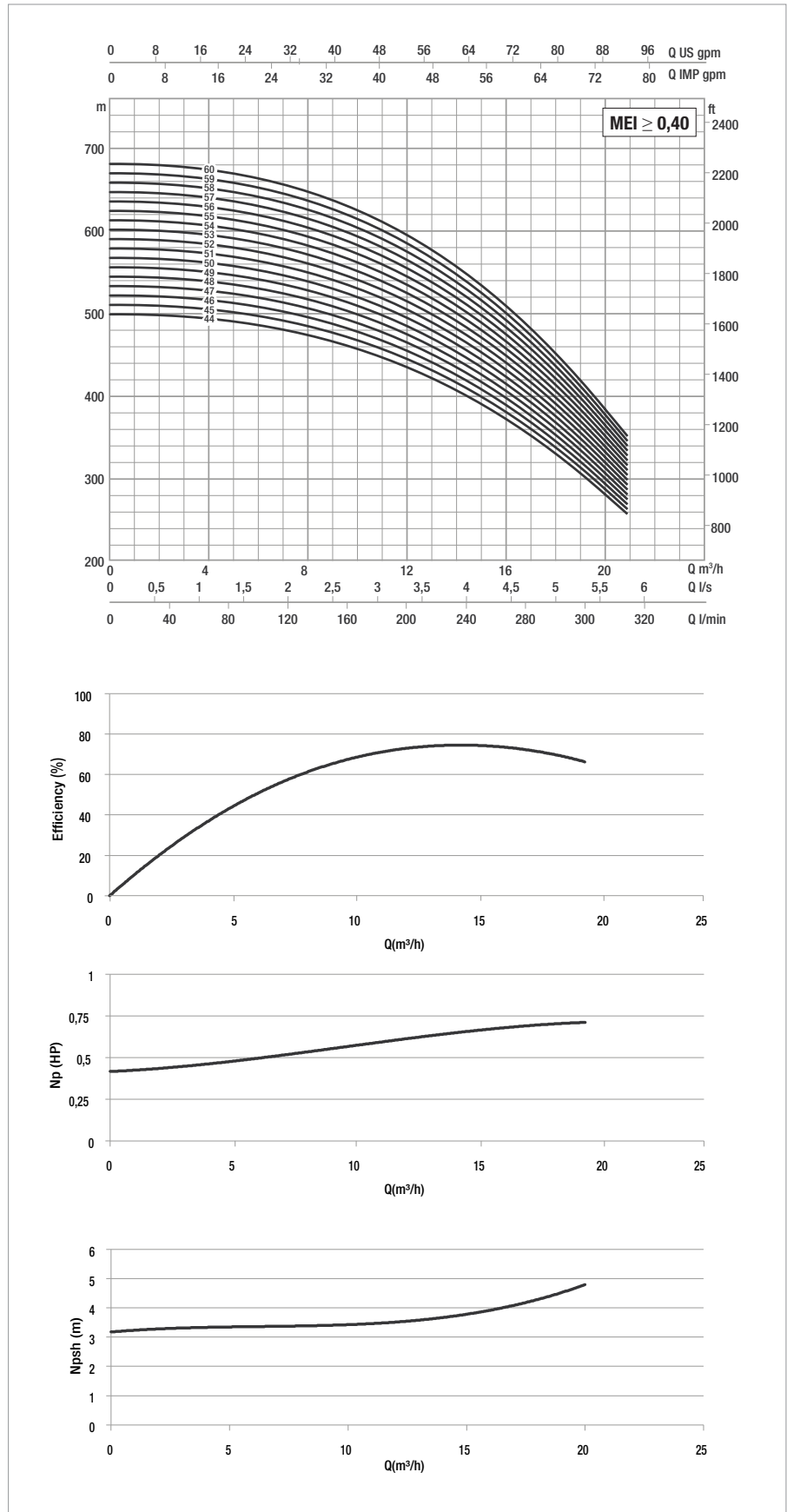
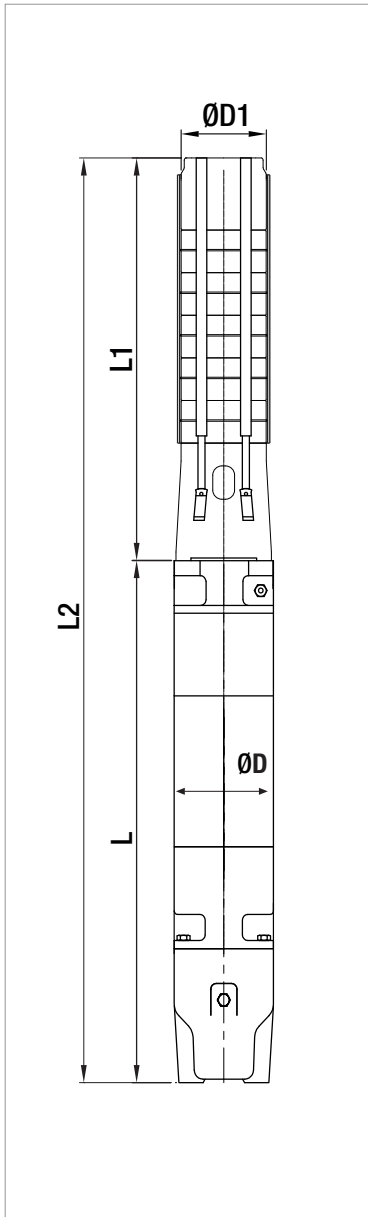

For hydraulic efficiency see pag. 89



### PERFORMANCE 50 Hz - 2 POLES

MODEL	ELECTRICAL DATA		HYDRAULIC DATA											STANDARD MOTOR COUPLING
	P2 NOMINAL		Q=m <sup>3</sup> h	0	6	10	14	18	22	26	30	34	38	
	kW	HP	Q=l/min	0	100	166,6	233,3	300	366,6	433,3	500	566,6	633,3	
SS6C 04	4	5,5	H (m)	47	46	44	43	40	37	34	30	25	20	6"
SS6C 05	5,5	7,5		59	57	55	53	50	47	42	37	32	25	6"
SS6C 06	5,5	7,5		70	69	67	64	60	56	51	45	38	30	6"
SS6C 07	7,5	10		82	80	78	74	70	65	59	52	44	35	6"
SS6C 08	7,5	10		94	92	89	85	80	75	68	60	51	40	6"
SS6C 09	9,2	12,5		105	103	100	96	90	84	76	67	57	45	6"
SS6C 10	9,2	12,5		117	114	111	106	100	93	85	75	63	50	6"
SS6C 11	9,2	12,5		129	126	122	117	110	103	93	82	70	55	6"
SS6C 12	11	15		141	137	133	128	120	112	102	90	76	60	6"
SS6C 13	11	15		152	149	144	138	131	121	110	97	82	65	6"
SS6C 14	15	20		164	160	155	149	141	131	119	105	89	70	6"
SS6C 15	15	20		176	172	166	159	151	140	127	112	95	75	6"
SS6C 16	15	20		187	183	178	170	161	149	136	120	101	80	6"
SS6C 17	15	20		199	195	189	181	171	159	144	127	108	85	6"
SS6C 18	18,5	25		211	206	200	191	181	168	153	135	114	90	6"
SS6C 19	18,5	25		223	217	211	202	191	177	161	142	121	95	6"
SS6C 20	18,5	25		234	229	222	213	201	186	170	150	127	100	6"

### ELECTRICAL DATA AND DIMENSIONS

MODEL	MOTOR *	ELECTRICAL DATA				HORIZONTAL INSTALLATION	L2 mm	L mm	L1 mm	D mm	D1 mm	TOTAL WEIGHT Kg
		P2 NOMINAL		In A	OPERATING BY INVERTER							
		kW	HP									
SS6C 04	6GF	4	5,5	10,6	●	●	1249	600	649	141	132	52,4
SS6C 05	6GF	5,5	7,5	14	●	●	1375	631	744	141	132	57,6
	TR6	5,5	7,5	13	○	●	1551	807	744	144	132	65
SS6C 06	6GF	5,5	7,5	14	●	●	1470	631	839	141	132	59,6
	TR6	5,5	7,5	13	○	●	1646	807	839	144	132	67
SS6C 07	6GF	7,5	10	18	●	●	1594	660	934	141	132	64,2
	TR6	7,5	10	18	○	●	1771	837	934	144	132	72
SS6C 08	6GF	7,5	10	18	●	●	1689	660	1029	141	132	66,2
	TR6	7,5	10	18	○	●	1866	837	1029	144	132	74
SS6C 09	6GF	9,2	12,5	22	●	●	1809	685	1124	141	132	71,6
	TR6	9,2	12,5	21	○	●	1991	867	1124	144	132	78
SS6C 10	6GF	9,2	12,5	22	●	●	1904	685	1219	141	132	73,6
	TR6	9,2	12,5	21	○	●	2086	867	1219	144	132	80
SS6C 11	6GF	9,2	12,5	22	●	●	1999	685	1314	141	132	75,6
	TR6	9,2	12,5	21	○	●	2181	867	1314	144	132	82
SS6C 12	6GF	11	15	25,5	●	●	2139	730	1409	141	132	82
	TR6	11	15	25	○	●	2306	897	1409	144	132	89
SS6C 13	6GF	11	15	25,5	●	●	2234	730	1504	141	132	84
	TR6	11	15	25	○	●	2401	897	1504	144	132	91
SS6C 14	6GF	15	20	33,4	●	●	2384	785	1599	141	132	92
	TR6	13	17,5	29	○	●	2526	927	1599	144	132	98
SS6C 15	6GF	15	20	33,4	●	●	2479	785	1694	141	132	95
	TR6	13	17,5	29	○	●	2621	927	1694	144	132	101
SS6C 16	6GF	15	20	33,4	●	●	2574	785	1789	141	132	97
	TR6	15	20	32	○	●	2786	997	1789	144	132	115
SS6C 17	6GF	15	20	33,4	●	●	2669	785	1884	141	132	99
	TR6	15	20	32	○	●	2881	997	1884	144	132	117
SS6C 18	6GF	18,5	25	41	●	●	2839	860	1979	141	132	109
	TR6	18,5	25	39	○	●	3036	1057	1979	144	132	125
SS6C 19	6GF	18,5	25	41	●	●	2934	860	2074	141	132	111
	TR6	18,5	25	39	○	●	3131	1057	2074	144	132	127
SS6C 20	6GF	18,5	25	41	●	●	3029	860	2169	141	132	113
	TR6	18,5	25	39	○	●	3226	1057	2169	144	132	129

\* Motor 6GF: 6" canned submersible motors  
 Motor TR:6" rewindable submersible motors

●	Allowed
○	Only PE2 + PA version

The performance curves are based on the kinematic viscosity values = 1 mm<sup>2</sup>/s and density equal to 1000 Kg/m<sup>3</sup>. Curve tolerance according to ISO 9906.

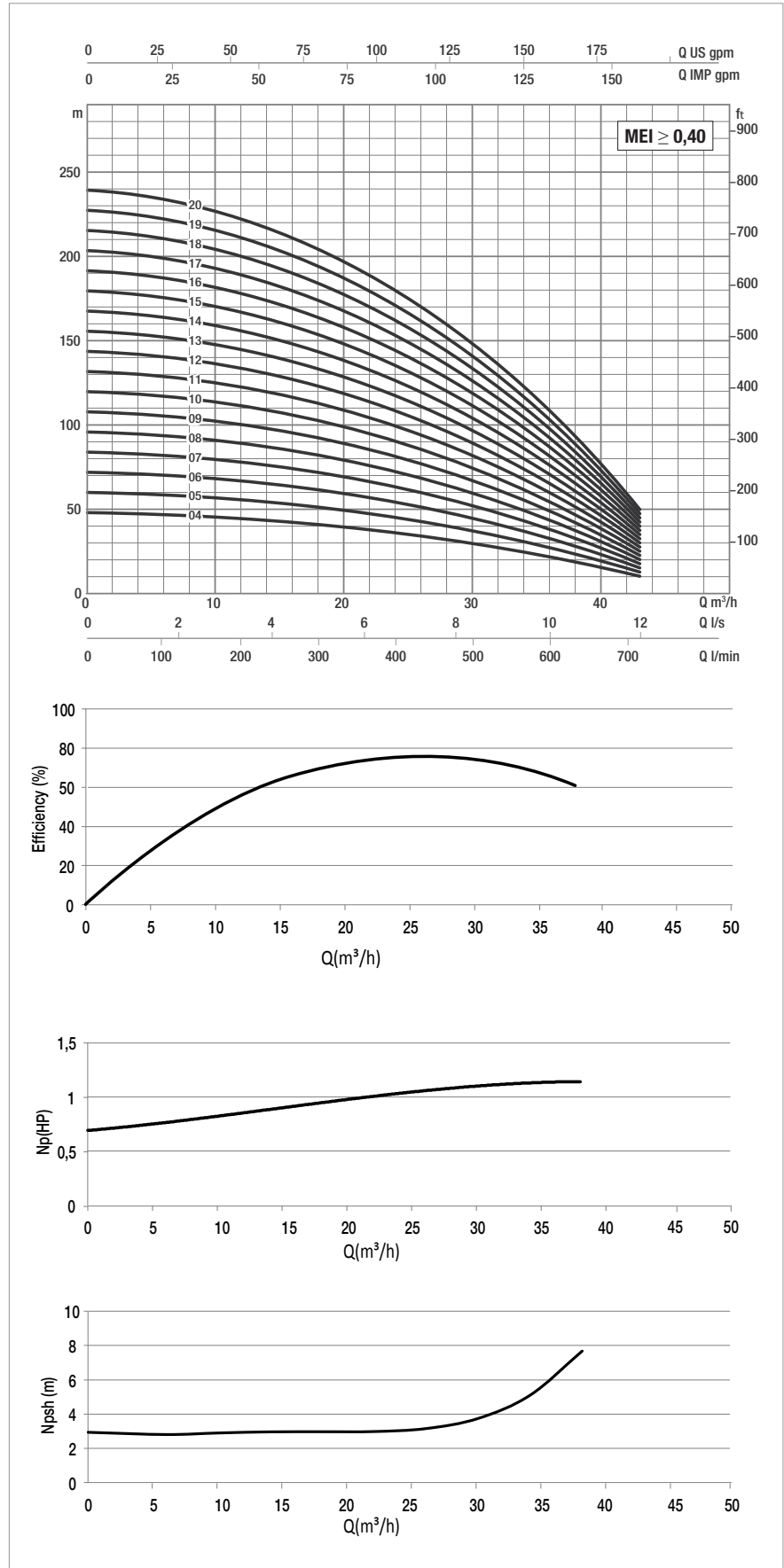
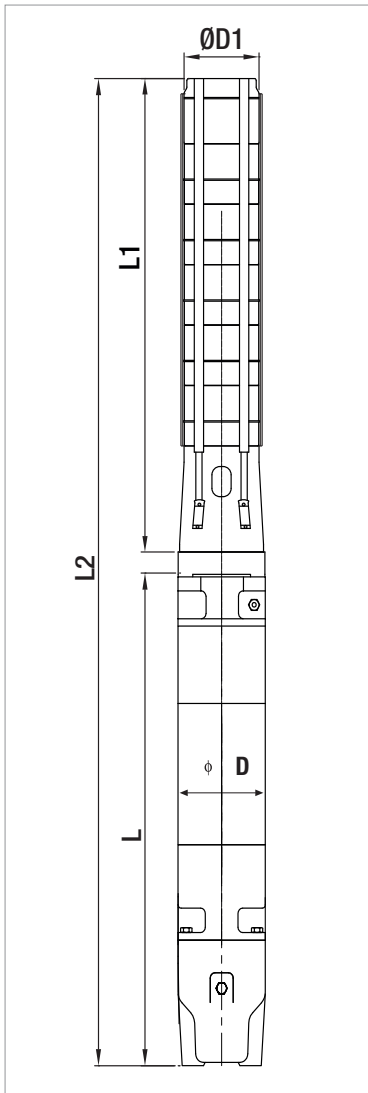

For hydraulic efficiency see pag. 89

## PERFORMANCE 50 Hz - 2 POLES

MODEL	ELECTRICAL DATA		Q=m <sup>3</sup> h Q=l/min	HYDRAULIC DATA										STANDARD MOTOR COUPLING
	P2 NOMINAL			0	6	10	14	18	22	26	30	34	38	
	kW	HP		0	100	166,6	233,3	300	366,6	433,3	500	566,6	633,3	
SS6C 21	18,5	25	H (m)	246	240	233	223	211	196	178	157	133	105	6"
SS6C 22	22	30		258	252	244	234	221	205	187	165	140	110	6"
SS6C 23	22	30		269	263	255	244	231	214	195	172	146	115	6"
SS6C 24	22	30		281	275	266	255	241	224	203	180	152	120	6"
SS6C 25	22	30		293	286	277	266	251	233	212	187	159	125	6"
SS6C 26	22	30		305	298	289	276	261	242	220	195	165	130	6"
SS6C 27	26	35		316	309	300	287	271	252	229	202	171	136	6"
SS6C 28	26	35		328	320	311	298	281	261	237	210	178	141	6"
SS6C 29	26	35		340	332	322	308	291	270	246	217	184	146	6"
SS6C 30	26	35		351	343	333	319	301	280	254	225	190	151	6"
SS6C 31	37	50		363	355	344	330	311	289	263	232	197	156	6"
SS6C 32	37	50		375	366	355	340	321	298	271	240	203	161	6"
SS6C 33	37	50		387	378	366	351	331	308	280	247	209	166	6"
SS6C 34	37	50		398	389	377	361	341	317	288	255	216	171	6"
SS6C 35	37	50		410	401	388	372	351	326	297	262	222	176	6"
SS6C 36	37	50		422	412	400	383	361	336	305	270	228	181	6"
SS6C 37	37	50		433	423	411	393	371	345	314	277	235	186	6"

### ELECTRICAL DATA AND DIMENSIONS

MODEL	MOTOR *	ELECTRICAL DATA				HORIZONTAL INSTALLATION	L2 mm	L mm	L1 mm	D mm	D1 mm	TOTAL WEIGHT Kg
		P2 NOMINAL		In A	OPERATING BY INVERTER							
		kW	HP									
SS6C 21	6GF	18,5	25	41	●	●	3124	860	2264	141	132	115
	TR6	18,5	25	39	○	●	3321	1057	2264	144	132	131
SS6C 22	6GF	22	30	47	●	●	3279	920	2359	141	132	120,6
	TR6	22	30	49	○	●	3446	1087	2359	144	132	145
SS6C 23	6GF	22	30	47	●	●	3374	920	2454	141	132	122,6
	TR6	22	30	49	○	●	3541	1087	2454	144	132	147
SS6C 24	6GF	22	30	47	●	●	3469	920	2549	141	132	124,6
	TR6	22	30	49	○	●	3636	1087	2549	144	132	149
SS6C 25	6GF	22	30	47	●	●	3564	920	2644	141	132	126,6
	TR6	22	30	49	○	●	3731	1087	2644	144	132	151
SS6C 26	6GF	22	30	47	●	●	3659	920	2739	141	132	128,6
	TR6	22	30	49	○	●	3826	1087	2739	144	132	153
SS6C 27	6GF	37	50	61,5	●	●	3884	1050	2834	141	132	146,8
	TR6	26	35	58	○	●	3991	1157	2834	144	132	165
SS6C 28	6GF	37	50	61,5	●	●	3979	1050	2929	141	132	149,8
	TR6	26	35	58	○	●	4086	1157	2929	144	132	168
SS6C 29	6GF	37	50	61,5	●	●	4074	1050	3024	141	132	151,8
	TR6	26	35	58	○	●	4181	1157	3024	144	132	170
SS6C 30	6GF	37	50	61,5	●	●	4169	1050	3119	141	132	153,8
	TR6	26	35	58	○	●	4276	1157	3119	144	132	172
SS6C 31	6GF	37	50	61,5	●	●	4264	1050	3214	141	132	155,8
	TR6	37	50	65	○	●	4426	1212	3214	144	132	179
SS6C 32	6GF	37	50	61,5	●	●	4359	1050	3309	141	132	157,8
	TR6	37	50	65	○	●	4521	1212	3309	144	132	181
SS6C 33	6GF	37	50	61,5	●	●	4454	1050	3404	141	132	159,8
	TR6	37	50	65	○	●	4616	1212	3404	144	132	183
SS6C34	6GF	37	50	61,5	●	●	4549	1050	3499	141	132	161,8
	TR6	37	50	65	○	●	4711	1212	3499	144	132	185
SS6C 35	6GF	37	50	61,5	●	●	4644	1050	3594	141	132	163,8
	TR6	37	50	65	○	●	4806	1212	3594	144	132	187
SS6C 36	6GF	37	50	61,5	●	●	4739	1050	3689	141	132	165,8
	TR6	37	50	65	○	●	4901	1212	3689	144	132	189
SS6C 37	6GF	37	50	79,3	●	●	4964	1180	3784	141	132	179,8
	TR6	37	50	80	○	●	5096	1312	3784	144	132	201

\*Motor 6GF: 6" canned submersible motors  
 Motor TR:6" rewindable submersible motors

●	Allowed
○	Only PE2 + PA version

# SS6C

## SUBMERSIBLE PUMPS 6"

The performance curves are based on the kinematic viscosity values = 1 mm<sup>2</sup>/s and density equal to 1000 Kg/m<sup>3</sup>. Curve tolerance according to ISO 9906.

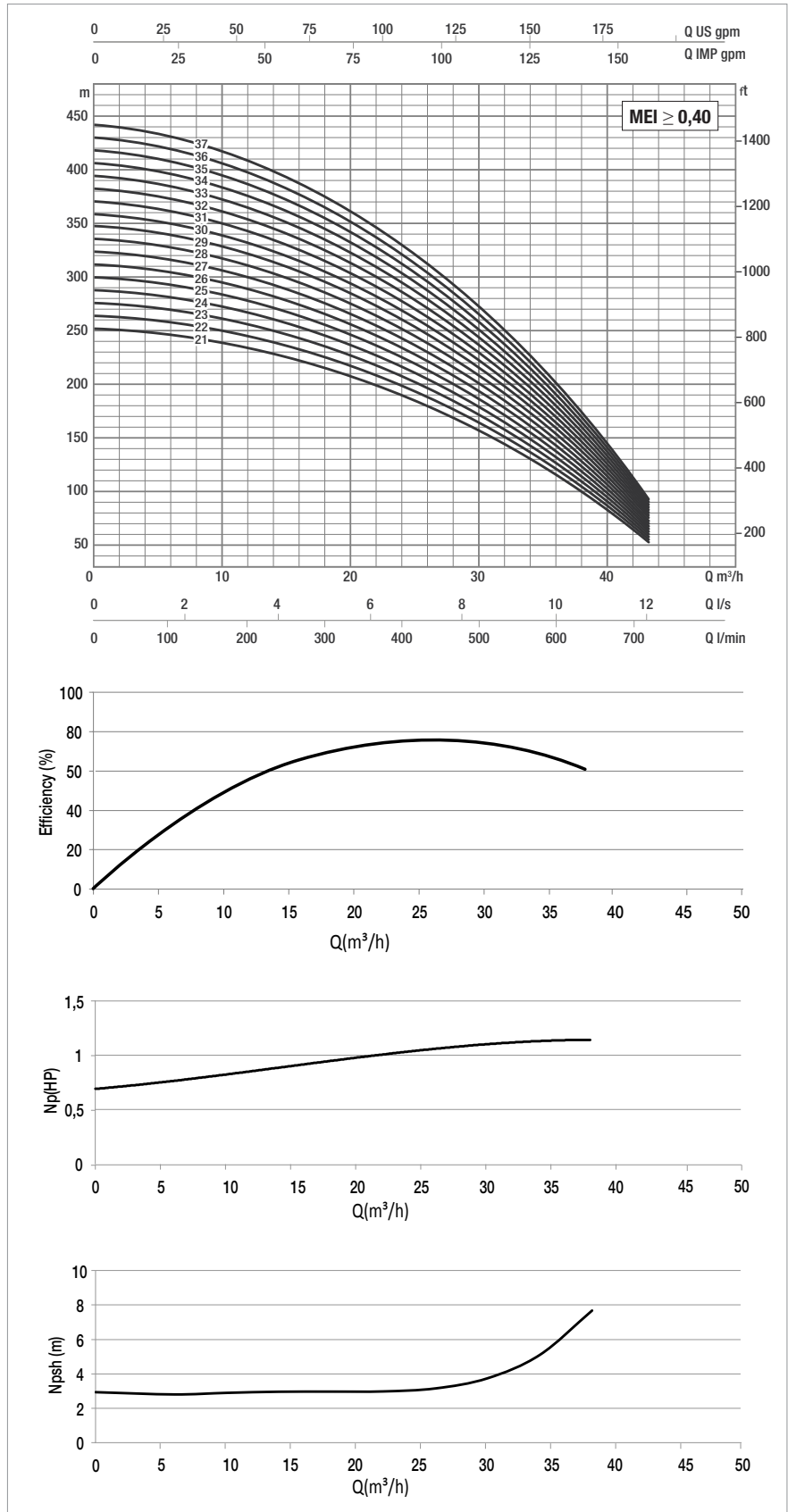
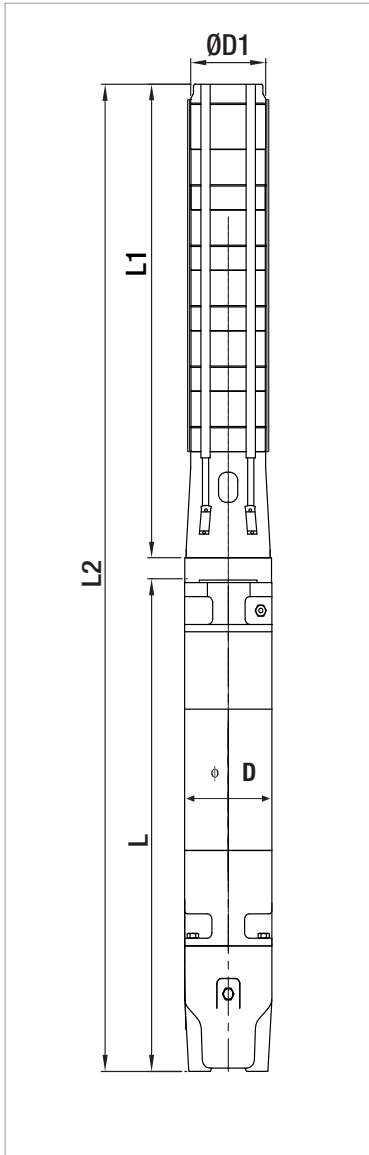

For hydraulic efficiency see pag. 89

### PERFORMANCE 50 Hz - 2 POLES

MODEL	ELECTRICAL DATA		Q=m <sup>3</sup> h Q=l/min	HYDRAULIC DATA										STANDARD MOTOR COUPLING
	P2 NOMINAL			0	6	10	14	18	22	26	30	34	38	
	kW	HP		0	100	166,6	233,3	300	366,6	433,3	500	566,6	633,3	
SS6C 38	37	50	H (m)	445	435	422	404	381	354	322	285	241	191	6"
SS6C 39	37	50		457	446	433	415	392	364	331	292	247	196	6"
SS6C 40	37	50		469	458	444	425	402	373	339	300	254	201	6"
SS6C 41	37	50		480	469	455	436	412	382	348	307	260	206	6"
SS6C 42	37	50		492	481	466	446	422	392	356	315	266	211	6"
SS6C 43	45	60		504	492	477	457	432	401	365	322	273	216	8"
SS6C 44	45	60		515	504	488	468	442	410	373	330	279	221	8"
SS6C 45	45	60		527	515	499	478	452	420	381	337	285	226	8"
SS6C 46	45	60		539	526	511	489	462	429	390	344	292	231	8"
SS6C 47	45	60		551	538	522	500	472	438	398	352	298	236	8"
SS6C 48	45	60		562	549	533	510	482	448	407	359	304	241	8"
SS6C 49	45	60		574	561	544	521	492	457	415	367	311	246	8"
SS6C 50	45	60		586	572	555	532	502	466	424	374	317	251	8"
SS6C 51	45	60		597	584	566	542	512	476	432	382	323	256	8"
SS6C 52	55	75		609	595	577	553	522	485	441	389	330	261	8"
SS6C 53	55	75		621	607	588	563	532	494	449	397	336	266	8"
SS6C 54	55	75	633	618	599	574	542	503	458	404	342	271	8"	

### ELECTRICAL DATA AND DIMENSIONS

MODEL	MOTOR *	ELECTRICAL DATA				HORIZONTAL INSTALLATION	L2 mm	L mm	L1 mm	D mm	D1 mm	TOTAL WEIGHT Kg
		P2 NOMINAL		In A	OPERATING BY INVERTER							
		kW	HP									
SS6C 38	6GF	37	50	79,3	●	●	5059	1180	3879	141	132	203
	TR6	37	50	80	○	●	5191	1312	3879	144	132	222,8
SS6C 39	6GF	37	50	79,3	●	●	5404	1180	4224	141	167	244
	TR6	37	50	80	○	●	5536	1312	4224	144	167	224,8
SS6C 40	6GF	37	50	79,3	●	●	5499	1180	4319	141	167	246
	TR6	37	50	80	○	●	5631	1312	4319	144	167	227,8
SS6C 41	6GF	37	50	79,3	●	●	5594	1180	4414	141	167	249
	TR6	37	50	80	○	●	5726	1312	4414	144	167	230,8
SS6C 42	6GF	37	50	79,9	●	●	5689	1180	4509	141	167	252
	TR6	37	50	80	○	●	5821	1312	4509	144	167	311
SS6C 43	TR8	45	60	92	○	●	5874	1270	4604	141	167	314
SS6C 44	TR8	45	60	92	○	●	5969	1270	4699	141	167	316
SS6C 45	TR8	45	60	92	○	●	6064	1270	4794	141	167	319
SS6C 46	TR8	45	60	92	○	●	6159	1270	4889	141	167	322
SS6C 47	TR8	45	60	92	○	●	6254	1270	4984	141	167	324
SS6C 48	TR8	45	60	92	○	●	6349	1270	5079	141	167	327
SS6C 49	TR8	45	60	92	○	●	6444	1270	5174	141	167	329
SS6C 50	TR8	45	60	92	○	●	6539	1270	5269	141	167	332
SS6C 51	TR8	45	60	92	○	●	6634	1270	5364	141	167	350
SS6C 52	TR8	55	75	109	○	●	6809	1350	5459	141	167	352
SS6C 53	TR8	55	75	109	○	●	6904	1350	5554	141	167	355
SS6C 54	TR8	55	75	109	○	●	6999	1350	5649	141	167	355

\* Motor 6GF: 6" canned submersible motors.

Motor TR: 6" 8" rewindable submersible motors.

●	Allowed
○	Only PE2 + PA version



# SS6C

## SUBMERSIBLE PUMPS 6"

The performance curves are based on the kinematic viscosity values = 1 mm<sup>2</sup>/s and density equal to 1000 Kg/m<sup>3</sup>. Curve tolerance according to ISO 9906.

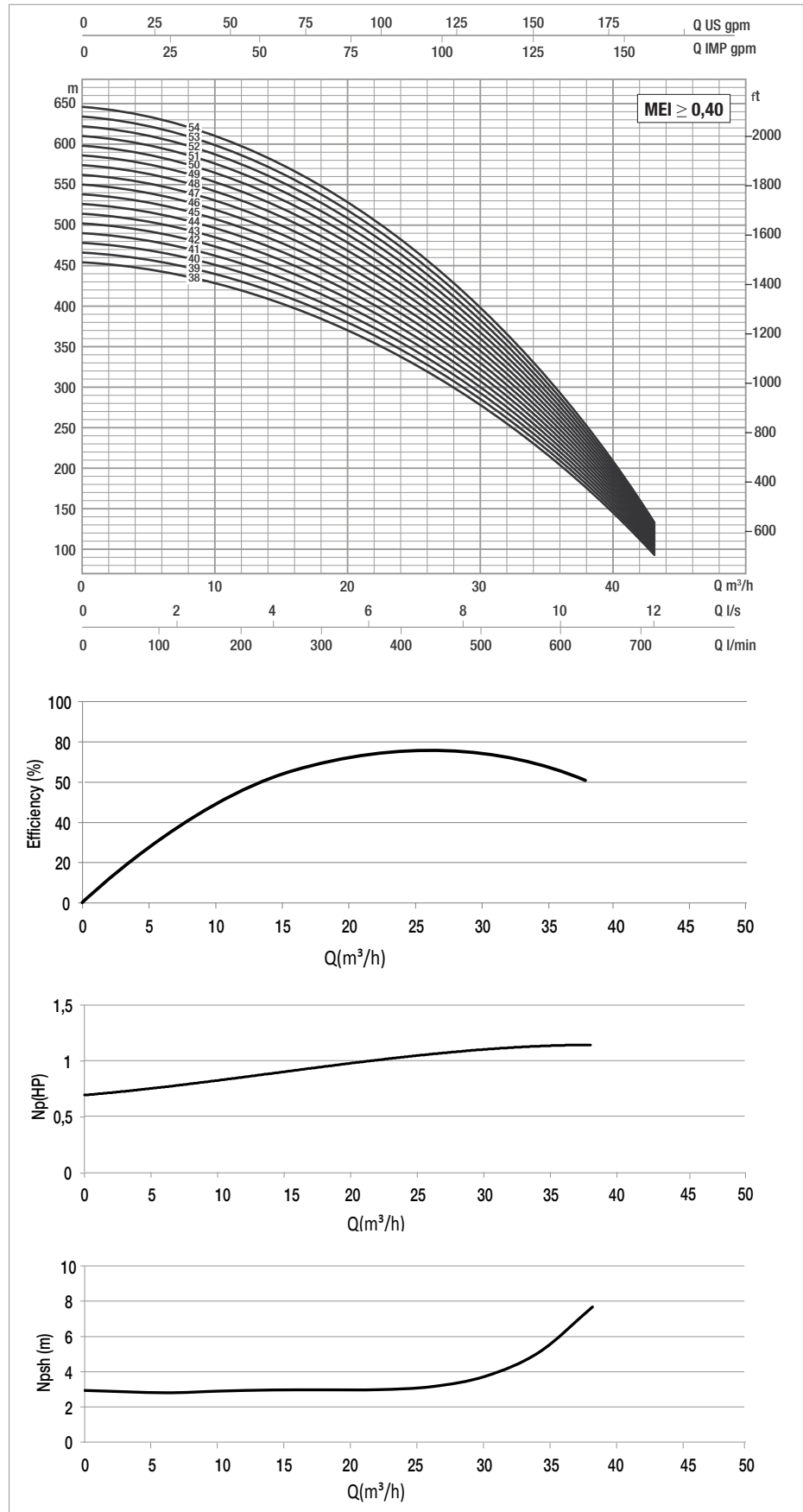
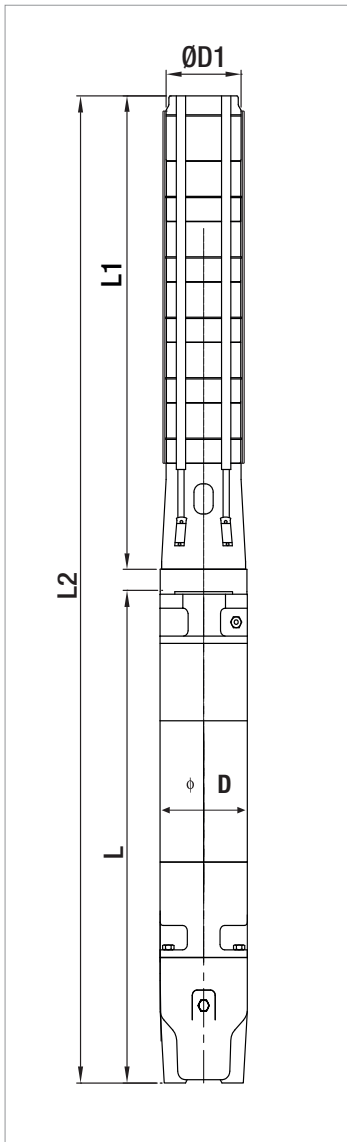

For hydraulic efficiency see pag. 89

## PERFORMANCE 50 Hz - 2 POLES

MODEL	ELECTRICAL DATA		Q=m <sup>3</sup> h Q=l/min	HYDRAULIC DATA										STANDARD MOTOR COUPLING
	P2 NOMINAL			0	20	25	30	35	40	45	50	55	60	
	kW	HP		0	333,3	416,6	500	583,3	666,6	750	833,3	916,6	1000	
SS6D 03	5,5	7,5	H (m)	42	38	36	33	31	29	26	24	20	16	6"
SS6D 04	7,5	10		56	50	47	44	41	38	35	32	27	21	6"
SS6D 05	7,5	10		70	63	59	56	52	48	44	39	34	26	6"
SS6D 06	9,3	12,5		84	75	71	67	62	57	53	47	41	31	6"
SS6D 07	11	15		98	88	83	78	72	67	61	55	47	36	6"
SS6D 08	13	17,5		112	101	95	89	83	77	70	63	54	42	6"
SS6D 09	15	20		126	113	107	100	93	86	79	71	61	47	6"
SS6D 10	18,5	25		140	126	119	111	103	96	88	79	68	52	6"
SS6D 11	18,5	25		154	138	130	122	114	105	97	87	74	57	6"
SS6D 12	22	30		168	151	142	133	124	115	105	95	81	62	6"
SS6D 13	22	30		182	163	154	144	134	125	114	102	88	68	6"
SS6D 14	22	30		196	176	166	155	145	134	123	110	95	73	6"
SS6D 15	26,5	35		210	188	178	167	155	144	132	118	101	78	6"
SS6D 16	26,5	35		224	201	190	178	165	153	141	126	108	83	6"
SS6D 17	30	40		238	214	202	189	176	163	149	134	115	88	6"
SS6D 18	30	40		252	226	213	200	186	172	158	142	122	93	6"
SS6D 19	37	50		266	239	225	211	197	182	167	150	128	99	6"

### ELECTRICAL DATA AND DIMENSIONS

MODEL	MOTOR *	ELECTRICAL DATA				HORIZONTAL INSTALLATION	L2 mm	L mm	L1 mm	D mm	D1 mm	TOTAL WEIGHT Kg
		P2 NOMINAL		In A	OPERATING BY INVERTER							
		kW	HP									
SS6 D3	6GF	5,5	7,5	14	●	●	1237	631	606	141	144	54,6
	TR6	5,5	7,5	13	○	●	1413	807	606	144	144	62
SS6 D4	6GF	7,5	10	18	●	●	1378	660	718	141	144	60,2
	TR6	7,5	10	18	○	●	1555	837	718	144	144	68
SS6 D5	6GF	7,5	10	18	●	●	1490	660	830	141	144	63,2
	TR6	7,5	10	18	○	●	1667	837	830	144	144	71
SS6 D6	6GF	9,2	12,5	22	●	●	1627	685	942	141	144	68,6
	TR6	9,2	12,5	21	○	●	1809	867	942	144	144	75
SS6 D7	6GF	11	15	25,5	●	●	1784	730	1054	141	144	76
	TR6	11	15	25	○	●	1951	897	1054	144	144	83
SS6 D8	6GF	15	20	33,4	●	●	1951	785	1166	141	144	85
	TR6	13	17,5	29	○	●	2093	927	1166	144	144	91
SS6 D9	6GF	15	20	33,4	●	●	2063	785	1278	141	144	87
	TR6	15	20	32	○	●	2275	997	1278	144	144	105
SS6 D10	6GF	18,5	25	41	●	●	2250	860	1390	141	144	98
	TR6	18,5	25	39	○	●	2447	1057	1390	144	144	114
SS6 D11	6GF	18,5	25	41	●	●	2362	860	1502	141	144	101
	TR6	18,5	25	39	○	●	2559	1057	1502	144	144	117
SS6 D12	6GF	22	30	47	●	●	2534	920	1614	141	144	106,6
	TR6	22	30	49	○	●	2701	1087	1614	144	144	131
SS6 D13	6GF	22	30	47	●	●	2646	920	1726	141	144	109,6
	TR6	22	30	49	○	●	2813	1087	1726	144	144	134
SS6 D14	6GF	22	30	47	●	●	2758	920	1838	141	144	112,6
	TR6	22	30	49	○	●	2925	1087	1838	144	144	137
SS6 D15	6GF	30	40	61,5	●	●	3000	1050	1950	141	144	130,8
	TR6	26	35	58	○	●	3107	1157	1950	144	144	149
SS6 D16	6GF	30	40	61,5	●	●	3112	1050	2062	141	144	133,8
	TR6	26	35	58	○	●	3219	1157	2062	144	144	152
SS6 D17	6GF	30	40	61,5	●	●	3224	1050	2174	141	144	135,8
	TR6	30	40	65	○	●	3386	1212	2174	144	144	159
SS6 D18	6GF	30	40	61,5	●	●	3336	1050	2286	141	144	138,8
	TR6	30	40	65	○	●	3498	1212	2286	144	144	162
SS6 D19	6GF	37	50	79,3	○	●	3578	1180	2398	141	144	153,8
	TR6	37	50	80	●	●	3710	1312	2398	144	144	175

\* Motor 6GF: 6" canned submersible motors  
 Motor TR6: 6" rewindable submersible motors

●	Allowed
○	Only PE2 + PA version

# SS6D

## SUBMERSIBLE PUMPS 6"

The performance curves are based on the kinematic viscosity values = 1 mm<sup>2</sup>/s and density equal to 1000 Kg/m<sup>3</sup>. Curve tolerance according to ISO 9906.

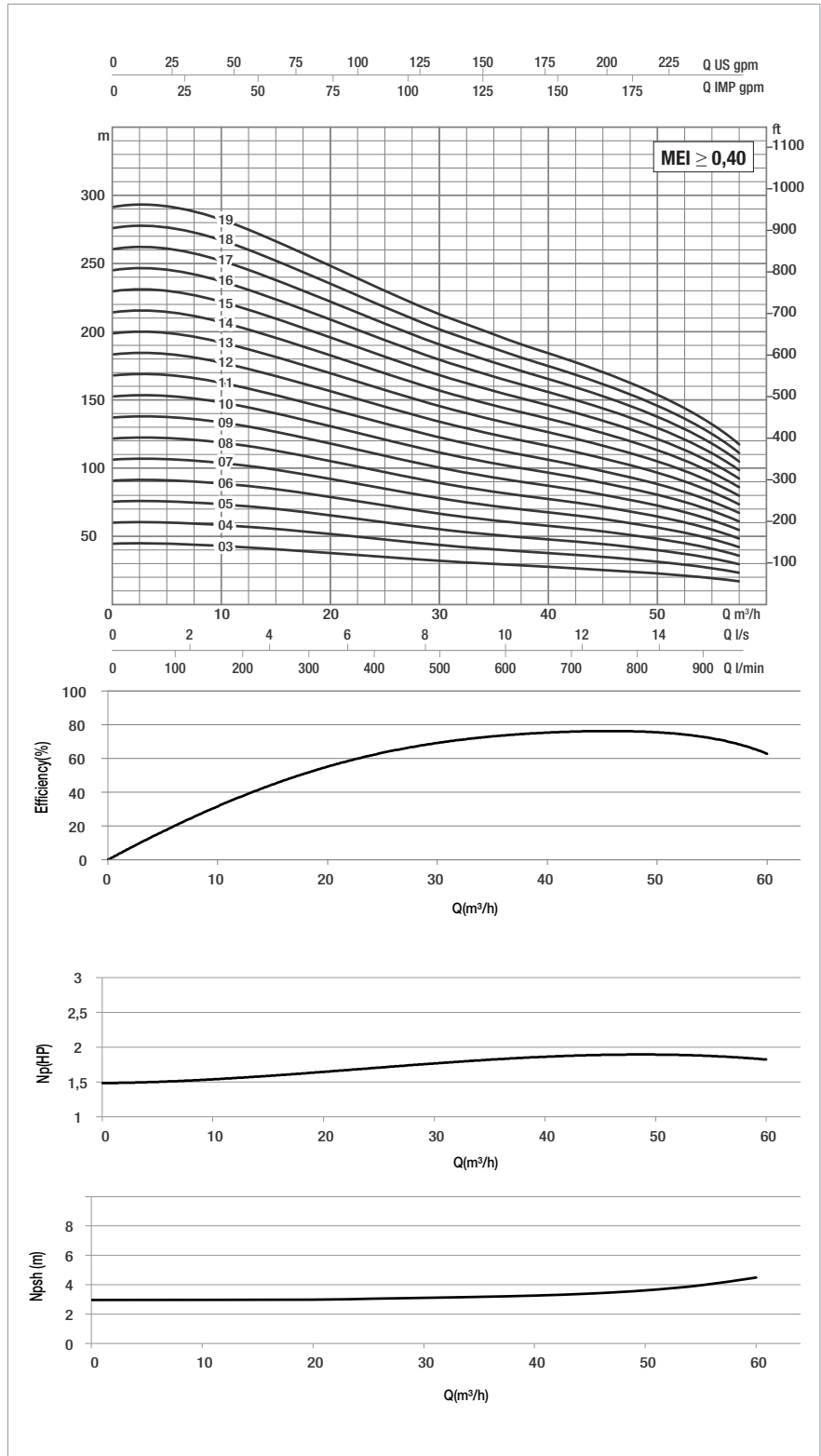
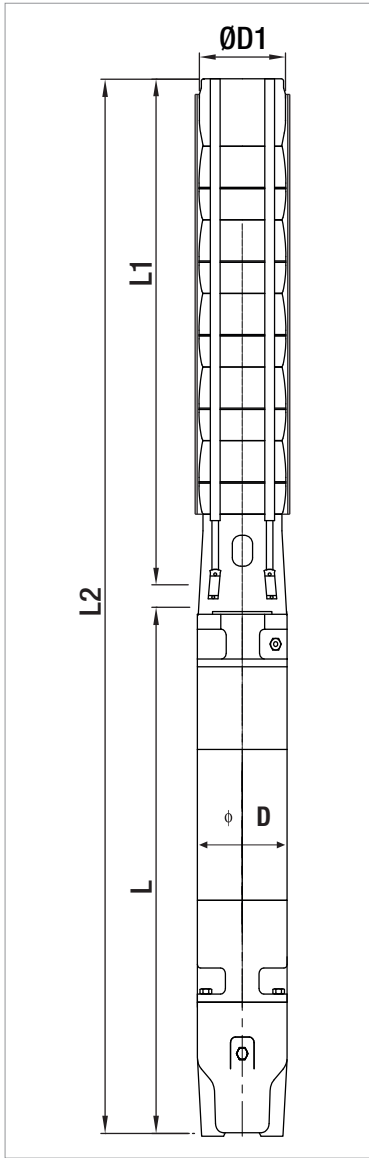

For hydraulic efficiency see pag. 89

### PERFORMANCE 50 Hz - 2 POLES

MODEL	ELECTRICAL DATA		HYDRAULIC DATA											STANDARD MOTOR COUPLING
	P2 NOMINAL		Q=m <sup>3</sup> h	0	20	25	30	35	40	45	50	55	60	
	kW	HP	Q=l/min	0	333,3	416,6	500	583,3	666,6	750	833,3	916,6	1000	
SS6D 20	37	50	H (mt)	280	251	237	222	207	192	176	158	135	104	6"
SS6D 21	37	50		294	264	249	233	217	201	184	166	142	109	6"
SS6D 22	37	50		308	276	261	244	228	211	193	173	149	114	6"
SS6D 23	37	50		322	289	273	255	238	220	202	181	155	119	6"
SS6D 24	45	60		336	302	285	267	248	230	211	189	162	125	8"
SS6D 25	45	60		350	314	296	278	259	239	220	197	169	130	8"
SS6D 26	45	60		364	327	308	289	269	249	228	205	176	135	8"
SS6D 27	45	60		378	339	320	300	279	259	237	213	182	140	8"
SS6D 28	45	60		392	352	332	311	290	268	246	221	189	145	8"
SS6D 29	45	60		406	364	344	322	300	278	255	229	196	151	8"
SS6D 30	45	60		420	377	356	333	310	287	264	237	203	156	8"
SS6D 31	55	75		434	390	368	344	321	297	272	244	209	161	8"
SS6D 32	55	75		448	402	379	355	331	307	281	252	216	166	8"
SS6D 33	55	75		462	415	391	366	341	316	290	260	223	171	8"

### ELECTRICAL DATA AND DIMENSIONS

MODEL	MOTOR *	ELECTRICAL DATA				HORIZONTAL INSTALLATION	L2 mm	L mm	L1 mm	D mm	D1 mm	TOTAL WEIGHT Kg
		P2 NOMINAL		In A	OPERATING BY INVERTER							
		kW	HP									
SS6D 20	6GF	37	50	79,3	●	●	3690	1180	2510	141	144	155,8
	TR6	37	50	80	○	●	3822	1312	2510	144	144	177
SS6D 21	6GF	37	50	79,3	●	●	3802	1180	2622	141	144	158,8
	TR6	37	50	80	○	●	3934	1312	2622	144	144	180
SS6D 22	6GF	37	50	79,3	●	●	3914	1180	2734	141	144	161,8
	TR6	37	50	80	○	●	4046	1312	2734	144	144	183
SS6D 23	6GF	37	50	79,3	●	●	4026	1180	2846	141	144	163,8
	TR6	37	50	80	○	●	4158	1312	2846	144	144	185
SS6D 24	TR8	45	60	92	○	●	4228	1270	2958	192	144	245
SS6D 25	TR8	45	60	92	○	●	4340	1270	3070	192	144	248
SS6D 26	TR8	45	60	92	○	●	4452	1270	3182	192	144	250
SS6D 27	TR8	45	60	92	○	●	4564	1270	3294	192	144	253
SS6D 28	TR8	45	60	92	○	●	4676	1270	3406	192	144	256
SS6D 29	TR8	45	60	92	○	●	4788	1270	3518	192	144	258
SS6D 30	TR8	45	60	92	○	●	4900	1270	3630	192	144	261
SS6D 31	TR8	55	75	109	○	●	5092	1350	3742	192	144	278
SS6D 32	TR8	55	75	109	○	●	5204	1350	3854	192	144	281
SS6D 33	TR8	55	75	109	○	●	5316	1350	3966	192	144	284

\* Motor 6GF: 6" canned submersible motors.

Motor TR: 6" 8" rewindable submersible motors.

●	Allowed
○	Only PE2 + PA version

The performance curves are based on the kinematic viscosity values = 1 mm<sup>2</sup>/s and density equal to 1000 Kg/m<sup>3</sup>. Curve tolerance according to ISO 9906.

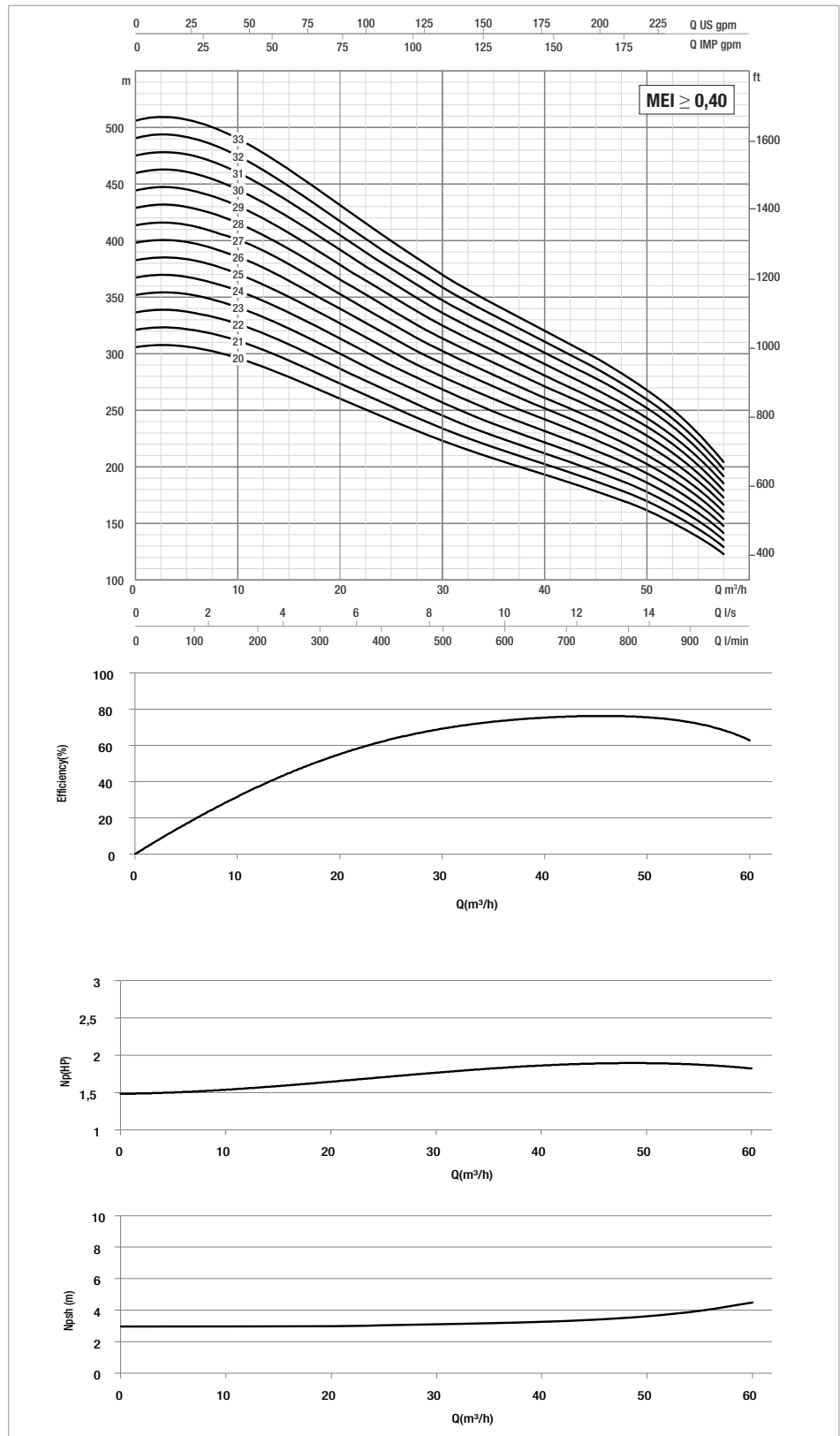
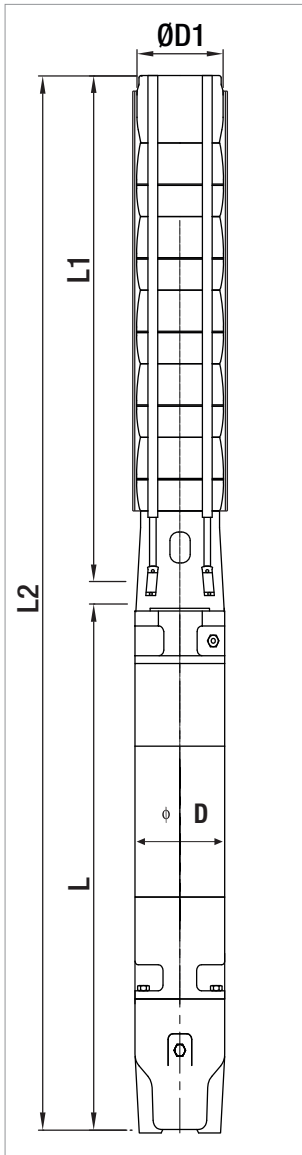

For hydraulic efficiency see pag. 89

## PERFORMANCE 50 Hz - 2 POLES

MODEL	ELECTRICAL DATA		Q=m <sup>3</sup> h Q=l/min	HYDRAULIC DATA										STANDARD MOTOR COUPLING
	P2 NOMINAL			0	20	40	45	50	55	60	65	70	75	
	kW	HP		0	333,3	666,6	750	833,3	916,6	1000	1083,3	1166,6	1250	
SS6E 02	4	5,5	H (m)	30	26	21	20	19	18	17	15	14	11	6"
SS6E 03	5,5	7,5		45	38	31	30	28	27	25	23	20	17	6"
SS6E 04	7,5	10		60	51	42	40	38	36	33	31	27	23	6"
SS6E 05	9,2	12,5		75	64	52	50	47	45	42	38	34	28	6"
SS6E 06	11	15		90	77	62	59	57	54	50	46	41	34	6"
SS6E 07	13	17,5		105	90	73	69	66	63	59	54	48	40	6"
SS6E 08	15	20		120	103	83	79	75	71	67	61	54	45	6"
SS6E 09	18,5	25		135	115	94	89	85	80	75	69	61	51	6"
SS6E 10	18,5	25		150	128	104	99	94	89	84	77	68	56	6"
SS6E 11	22	30		165	141	115	109	104	98	92	85	75	62	6"
SS6E 12	22	30		180	154	125	119	113	107	100	92	82	68	6"
SS6E 13	26	35		195	167	135	129	123	116	109	100	88	73	6"
SS6E 14	26	35		210	180	146	139	132	125	117	108	95	79	6"
SS6E 15	30	40		225	192	156	149	141	134	126	115	102	85	6"
SS6E 16	30	40		240	205	167	159	151	143	134	123	109	90	6"
SS6E 17	30	40		255	218	177	169	160	152	142	131	116	96	6"



### ELECTRICAL DATA AND DIMENSIONS

MODEL	MOTOR *	ELECTRICAL DATA				HORIZONTAL INSTALLATION	L2 mm	L mm	L1 mm	D mm	D1 mm	TOTAL WEIGHT Kg
		P2 NOMINAL		In A	OPERATING BY INVERTER							
		kW	HP									
SS6E 02	6GF	4	5,5	10,6	●	●	1094	600	494	141	144	49,4
SS6E 03	6GF	5,5	7,5	14	●	●	1237	631	606	141	144	54,6
	TR6	5,5	7,5	13	○	●	1413	807	606	144	144	62
SS6E 04	6GF	7,5	10	18	●	●	1378	660	718	141	144	60,2
	TR6	7,5	10	18	○	●	1555	837	718	144	144	68
SS6E 05	6GF	9,2	12,5	22	●	●	1515	685	830	141	144	66,6
	TR6	9,2	12,5	21	○	●	1697	867	830	144	144	73
SS6E 06	6GF	11	15	25,5	●	●	1672	730	942	141	144	73
	TR6	11	15	25	○	●	1839	897	942	144	144	80
SS6E 07	6GF	15	20	33,4	●	●	1839	785	1054	141	144	82
	TR6	13	17,5	29	○	●	1981	927	1054	144	144	88
SS6E 08	6GF	15	20	33,4	●	●	1951	785	1166	141	144	85
	TR6	15	20	32	○	●	2163	997	1166	144	144	103
SS6E 09	6GF	18,5	25	41	●	●	2138	860	1278	141	144	95
	TR6	18,5	25	39	○	●	2335	1057	1278	144	144	111
SS6E 10	6GF	18,5	25	41	●	●	2250	860	1390	141	144	98
	TR6	18,5	25	39	○	●	2447	1057	1390	144	144	114
SS6E 11	6GF	22	30	47	●	●	2422	920	1502	141	144	104,6
	TR6	22	30	49	○	●	2589	1087	1502	144	144	129
SS6E 12	6GF	22	30	47	●	●	2534	920	1614	141	144	106,6
	TR6	22	30	49	○	●	2701	1087	1614	144	144	131
SS6E 13	6GF	30	35	61,5	●	●	2776	1050	1726	141	144	125,8
	TR6	26	35	58	○	●	2883	1157	1726	144	144	144
SS6E 14	6GF	30	35	61,5	●	●	2888	1050	1838	141	144	128,8
	TR6	26	35	58	○	●	2995	1157	1838	144	144	147
SS6E 15	6GF	30	40	61,5	●	●	3000	1050	1950	141	144	130,8
	TR6	30	40	65	○	●	3162	1212	1950	144	144	154
SS6E 16	6GF	30	40	61,5	●	●	3112	1050	2062	141	144	133,8
	TR6	30	40	65	○	●	3274	1212	2062	144	144	157
SS6E 17	6GF	30	40	61,5	●	●	3224	1050	2174	141	144	136,8
	TR6	30	40	65	○	●	3386	1212	2174	144	144	160

\* Motor 6GF: 6" canned submersible motors  
 Motor TR:6" rewindable submersible motors

●	Allowed
○	Only PE2 + PA version

# SS6E

## SUBMERSIBLE PUMPS 6"

The performance curves are based on the kinematic viscosity values = 1 mm<sup>2</sup>/s and density equal to 1000 Kg/m<sup>3</sup>. Curve tolerance according to ISO 9906.

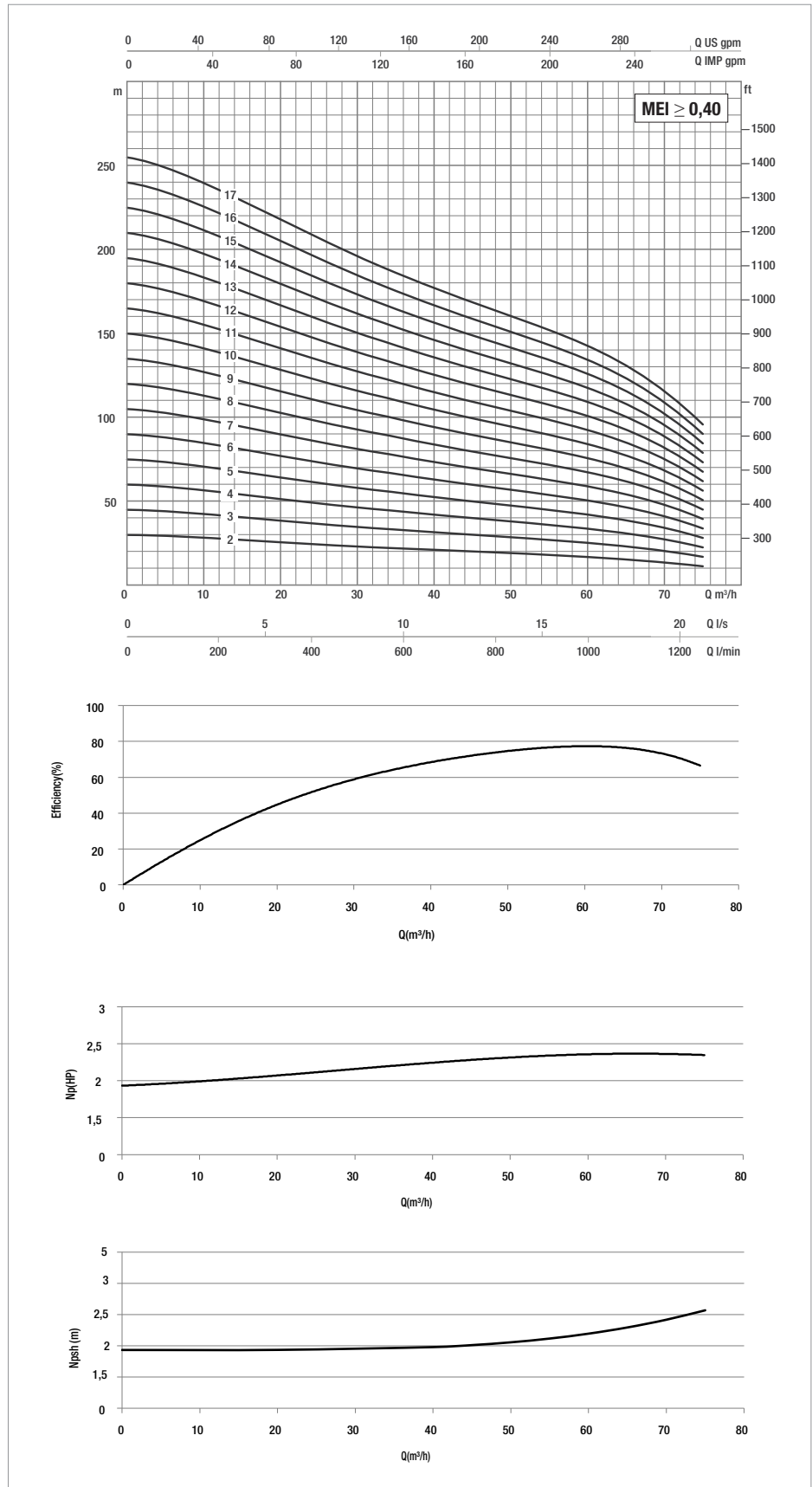
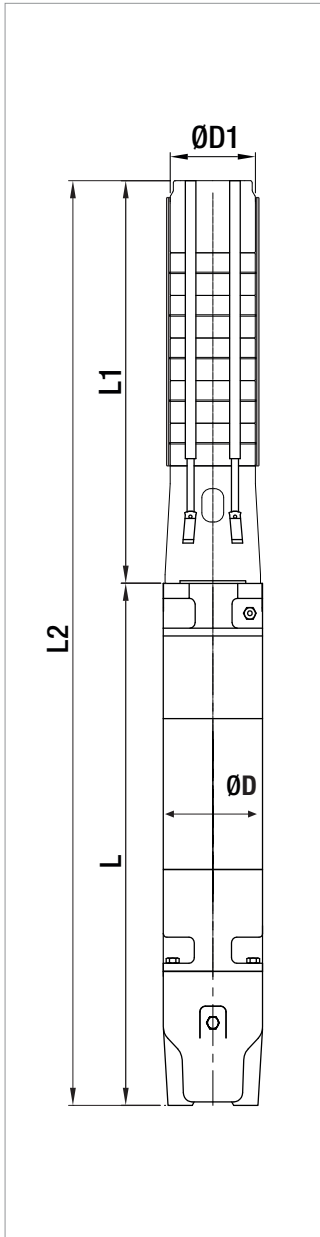

For hydraulic efficiency see pag. 89

### PERFORMANCE 50 Hz - 2 POLES

MODEL	ELECTRICAL DATA		HYDRAULIC DATA											STANDARD MOTOR COUPLING
	P2 NOMINAL		Q=m <sup>3</sup> h	0	20	40	45	50	55	60	65	70	75	
	kW	HP	Q=l/min	0	333,3	666,6	750	833,3	916,6	1000	1083,3	1166,6	1250	
SS6E 18	37	50	H (m)	270	231	187	178	170	161	151	138	122	102	6"
SS6E 19	37	50		285	244	198	188	179	170	159	146	129	107	6"
SS6E 20	37	50		300	257	208	198	189	179	167	154	136	113	6"
SS6E 21	37	50		315	269	219	208	198	188	176	161	143	119	6"
SS6E 22	45	60		330	282	229	218	207	197	184	169	150	124	8"
SS6E 23	45	60		345	295	239	228	217	205	193	177	157	130	8"
SS6E 24	45	60		360	308	250	238	226	214	201	184	163	135	8"
SS6E 25	55	75		375	321	260	248	236	223	209	192	170	141	8"
SS6E 26	55	75		390	334	271	258	245	232	218	200	177	147	8"
SS6E 27	55	75		405	346	281	268	255	241	226	208	184	152	8"
SS6E 28	55	75		420	359	292	278	264	250	234	215	191	158	8"
SS6E 29	55	75		435	372	302	287	273	259	243	223	197	164	8"
SS6E 30	55	75		450	385	312	297	283	268	251	231	204	169	8"

### ELECTRICAL DATA AND DIMENSIONS

MODEL	MOTOR *	ELECTRICAL DATA				HORIZONTAL INSTALLATION	L2 mm	L mm	L1 mm	D mm	D1 mm	TOTAL WEIGHT Kg
		P2 NOMINAL		In A	OPERATING BY INVERTER							
		kW	HP									
SS6E 18	6GF	37	50	79,3	●	●	3466	1180	2286	141	144	150,8
	TR6	37	50	80	○	●	3598	1312	2286	144	144	172
SS6E 19	6GF	37	50	79,3	●	●	3578	1180	2398	141	144	153,8
	TR6	37	50	80	○	●	3710	1312	2398	144	144	175
SS6E 20	6GF	37	50	79,3	●	●	3690	1180	2510	141	144	156,8
	TR6	37	50	80	○	●	3822	1312	2510	144	144	178
SS6E 21	6GF	37	50	79,3	●	●	3802	1180	2622	141	144	158,8
	TR6	37	50	80	○	●	3934	1312	2622	144	144	180
SS6E 22	TR8	45	60	92	○	●	4004	1270	2734	192	144	240
SS6E 23	TR8	45	60	92	○	●	4116	1270	2846	192	144	242
SS6E 24	TR8	45	60	92	○	●	4228	1270	2958	192	144	245
SS6E 25	TR8	55	75	109	○	●	4420	1350	3070	192	144	263
SS6E 26	TR8	55	75	109	○	●	4532	1350	3182	192	144	265
SS6E 27	TR8	55	75	109	○	●	4644	1350	3294	192	144	268
SS6E 28	TR8	55	75	109	○	●	4756	1350	3406	192	144	271
SS6E 29	TR8	55	75	109	○	●	4868	1350	3518	192	144	273
SS6E 30	TR8	55	75	109	○	●	4980	1350	3630	192	144	276

\* Motor 6GF: 6" canned submersible motors.

Motor TR: 6" 8" rewindable submersible motors.

●	Allowed
○	Only PE2 + PA version

# SS6E

## SUBMERSIBLE PUMPS 6"

The performance curves are based on the kinematic viscosity values = 1 mm<sup>2</sup>/s and density equal to 1000 Kg/m<sup>3</sup>. Curve tolerance according to ISO 9906.

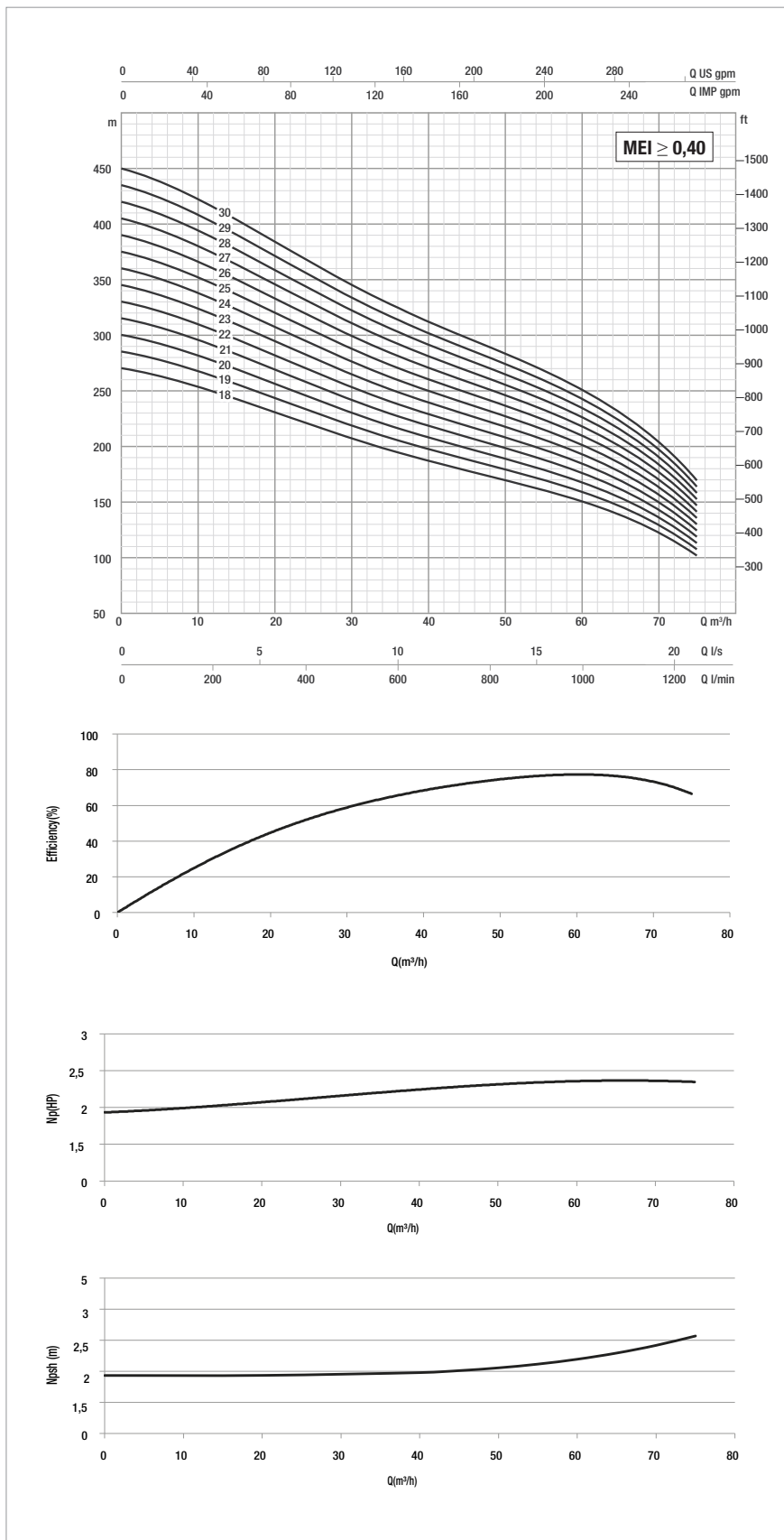
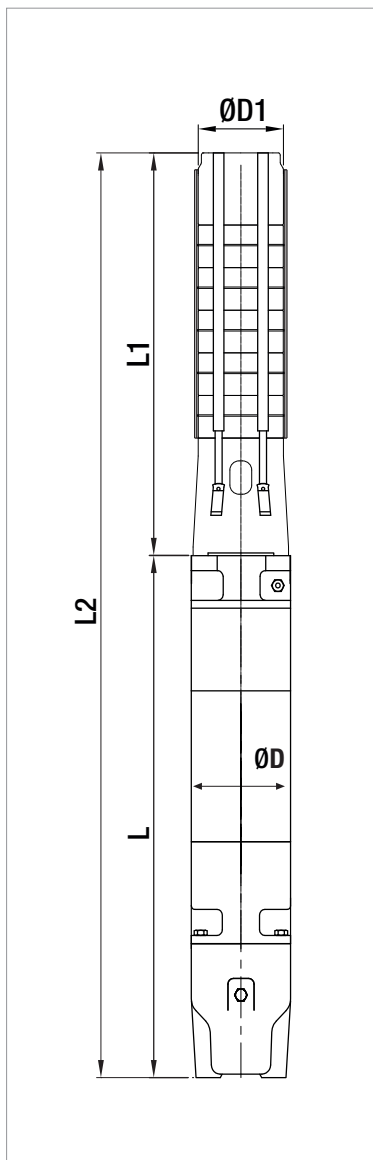

For hydraulic efficiency see pag. 89

**TECHNICAL DATA**

**Performance range:** flow up to 110 m<sup>3</sup>/h and max head of 423 m

**Max. quantity of sand/silt:** 50g/m<sup>3</sup>

**Max. ambient temperature:** 30°C (50°C available on request)

**Outlet connection diameter (inside threaded):** 5"

**Nr of starts:** refer to the motor specification

**Motor Cooling flow:** refer to the motor specification

**Installation:** horizontal or vertical, refer to the motor specification

**APPLICATIONS**

Multistage mixed-flow borehole electric pumps, completely made in stainless steel (AISI 304L or AISI 316 on request), usable for wells from a minimum diameter equal to pump size or greater and capable of developing a wide range of Flows and Heads.

These pumps can be used in a wide range of lifting, distributing, and pressuring application: domestic and general water supply; sprinkler and drip irrigations systems; fire-fighting installations; lowering of groundwater level; industrial supplies as mining, hot springs, autoclaves and tanks.

These pumps are suitable both for standard water and for aggressive water applications by choosing the proper manufacturing material (AISI 304L or AISI 316) both for hydraulic part and motor.

Special version of motors with PE2+PA windings can be used on request for high-temperature water applications up to maximum 50°C.

Pumps can be installed both vertically and horizontally simply by removing the non-return valve and adding a cooling sleeve to the suction case (the only remark is to check the motor applicability to horizontal operations, refer to the motor specifications section).

**CONSTRUCTION FEATURES OF PUMP**

Mixed flow pumps with diffusers, impellers, brackets, suction case and discharge case completely made of stainless steel AISI 304 in order to provide maximum strength, durability, wear and tear resistance.

The impellers are balanced and locked to the shaft with a specially shaped collet and nut coupling, in order to guarantee ease-to-assembly feature and avoid vibration sensitive malfunctions and noise increase during rotation.

Rubber bearings that drive the shaft are water lubricated and have sand channels to make enable the sand particles leave the pump with the pumped liquid (maximum permissible sand content 50 gr/m<sup>3</sup>).

Built-in non returned valve provided in order to minimize local friction losses.

Stainless steel strainer provided in order to prevent particles over a certain size from entering the pump.

Coupling with 6", 8" or 10" motor depending on the power requested by hydraulic part:

- 6GF: 6" canned submersible motor
- TR6: 6" rewindable submersible motor
- TR8: 8" rewindable submersible motor
- TR10: 10" rewindable submersible motor

For inverter application refer to the detailed motor specification.

**ON REQUEST:**

- Pump body stainless steel AISI 316 for aggressive water application
- Impellers stainless steel AISI 316
- Motors in full stainless steel AISI 316 for aggressive water application
- Star/Delta starting version
- Special version of the motor for high temperature application
- Non-standard power coupling

### MATERIALS

N°	Part Name	Material
1	Suction Case	Stainless Steel (AISI 304L)
2	Filter	Stainless Steel (AISI 304L)
3	Suction Case Wear Ring	Bronze (ASTM B145-4A)
4	Pump Shaft	Stainless Steel (AISI 420)
5	Collet	Stainless Steel
6	Impeller Wear Ring	STAINLESS STEEL (AISI 304)
7	Impeller	Stainless Steel (AISI 304L)
8	Diffuser	Stainless Steel (AISI 304L)
9	Rubber Bearing	Rubber
10	Diffuser Wear Ring	Rubber
11	Nut for Stop Ring	Stainless Steel (AISI 304L)
12	Bearing	Rubber
13	Shaft Stopper	Bronze (ASTM B145-4A)
14	Valve	Stainless Steel (AISI 304)
15	Discharge Case	Stainless Steel (AISI 304)
16	TIE ROD	STAINLESS STEEL (AISI 304L)
17	CABLE GUARD	STAINLESS STEEL (AISI 304)
18	TIR ROD NUT	STAINLESS STEEL (AISI 303)
19	NAME PLATE	STAINLESS STEEL (AISI 304)

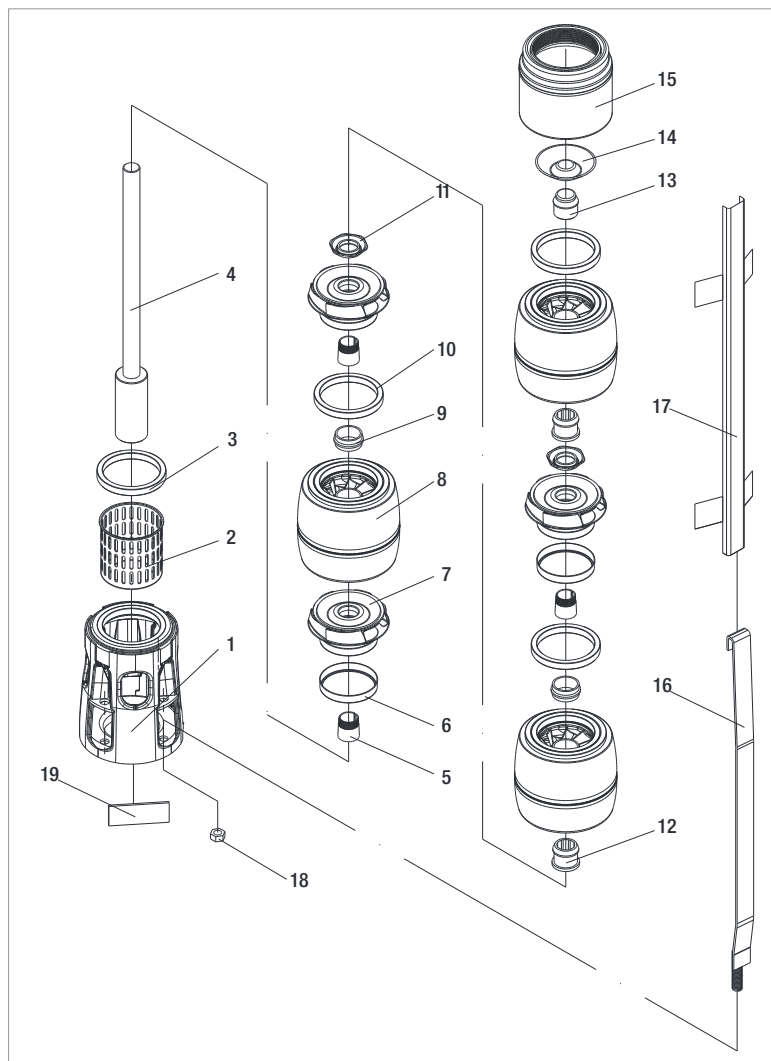

### - Designation Index: (EXAMPLE)

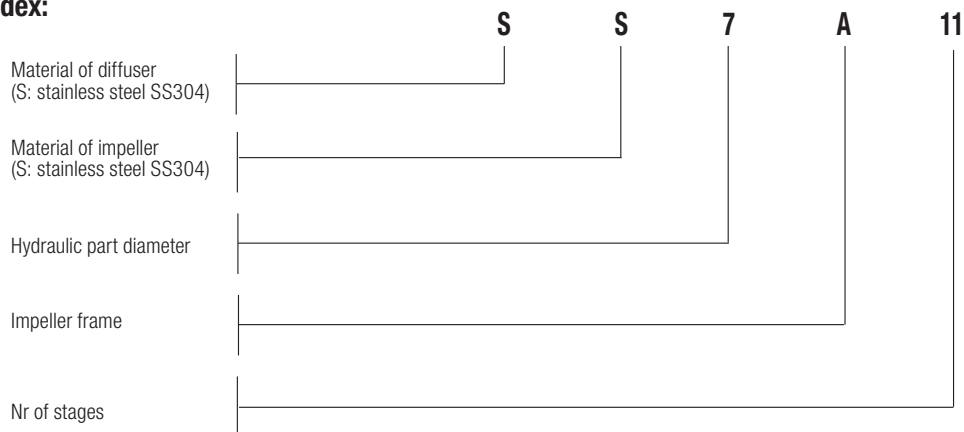

## PERFORMANCE 50 Hz - 2 POLES

MODEL	ELECTRICAL DATA		HYDRAULIC DATA											STANDARD MOTOR COUPLING
	P2 NOMINAL		Q=m <sup>3</sup> h	0	20	30	40	50	60	70	80	90	100	
	kW	HP	Q=l/min	0	333,3	500	666,6	833,3	1000	1166,6	1333,3	1500	1666,6	
SS7A 01	4	5,5	H (mt)	19	19	18	17	16	15	14	12	11	8	6"
SS7A 02	7,5	10		38	37	36	34	32	30	28	25	21	17	6"
SS7A 03	11	15		58	56	54	51	49	45	42	37	32	25	6"
SS7A 04	15	20		77	74	72	69	65	61	56	50	42	33	6"
SS7A 05	18,5	25		96	93	90	86	81	76	69	62	53	41	6"
SS7A 06	22	30		115	111	108	103	97	91	83	74	63	50	6"
SS7A 07	26	35		135	130	126	120	114	106	97	87	74	58	6"
SS7A 08	30	40		154	149	144	137	130	121	111	99	84	66	6"
SS7A 09	37	50		173	167	161	154	146	136	125	111	95	75	6"
SS7A 10	37	50		192	186	179	172	162	152	139	124	105	83	6"
SS7A 11	45	60		211	204	197	189	179	167	153	136	116	91	8"
SS7A 12	45	60		231	223	215	206	195	182	167	149	127	99	8"
SS7A 13	55	75		250	241	233	223	211	197	181	161	137	108	8"
SS7A 14	55	75		269	260	251	240	227	212	195	173	148	116	8"
SS7A 15	55	75		288	278	269	257	244	227	208	186	158	124	8"
SS7A 16	63	85		307	297	287	275	260	243	222	198	169	133	8"
SS7A 17	75	100		327	316	305	292	276	258	236	210	179	141	8"
SS7A 18	75	100		346	334	323	309	292	273	250	223	190	149	8"
SS7A 19	75	100		365	353	341	326	309	288	264	235	200	158	8"
SS7A 20	75	100		384	371	359	343	325	303	278	248	211	166	8"
SS7A 21	75	100		404	390	377	360	341	318	292	260	221	174	8"
SS7A 22	92	125		423	408	395	378	357	334	306	272	232	182	8"



### ELECTRICAL DATA AND DIMENSIONS

MODEL	MOTOR *	ELECTRICAL DATA				HORIZONTAL INSTALLATION	L2 mm	L mm	L1 mm	D mm	D1 mm	TOTAL WEIGHT Kg
		P2 NOMINAL		In A	OPERATING BY INVERTER							
		kW	HP									
SS7A 01	6GF	4	5,5	10,6	●	●	1171	600	571	141	172	65,4
SS7A 02	6GF	7,5	10	18	●	●	1359	660	699	141	172	75,2
	TR6	7,5	10	18	○	●	1536	837	699	144	172	83
SS7A 03	6GF	11	15	25,5	●	●	1557	730	827	141	172	87
	TR6	11	15	25	○	●	1724	897	827	144	172	94
SS7A 04	6GF	15	20	33,4	●	●	1740	785	955	141	172	97
	TR6	15	20	32	○	●	1952	997	955	144	172	115
SS7A 05	6GF	18,5	25	41	●	●	1943	860	1083	141	172	109
	TR6	18,5	25	39	○	●	2140	1057	1083	144	172	125
SS7A 06	6GF	22	30	47	●	●	2131	920	1211	141	172	116,6
	TR6	22	30	49	○	●	2298	1087	1211	144	172	141
SS7A 07	6GF	30	40	61,5	●	●	2389	1050	1339	141	172	136,8
	TR6	26	35	58	○	●	2496	1157	1339	144	172	155
SS7A 08	6GF	30	40	61,5	●	●	2517	1050	1467	141	172	140,8
	TR6	30	40	65	○	●	2679	1212	1467	144	172	164
SS7A 09	6GF	37	50	79,3	●	●	2775	1180	1595	141	172	156,8
	TR6	37	50	80	○	●	2907	1312	1595	144	172	178
SS7A 10	6GF	37	50	79,9	●	●	2903	1180	1723	141	172	160,8
	TR6	37	50	80	○	●	3035	1312	1723	144	172	182
SS7A 11	TR8	45	60	92	○	●	3121	1270	1851	192	172	243
SS7A 12	TR8	45	60	92	○	●	3249	1270	1979	192	172	247
SS7A 13	TR8	55	75	109	○	●	3457	1350	2107	192	172	266
SS7A 14	TR8	55	75	109	○	●	3585	1350	2235	192	172	270
SS7A 15	TR8	55	75	109	○	●	3713	1350	2363	192	172	274
SS7A 16	TR8	63	85	126	○	●	3981	1490	2491	192	172	304
SS7A 17	TR8	75	100	145	○	●	4209	1590	2619	192	172	326
SS7A 18	TR8	75	100	145	○	●	4337	1590	2747	192	172	330
SS7A 19	TR8	75	100	145	○	●	4465	1590	2875	192	172	334
SS7A 20	TR8	75	100	145	○	●	4593	1590	3003	192	172	338
SS7A 21	TR8	75	100	145	○	●	4721	1590	3131	192	172	342
SS7A 22	TR8	92	125	177	○	●	5089	1830	3259	192	172	392

\* Motor 6GF: 6" canned submersible motors.  
 Motor TR: 6"-8" rewindable submersible motors.

●	Allowed
○	Only PE2 + PA version

# SS7A

## SUBMERSIBLE PUMPS 7"

The performance curves are based on the kinematic viscosity values = 1 mm<sup>2</sup>/s and density equal to 1000 Kg/m<sup>3</sup>. Curve tolerance according to ISO 9906.

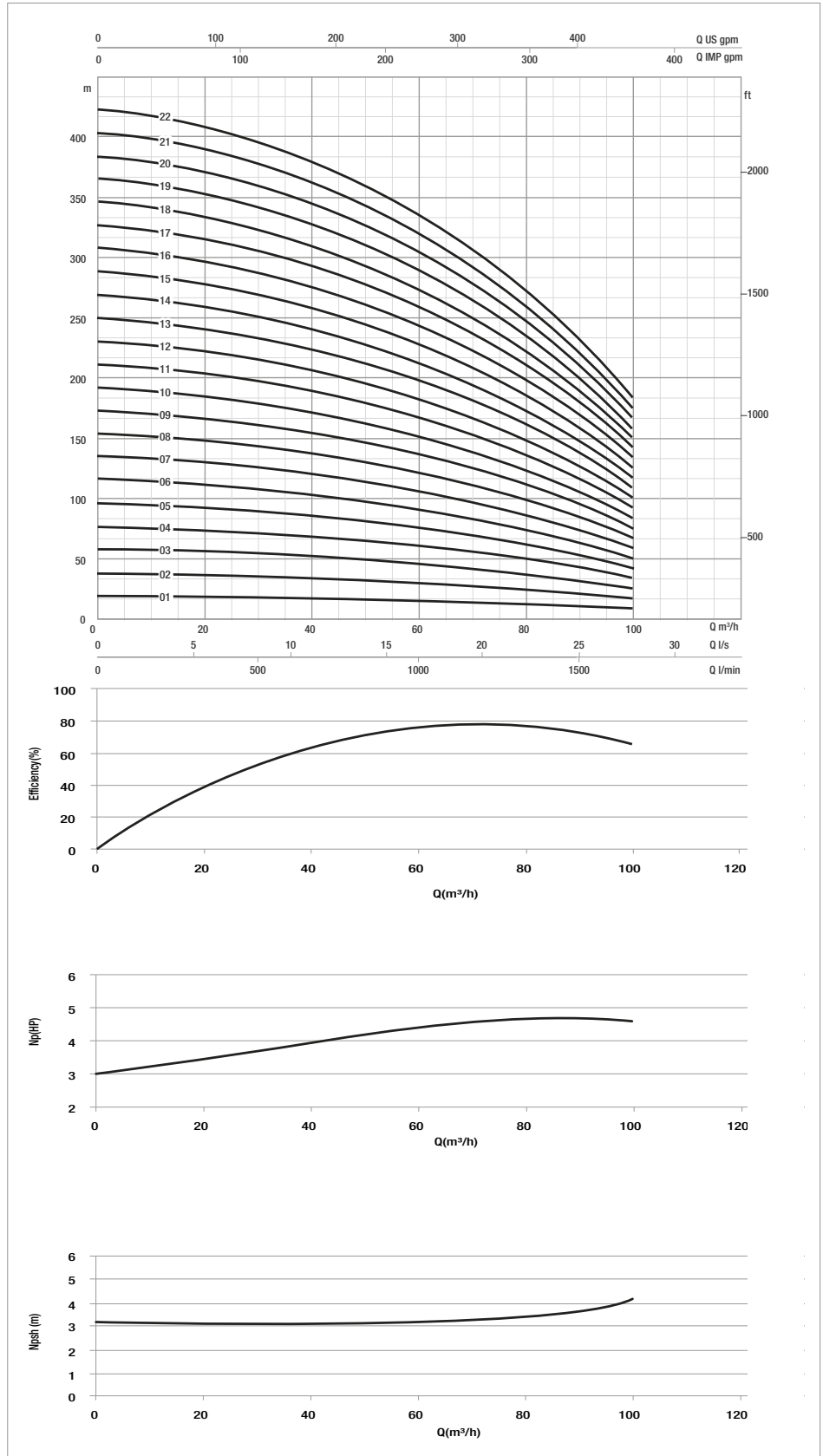
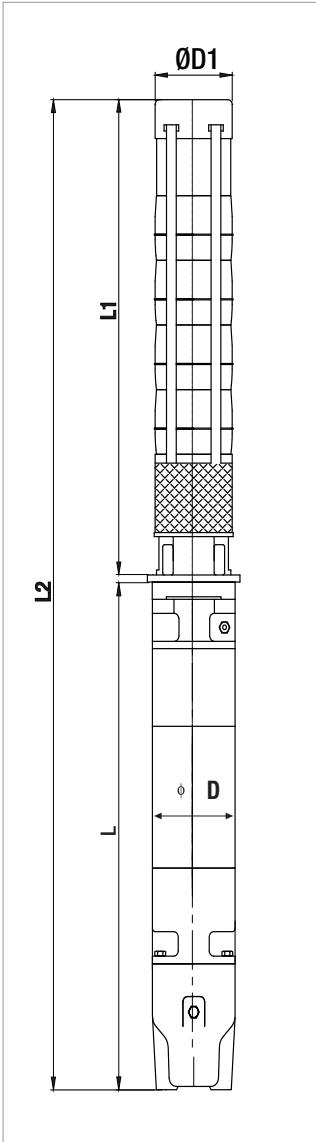



### TECHNICAL DATA

**Performance range:** flow up to 110 m<sup>3</sup>/h and max head of 423 m

**Max. quantity of sand/silt:** 50g/m<sup>3</sup>

**Max. ambient temperature:** 30°C (50°C available on request)

**Outlet connection diameter (inside threaded):** 5"

**Nr of starts:** refer to the motor specification

**Motor Cooling flow:** refer to the motor specification

**Installation:** horizontal or vertical, refer to the motor specification

### APPLICATIONS

Multistage mixed-flow borehole electric pumps, completely made in stainless steel (AISI 304L or AISI 316 on request), usable for wells from a minimum diameter equal to pump size or greater and capable of developing a wide range of Flows and Heads.

These pumps can be used in a wide range of lifting, distributing, and pressuring application: domestic and general water supply; sprinkler and drip irrigations systems; fire-fighting installations; lowering of groundwater level; industrial supplies as mining, hot springs, autoclaves and tanks.

These pumps are suitable both for standard water and for aggressive water applications by choosing the proper manufacturing material (AISI 304L or AISI 316) both for hydraulic part and motor.

Special version of motors with PE2+PA windings can be used on request for high-temperature water applications up to maximum 50°C.

Pumps can be installed both vertically and horizontally simply by removing the non-return valve and adding a cooling sleeve to the suction case (the only remark is to check the motor applicability to horizontal operations, refer to the motor specifications section).

### CONSTRUCTION FEATURES OF PUMP

Mixed flow pumps with diffusers, impellers, brackets, suction case and discharge case completely made of stainless steel AISI 304 in order to provide maximum strength, durability, wear and tear resistance.

The impellers are balanced and locked to the shaft with a specially shaped collet and nut coupling, in order to guarantee ease-to-assembly feature and avoid vibration sensitive malfunctions and noise increase during rotation.

Rubber bearings that drive the shaft are water lubricated and have sand channels to make enable the sand particles leave the pump with the pumped liquid (maximum permissible sand content 50 gr/m<sup>3</sup>).

Built-in non returned valve provided in order to minimize local friction losses.

Stainless steel strainer provided in order to prevent particles over a certain size from entering the pump.

Coupling with 6", 8" or 10" motor depending on the power requested by hydraulic part:

- 6GF: 6" canned submersible motor
- TR6: 6" rewindable submersible motor
- TR8: 8" rewindable submersible motor
- TR10: 10" rewindable submersible motor

For inverter application refer to the detailed motor specification.

### ON REQUEST:

- Pump body stainless steel AISI 316 for aggressive water application
- Impellers stainless steel AISI 316
- Motors in full stainless steel AISI 316 for aggressive water application
- Star/Delta starting version
- Special version of the motor for high temperature application
- Non-standard power coupling

### MATERIALS

N°	Part Name	Material
1	Suction Case	Stainless Steel (AISI 304L)
2	Filter	Stainless Steel (AISI 304L)
3	Suction Case Wear Ring	Bronze (ASTM B145-4A)
4	Pump Shaft	Stainless Steel (AISI 420)
5	Collet	Stainless Steel
6	Impeller Wear Ring	STAINLESS STEEL (AISI 304)
7	Impeller	Stainless Steel (AISI 304L)
8	Diffuser	Stainless Steel (AISI 304L)
9	Rubber Bearing	Rubber
10	Diffuser Wear Ring	Rubber
11	Nut for Stop Ring	Stainless Steel (AISI 304L)
12	Bearing	Rubber
13	Shaft Stopper	Bronze (ASTM B145-4A)
14	Valve	Stainless Steel (AISI 304)
15	Discharge Case	Stainless Steel (AISI 304)
16	TIE ROD	STAINLESS STEEL (AISI 304L)
17	CABLE GUARD	STAINLESS STEEL (AISI 304)
18	TIR ROD NUT	STAINLESS STEEL (AISI 303)
19	NAME PLATE	STAINLESS STEEL (AISI 304)

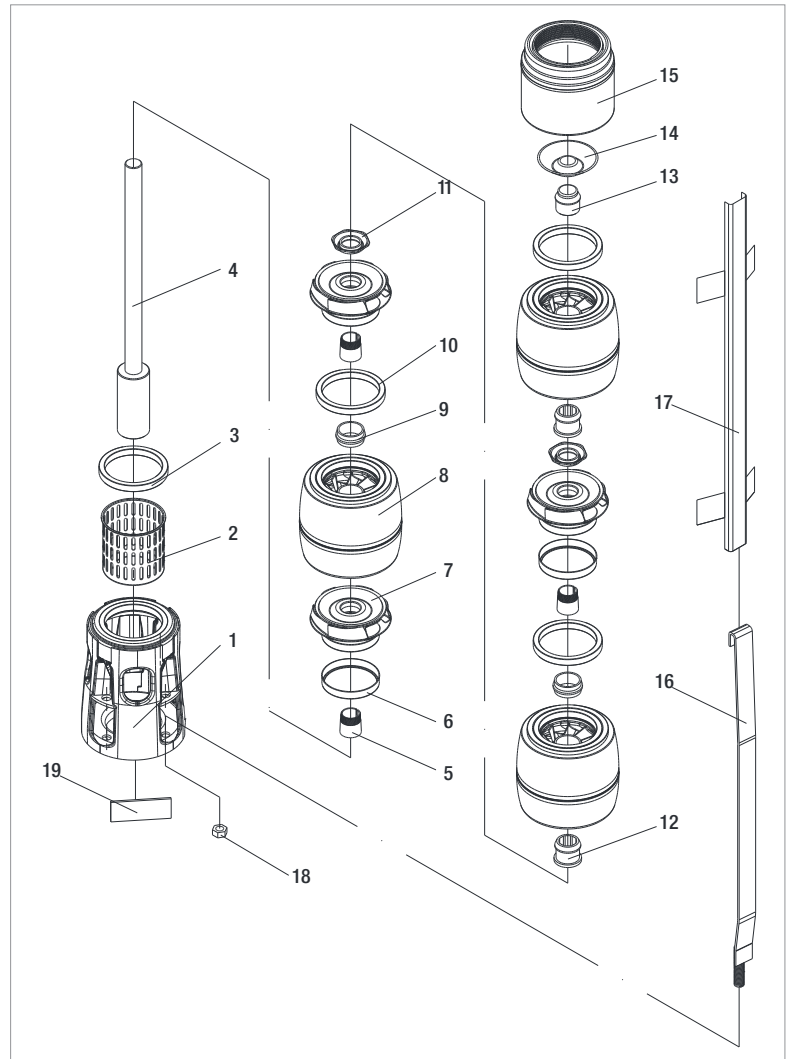

**- Designation Index:**  
(EXAMPLE)

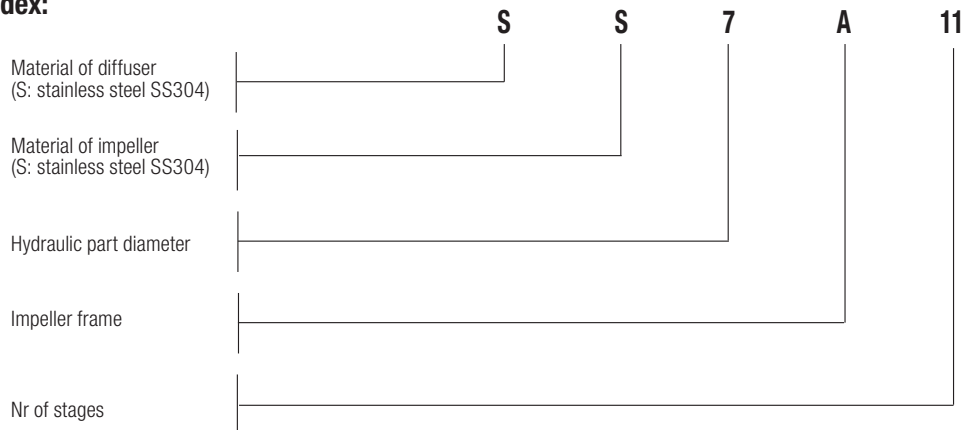

### PERFORMANCE 50 Hz - 2 POLES

MODEL	ELECTRICAL DATA		HYDRAULIC DATA											STANDARD MOTOR COUPLING
	P2 NOMINAL		Q=m <sup>3</sup> h	0	20	40	50	60	70	80	90	100	115	
	kW	HP	Q=l/min	0	333,3	666,6	833,3	1000	1166,6	1333,3	1500	1666,6	1916,6	
SS7B 01	5,5	7,5	H (m)	21	21	20	20	19	18	17	16	14	11	6"
SS7B 02	11	15		43	43	41	39	38	36	34	32	28	21	6"
SS7B 03	15	20		64	64	61	59	56	54	51	47	43	32	6"
SS7B 04	22	30		85	86	81	78	75	72	68	63	57	43	6"
SS7B 05	30	40		106	107	101	98	94	90	85	79	71	54	6"
SS7B 06	37	50		128	128	122	117	113	108	102	95	85	64	6"
SS7B 07	37	50		149	150	142	137	132	126	119	111	100	75	6"
SS7B 08	45	60		170	171	162	156	150	144	136	126	114	86	8"
SS7B 09	45	60		192	193	183	176	169	162	153	142	128	96	8"
SS7B 10	55	75		213	214	203	196	188	180	170	158	142	107	8"
SS7B 11	63	85		234	235	223	215	207	197	187	174	157	118	8"
SS7B 12	75	100		256	257	243	235	225	215	204	190	171	128	8"
SS7B 13	75	100		277	278	264	254	244	233	221	206	185	139	8"
SS7B 14	75	100		298	300	284	274	263	251	238	221	199	150	8"
SS7B 15	92	125		319	321	304	293	282	269	255	237	214	161	8"
SS7B 16	92	125		341	342	325	313	301	287	272	253	228	171	8"
SS7B 17	92	125		362	364	345	332	319	305	289	269	242	182	8"
SS7B 18	110	150		383	385	365	352	338	323	306	285	256	193	8"
SS7B 19	110	150		405	407	385	372	357	341	323	300	271	203	8"
SS7B 20	110	150		426	428	406	391	376	359	340	316	285	214	8"

### ELECTRICAL DATA AND DIMENSIONS

MODEL	MOTOR *	ELECTRICAL DATA				HORIZONTAL INSTALLATION	L2 mm	L mm	L1 mm	D mm	D1 mm	TOTAL WEIGHT Kg
		P2 NOMINAL		In A	OPERATING BY INVERTER							
		kW	HP									
SS7B 01	6GF	5,5	7,5	14	●	●	1202	631	571	141	172	68,6
	TR6	5,5	7,5	13	○	●	1378	807	571	144	172	76
SS7B 02	6GF	11	15	25,5	●	●	1429	730	699	141	172	81,8
	TR6	11	15	25	○	●	1596	897	699	144	172	90
SS7B 03	6GF	15	20	33,4	●	●	1612	785	827	141	172	93
	TR6	15	20	32	○	●	1824	997	827	144	172	111
SS7B 04	6GF	22	30	47	●	●	1875	920	955	141	172	108,6
	TR6	22	30	49	○	●	2042	1087	955	144	172	133
SS7B 05	6GF	30	40	61,5	●	●	2133	1050	1083	141	172	128,8
	TR6	30	40	65	○	●	2295	1212	1083	144	172	152
SS7B 06	6GF	37	50	79,3	●	●	2391	1180	1211	141	172	144,8
	TR6	37	50	80	○	●	2523	1312	1211	144	172	166
SS7B 07	6GF	37	50	79,3	●	●	2519	1180	1339	141	172	148,8
	TR6	37	50	80	○	●	2651	1312	1339	144	172	170
SS7B 08	TR8	45	60	92	○	●	2737	1270	1467	192	172	231
SS7B 09	TR8	45	60	92	○	●	2865	1270	1595	192	172	235
SS7B 10	TR8	55	75	109	○	●	3073	1350	1723	192	172	254
SS7B 11	TR8	63	85	126	○	●	3341	1490	1851	192	172	284
SS7B 12	TR8	75	100	145	○	●	3569	1590	1979	192	172	307
SS7B 13	TR8	75	100	145	○	●	3697	1590	2107	192	172	311
SS7B 14	TR8	75	100	145	○	●	3825	1590	2235	192	172	315
SS7B 15	TR8	92	125	177	○	●	4193	1830	2363	192	172	365
SS7B 16	TR8	92	125	177	○	●	4321	1830	2491	192	172	369
SS7B 17	TR8	92	125	177	○	●	4449	1830	2619	192	172	373
SS7B 18	TR8	110	150	213	○	●	4807	2060	2747	192	172	427
SS7B 19	TR8	110	150	213	○	●	4935	2060	2875	192	172	431
SS7B 20	TR8	110	150	213	○	●	5063	2060	3003	192	172	435

\* Motor 6GF: 6" canned submersible motors.

Motor TR: 6"-8" rewindable submersible motors.

●	Allowed
○	Only PE2 + PA version

# SS7B

## SUBMERSIBLE PUMPS 7"

The performance curves are based on the kinematic viscosity values = 1 mm<sup>2</sup>/s and density equal to 1000 Kg/m<sup>3</sup>. Curve tolerance according to ISO 9906.

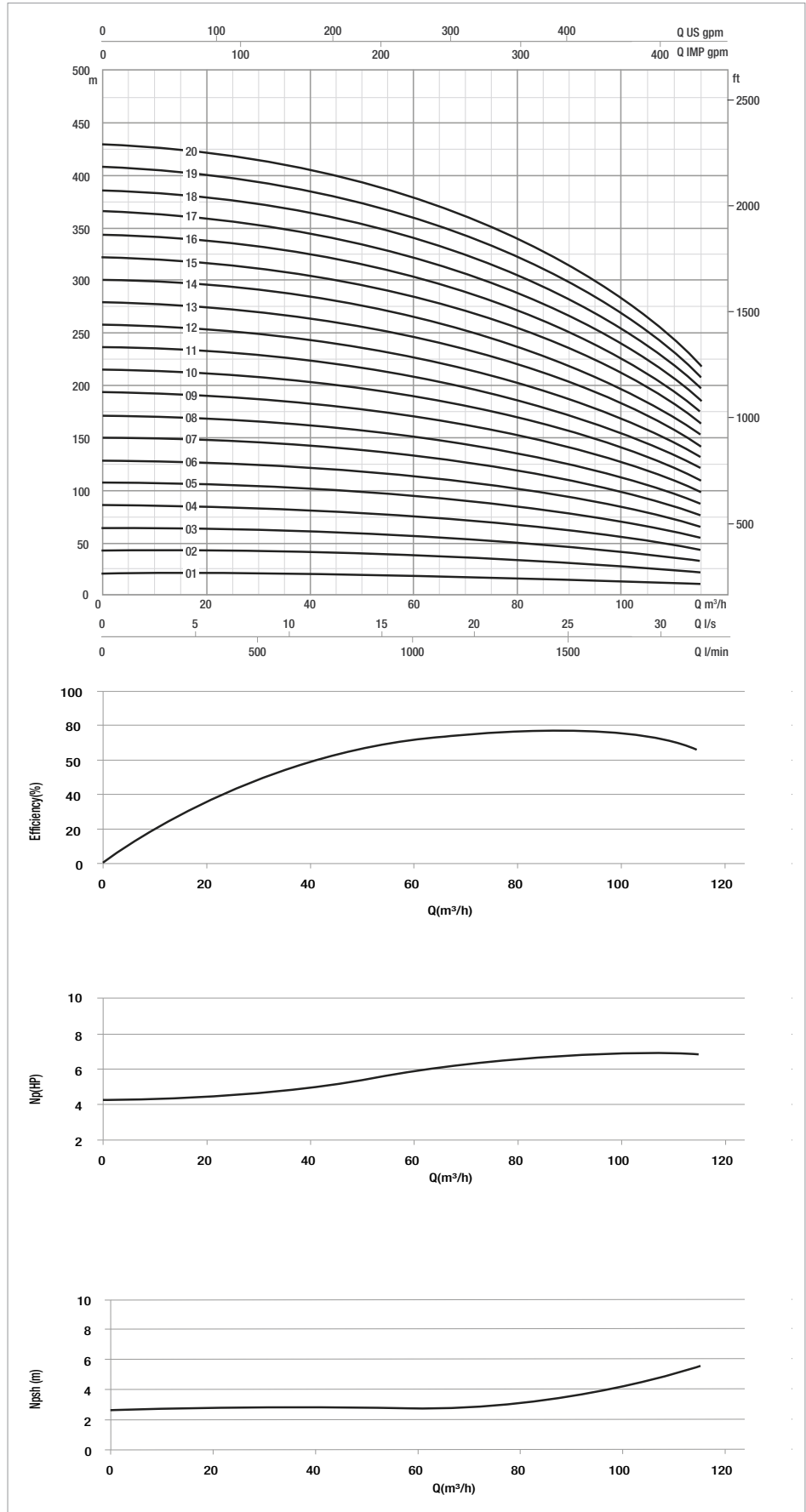
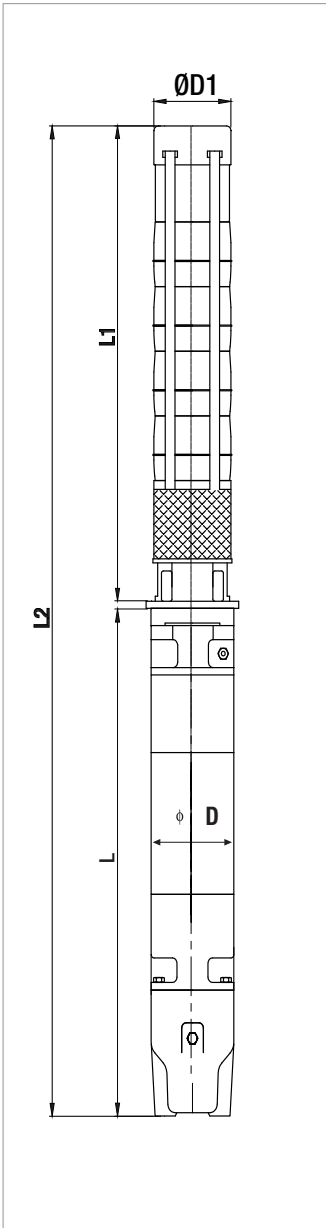

**TECHNICAL DATA**

**Performance range:** flow up to 210 m<sup>3</sup>/h and max head of 555 m

**Max. quantity of sand/silt:** 50g/m<sup>3</sup>

**Max. ambient temperature:** 30°C (50°C available on request)

**Outlet connection diameter (inside threaded):** 6"

**Nr of starts:** refer to the motor specification

**Motor Cooling flow:** refer to the motor specification

**Installation:** horizontal or vertical, refer to the motor specification

**APPLICATIONS**

Multistage mixed-flow borehole electric pumps, completely made in stainless steel (AISI 304L or AISI 316 on request), usable for wells from a minimum diameter equal to pump size or greater and capable of developing a wide range of Flows and Heads.

These pumps can be used in a wide range of lifting, distributing, and pressuring application: domestic and general water supply; sprinkler and drip irrigations systems; fire-fighting installations; lowering of groundwater level; industrial supplies as mining, hot springs, autoclaves and tanks.

These pumps are suitable both for standard water and for aggressive water applications by choosing the proper manufacturing material (AISI 304L or AISI 316) both for hydraulic part and motor.

Special version of motors with PE2+PA windings can be used on request for high-temperature water applications up to maximum 50°C.

Pumps can be installed both vertically and horizontally simply by removing the non-return valve and adding a cooling sleeve to the suction case (the only remark is to check the motor applicability to horizontal operations, refer to the motor specifications section).

**CONSTRUCTION FEATURES OF PUMP**

Mixed flow pumps with diffusers, impellers, brackets, suction case and discharge case completely made of stainless steel AISI 304 in order to provide maximum strength, durability, wear and tear resistance.

The impellers are balanced and locked to the shaft with a specially shaped collet and nut coupling, in order to guarantee ease-to-assembly feature and avoid vibration sensitive malfunctions and noise increase during rotation.

Rubber bearings that drive the shaft are water lubricated and have sand channels to make enable the sand particles leave the pump with the pumped liquid (maximum permissible sand content 50 gr/m<sup>3</sup>).

Built-in non returned valve provided in order to minimize local friction losses.

Stainless steel strainer provided in order to prevent particles over a certain size from entering the pump.

Coupling with 6", 8" or 10" motor depending on the power requested by hydraulic part:

- 6GF: 6" canned submersible motor
- TR6: 6" rewindable submersible motor
- TR8: 8" rewindable submersible motor
- TR10: 10" rewindable submersible motor

For inverter application refer to the detailed motor specification.

**ON REQUEST:**

- Pump body stainless steel AISI 316 for aggressive water application
- Impellers stainless steel AISI 316
- Motors in full stainless steel AISI 316 for aggressive water application
- Star/Delta starting version
- Special version of the motor for high temperature application
- Non-standard power coupling



### MATERIALS

N°	Part Name	Material
1	Suction Case	Stainless Steel (AISI 304L)
2	Filter	Stainless Steel (AISI 304L)
3	Suction Case Wear Ring	Bronze (ASTM B145-4A)
4	Pump Shaft	Stainless Steel (AISI 420)
5	Collet	Stainless Steel
6	Impeller Wear Ring	STAINLESS STEEL (AISI 304)
7	Impeller	Stainless Steel (AISI 304L)
8	Diffuser	Stainless Steel (AISI 304L)
9	Rubber Bearing	Rubber
10	Diffuser Wear Ring	Rubber
11	Nut for Stop Ring	Stainless Steel (AISI 304L)
12	Bearing	Rubber
13	Shaft Stopper	Bronze (ASTM B145-4A)
14	Valve	Stainless Steel (AISI 304)
15	Discharge Case	Stainless Steel (AISI 304)
16	TIE ROD	STAINLESS STEEL (AISI 304L)
17	CABLE GUARD	STAINLESS STEEL (AISI 304)
18	TIR ROD NUT	STAINLESS STEEL (AISI 303)
19	NAME PLATE	STAINLESS STEEL (AISI 304)

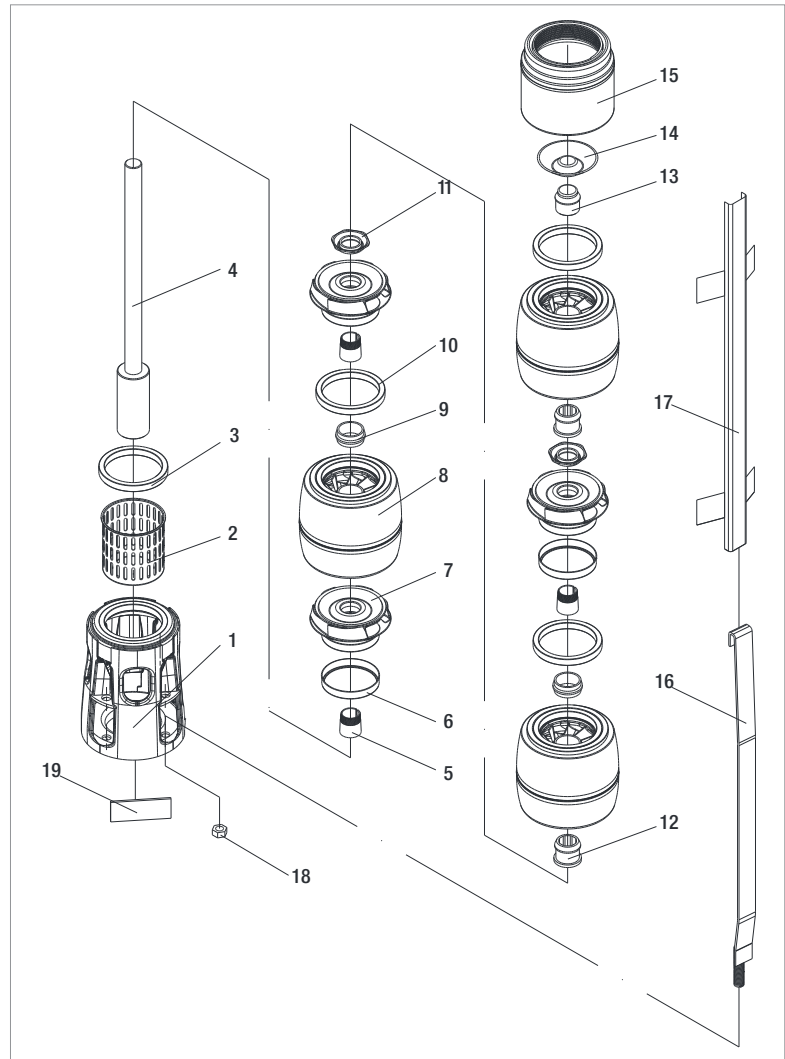

### - Designation Index: (EXAMPLE)

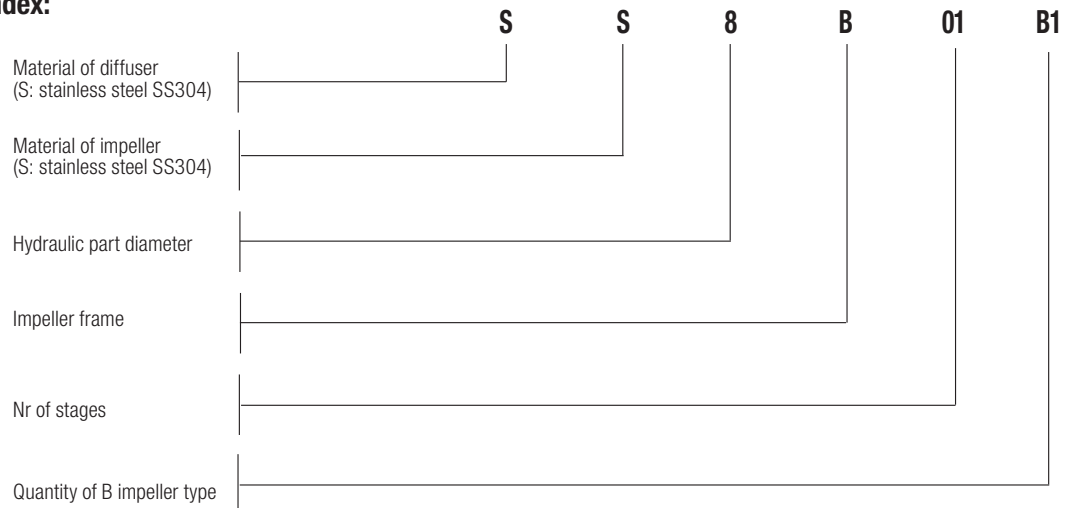

## PERFORMANCE 50 Hz - 2 POLES

MODEL	ELECTRICAL DATA		HYDRAULIC DATA											STANDARD MOTOR COUPLING
	P2 NOMINAL		Q=m <sup>3</sup> /h	0	30	70	80	90	100	110	120	130	140	
	kW	HP	Q=l/min	0	500	1166,6	1333,3	1500	1666,6	1833,3	2000	2166,6	2333,3	
SS8A 01	7,5	10	H (m)	28	26	23	22	21	20	18	16	15	12	6"
SS8A 02	15	20		56	52	46	44	42	39	36	33	29	24	6"
SS8A 03	22	30		83	78	69	66	63	59	54	49	44	37	6"
SS8A 04	30	40		111	104	91	88	83	78	73	66	58	49	6"
SS8A 05	37	50		139	129	114	110	104	98	91	82	73	61	6"
SS8A 06	45	60		167	155	137	131	125	118	109	99	87	73	8"
SS8A 07	55	75		194	181	160	153	146	137	127	115	102	86	8"
SS8A 08	63	85		222	207	183	175	167	157	145	132	116	98	8"
SS8A 09	75	100		250	233	206	197	188	176	163	148	131	110	8"
SS8A 10	75	100		278	259	229	219	208	196	182	165	145	122	8"
SS8A 11	92	125		305	285	252	241	229	216	200	181	160	135	8"
SS8A 12	92	125		333	311	274	263	250	235	218	198	174	147	8"
SS8A 13	92	125		361	337	297	285	271	255	236	214	189	159	8"
SS8A 14	110	150		389	362	320	307	292	274	254	231	203	171	8"
SS8A 15	110	150		416	388	343	329	313	294	272	247	218	184	8"
SS8A 16	132	180		444	414	366	351	333	313	290	264	232	196	10"
SS8A 17	132	180		472	440	389	373	354	333	309	280	247	208	10"
SS8A 18	132	180		500	466	412	394	375	353	327	297	262	220	10"
SS8A 19	147	200		527	492	435	416	396	372	345	313	276	233	10"
SS8A 20	147	200		555	518	457	438	417	392	363	330	291	245	10"

### ELECTRICAL DATA AND DIMENSIONS

MODEL	MOTOR *	ELECTRICAL DATA				HORIZONTAL INSTALLATION	L2 mm	L mm	L1 mm	D mm	D1 mm	TOTAL WEIGHT Kg
		P2 NOMINAL		In A	OPERATING BY INVERTER							
		kW	HP									
SS8A 01	6GF	7,5	10	18	●	●	1346	660	686	141	213	77,2
	TR6	7,5	10	18	○	●	1523	837	686	144	213	85
SS8A 02	6GF	15	20	33,4	●	●	1627	785	842	141	213	97
	TR6	15	20	32	○	●	1839	997	842	144	213	115
SS8A 03	6GF	22	30	47	●	●	1917	920	997	141	213	115,6
	TR6	22	30	49	○	●	2084	1087	997	144	213	140
SS8A 04	6GF	30	40	61,5	●	●	2203	1050	1153	141	213	137,8
	TR6	30	40	65	○	●	2365	1212	1153	144	213	161
SS8A 05	6GF	37	50	79,3	●	●	2489	1180	1309	141	213	155,8
	TR6	37	50	80	○	●	2621	1312	1309	144	213	177
SS8A 06	TR8	45	60	92	○	●	2735	1270	1465	192	213	241
SS8A 07	TR8	55	75	109	○	●	2970	1350	1620	192	213	262
SS8A 08	TR8	63	85	126	○	●	3266	1490	1776	192	213	294
SS8A 09	TR8	75	100	145	○	●	3522	1590	1932	192	213	320
SS8A 10	TR8	75	100	145	○	●	3677	1590	2087	192	213	326
SS8A 11	TR8	92	125	177	○	●	4073	1830	2243	192	213	378
SS8A 12	TR8	92	125	177	○	●	4229	1830	2399	192	213	384
SS8A 13	TR8	92	125	177	○	●	4384	1830	2554	192	213	391
SS8A 14	TR8	110	150	213	○	●	4770	2060	2710	192	213	447
SS8A 15	TR8	110	150	213	○	●	4926	2060	2866	192	213	453
SS8A 16	TR10	132	180	257	○	●	4892	1870	3022	232	213	562
SS8A 17	TR10	132	180	257	○	●	5047	1870	3177	232	213	568
SS8A 18	TR10	132	180	257	○	●	5203	1870	3333	232	213	574
SS8A 19	TR10	147	200	300	○	●	5559	2070	3489	232	213	645
SS8A 20	TR10	147	200	300	○	●	5714	2070	3644	232	213	652

\* **Motor 6GF:** 6" canned submersible motors.  
**Motor TR:** 6"-10" rewindable submersible motors.

●	Allowed
○	Only PE2 + PA version

# SS8A

## SUBMERSIBLE PUMPS 8"

The performance curves are based on the kinematic viscosity values = 1 mm<sup>2</sup>/s and density equal to 1000 Kg/m<sup>3</sup>. Curve tolerance according to ISO 9906.

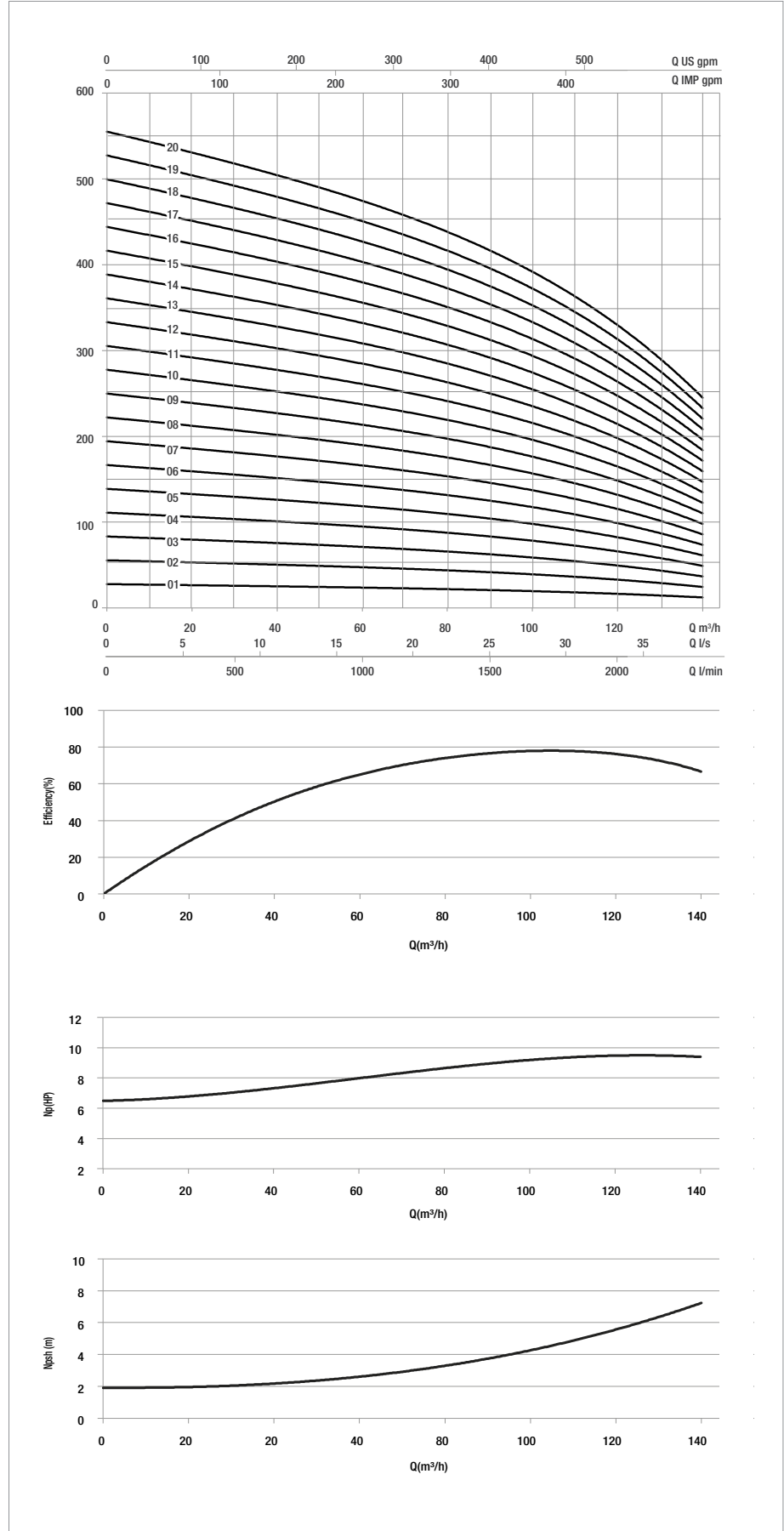
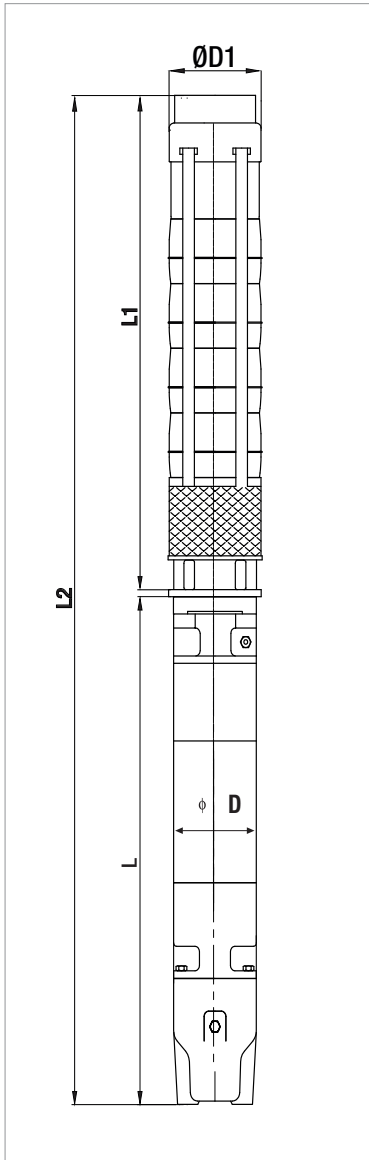



### TECHNICAL DATA

**Performance range:** flow up to 210 m<sup>3</sup>/h and max head of 555 m

**Max. quantity of sand/silt:** 50g/m<sup>3</sup>

**Max. ambient temperature:** 30°C (50°C available on request)

**Outlet connection diameter (inside threaded):** 6"

**Nr of starts:** refer to the motor specification

**Motor Cooling flow:** refer to the motor specification

**Installation:** horizontal or vertical, refer to the motor specification

### APPLICATIONS

Multistage mixed-flow borehole electric pumps, completely made in stainless steel (AISI 304L or AISI 316 on request), usable for wells from a minimum diameter equal to pump size or greater and capable of developing a wide range of Flows and Heads.

These pumps can be used in a wide range of lifting, distributing, and pressuring application: domestic and general water supply; sprinkler and drip irrigations systems; fire-fighting installations; lowering of groundwater level; industrial supplies as mining, hot springs, autoclaves and tanks.

These pumps are suitable both for standard water and for aggressive water applications by choosing the proper manufacturing material (AISI 304L or AISI 316) both for hydraulic part and motor.

Special version of motors with PE2+PA windings can be used on request for high-temperature water applications up to maximum 50°C.

Pumps can be installed both vertically and horizontally simply by removing the non-return valve and adding a cooling sleeve to the suction case (the only remark is to check the motor applicability to horizontal operations, refer to the motor specifications section).

### CONSTRUCTION FEATURES OF PUMP

Mixed flow pumps with diffusers, impellers, brackets, suction case and discharge case completely made of stainless steel AISI 304 in order to provide maximum strength, durability, wear and tear resistance.

The impellers are balanced and locked to the shaft with a specially shaped collet and nut coupling, in order to guarantee ease-to-assembly feature and avoid vibration sensitive malfunctions and noise increase during rotation.

Rubber bearings that drive the shaft are water lubricated and have sand channels to make enable the sand particles leave the pump with the pumped liquid (maximum permissible sand content 50 gr/m<sup>3</sup>).

Built-in non returned valve provided in order to minimize local friction losses.

Stainless steel strainer provided in order to prevent particles over a certain size from entering the pump.

Coupling with 6", 8" or 10" motor depending on the power requested by hydraulic part:

- 6GF: 6" canned submersible motor
- TR6: 6" rewindable submersible motor
- TR8: 8" rewindable submersible motor
- TR10: 10" rewindable submersible motor

For inverter application refer to the detailed motor specification.

### ON REQUEST:

- Pump body stainless steel AISI 316 for aggressive water application
- Impellers stainless steel AISI 316
- Motors in full stainless steel AISI 316 for aggressive water application
- Star/Delta starting version
- Special version of the motor for high temperature application
- Non-standard power coupling

### MATERIALS

N°	Part Name	Material
1	Suction Case	Stainless Steel (AISI 304L)
2	Filter	Stainless Steel (AISI 304L)
3	Suction Case Wear Ring	Bronze (ASTM B145-4A)
4	Pump Shaft	Stainless Steel (AISI 420)
5	Collet	Stainless Steel
6	Impeller Wear Ring	STAINLESS STEEL (AISI 304)
7	Impeller	Stainless Steel (AISI 304L)
8	Diffuser	Stainless Steel (AISI 304L)
9	Rubber Bearing	Rubber
10	Diffuser Wear Ring	Rubber
11	Nut for Stop Ring	Stainless Steel (AISI 304L)
12	Bearing	Rubber
13	Shaft Stopper	Bronze (ASTM B145-4A)
14	Valve	Stainless Steel (AISI 304)
15	Discharge Case	Stainless Steel (AISI 304)
16	TIE ROD	STAINLESS STEEL (AISI 304L)
17	CABLE GUARD	STAINLESS STEEL (AISI 304)
18	TIR ROD NUT	STAINLESS STEEL (AISI 303)
19	NAME PLATE	STAINLESS STEEL (AISI 304)

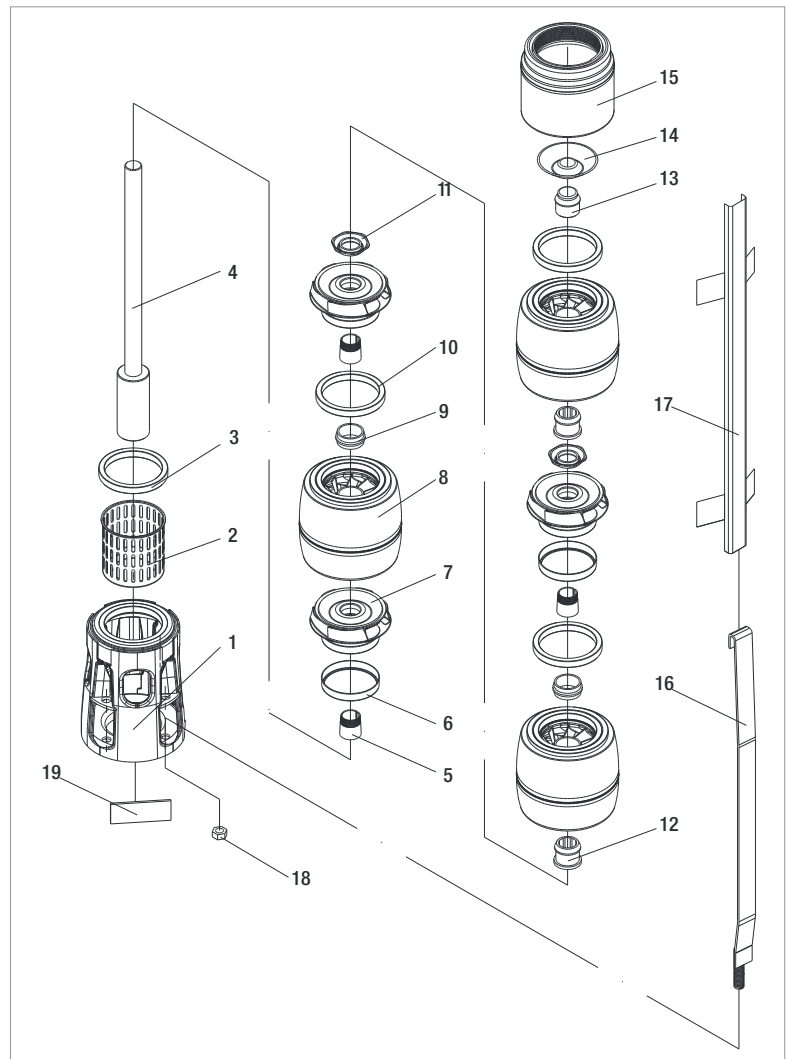

### - Designation Index: (EXAMPLE)

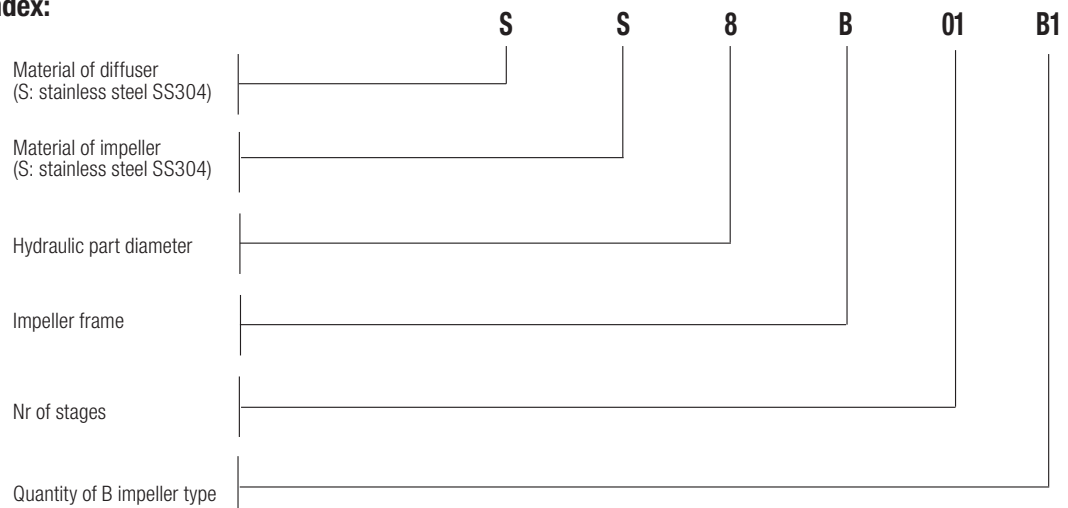

### PERFORMANCE 50 Hz - 2 POLES

MODEL	ELECTRICAL DATA		HYDRAULIC DATA											STANDARD MOTOR COUPLING
	P2 NOMINAL		Q=m <sup>3</sup> h	0	40	70	90	120	130	140	150	160	170	
	kW	HP	Q=l/min	0	666,6	1166,6	1500	2000	2166,6	2333,3	2500	2666,6	2833,3	
SS8B 01.B1	9,3	12,5	H (m)	27	25	23	22	19	18	17	16	14	12	6"
SS8B 01	11	15		33	31	28	27	24	23	21	19	17	14	6"
SS8B 02.B2	18,5	25		54	50	46	44	39	37	34	32	28	24	6"
SS8B 02	22	30		65	61	57	53	48	45	42	38	34	29	6"
SS8B 03.B3	30	40		80	75	70	66	58	55	52	47	42	35	6"
SS8B 03	37	50		98	92	85	80	71	68	63	58	51	43	6"
SS8B 04	45	60		131	122	113	107	95	90	84	77	68	58	8"
SS8B 05.B3	55	75		146	136	126	119	106	100	94	86	76	64	8"
SS8B 05	55	75		163	153	142	134	119	113	105	96	85	72	8"
SS8B 06	75	100		196	183	170	160	143	135	126	115	102	87	8"
SS8B 07	75	100		228	214	198	187	166	158	147	135	119	101	8"
SS8B 08	92	125		261	245	227	214	190	180	168	154	136	115	8"
SS8B 09	110	150		294	275	255	240	214	203	189	173	153	130	8"
SS8B 10	110	150	326	306	283	267	238	225	210	192	171	144	8"	
SS8B 11	132	180	359	336	312	294	261	248	231	211	188	159	10"	
SS8B 12	132	180	392	367	340	320	285	270	252	231	205	173	10"	
SS8B 13	147	200	424	397	368	347	309	293	273	250	222	187	10"	

### ELECTRICAL DATA AND DIMENSIONS

MODEL	MOTOR *	ELECTRICAL DATA				HORIZONTAL INSTALLATION	L2 mm	L mm	L1 mm	D mm	D1 mm	TOTAL WEIGHT Kg
		P2 NOMINAL		In A	OPERATING BY INVERTER							
		kW	HP									
SS8B 01.B1	6GF	9,3	12,5	22	●	●	1371	685	686	141	213	80,6
	TR6	9,3	12,5	21	○	●	1553	867	686	144	213	87
SS8B 01	6GF	11	15	25,5	●	●	1416	730	686	141	213	85
	TR6	11	15	25	○	●	1583	897	686	144	213	92
SS8B 02.B2	6GF	18,5	25	41	●	●	1702	860	842	141	213	106
	TR6	18,5	25	39	○	●	1899	1057	842	144	213	122
SS8B 02	6GF	22	30	47	●	●	1762	920	842	141	213	109,6
	TR6	22	30	49	○	●	1929	1087	842	144	213	134
SS8B 03.B3	6GF	30	40	61,5	●	●	2047	1050	997	141	213	131,8
	TR6	30	40	65	○	●	2209	1212	997	144	213	155
SS8B 03	6GF	37	50	79,3	●	●	2177	1180	997	141	213	143,8
	TR6	37	50	80	○	●	2309	1312	997	144	213	165
SS8B 04	TR8	45	60	92	○	●	2423	1270	1153	192	213	229
SS8B 05.B3	TR8	55	75	109	○	●	2659	1350	1309	192	213	250
SS8B 05	TR8	55	75	109	○	●	2659	1350	1309	192	213	250
SS8B 06	TR8	75	100	145	○	●	3055	1590	1465	192	213	302
SS8B 07	TR8	75	100	145	○	●	3210	1590	1620	192	213	308
SS8B 08	TR8	92	125	177	○	●	3606	1830	1776	192	213	361
SS8B 09	TR8	110	150	213	○	●	3992	2060	1932	192	213	417
SS8B 10	TR8	110	150	213	○	●	4147	2060	2087	192	213	424
SS8B 11	TR10	132	180	257	○	●	4113	1870	2243	232	213	532
SS8B 12	TR10	132	180	257	○	●	4269	1870	2399	232	213	539
SS8B 13	TR10	147	200	300	○	●	4624	2070	2554	232	213	610

\* **Motor 6GF:** 6" canned submersible motors.

**Motor TR:** 6"-10" rewindable submersible motors.

●	Allowed
○	Only PE2 + PA version



The performance curves are based on the kinematic viscosity values = 1 mm<sup>2</sup>/s and density equal to 1000 Kg/m<sup>3</sup>. Curve tolerance according to ISO 9906.

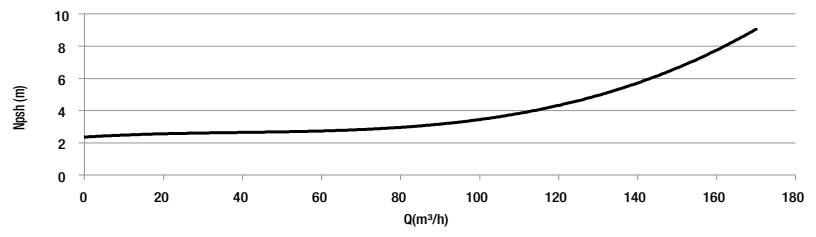
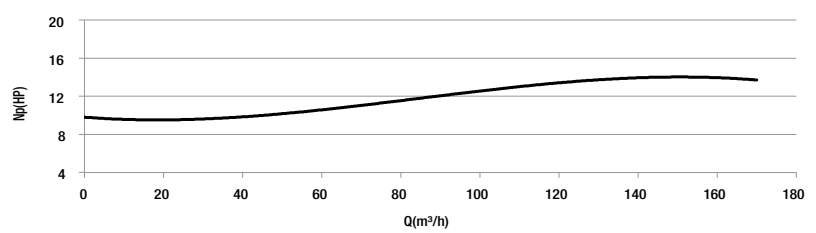
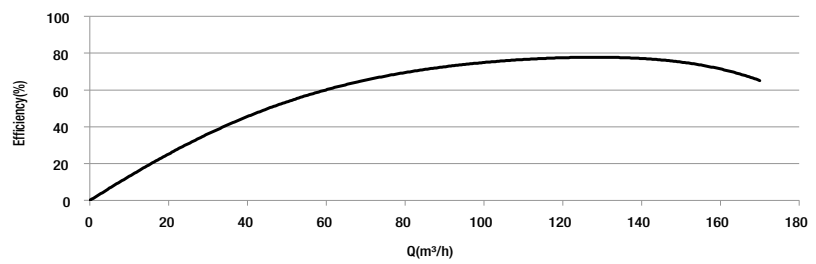
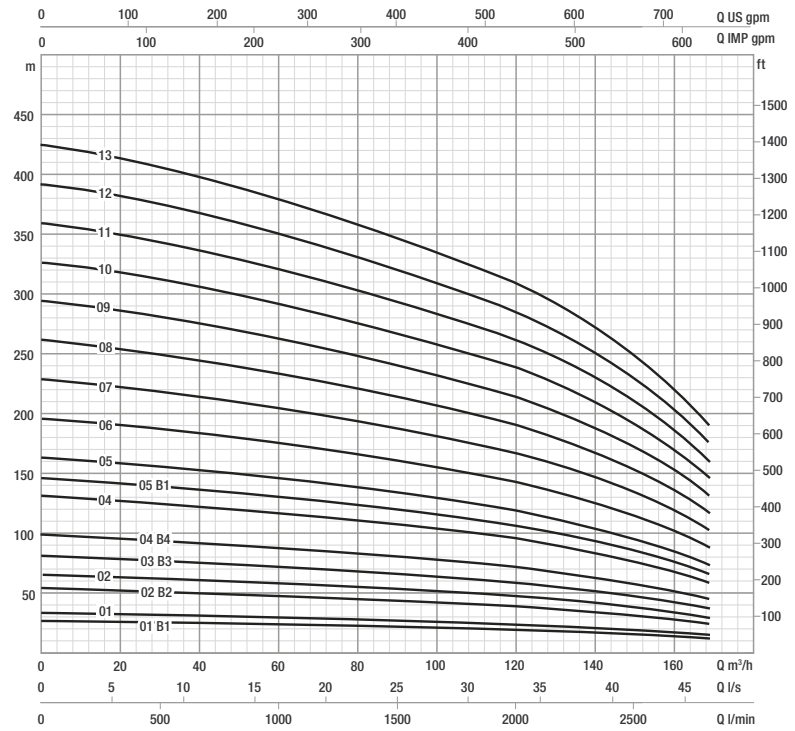
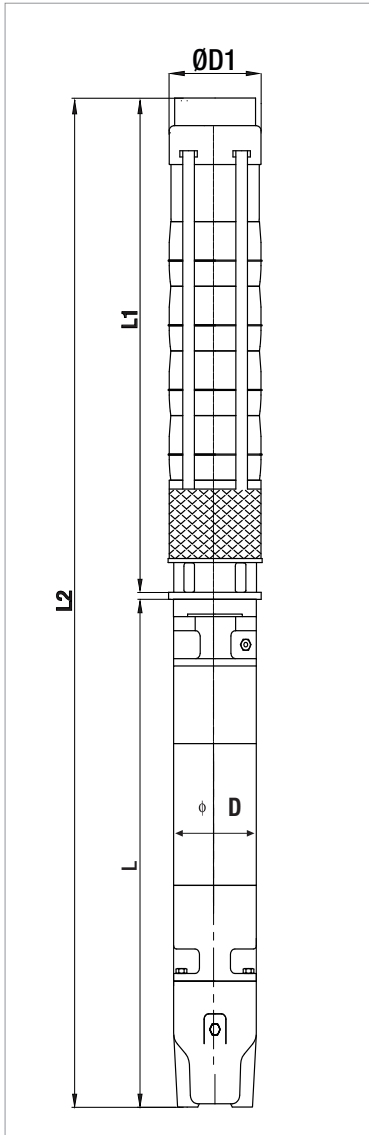

**TECHNICAL DATA**

**Performance range:** flow up to 210 m<sup>3</sup>/h and max head of 555 m

**Max. quantity of sand/silt:** 50g/m<sup>3</sup>

**Max. ambient temperature:** 30°C (50°C available on request)

**Outlet connection diameter (inside threaded):** 6"

**Nr of starts:** refer to the motor specification

**Motor Cooling flow:** refer to the motor specification

**Installation:** horizontal or vertical, refer to the motor specification

**APPLICATIONS**

Multistage mixed-flow borehole electric pumps, completely made in stainless steel (AISI 304L or AISI 316 on request), usable for wells from a minimum diameter equal to pump size or greater and capable of developing a wide range of Flows and Heads.

These pumps can be used in a wide range of lifting, distributing, and pressuring application: domestic and general water supply; sprinkler and drip irrigations systems; fire-fighting installations; lowering of groundwater level; industrial supplies as mining, hot springs, autoclaves and tanks.

These pumps are suitable both for standard water and for aggressive water applications by choosing the proper manufacturing material (AISI 304L or AISI 316) both for hydraulic part and motor.

Special version of motors with PE2+PA windings can be used on request for high-temperature water applications up to maximum 50°C.

Pumps can be installed both vertically and horizontally simply by removing the non-return valve and adding a cooling sleeve to the suction case (the only remark is to check the motor applicability to horizontal operations, refer to the motor specifications section).

**CONSTRUCTION FEATURES OF PUMP**

Mixed flow pumps with diffusers, impellers, brackets, suction case and discharge case completely made of stainless steel AISI 304 in order to provide maximum strength, durability, wear and tear resistance.

The impellers are balanced and locked to the shaft with a specially shaped collet and nut coupling, in order to guarantee ease-to-assembly feature and avoid vibration sensitive malfunctions and noise increase during rotation.

Rubber bearings that drive the shaft are water lubricated and have sand channels to make enable the sand particles leave the pump with the pumped liquid (maximum permissible sand content 50 gr/m<sup>3</sup>).

Built-in non returned valve provided in order to minimize local friction losses.

Stainless steel strainer provided in order to prevent particles over a certain size from entering the pump.

Coupling with 6", 8" or 10" motor depending on the power requested by hydraulic part:

- 6GF: 6" canned submersible motor
- TR6: 6" rewindable submersible motor
- TR8: 8" rewindable submersible motor
- TR10: 10" rewindable submersible motor

For inverter application refer to the detailed motor specification.

**ON REQUEST:**

- Pump body stainless steel AISI 316 for aggressive water application
- Impellers stainless steel AISI 316
- Motors in full stainless steel AISI 316 for aggressive water application
- Star/Delta starting version
- Special version of the motor for high temperature application
- Non-standard power coupling

### MATERIALS

N°	Part Name	Material
1	Suction Case	Stainless Steel (AISI 304L)
2	Filter	Stainless Steel (AISI 304L)
3	Suction Case Wear Ring	Bronze (ASTM B145-4A)
4	Pump Shaft	Stainless Steel (AISI 420)
5	Collet	Stainless Steel
6	Impeller Wear Ring	STAINLESS STEEL (AISI 304)
7	Impeller	Stainless Steel (AISI 304L)
8	Diffuser	Stainless Steel (AISI 304L)
9	Rubber Bearing	Rubber
10	Diffuser Wear Ring	Rubber
11	Nut for Stop Ring	Stainless Steel (AISI 304L)
12	Bearing	Rubber
13	Shaft Stopper	Bronze (ASTM B145-4A)
14	Valve	Stainless Steel (AISI 304)
15	Discharge Case	Stainless Steel (AISI 304)
16	TIE ROD	STAINLESS STEEL (AISI 304L)
17	CABLE GUARD	STAINLESS STEEL (AISI 304)
18	TIR ROD NUT	STAINLESS STEEL (AISI 303)
19	NAME PLATE	STAINLESS STEEL (AISI 304)

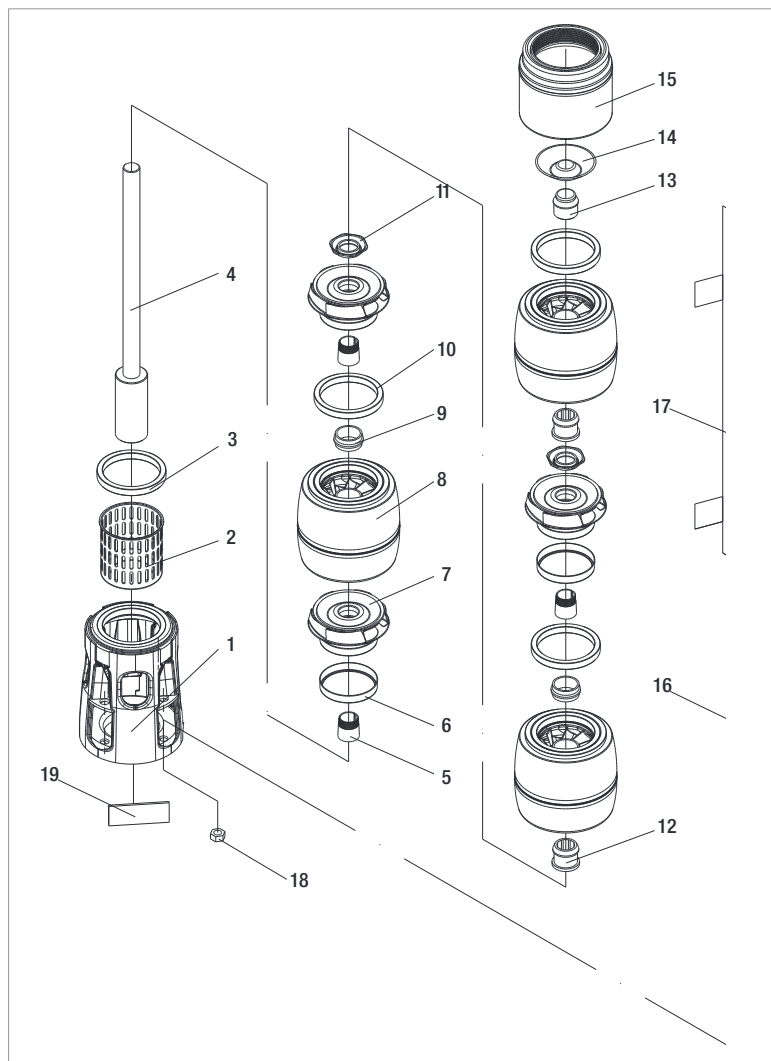

### - Designation Index: (EXAMPLE)

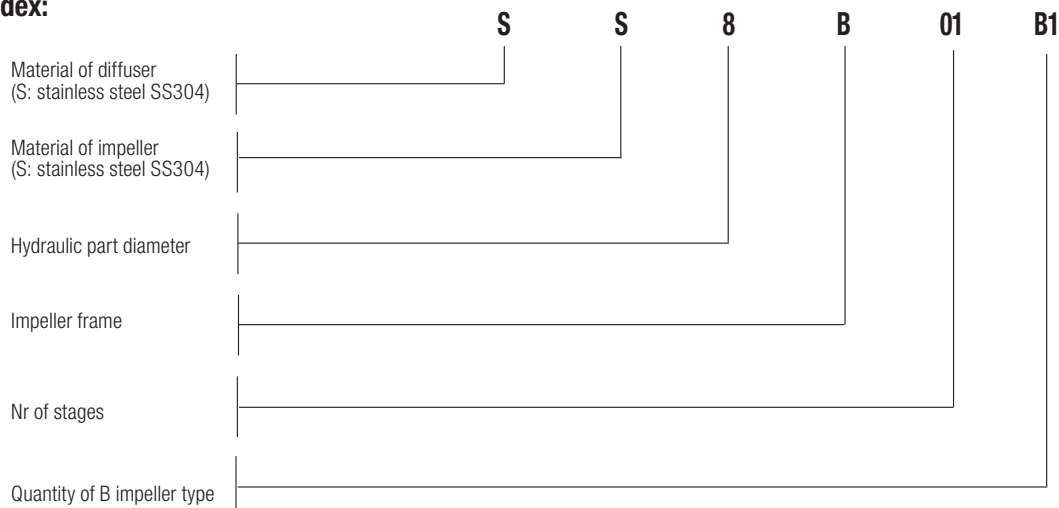

### PERFORMANCE 50 Hz - 2 POLES

MODEL	ELECTRICAL DATA		Q=m <sup>3</sup> h Q=l/min	HYDRAULIC DATA										STANDARD MOTOR COUPLING
	P2 NOMINAL			0	50	70	90	110	130	150	170	190	210	
	kW	HP		0	833,3	1166,6	1500	1833,3	2166,6	2500	2833,3	3166,6	3500	
SS8C 01.B1	9,2	12,5	H (m)	24	22	21	20	18	17	16	14	12	9	6"
SS8C 01	11	15		30	28	26	24	23	22	20	18	15	11	6"
SS8C 02.B2	18,5	25		48	44	42	39	37	34	32	28	23	17	6"
SS8C 02	22	30		60	55	52	49	46	43	40	35	29	22	6"
SS8C 03.B2	30	40		78	72	68	64	60	56	52	46	38	28	6"
SS8C 03	37	50		90	83	78	73	69	65	60	53	44	32	6"
SS8C 04	45	60		120	111	104	98	92	86	80	71	58	43	8"
SS8C 05	55	75		150	139	130	122	115	108	99	88	73	54	8"
SS8C 06.B3	63	85		162	150	141	132	124	116	107	95	79	58	8"
SS8C 06	75	100		180	166	156	147	138	129	119	106	88	65	8"
SS8C 07.B3	75	100		192	177	167	156	147	138	127	113	94	69	8"
SS8C 07	92	125		210	194	182	171	161	151	139	124	102	76	8"
SS8C 08	92	125		240	222	208	195	184	172	159	141	117	87	8"
SS8C 09	110	150		270	249	234	220	207	194	179	159	132	97	8"
SS8C 10	110	150		300	277	260	244	230	215	199	176	146	108	8"
SS8C 11	132	180		330	305	286	269	253	237	219	194	161	119	10"
SS8C 12	147	200	360	333	312	293	276	259	239	212	175	130	10"	
SS8C 13	147	200	390	360	338	318	299	280	258	229	190	141	10"	
SS8C 14	170	230	420	388	364	342	322	302	278	247	205	152	10"	
SS8C 15	190	260	450	416	390	366	345	323	298	265	219	162	10"	
SS8C 16	190	260	480	443	416	391	368	345	318	282	234	173	10"	

### ELECTRICAL DATA AND DIMENSIONS

MODEL	MOTOR *	ELECTRICAL DATA				HORIZONTAL INSTALLATION	L2 mm	L mm	L1 mm	D mm	D1 mm	TOTAL WEIGHT Kg
		P2 NOMINAL		In A	OPERATING BY INVERTER							
		kW	HP									
SS8C 01.B1	6GF	9,2	12,5	22	●	●	1371	685	686	141	226	82,6
	TR6	9,2	12,5	21	○	●	1553	867	686	144	226	89
SS8C 01	6GF	11	15	25,5	●	●	1416	730	686	141	226	87
	TR6	11	15	25	○	●	1583	897	686	144	226	94
SS8C 02.B2	6GF	18,5	25	41	●	●	1702	860	842	141	226	107
	TR6	18,5	25	39	○	●	1899	1057	842	144	226	123
SS8C 02	6GF	22	30	47	●	●	1762	920	842	141	226	110,6
	TR6	22	30	49	○	●	1929	1087	842	144	226	135
SS8C 03.B2	6GF	30	40	61,5	●	●	2047	1050	997	141	226	133,8
	TR6	30	40	65	○	●	2209	1212	997	144	226	157
SS8C 03	6GF	37	50	79,3	●	●	2177	1180	997	141	226	145,8
	TR6	37	50	80	○	●	2309	1312	997	144	226	167
SS8C 04	TR8	45	60	92	○	●	2423	1270	1153	192	226	230
SS8C 05	TR8	55	75	109	○	●	2659	1350	1309	192	226	252
SS8C 06.B3	TR8	63	85	126	○	●	2955	1490	1465	192	226	284
SS8C 06	TR8	75	100	145	○	●	3055	1590	1465	192	226	303
SS8C 07.B3	TR8	75	100	145	○	●	3210	1590	1620	192	226	310
SS8C 07	TR8	92	125	177	○	●	3450	1830	1620	192	226	356
SS8C 08	TR8	92	125	177	○	●	3606	1830	1776	192	226	362
SS8C 09	TR8	110	150	213	○	●	3992	2060	1932	192	226	419
SS8C 10	TR8	110	150	213	○	●	4147	2060	2087	192	226	425
SS8C 11	TR10	132	180	257	○	●	4113	1870	2243	232	226	534
SS8C 12	TR10	147	200	300	○	●	4469	2070	2399	232	226	605
SS8C 13	TR10	147	200	300	○	●	4624	2070	2554	232	226	612
SS8C 14	TR10	170	230	348	○	●	4930	2220	2710	232	226	658
SS8C 15	TR10	190	260	405	○	●	5266	2400	2866	232	226	704
SS8C 16	TR10	190	260	405	○	●	5422	2400	3022	232	226	711

\* Motor 6GF: 6" canned submersible motors.

Motor TR: 6"-10" rewindable submersible motors.

●	Allowed
○	Only PE2 + PA version

The performance curves are based on the kinematic viscosity values = 1 mm<sup>2</sup>/s and density equal to 1000 Kg/m<sup>3</sup>. Curve tolerance according to ISO 9906.

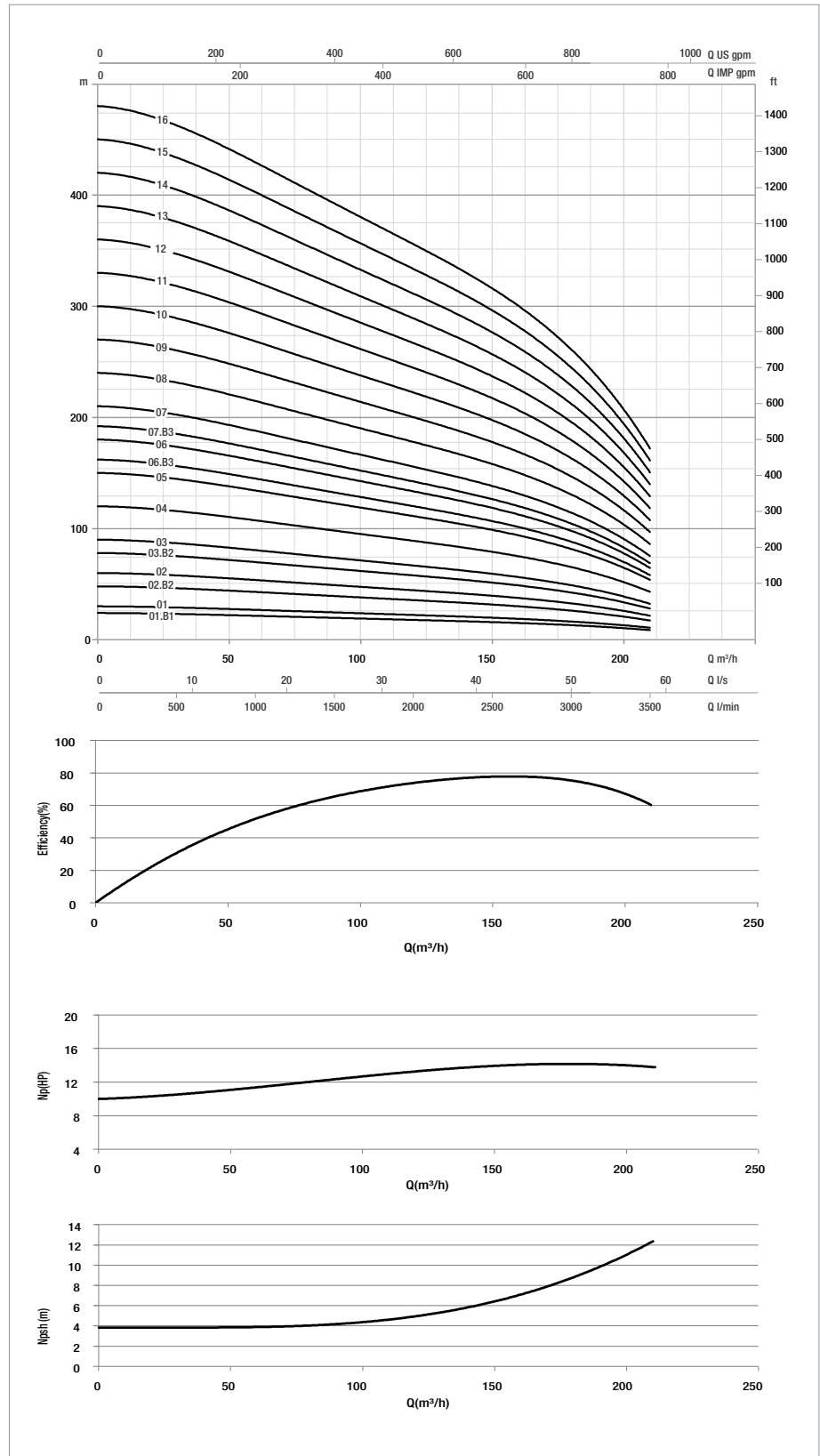
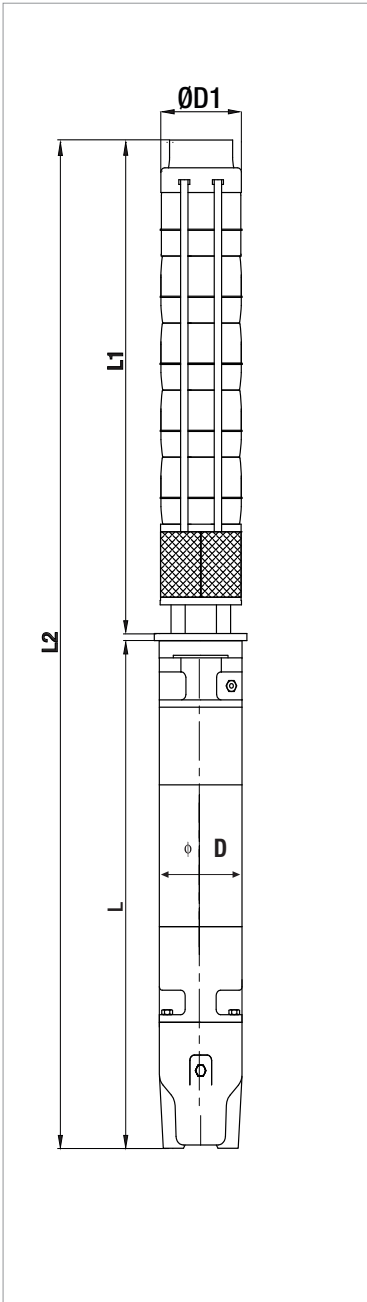



### TECHNICAL DATA

**Performance range:** flow up to 290 m<sup>3</sup>/h and max head of 385 m  
**Max. quantity of sand/silt:** 50g/m<sup>3</sup>  
**Max. ambient temperature:** 30°C (50°C available on request)  
**Outlet connection diameter (inside threaded):** 6"  
**Nr of starts:** refer to the motor specification  
**Motor Cooling flow:** refer to the motor specification  
**Installation:** horizontal or vertical, refer to the motor specification

### APPLICATIONS

Multistage mixed-flow borehole electric pumps, completely made in stainless steel (AISI 304L or AISI 316 on request), usable for wells from a minimum diameter equal to pump size or greater and capable of developing a wide range of Flows and Heads.

These pumps can be used in a wide range of lifting, distributing, and pressuring application: domestic and general water supply; sprinkler and drip irrigations systems; fire-fighting installations; lowering of groundwater level; industrial supplies as mining, hot springs, autoclaves and tanks.

These pumps are suitable both for standard water and for aggressive water applications by choosing the proper manufacturing material (AISI 304L or AISI 316) both for hydraulic part and motor.

Special version of motors with PE2+PA windings can be used on request for high-temperature water applications up to maximum 50°C.

Pumps can be installed both vertically and horizontally simply by removing the non-return valve and adding a cooling sleeve to the suction case (the only remark is to check the motor applicability to horizontal operations, refer to the motor specifications section).

### CONSTRUCTION FEATURES OF PUMP

Mixed flow pumps with diffusers, impellers, brackets, suction case and discharge case completely made of stainless steel AISI 304 in order to provide maximum strength, durability, wear and tear resistance.

The impellers are balanced and locked to the shaft with a specially shaped collet and nut coupling, in order to guarantee ease-to-assembly feature and avoid vibration sensitive malfunctions and noise increase during rotation.

Rubber bearings that drive the shaft are water lubricated and have sand channels to make enable the sand particles leave the pump with the pumped liquid (maximum permissible sand content 50 gr/m<sup>3</sup>).

Built-in non returned valve provided in order to minimize local friction losses.

Stainless steel strainer provided in order to prevent particles over a certain size from entering the pump.

Coupling with 6", 8" or 10" motor depending on the power requested by hydraulic part:

- 6GF: 6" canned submersible motor
- TR6: 6" rewindable submersible motor
- TR8: 8" rewindable submersible motor
- TR10: 10" rewindable submersible motor

For inverter application refer to the detailed motor specification.

### ON REQUEST:

- Pump body stainless steel AISI 316 for aggressive water application
- Impellers stainless steel AISI 316
- Motors in full stainless steel AISI 316 for aggressive water application
- Star/Delta starting version
- Special version of the motor for high temperature application
- Non-standard power coupling

### MATERIALS

N°	Part Name	Material
1	Suction Case	Stainless Steel (AISI 304L)
2	Filter	Stainless Steel (AISI 304L)
3	Suction Case Wear Ring	Bronze (ASTM B145-4A)
4	Pump Shaft	Stainless Steel (AISI 420)
5	Collet	Stainless Steel
6	Impeller Wear Ring	STAINLESS STEEL (AISI 304)
7	Impeller	Stainless Steel (AISI 304L)
8	Diffuser	Stainless Steel (AISI 304L)
9	Rubber Bearing	Rubber
10	Diffuser Wear Ring	Rubber
11	Nut for Stop Ring	Stainless Steel (AISI 304L)
12	Bearing	Rubber
13	Shaft Stopper	Bronze (ASTM B145-4A)
14	Valve	Stainless Steel (AISI 304)
15	Discharge Case	Stainless Steel (AISI 304)
16	TIE ROD	STAINLESS STEEL (AISI 304L)
17	CABLE GUARD	STAINLESS STEEL (AISI 304)
18	TIR ROD NUT	STAINLESS STEEL (AISI 303)
19	NAME PLATE	STAINLESS STEEL (AISI 304)

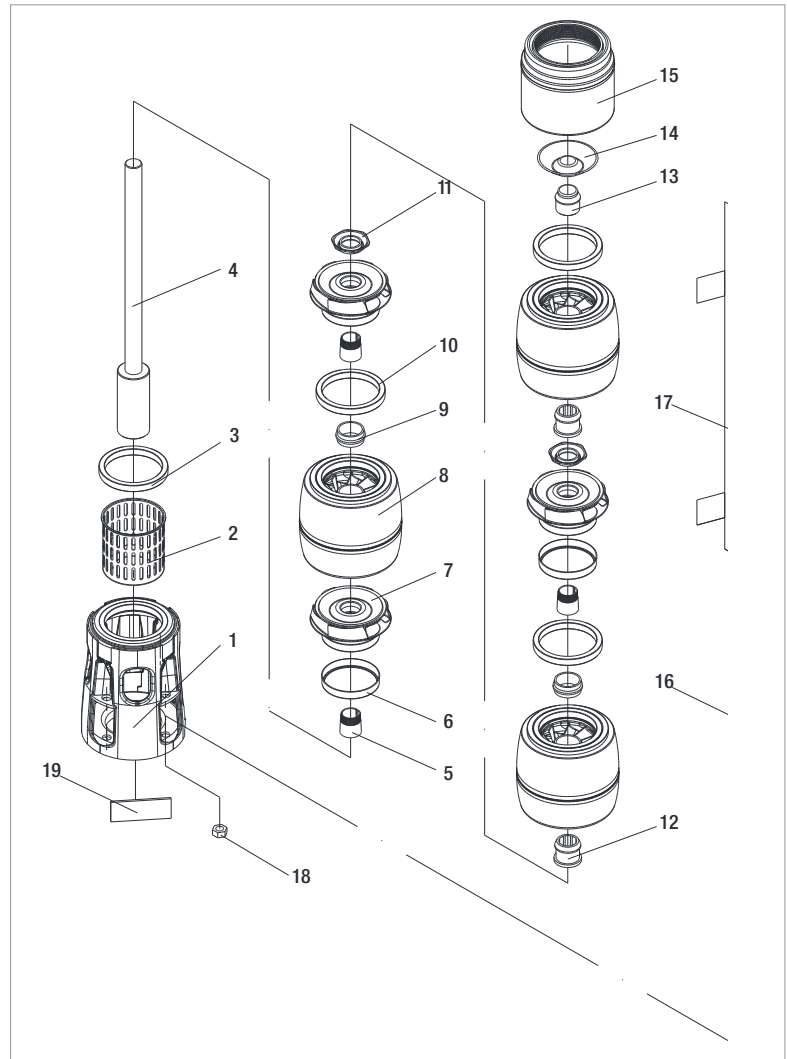

**- Designation Index:**  
(EXAMPLE)

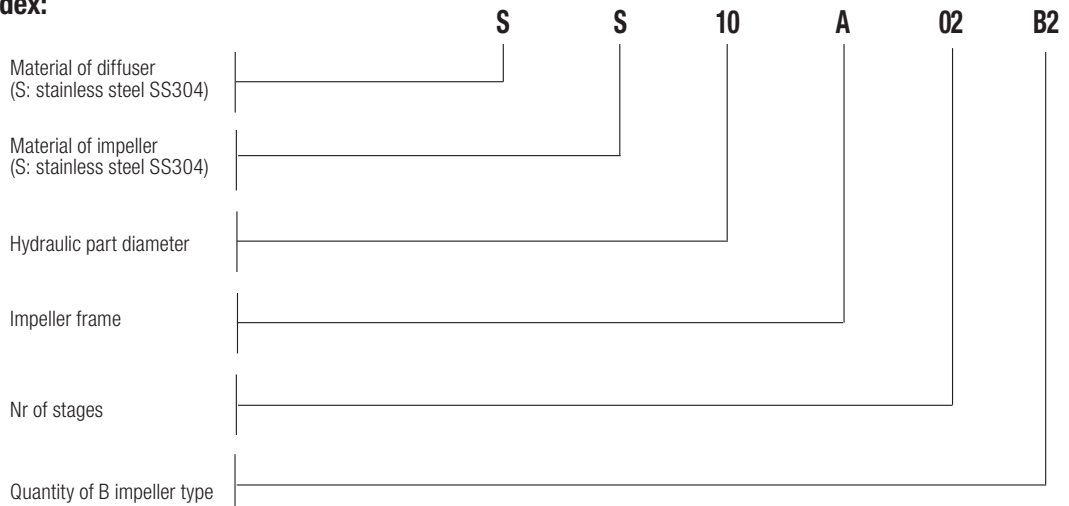



# SS10A

## SUBMERSIBLE PUMPS 10"

### PERFORMANCE 50 Hz - 2 POLES

MODEL	ELECTRICAL DATA		HYDRAULIC DATA											STANDARD MOTOR COUPLING
	P2 NOMINAL		Q=m <sup>3</sup> /h	0	50	100	140	180	200	220	240	260	290	
	kW	HP	Q=l/min	0	833,3	1666,6	2333,3	3000	3333,3	3666,6	4000	4333,3	4833,3	
SS10A 01.B1	15	20	H (mt)	29	27	25	22	20	19	18	16	15	11	6"
SS10A 01	18,5	25		39	36	33	30	27	25	24	22	19	15	6"
SS10A 02.B2	30	40		58	54	49	44	40	37	35	32	29	22	6"
SS10A 02	37	50		77	72	66	59	53	50	47	44	39	30	6"
SS10A 03.B3	45	60		87	81	74	66	59	56	53	49	44	34	8"
SS10A 03.B1	55	75		106	99	91	81	73	69	65	60	53	41	8"
SS10A 03	63	85		116	108	99	89	80	75	71	65	58	45	8"
SS10A 04.B2	75	100		135	126	115	103	93	88	82	76	68	53	8"
SS10A 04	75	100		155	145	132	119	106	100	94	87	78	60	8"
SS10A 05	92	125		194	181	165	148	133	125	118	109	97	75	8"
SS10A 06	110	150		232	217	198	178	159	151	141	131	117	91	8"
SS10A 07	132	180		271	253	231	207	186	176	165	152	136	106	10"
SS10A 08	147	200		310	289	264	237	212	201	189	174	156	121	10"
SS10A 09	170	230		349	325	298	267	239	226	212	196	175	136	10"
SS10A 10	190	260	387	362	331	296	265	251	236	218	195	151	10"	

### ELECTRICAL DATA AND DIMENSIONS

MODEL	MOTOR *	ELECTRICAL DATA				HORIZONTAL INSTALLATION	L2 mm	L mm	L1 mm	D mm	D1 mm	TOTAL WEIGHT Kg
		P2 NOMINAL		In A	OPERATING BY INVERTER							
		kW	HP									
SS10A 01.B1	6GF	15	20	33,4	●	●	1579	785	794	141	247	103
	TR6	15	20	32	○	●	1791	997	794	144	247	121
SS10A 01	6GF	18,5	25	41	●	●	1654	860	794	141	247	111
	TR6	18,5	25	39	○	●	1851	1057	794	144	247	127
SS10A 02.B2	6GF	30	40	61,5	●	●	2020	1050	970	141	247	141,8
	TR6	30	40	65	○	●	2182	1212	970	144	247	165
SS10A 02	6GF	37	50	79,3	●	●	2150	1180	970	141	247	153,8
	TR6	37	50	80	○	●	2282	1312	970	144	247	175
SS10A 03.B3	TR8	45	60	92	○	●	2417	1270	1147	192	247	243
SS10A 03.B1	TR8	55	75	109	○	●	2497	1350	1147	192	247	258
SS10A 03	TR8	63	85	126	○	●	2637	1490	1147	192	247	284
SS10A 04.B2	TR8	75	100	145	○	●	2913	1590	1323	192	247	313
SS10A 04	TR8	75	100	145	○	●	2913	1590	1323	192	247	313
SS10A 05	TR8	92	125	177	○	●	3329	1830	1499	192	247	370
SS10A 06	TR8	110	150	213	○	●	3735	2060	1675	192	247	431
SS10A 07	TR10	132	180	257	○	●	3721	1870	1851	232	247	544
SS10A 08	TR10	147	200	300	○	●	4098	2070	2028	232	247	619
SS10A 09	TR10	170	230	348	○	●	4424	2220	2204	232	247	670
SS10A 10	TR10	190	260	405	○	●	4780	2400	2380	232	247	721

\* Motor 6GF: 6" canned submersible motors.

Motor TR: 6"-10" rewindable submersible motors.

●	Allowed
○	Only PE2 + PA version

# SS10A

## SUBMERSIBLE PUMPS 10"

The performance curves are based on the kinematic viscosity values = 1 mm<sup>2</sup>/s and density equal to 1000 Kg/m<sup>3</sup>. Curve tolerance according to ISO 9906.

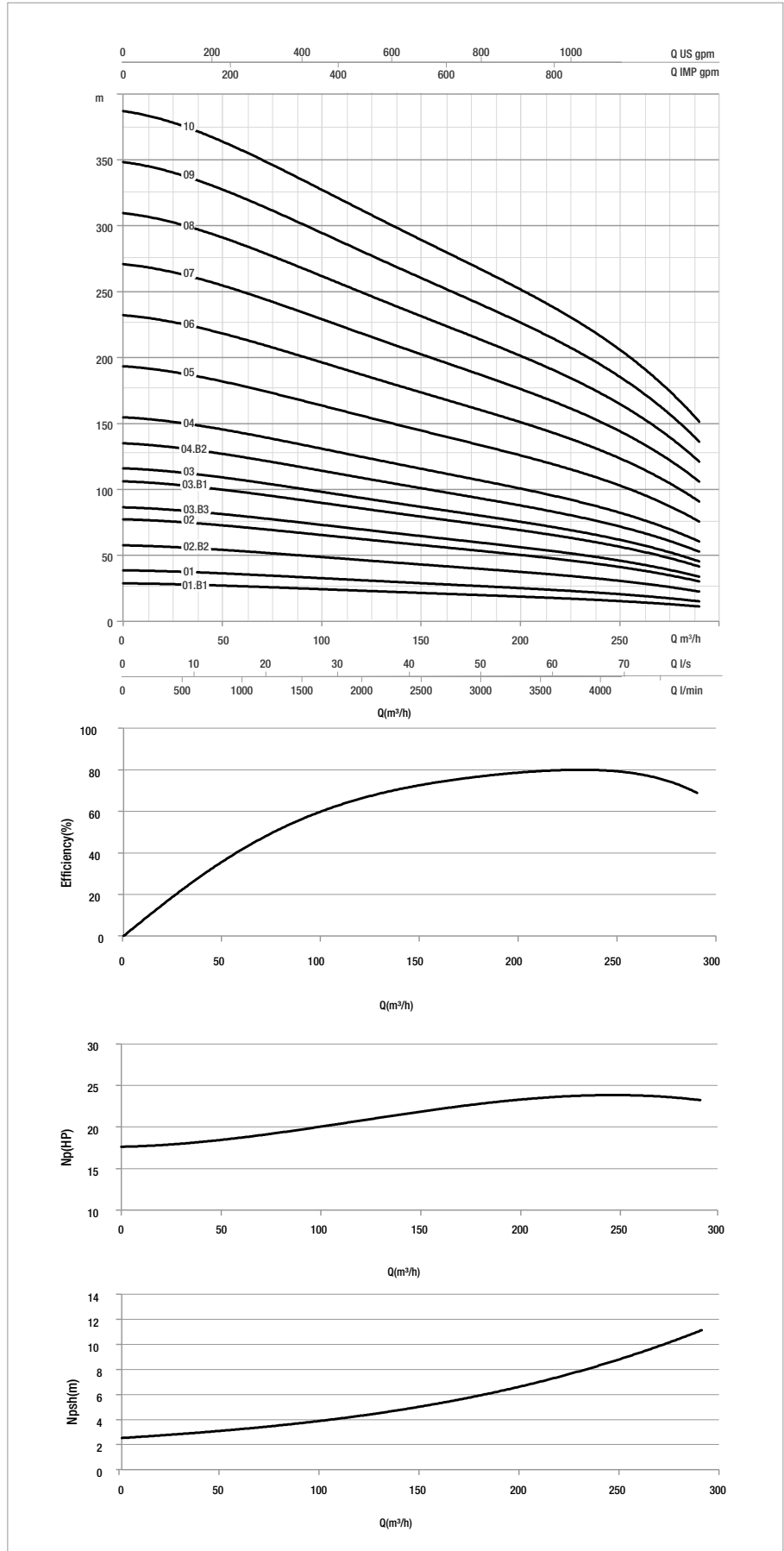
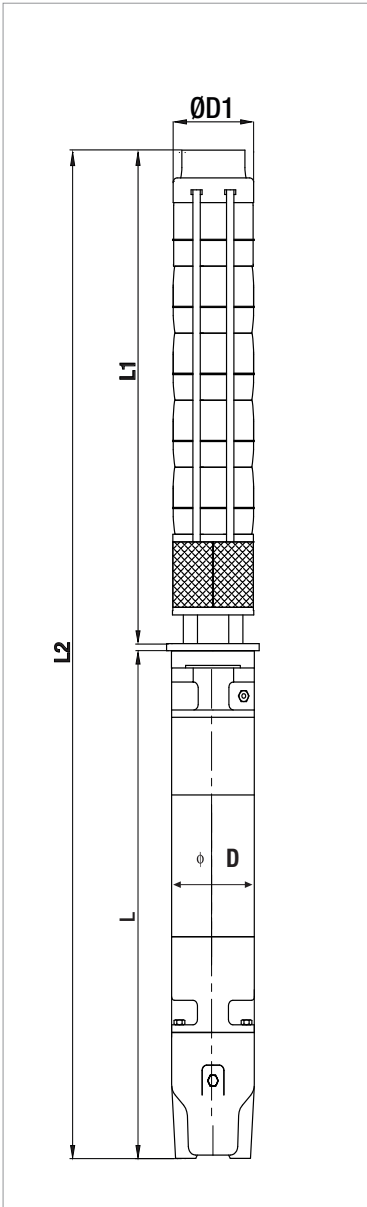

# 6GF - 6GX

## SUBMERSIBLE MOTOR 6"



### Technical Specifications

**Flange:** NEMA 6"  
**insulation class:** F  
**Degree of protection:** IP68  
**Cooling flow** min. 0.3 m/s 35° C  
**Voltage tolerance:** + 6% / -10%  
**Max starts:** 25/h  
**Max operating depth:** 300 m  
**Horizontal operation:** 5,5 HP - 50 HP

### GENERAL DATA

6" Asynchronous two-poles submersible motor, made in AISI 304 stainless steel and cast iron with paint coating for parts in contact with water. Cooling and lubrication of the thrust bearing assembly and carbon bushes is provided by a mixture of water and glycol. Squirrel-cage rotor mounted on Kingsbury self-centring thrust bearing. Stator housed in an airtight stainless steel casing (canned-type). Removable cable connector to allow fast and easy maintenance. The cable is certified ACS, WRAS and KTW. Motor suitable for use with variable frequency drive (30 Hz-50/60 Hz). The motor is available in three-phase version with DOL or STAR-DELTA starting type. Overload protection must be provided by user. 6GX version made entirely in stainless steel AISI 316 with mechanical seal in silicon carbide. The motor can be equipped also with a PT100 temperature sensor.

### COMPONENTS



Canned stator with external shell made in AISI 304L stainless steel and flangs with an anti-corrosion treatment. The stator has 24 slots for better elasticity and regularity of operation. Class H double insulated copper wire.



Kingsbury type thrust bearing unit consisting of tilting pads made of highly-resistant stainless steel and machined by Tesla using the spherical lapping process.  
From 5,5 HP to 30 HP: 16000N  
From 40 HP to 50 HP: 27000N



Shafts with end part made of stainless steel "Duplex". Squirrel-cage rotor made in copper for all motor powers.

# 6GF - 6GX

## SUBMERSIBLE MOTOR 6"

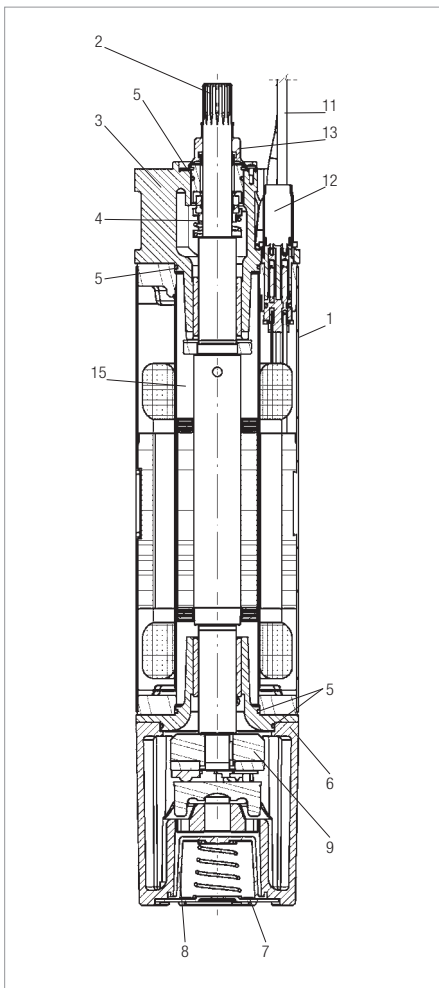

### MATERIALS

N°	COMPONENTS	VERSION 6GF	VERSION 6GX
1	INT. AND EXTERNAL SLEEVE	AISI 304L	AISI 316 TI
2	SHAFT END	DUPLEX	DUPLEX
3	UPPER BRACKET	PAINTED CAST IRON	AISI 316
4	MECHANICAL SEAL	CERAMIC - CARBON	SIC / SIC
5	GASKET	NBR	VITON
6	LOWER BRACKET	PAINTED CAST IRON	AISI 316
7	LOWER COVER	AISI 304	AISI 316
8	DIAPHRAGM	EPDM	EPDM
9	THRUST BEARING	STAINLESS STEEL - GRAPHITE	STAINLESS STEEL - GRAPHITE
10	VALVE	BRASS	AISI 316
11	CABLE	EPDM	EPDM
12	CONNECTING PLUG	AISI 316	AISI 316
13	SAND GUARD (FIXED-REMOVABLE)	NBR	EPDM
14	BOLTS & SCREWS	AISI 304	AISI 316
15	COOLING LIQUID	ANTIFREEZE + WATER	ANTIFREEZE + WATER

### DIMENSION - SINGLE PHASE MOTORS

TYPE	P2		LENGTH mm	WEIGHT 6GF Kg	WEIGHT 6GX Kg	AXIAL THRUST N
	hp	kW				
50 Hz	5	3,7	660	45,2t	44	16000
	7,5	5,5	730	51,6	49,8	16000
	10	7,5	785	57,6	56,2	16000
	15	11	860	65,6	63,8	16000

### DIMENSION - THREE PHASE MOTORS

TYPE	P2		LENGTH mm	WEIGHT 6GF Kg	WEIGHT 6GX Kg	AXIAL THRUST N
	hp	kW				
50 Hz	5,5	4	600	39,4	38	16000
	7,5	5,5	631	42,6	41	16000
	10	7,5	660	45,2	44	16000
	12,5	9,3	685	48,6	47	16000
	15	11	730	53	51,8	16000
	20	15	785	59	57,6	16000
	25	18,5	860	67	65,2	16000
	30	22	920	70,6	71,2	16000
	40	30	1050	86,8	85,2	27000
	50	37	1180	98,8	97,6	27000

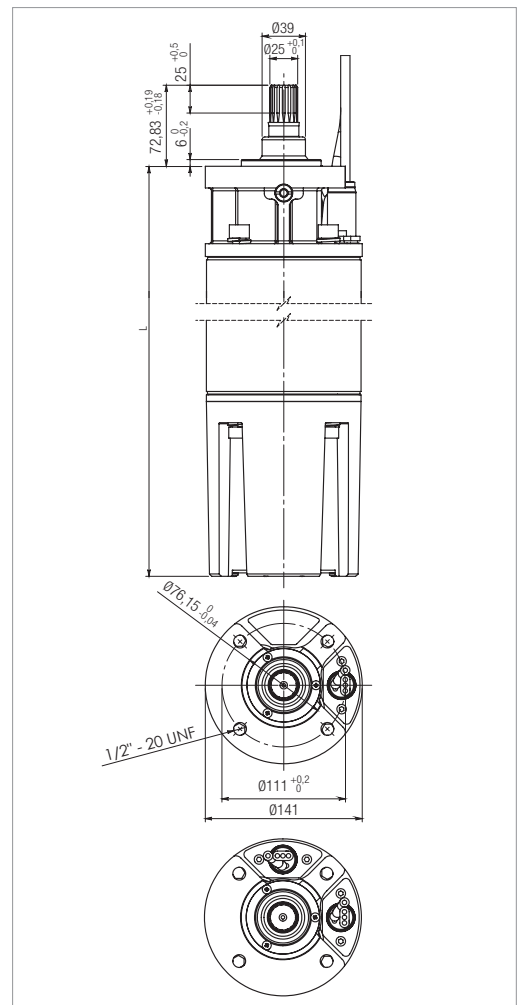

SUBMERSIBLE MOTORS

### ELECTRICAL DATA - THREE PHASE MOTORS

MODEL	P2		VOLTAGE 50Hz	In A	Is/In	P1 W	N min <sup>-1</sup>	Cos φ	η %	STARTING	CABLE	
	hp	kW									Ø mm <sup>2</sup>	LC m
6GF/6GX - 4kW - 230V - T	5,5	4	230	18,3	4,0	5290	2845	0,75	76	Δ	4x4	4
6GF/6GX - 4kW - 400V - T			400	10,6	4,1	5290	2845	0,75	76	Y	4x4	4
6GF/6GX - 4kW - 415V - T			415	11	4,3	5500	2860	0,7	73	Y	4x4	4
6GF/6GX - 5,5kW - 230V - T	7,5	5,5	230	24,3	4,6	7270	2845	0,75	76	Δ	4x4	4
6GF/6GX - 5,5kW - 400V - T			400	14	4,6	7270	2845	0,75	76	Y	4x4	4
6GF/6GX - 5,5kW - 415V - T			415	14,6	4,8	7330	2860	0,71	73	Y	4x4	4
6GF/6GX - 7,5kW - 230V - T	10	7,5	230	31	4,1	9550	2840	0,78	78	Δ	4x4	4
6GF/6GX - 7,5kW - 400V - T			400	18	4,1	9550	2840	0,78	78	Y	4x4	4
6GF/6GX - 7,5kW - 415V - T			415	18,3	4,4	9700	2850	0,73	77	Y	4x4	4
6GF/6GX - 9,2kW - 230V - T	12,5	9,2	230	37,3	3,9	11460	2840	0,8	80	Δ	4x4	4
6GF/6GX - 9,2kW - 400V - T			400	22	3,9	11460	2840	0,8	80	Y	4x4	4
6GF/6GX - 9,2kW - 415V - T			415	22,8	4,2	11600	2850	0,79	79	Y	4x4	4
6GF/6GS/6GX - 11kW - 230V - T	15	11	230	44,2	4,4	13860	2840	0,82	79	Δ	4x6	4
6GF/6GX - 11kW - 400V - T			400	25,5	4,4	13860	2840	0,82	79	Y	4x4	4
6GF/6GX - 11kW - 415V - T			415	26	4,8	14100	2845	0,79	78	Y	4x4	4
6GF/6GX - 15kW - 230V - T	20	15	230	56	4,8	17960	2840	0,8	83	Δ	4x6	4
6GF/6GX - 15kW - 400V - T			400	33,4	4,8	17960	2840	0,8	83	Y	4x4	4
6GF/6GX - 15kW - 415V - T			415	34,2	5,0	18200	2850	0,76	82	Y	4x4	4
6GF/6GX - 18,5kW - 230V - T	25	18,5	230	71	5,2	22300	2845	0,8	83	Δ	4x8	4
6GF/6GX - 18,5kW - 400V - T			400	41	5,2	22300	2845	0,8	83	Y	4x6	4
6GF/6GX - 18,5kW - 415V - T			415	42	5,5	22450	2855	0,73	82	Y	4x4	4
6GF/6GX - 22kW - 230V - T	30	22	230	81,4	5,1	26500	2825	0,84	83	Δ	4x8	4
6GF/6GX - 22kW - 400V - T			400	47	5,1	26500	2825	0,84	83	Y	4x6	4
6GF/6GX - 22kW - 415V - T			415	47,5	5,4	26850	2835	0,80	82	Y	4x4	4
6GF/6GX - 30kW - 400V - T	40	30	400	61,5	4,6	35130	2830	0,85	85	Y	4x8	4
6GF/6GX - 30kW - 415V - T			415	63,5	4,7	35600	2840	0,8	84	Y	4x8	4
6GF/6GX - 37kW - 400V - T	50	37	400	79,3	3,7	44200	2830	0,84	82	Y	4x8	4
6GF/6GX - 37kW - 415V - T			415	80	3,9	44200	2840	0,80	81	Y	4x8	4

**P2:** Rated Output  
**V:** Rated Voltage  
**In:** Rated Current  
**Is/In:** Locked rotor current/Rated current  
**P1:** Power Consumption

**N:** Revolution per minute- R.p.m  
**Cos φ:** Power Factor  
**η:** Efficiency  
**Ø:** Cable Section  
**LC:** Cable Length



## TECHNICAL SPECIFICATIONS

**Flange:** NEMA 6"  
**Degree of protection:** IP68  
**Cooling flow:** 0.5 m/s  
**Voltage tolerance:** + 6% / -10%  
**Max starts:** 15/h  
**Max operating depth :** 300 m  
**Max operating pressure:** 60 bar  
**Horizontal operation:** 7,5 HP - 50 HP

## GENERAL DATA

6" Asynchronous two-poles submersible motor, rewindable type, made in AISI 304 stainless steel and cast iron with paint coating (standard version). Cooling and lubrication of the thrust bearing assembly and carbon bushes is provided by a mixture of water and glycol. Squirrel-cage rotor mounted on Mitchell self-centring thrust bearing. The motor is available also in full stainless steel AISI 316 version or AISI 904 version. On request it's available also a version suitable for use with variable frequency drive (30 Hz-50/60 Hz). The motor is equipped with 5 meters three-core cable directly connected with the windings and a ground cable, and it's available with DOL or STAR-DELTA starting type. The cable is certified ACS and WRAS and KTW. Overload protection must be provided by user. On request PT100 and PTC temperature sensors are available.

## COMPONENTS



The stator is rewindable type and it's inserted in an AISI 304 stainless steel outer shell (on request AISI 316 or AISI 904). In the standard version the windings are made in copper insulated by PVC. On request it's available the PE2+PA windings for special applications such as the use with a variable frequency drive.

Mitchell type thrust bearing unit consisting of tilting pads in stainless steel and graphite disc.  
 From 5 HP to 20 HP: 15000 N  
 From 25 HP to 50 HP: 27500 N  
 Upthrust: 6000 N

Shafts made of stainless steel with end part according to 6" NEMA norms. Squirrel-cage rotor made in aluminium for motor powers up to 20 HP, in copper for motor powers above 25 HP. In the standard version the motors are equipped with a ceramic/carbon mechanical seal and are equipped also with a lip seal (granting the IP 68 insulation). On request it's available the silicon carbide (SiC/SiC) mechanical seal.

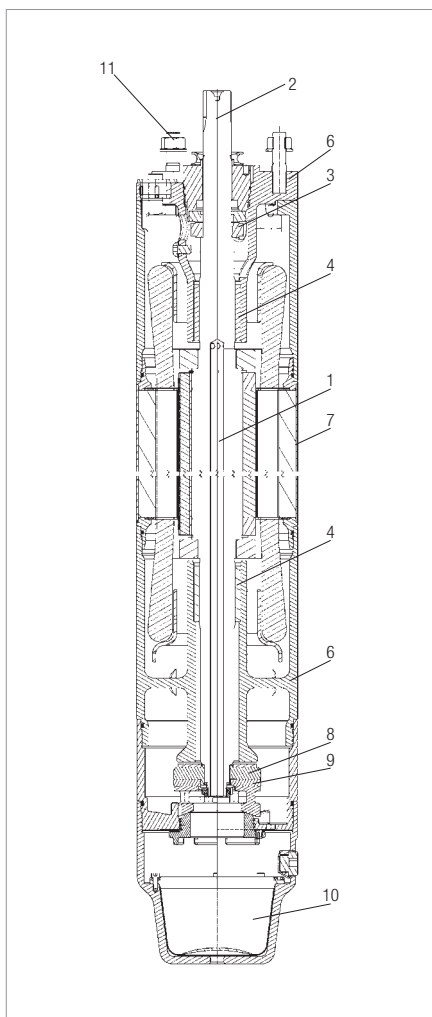

### MATERIALS

N°	COMPONENTS	STD VERSION	316 SS VERSION	904 SS VERSION
1	SHAFT	STAINLESS STEEL	STAINLESS STEEL	STAINLESS STEEL
2	SHAFT END	STAINLESS STEEL	STAINLESS STEEL	STAINLESS STEEL
3	MECHANICAL SEAL	CERAMIC-CARBON	SIC/SIC	SIC / SIC
4	BEARING RING	GRAPHITE	GRAPHITE	GRAPHITE
5	CABLE	EPDM	EPDM	EPDM
6	STRUCTURAL PARTS	CAST IRON	STAINLESS STEEL	STAINLESS STEEL
7	EXTERNAL SLEEVE	STAINLESS STEEL	STAINLESS STEEL	STAINLESS STEEL
8	THRUST BEARING ROTATING	GRAPHITE	GRAPHITE	Graphite
9	THRUST BEARING STATIONARY	STAINLESS STEEL	STAINLESS STEEL	STAINLESS STEEL
10	DIAPHRAGM	EPDM	EPDM	EPDM
11	BOLTS & SCREWS	STAINLESS STEEL	STAINLESS STEEL	STAINLESS STEEL

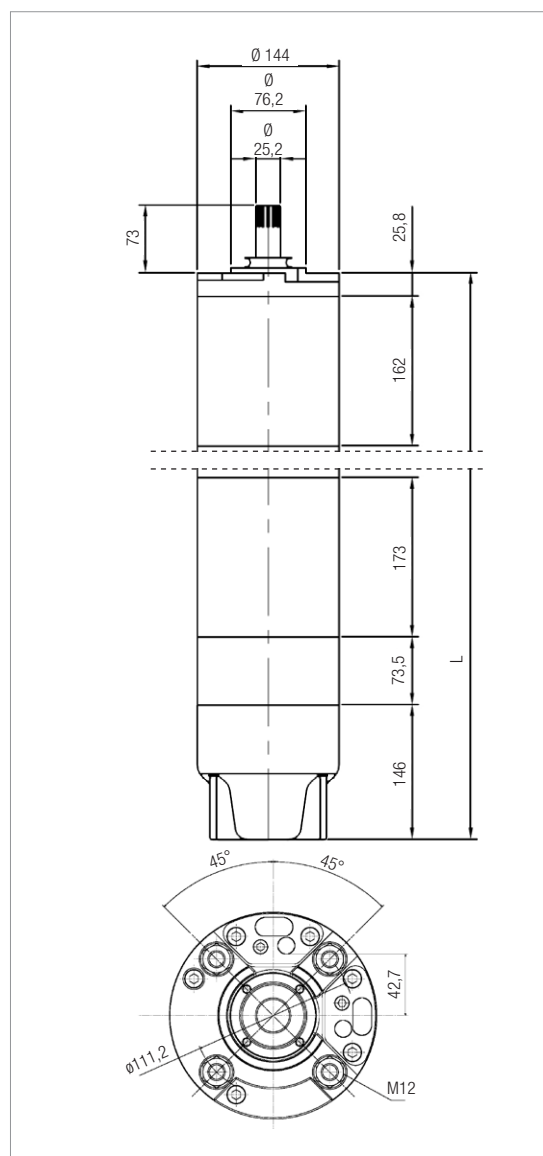

### DIMENSION - THREE PHASE MOTORS

TYPE	P2		LENGTH mm	WEIGHT Kg	AXIAL THRUST N
	hp	kW			
50 Hz	7,5	5,5	807	50	15000
	10	7,5	837	53	15000
	12,5	9,2	867	55	15000
	15	11	897	60	15000
	17,5	13	927	65	15000
	20	15	997	77	15000
	25	18,5	1057	83	27500
	30	22	1087	95	27500
	35	26	1157	105	27500
	40	30	1212	110	27500
	50	37	1312	120	27500



### DERATING

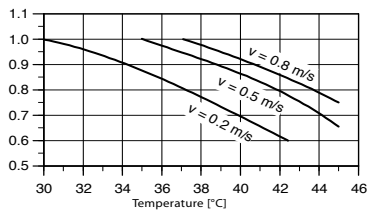

PVC Windings da 5.5 a 30 kW

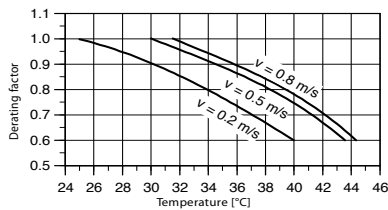

PVC Windings 37 kW

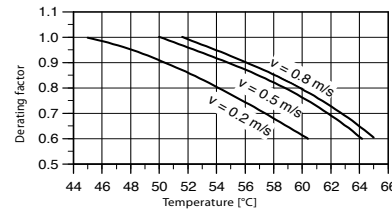

PE2/PA Windings da 5.5 a 37 kW

### ELECTRICAL DATA - THREE PHASE MOTORS

MODEL	P2		VOLTAGE 50Hz	In A	Is/In	P1 W	N min <sup>-1</sup>	Cos φ	η %	CABLE	
	hp	kW								Ø mm <sup>2</sup>	LC m
TR6 - 5,5kW - 400V - T	7,5	5,5	400	13	3,7	7432	2870	0,81	74	3x6 + 1x6	5
TR6 - 7,5kW - 400V - T	10	7,5	400	18	3,7	9740	2870	0,80	77	3x6 + 1x6	5
TR6 - 9,2kW - 400V - T	12,5	9,2	400	21	3,6	11948	2860	0,81	77	3x6 + 1x6	5
TR6 - 11kW - 400V - T	15	11	400	25	3,7	14103	2860	0,82	78	3x6 + 1x6	5
TR6 - 13kW - 400V - T	17,5	13	400	29	3,8	16250	2870	0,82	80	3x6 + 1x6	5
TR6 - 15kW - 400V - T	20	15	400	32	3,8	18519	2860	0,83	81	3x6 + 1x6	5
TR6 - 18,5kW - 400V - T	25	18,5	400	39	5,3	22024	2890	0,83	84	3x6 + 1x6	5
TR6 - 22kW - 400V - T	30	22	400	49	5,5	26506	2880	0,79	83	3x6 + 1x6	5
TR6 - 26kW - 400V - T	35	26	400	58	5,7	31325	2880	0,79	83	3x10 + 1 x10	5
TR6 - 30kW - 400V - T	40	30	400	65	5,0	35714	2870	0,81	84	3x10 + 1 x10	8
TR6 - 37kW - 400V - T	50	37	400	80	5,0	44578	2860	0,81	83	3x10 + 1 x10	8
TR6 - 45kW - 400V - T	60	45	400	93,1	5,1	54127	2825	0,85	83	3x10 + 1 x10	8

**P2:** Rated Output  
**V:** Rated Voltage  
**In:** Rated Current  
**Is/In:** Locked rotor current/Rated current  
**P1:** Power Consumption

**N:** Revolution per minute- R.p.m  
**Cos φ:** Power Factor  
**η:** Efficiency  
**Ø:** Cable Section  
**LC:** Cable Length



## TECHNICAL SPECIFICATIONS

**Flange:** NEMA 8"  
**Degree of protection:** IP58 (IP68 su richiesta)  
**Cooling flow:** 0.5 m/s  
**Voltage tolerance:** + 6% / -10%  
**Max starts:** 10/h  
**Max operating depth:** 300 m  
**Max operating pressure:** 60 bar  
**Horizontal operation:** 30 HP - 125 HP

## GENERAL DATA

8" Asynchronous two-poles or four-poles submersible motor, rewindable type, with external shell made in AISI 316 stainless steel and supports in cast iron with paint coating (standard version). Cooling and lubrication of the thrust bearing assembly and carbon bushes is provided by a mixture of water and glycol. Squirrel-cage rotor mounted on Mitchell self-centring thrust bearing. The motor is available also in full stainless steel AISI 316 version or AISI 904 version. On request it's available also a version suitable for use with variable frequency drive (30 Hz-50/60 Hz). The motor is equipped with 5 meters three-core cable directly connected with the windings and it's available with DOL or STAR-DELTA starting type. The cable is certified ACS and WRAS and KTW. Overload protection must be provided by user. On request PT100 and PTC temperature sensors.

## COMPONENTS



The stator is rewindable type and it's inserted in an AISI 316 stainless steel outer shell (on request AISI 904). In the standard version the windings are made in copper insulated by PVC. On request it's available the PE2+PA windings for special applications such as the use with a variable frequency drive.

Mitchell type thrust bearing unit consisting of tilting pads in graphite and ceramic disc.  
 From 30 HP to 150 HP: 60000 N  
 Upthrust: 12500 N

Shafts made of stainless steel with end part according to 8" NEMA norms. Squirrel-cage rotor made in copper. In the standard version the motor is equipped with a ceramic/carbon mechanical seal. On request it's available the silicon carbide (SiC/SiC) mechanical seal. On request the motor can be equipped also with a lip seal (granting the IP 68 insulation).

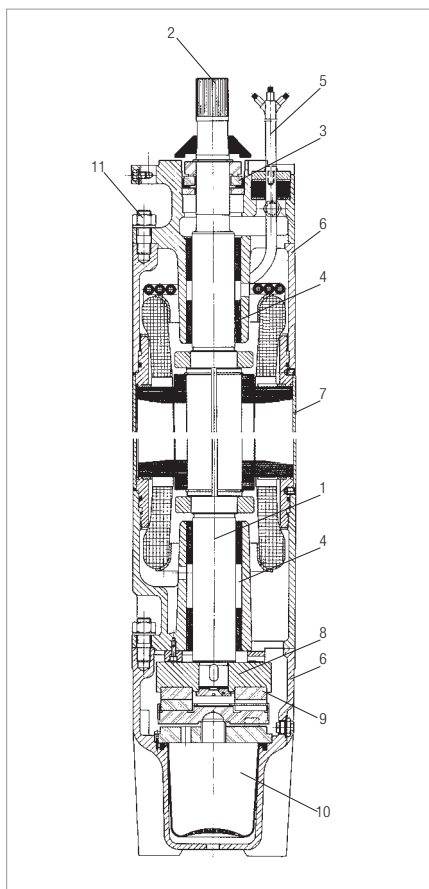

### MATERIALS

N°	COMPONENTS	STD VERSION	316 SS VERSION	904 SS VERSION
1	SHAFT	STAINLESS STEEL	STAINLESS STEEL	STAINLESS STEEL
2	SHAFT END	STAINLESS STEEL	STAINLESS STEEL	STAINLESS STEEL
3	MECHANICAL SEAL	CERAMIC-CARBON	SIC/SIC	SiC / SiC
4	BEARING RING	GRAPHITE	GRAPHITE	GRAPHITE
5	CABLE	EPDM	EPDM	EPDM
6	STRUCTURAL PARTS	CAST IRON	STAINLESS STEEL	STAINLESS STEEL
7	EXTERNAL SLEEVE	STAINLESS STEEL	STAINLESS STEEL	STAINLESS STEEL
8	THRUST BEARING ROTATING	GRAPHITE	GRAPHITE	Graphite
9	THRUST BEARING STATIONARY	STAINLESS STEEL	STAINLESS STEEL	STAINLESS STEEL
10	DIAPHRAGM	EPDM	EPDM	EPDM
11	BOLTS & SCREWS	STAINLESS STEEL	STAINLESS STEEL	STAINLESS STEEL

### DIMENSION - THREE PHASE MOTORS - 2 poles

TYPE	P2		LENGTH mm	WEIGHT Kg	AXIAL THRUST N
	hp	kW			
50 Hz	30	22	1010	126	60000
	35	26	1050	134	60000
	40	30	1110	146	60000
	50	37	1160	156	60000
	60	45	1270	177	60000
	75	55	1350	192	60000
	85	63	1490	218	60000
	100	75	1590	237	60000
	125	92	1830	283	60000
	150	110	2060	333	60000

### DIMENSION - THREE PHASE MOTORS - 4 poles

TYPE	P2		LENGTH mm	WEIGHT Kg	AXIAL THRUST N
	hp	kW			
50 Hz	15	11	1110	146	60000
	20	15	1160	156	60000
	25	18,5	1270	177	60000
	30	22	1350	192	60000
	35	26	1490	218	60000
	40	30	1590	237	60000
	50	37	1830	283	60000

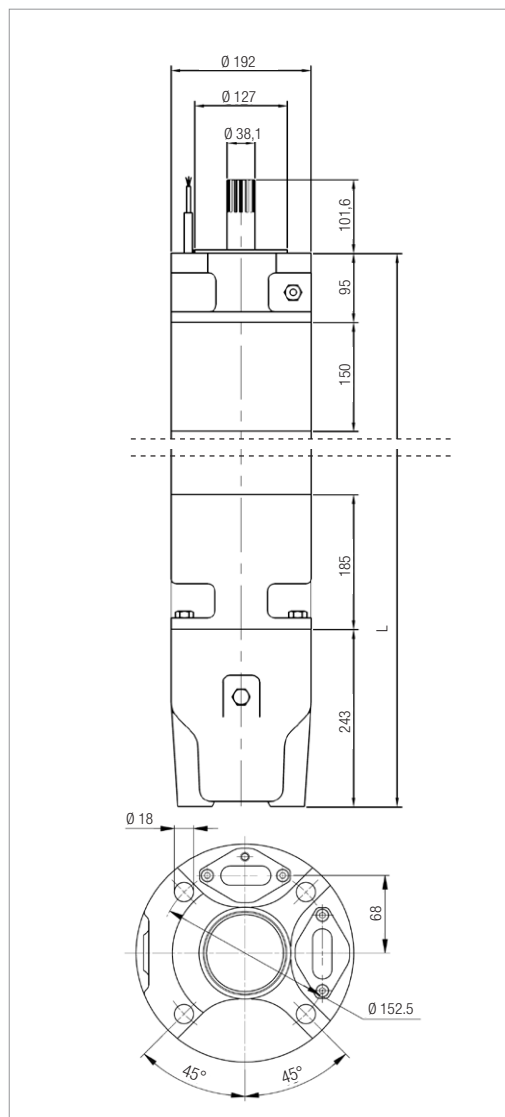

### DERATING

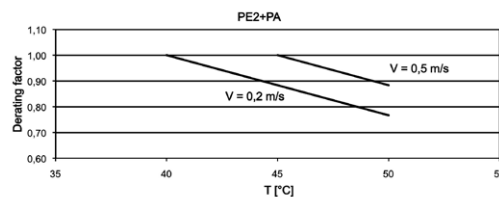
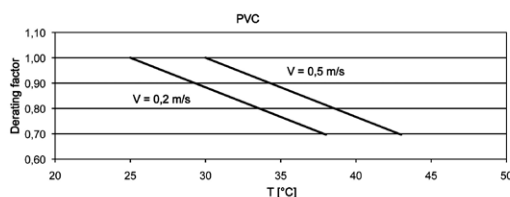

For TR8 110 kW the maximum liquid temperature is 5 °C lower than the values stated in the table above

### ELECTRICAL DATA - THREE PHASE MOTORS - 2 POLES - DOL

MODEL	P2		VOLTAGE 50Hz	In A	Is/In	P1 W	N min <sup>-1</sup>	Cos φ	η %	CABLE	
	hp	kW								Ø mm <sup>2</sup>	LC m
TR8 - 22kW - 400V - T	30	22	400	46	5,3	26829	2890	0,84	82	3x16 + 1 x16	8
TR8 - 26kW - 400V - T	35	26	400	54	5,1	31707	2880	0,85	82	3x16 + 1 x16	8
TR8 - 30kW - 400V - T	40	30	400	61	5,7	35714	2890	0,85	84	3x16 + 1 x16	8
TR8 - 37kW - 400V - T	50	37	400	75	5,7	44048	2890	0,85	84	3x16 + 1 x16	8
TR8 - 45kW - 400V - T	60	45	400	92	6,0	52326	2910	0,82	86	3x16 + 1 x16	8
TR8 - 55kW - 400V - T	75	55	400	109	5,9	63953	2900	0,85	86	3x16 + 1 x16	8
TR8 - 63kW - 400V - T	85	63	400	126	5,7	72414	2910	0,83	87	3x16 + 1 x16	8
TR8 - 75kW - 400V - T	100	75	400	145	5,8	86207	2910	0,86	87	3x16 + 1 x16	8
TR8 - 92kW - 400V - T	125	92	400	177	5,9	105747	2890	0,86	87	3x25 + 1x25	8
TR8 - 110kW - 400V - T	150	110	400	213	5,8	126437	2890	0,87	87	3x25 + 1x25	8

### ELECTRICAL DATA- THREE PHASE MOTORS - 4 POLES - DOL

MODEL	P2		VOLTAGE 50Hz	In A	Is/In	P1 W	N min <sup>-1</sup>	Cos φ	η %	CABLE	
	hp	kW								Ø mm <sup>2</sup>	LC m
TR8 - 11kW - 380V - T	15	11	380	26	5,0	13750	1450	0,79	80	3x6 + 1x6	8
TR8 - 15kW - 380V - T	20	15	380	35	4,9	18519	1450	0,80	81	3x6 + 1x6	8
TR8 - 18,5kW - 380V - T	25	18,5	380	41	4,7	22561	1450	0,83	82	3x6 + 1x6	8
TR8 - 22kW - 380V - T	30	22	380	49	4,7	26829	1450	0,82	82	3x6 + 1x6	8
TR8 - 26kW - 380V - T	35	26	380	58	4,7	32099	1450	0,83	81	3x6 + 1x6	8
TR8 - 30kW - 380V - T	40	30	380	65	4,5	36585	1450	0,85	82	3x6 + 1x6	8
TR8 - 37kW - 380V - T	50	37	380	81	4,5	45122	1450	0,84	82	3x6 + 1x6	8

**P2:** Rated Output  
**V:** Rated Voltage  
**In:** Rated Current  
**Is/In:** Locked rotor current/Rated current  
**P1:** Power Consumption

**N:** Revolution per minute- R.p.m  
**Cos φ:** Power Factor  
**η :** Efficiency  
**Ø:** Cable Section  
**LC:** Cable Length



### TECHNICAL SPECIFICATIONS

**Flange:** 10"  
**Degree of protection:** IP58 (IP68 su richiesta)  
**Cooling flow:** 0.5 m/s  
**Voltage tolerance:** + 6% / -10%  
**Max starts:** 8/h  
**Max operating depth:** 300 m  
**Max operating pressure:** 60 bar  
**Horizontal operation:** 100 HP - 230 HP

### GENERAL DATA

10" Asynchronous two-poles or four-poles submersible motor, rewindable type, with external shell made in AISI 316 stainless steel and supports in cast iron with paint coating (standard version). Cooling and lubrication of the thrust bearing assembly and carbon bushes is provided by a mixture of water and glycol. Squirrel-cage rotor mounted on Mitchell self-centring thrust bearing. The motor is available also in full stainless steel AISI 316 version or AISI 904 version. On request it's available also a version suitable for use with variable frequency drive (30 Hz-50/60 Hz). The motor is equipped with 8 meters single-core cables directly connected with the windings and it's available with DOL or STAR-DELTA starting type. The cables are certified ACS and WRAS and KTW. Overload protection must be provided by user. On request PT100 and PTC temperature sensors are available.

### COMPONENTS



The stator is rewindable type and it's inserted in an AISI 316 stainless steel outer shell (on request AISI 904). In the standard version the windings are made in copper insulated by PVC (230 HP and 260 HP by PE2+PA). On request it's available the PE2+PA windings for special applications such as the use with a variable frequency drive.

Mitchell type thrust bearing unit consisting of tilting pads in graphite and ceramic disc.  
 From 100 HP to 260 HP: 60000 N  
 Uplthrust: 12500 N

shafts made of stainless steel with end part with key coupling. Squirrel-cage rotor made in copper. In the standard version the motor is equipped with a ceramic/carbon mechanical seal. On request it's available the silicon carbide (SiC/SiC) mechanical seal. On request the motor can be equipped also with a lip seal (granting the IP 68 insulation).

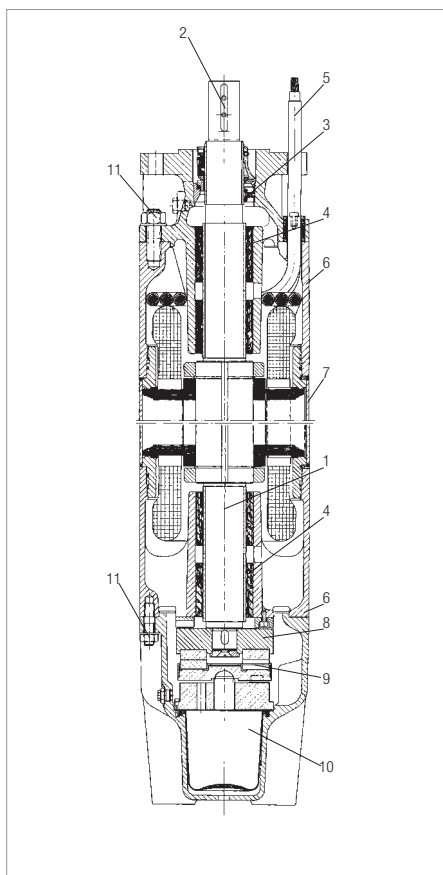

### MATERIALS

N°	COMPONENTS	STD VERSION	316 SS VERSION	904 SS VERSION
1	SHAFT	STAINLESS STEEL	STAINLESS STEEL	STAINLESS STEEL
2	SHAFT END	STAINLESS STEEL AISI 316	STAINLESS STEEL AISI 316	STAINLESS STEEL AISI 904
3	MECHANICAL SEAL	CERAMIC / CARBON	SiC/SiC	SiC / SiC
4	BEARING RING	GRAPHITE	GRAPHITE	GRAPHITE
5	CABLE	EPDM	EPDM	EPDM
6	STRUCTURAL PARTS	CAST IRON	STAINLESS STEEL AISI 316	STAINLESS STEEL AISI 904
7	EXTERNAL SLEEVE	STAINLESS STEEL AISI 316	STAINLESS STEEL AISI 316	STAINLESS STEEL AISI 904
8	THRUST BEARING ROTATING	CERAMIC	CERAMIC	CERAMIC
9	THRUST BEARING STATIONARY	GRAPHITE	GRAPHITE	GRAPHITE
10	DIAPHRAGM	EPDM	EPDM	EPDM
11	BOLTS & SCREWS	STAINLESS STEEL AISI 304	STAINLESS STEEL AISI 316	STAINLESS STEEL AISI 904

### DIMENSION - THREE PHASE MOTORS - 2 poles

TYPE	P2		LENGTH mm	WEIGHT Kg	AXIAL THRUST N
	hp	kW			
50 Hz	100	75	1400	280	60000
	125	92	1500	330	60000
	150	110	1690	385	60000
	180	132	1870	435	60000
	200	147	2070	500	60000
	230	170	2220	540	60000
	260	190	2400	580	60000

### DIMENSION - THREE PHASE MOTORS - 4 poles

TYPE	P2		LENGTH mm	WEIGHT Kg	AXIAL THRUST N
	hp	kW			
50 Hz	40	30	1270	250	60000
	50	37	1400	280	60000
	60	45	1500	330	60000
	75	55	1690	385	60000
	100	75	1870	435	60000
	125	92	2070	500	60000

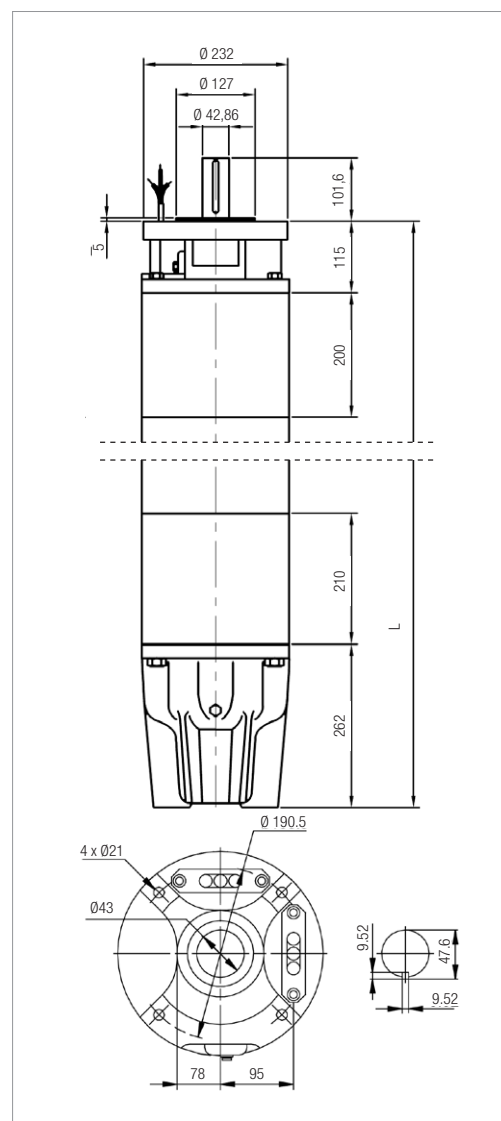

### DERATING

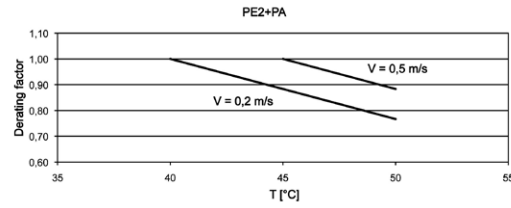
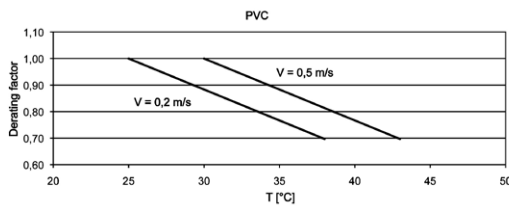

For TR10 170 kW PE2+PA the maximum liquid temperature is 5 °C lower than the values stated in the table above. For TR10 190 kW PE2+PA is 10 °C lower.

### ELECTRICAL DATA - THREE PHASE MOTORS - 2 POLES - DOL

MODEL	P2		VOLTAGE 50Hz	In A	Is/In	P1 W	N min <sup>-1</sup>	Cos φ	η %	CABLE	
	hp	kW								Ø mm <sup>2</sup>	LC m
TR10 - 75kW - 400V - T	100	75	400	148	5,4	86207	2910	0,84	87	3x50+1x25	8
TR10 - 92kW - 400V - T	125	92	400	185	5,6	105747	2910	0,82	87	3x50+1x25	8
TR10 - 110kW - 400V - T	150	110	400	217	5,7	125000	2910	0,84	88	3x50+1x25	8
TR10 - 132kW - 400V - T	180	132	400	257	5,7	150000	2910	0,84	88	3x50+1x25	8
TR10 - 147kW - 400V - T	200	147	400	300	6,2	168966	2920	0,81	87	3x50+1x25	8
TR10 - 170kW - 400V - T	230	170	400	348	6,0	195402	2920	0,81	87	3x50+1x25	8
TR10 - 190kW - 400V - T	260	190	400	405	5,9	218391	2930	0,79	87	3x50+1x25	8

### ELECTRICAL DATA - THREE PHASE MOTORS - 4 POLES - DOL

MODEL	P2		VOLTAGE 50Hz	In A	Is/In	P1 W	N min <sup>-1</sup>	Cos φ	η %	CABLE	
	hp	kW								Ø mm <sup>2</sup>	LC m
TR10 - 30kW - 380V - T	40	30	380	64	5,3	35294	1450	0,83	85	3x50+1x25	8
TR10 - 37kW - 380V - T	50	37	380	75	5,5	43023	1450	0,87	86	3x50+1x25	8
TR10 - 45kW - 380V - T	60	45	380	92	4,6	51724	1450	0,84	87	3x50+1x25	8
TR10 - 55kW - 380V - T	75	55	380	113	5,3	62500	1450	0,85	88	3x50+1x25	8
TR10 - 75kW - 380V - T	100	75	380	153	5,4	86207	1450	0,84	87	3x50+1x25	8
TR10 - 90kW - 380V - T	125	90	380	190	5,3	103448	1450	0,85	87	3x50+1x25	8

P2: Rated Output  
V: Rated Voltage  
In: Rated Current  
Is/In: Locked rotor current/Rated current  
P1: Power Consumption

N: Revolution per minute- R.p.m  
Cos φ: Power Factor  
η: Efficiency  
Ø: Cable Section  
LC: Cable Length



### TECHNICAL SPECIFICATIONS

**Flange:** 12"

**Degree of protection:** IP58 (IP68 su richiesta)

**Cooling flow:** 0.5 m/s

**Voltage tolerance:** + 6% / -10%

**Max starts:** 5/h

**Max operating depth:** 300 m

**Max operating pressure:** 60 bar

**Horizontal operation:** 180 HP - 260 HP

**Senso di rotazione:** da specificare in fase d'ordine, la versione standard è antioraria.

### GENERAL DATA

12" Asynchronous two-poles or four-poles submersible motor, rewindable type, with external shell made in AISI 316 stainless steel and supports in cast iron with paint coating (standard version). Cooling and lubrication of the thrust bearing assembly and carbon bushes is provided by a mixture of water and glycol. Squirrel-cage rotor mounted on Mitchell self-centring thrust bearing. The motor is available also in full stainless steel AISI 316 version and AISI 904 version. On request it's available also a version suitable for use with variable frequency drive (30 Hz-50/60 Hz). The motor is equipped with 8 meters single-core cables directly connected with the windings and it's available with DOL or STAR-DELTA starting type. The cables are certified ACS and WRAS and KTW. Overload protection must be provided by user.

On request PT100 and PTC temperature sensors are available.

### COMPONENTS



The stator is rewindable type and it's inserted in an AISI 316 stainless steel outer shell. In the standard version the windings are made in copper insulated by PVC (PE2+PA on 300 HP and 340 HP). On request it's available the PE2+PA windings for special applications such as the use with a variable frequency drive.

Mitchell type thrust bearing unit consisting of tilting pads in stainless steel covered by rubber and stainless steel disc.

From 200 HP to 340 HP:

70000 N (single direction of rotation)

35000 N (double direction of rotation)

Upthrust: 15000 N

Shafts made of stainless steel with end part with key coupling. Squirrel-cage rotor made in copper. In the standard version the motor is equipped with a ceramic/carbon mechanical seal. On request it's available the silicon carbide (SiC/SiC) mechanical seal. On request the motor can be equipped also with a lip seal (granting the IP 68 insulation).



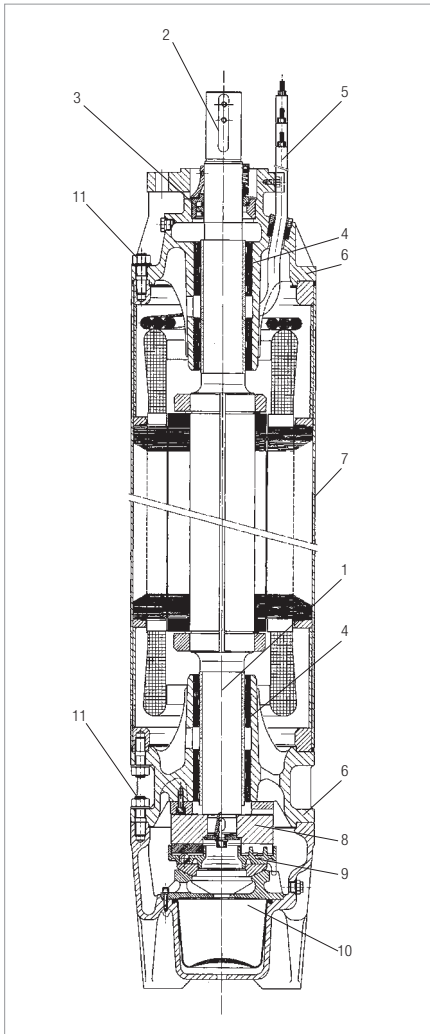

### MATERIALS

N°	COMPONENTS	STD VERSION	316 SS VERSION	904 SS VERSION
1	SHAFT	STAINLESS STEEL	STAINLESS STEEL	STAINLESS STEEL
2	SHAFT END	STAINLESS STEEL	STAINLESS STEEL	STAINLESS STEEL
3	MECHANICAL SEAL	CERAMIC-CARBON	SIC/SIC	SIC / SIC
4	BEARING RING	GRAPHITE	GRAPHITE	GRAPHITE
5	CABLE	EPDM	EPDM	EPDM
6	STRUCTURAL PARTS	CAST IRON	STAINLESS STEEL	STAINLESS STEEL
7	EXTERNAL SLEEVE	STAINLESS STEEL	STAINLESS STEEL	STAINLESS STEEL
8	THRUST BEARING ROTATING	GRAPHITE	GRAPHITE	Graphite
9	THRUST BEARING STATIONARY	STAINLESS STEEL	STAINLESS STEEL	STAINLESS STEEL
10	DIAPHRAGM	EPDM	EPDM	EPDM
11	BOLTS & SCREWS	STAINLESS STEEL	STAINLESS STEEL	STAINLESS STEEL

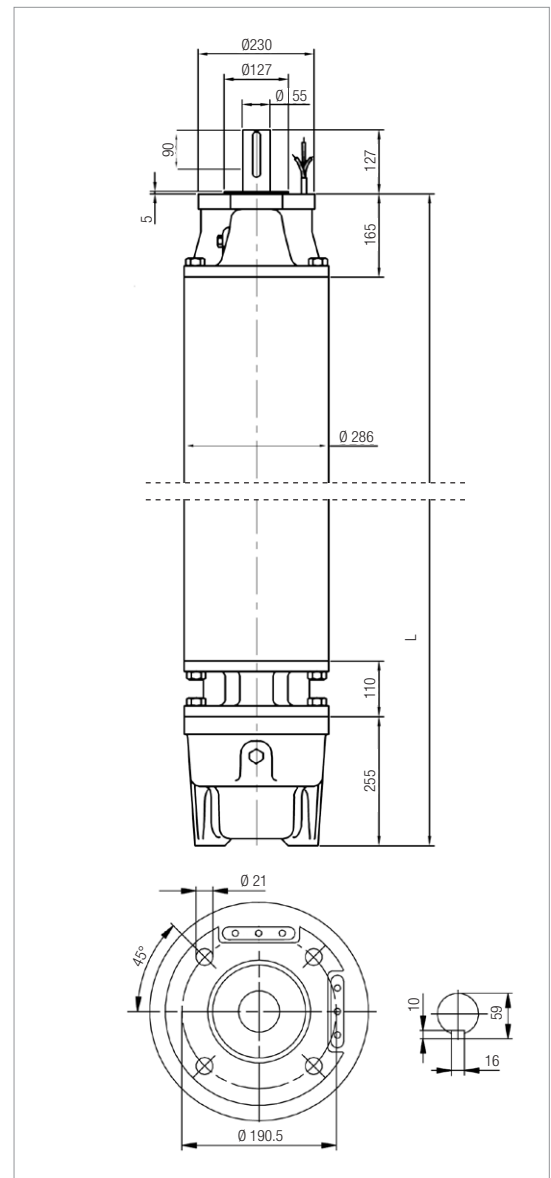

### DIMENSION - THREE PHASE MOTORS - 2 poles

TYPE	P2		LENGTH mm	WEIGHT Kg	AXIAL THRUST N
	hp	kW			
50 Hz	180	132	1700	510	70000
	200	147	1790	565	70000
	230	170	1880	605	70000
	260	190	1980	650	70000
	300	220	2110	700	70000
	340	250	2280	775	70000

### DIMENSION - THREE PHASE MOTORS - 4 poles

TYPE	P2		LENGTH mm	WEIGHT Kg	AXIAL THRUST N
	hp	kW			
50 Hz	100	75	1660	515	70000
	125	92	1790	565	70000
	150	110	1880	605	70000
	180	132	2110	700	70000
	200	147	2210	750	70000

### DERATING

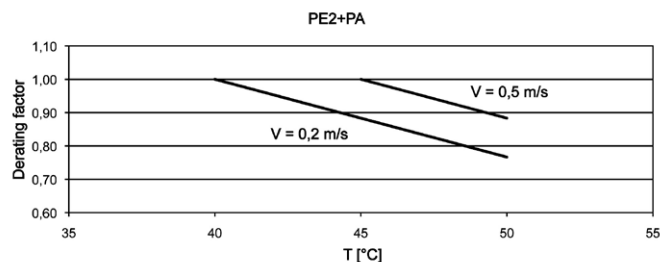
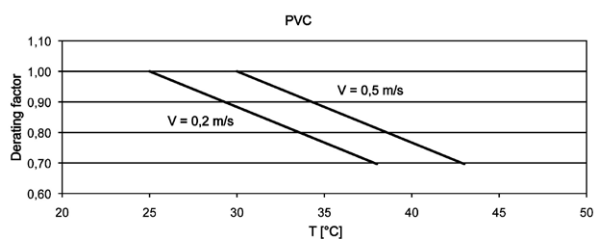

For TR12 220 kW PE2+PA and 250 kW PE2+PA 50 Hz and for all TR 12 60 Hz the maximum liquid temperature is 10 °C lower than the values stated in the table above.

### ELECTRICAL DATA - THREE PHASE MOTORS - 2 POLES - DOL

MODEL	P2		VOLTAGE 50Hz	In A	Is/In	P1 W	N min <sup>-1</sup>	Cos φ	η %	CABLE	
	hp	kW								Ø mm <sup>2</sup>	LC m
TR12 - 132kW - 400V - T	180	132	400	266	5,0	150700	2930	0,82	88	3x70+1x50	8
TR12 - 147kW - 400V - T	200	147	400	290	6,2	167045	2930	0,83	88	3x70+1x50	8
TR12 - 170kW - 400V - T	230	170	400	329	6,1	193182	2920	0,85	88	3x70+1x50	8
TR12 - 190kW - 400V - T	260	190	400	371	6,2	215909	2930	0,84	88	3x70+1x50	8
TR12 - 220kW - 400V - T	300	220	400	424	6,1	250000	2920	0,85	88	3x70+1x50	8
TR10 - 250kW - 400V - T	340	250	400	481	5,9	284091	2920	0,85	88	3x70+1x50	8

### ELECTRICAL DATA - THREE PHASE MOTORS - 4 POLES - DOL

MODEL	P2		VOLTAGE 50Hz	In A	Is/In	P1 W	N min <sup>-1</sup>	Cos φ	η %	CABLE	
	hp	kW								Ø mm <sup>2</sup>	LC m
TR12 - 75kW - 380V - T	100	75	380	147	6,5	85227	1450	0,86	88	3x70+1x50	8
TR12 - 92kW - 380V - T	125	92	380	182	6,5	103371	1450	0,87	89	3x70+1x50	8
TR12 - 110kW - 380V - T	150	110	380	214	5,8	123596	1450	0,88	89	3x70+1x50	8
TR12 - 132kW - 380V - T	180	132	380	256	5,8	148315	1450	0,88	89	3x70+1x50	8
TR12 - 147kW - 380V - T	200	147	380	285	5,9	165169	1450	0,88	89	3x70+1x50	8

**P2:** Rated Output  
**V:** Rated Voltage  
**In:** Rated Current  
**Is/In:** Locked rotor current/Rated current  
**P1:** Power Consumption

**N:** Revolution per minute- R.p.m  
**Cos φ:** Power Factor  
**η:** Efficiency  
**Ø:** Cable Section  
**LC:** Cable Length

# HYDRAULIC EFFICIENCY

---

### GENERAL INFORMATION

With the aim of defining a comparable performance threshold value among all water pumps present on the market, an index has been created which considers the size of the pump, its specific speed and rotation speed: the MEI (Minimum Efficiency Index). The regulation applies to centrifugal pumps for pumping clean water included in these product categories:

- Pumps with axial intake with support (ESOB)
- Pumps with monobloc horizontal axial intake (ESCC)
- Pumps with monobloc in-line axial intake (ESCCI)
- Multistage vertical pumps (MS-V)
- Multistage submerged pumps (MSS)

MEI represents a dimensionless indicator for hydraulic performance and is a measurement of the sizing of the pump with respect to its performance. The higher the MEI value, the better the sizing of the pump with respect to its performance and the lower the yearly energy consumption due to use of the pump. The upper limit of the MEI values is theoretically open, and depends only on physical and technological limits.

**The minimum efficiency index (MEI) is based on the maximum diameter of the impeller. Multistage submerged water pumps must undergo tests in a version with 9 stages.**

The reference value for the most efficient water pumps is  $MEI \geq 0.70$ .

The efficiency of a pump with a trimmed impeller is usually lower than that of a pump with the full impeller diameter. The trimming of the impeller adapts the pump to a fixed work point, with a consequent lower energy consumption.

The operation of this water pump with variable operating points may be more efficient and economic if controlled, for example, by means of a variable speed motor which adapts pump operation to the system.

You can find information on reference efficiency at the address: [www.dabpumps.com](http://www.dabpumps.com) or contact our sales network.

The efficiency graphs for  $MEI=0.7$  and  $MEI=0.4$  for the different types of pumps are available on the site: [www.europump.org/efficiencycharts](http://www.europump.org/efficiencycharts)

PUMP MODEL	N° STAGES	MEI	$\eta_{PL}$	$\eta_{BEP}$	$\eta_{OL}$
SS6A/09	9	$\geq 0,40$	67,01	70,60	69,74
SS6A/08	8		67,01	70,60	69,74
SS6A/10	10		67,01	70,60	69,74
SS6A/11	11		67,01	70,60	69,74
SS6A/12	12		67,01	70,60	69,74
SS6A/13	13		67,01	70,60	69,74
SS6A/14	14		67,01	70,60	69,74
SS6A/15	15		67,01	70,60	69,74
SS6A/16	16		67,01	70,60	69,74
SS6A/17	17		67,01	70,60	69,74
SS6A/18	18		67,01	70,60	69,74
SS6A/19	19		67,01	70,60	69,74
SS6A/20	20		67,01	70,60	69,74
SS6A/21	21		67,01	70,60	69,74
SS6A/22	22		67,01	70,60	69,74
SS6A/23	23		67,01	70,60	69,74
SS6A/24	24	67,01	70,60	69,74	

# HYDRAULIC EFFICIENCY

EU REGULATION 547/2012 – MEI

PUMP MODEL	N° STAGES	MEI	$\eta$ PL	$\eta$ BEP	$\eta$ OL
SS6A/25	25	$\geq 0,40$	67,01	70,60	69,74
SS6A/26	26		67,01	70,60	69,74
SS6A/27	27		67,01	70,60	69,74
SS6A/28	28		67,01	70,60	69,74
SS6A/29	29		67,01	70,60	69,74
SS6A/30	30		67,01	70,60	69,74
SS6A/31	31		67,01	70,60	69,74
SS6A/32	32		67,01	70,60	69,74
SS6A/33	33		67,01	70,60	69,74
SS6A/34	34		67,01	70,60	69,74
SS6A/35	35		67,01	70,60	69,74
SS6A/36	36		67,01	70,60	69,74
SS6A/37	37		67,01	70,60	69,74
SS6A/38	38		67,01	70,60	69,74
SS6A/39	39		67,01	70,60	69,74
SS6A/40	40		67,01	70,60	69,74
SS6A/41	41		67,01	70,60	69,74
SS6A/42	42		67,01	70,60	69,74
SS6A/43	43		67,01	70,60	69,74
SS6A/44	44		67,01	70,60	69,74
SS6A/45	45		67,01	70,60	69,74
SS6A/46	46		67,01	70,60	69,74
SS6A/47	47		67,01	70,60	69,74
SS6A/48	48		67,01	70,60	69,74
SS6A/49	49		67,01	70,60	69,74
SS6A/50	50		67,01	70,60	69,74
SS6A/51	51		67,01	70,60	69,74
SS6A/52	52		67,01	70,60	69,74
SS6A/53	53		67,01	70,60	69,74
SS6A/54	54		67,01	70,60	69,74
SS6A/55	55		67,01	70,60	69,74
SS6A/56	56		67,01	70,60	69,74
SS6A/57	57		67,01	70,60	69,74
SS6A/58	58		67,01	70,60	69,74
SS6A/59	59		67,01	70,60	69,74
SS6A/60	60		67,01	70,60	69,74

HYDRAULIC EFFICIENCY

# HYDRAULIC EFFICIENCY

EU REGULATION 547/2012 – MEI

PUMP MODEL	N° STAGES	MEI	$\eta_{PL}$	$\eta_{BEP}$	$\eta_{OL}$
SS6B/09	9	$\geq 0,40$	70,72	74,52	73,68
SS6B/7	7		70,72	74,52	73,68
SS6B/8	8		70,72	74,52	73,68
SS6B/10	10		70,72	74,52	73,68
SS6B/11	11		70,72	74,52	73,68
SS6B/12	12		70,72	74,52	73,68
SS6B/13	13		70,72	74,52	73,68
SS6B/14	14		70,72	74,52	73,68
SS6B/15	15		70,72	74,52	73,68
SS6B/16	16		70,72	74,52	73,68
SS6B/17	17		70,72	74,52	73,68
SS6B/18	18		70,72	74,52	73,68
SS6B/19	19		70,72	74,52	73,68
SS6B/20	20		70,72	74,52	73,68
SS6B/21	21		70,72	74,52	73,68
SS6B/22	22		70,72	74,52	73,68
SS6B/23	23		70,72	74,52	73,68
SS6B/24	24		70,72	74,52	73,68
SS6B/25	25		70,72	74,52	73,68
SS6B/26	26		70,72	74,52	73,68
SS6B/27	27		70,72	74,52	73,68
SS6B/28	28		70,72	74,52	73,68
SS6B/29	29		70,72	74,52	73,68
SS6B/30	30		70,72	74,52	73,68
SS6B/31	31		70,72	74,52	73,68
SS6B/32	32		70,72	74,52	73,68
SS6B/33	33		70,72	74,52	73,68
SS6B/34	34		70,72	74,52	73,68
SS6B/35	35		70,72	74,52	73,68
SS6B/36	36		70,72	74,52	73,68
SS6B/37	37		70,72	74,52	73,68
SS6B/38	38		70,72	74,52	73,68
SS6B/39	39		70,72	74,52	73,68
SS6B/40	40		70,72	74,52	73,68
SS6B/41	41		70,72	74,52	73,68
SS6B/42	42		70,72	74,52	73,68
SS6B/43	43		70,72	74,52	73,68
SS6B/44	44		70,72	74,52	73,68
SS6B/45	45		70,72	74,52	73,68
SS6B/46	46		70,72	74,52	73,68
SS6B/47	47		70,72	74,52	73,68
SS6B/48	48		70,72	74,52	73,68
SS6B/49	49		70,72	74,52	73,68
SS6B/50	50		70,72	74,52	73,68
SS6B/51	51		70,72	74,52	73,68
SS6B/52	52		70,72	74,52	73,68
SS6B/53	53		70,72	74,52	73,68
SS6B/54	54		70,72	74,52	73,68
SS6B/55	55		70,72	74,52	73,68
SS6B/56	56		70,72	74,52	73,68
SS6B/57	57		70,72	74,52	73,68
SS6B/58	58		70,72	74,52	73,68
SS6B/59	59		70,72	74,52	73,68
SS6B/60	60		70,72	74,52	73,68

# HYDRAULIC EFFICIENCY

EU REGULATION 547/2012 – MEI

PUMP MODEL	N° STAGES	MEI	$\eta$ PL	$\eta$ BEP	$\eta$ OL
SS6C/9	9	$\geq 0,40$	72,03	76,10	75,41
SS6C/4	4		71,03	75,10	74,41
SS6C/5	5		72,03	76,10	75,41
SS6C/6	6		72,03	76,10	75,41
SS6C/7	7		72,03	76,10	75,41
SS6C/8	8		72,03	76,10	75,41
SS6C/10	10		72,03	76,10	75,41
SS6C/11	11		72,03	76,10	75,41
SS6C/12	12		72,03	76,10	75,41
SS6C/13	13		72,03	76,10	75,41
SS6C/14	14		72,03	76,10	75,41
SS6C/15	15		72,03	76,10	75,41
SS6C/16	16		72,03	76,10	75,41
SS6C/17	17		72,03	76,10	75,41
SS6C/18	18		72,03	76,10	75,41
SS6C/19	19		72,03	76,10	75,41
SS6C/20	20		72,03	76,10	75,41
SS6C/21	21		72,03	76,10	75,41
SS6C/22	22		72,03	76,10	75,41
SS6C/23	23		72,03	76,10	75,41
SS6C/24	24		72,03	76,10	75,41
SS6C/25	25		72,03	76,10	75,41
SS6C/26	26		72,03	76,10	75,41
SS6C/27	27		72,03	76,10	75,41
SS6C/28	28		72,03	76,10	75,41
SS6C/29	29		72,03	76,10	75,41
SS6C/30	30		72,03	76,10	75,41
SS6C/31	31		72,03	76,10	75,41
SS6C/32	32		72,03	76,10	75,41
SS6C/33	33		72,03	76,10	75,41
SS6C/34	34		72,03	76,10	75,41
SS6C/35	35		72,03	76,10	75,41
SS6C/36	36		72,03	76,10	75,41
SS6C/37	37		72,03	76,10	75,41
SS6C/38	38		72,03	76,10	75,41
SS6C/39	39		72,03	76,10	75,41
SS6C/40	40		72,03	76,10	75,41
SS6C/41	41		72,03	76,10	75,41
SS6C/42	42		72,03	76,10	75,41
SS6C/43	43		72,03	76,10	75,41
SS6C/44	44		72,03	76,10	75,41
SS6C/45	45		72,03	76,10	75,41
SS6C/46	46		72,03	76,10	75,41
SS6C/47	47		72,03	76,10	75,41
SS6C/48	48		72,03	76,10	75,41
SS6C/49	49		72,03	76,10	75,41
SS6C/50	50		72,03	76,10	75,41
SS6C/51	51		72,03	76,10	75,41
SS6C/52	52		72,03	76,10	75,41
SS6C/53	53		72,03	76,10	75,41
SS6C/54	54		72,03	76,10	75,41

HYDRAULIC EFFICIENCY

# HYDRAULIC EFFICIENCY

EU REGULATION 547/2012 – MEI

PUMP MODEL	N° STAGES	MEI	$\eta_{PL}$	$\eta_{BEP}$	$\eta_{OL}$
SS6D/9	9	$\geq 0,40$	72,67	76,30	75,42
SS6D/3	3		70,67	74,30	73,42
SS6D/4	4		71,67	75,30	74,42
SS6D/5	5		72,67	76,30	75,42
SS6D/6	6		72,67	76,30	75,42
SS6D/7	7		72,67	76,30	75,42
SS6D/8	8		72,67	76,30	75,42
SS6D/10	10		72,67	76,30	75,42
SS6D/11	11		72,67	76,30	75,42
SS6D/12	12		72,67	76,30	75,42
SS6D/13	13		72,67	76,30	75,42
SS6D/14	14		72,67	76,30	75,42
SS6D/15	15		72,67	76,30	75,42
SS6D/16	16		72,67	76,30	75,42
SS6D/17	17		72,67	76,30	75,42
SS6D/18	18		72,67	76,30	75,42
SS6D/19	19		72,67	76,30	75,42
SS6D/20	20		72,67	76,30	75,42
SS6D/21	21		72,67	76,30	75,42
SS6D/22	22		72,67	76,30	75,42
SS6D/23	23		72,67	76,30	75,42
SS6D/24	24		72,67	76,30	75,42
SS6D/25	25		72,67	76,30	75,42
SS6D/26	26		72,67	76,30	75,42
SS6D/27	27		72,67	76,30	75,42
SS6D/28	28		72,67	76,30	75,42
SS6D/29	29		72,67	76,30	75,42
SS6D/30	30		72,67	76,30	75,42
SS6D/31	31		72,67	76,30	75,42
SS6D/32	32		72,67	76,30	75,42
SS6D/33	33		72,67	76,30	75,42



# HYDRAULIC EFFICIENCY

EU REGULATION 547/2012 – MEI

PUMP MODEL	N° STAGES	MEI	$\eta$ PL	$\eta$ BEP	$\eta$ OL
SS6E/9	9	$\geq 0,40$	72,40	77,30	75,51
SS6E/2	2		69,40	74,30	72,51
SS6E/3	3		70,40	75,30	73,51
SS6E/4	4		71,40	76,30	74,51
SS6E/5	5		72,40	77,30	75,51
SS6E/6	6		72,40	77,30	75,51
SS6E/7	7		72,40	77,30	75,51
SS6E/8	8		72,40	77,30	75,51
SS6E/10	10		72,40	77,30	75,51
SS6E/11	11		72,40	77,30	75,51
SS6E/12	12		72,40	77,30	75,51
SS6E/13	13		72,40	77,30	75,51
SS6E/14	14		72,40	77,30	75,51
SS6E/15	15		72,40	77,30	75,51
SS6E/16	16		72,40	77,30	75,51
SS6E/17	17		72,40	77,30	75,51
SS6E/18	18		72,40	77,30	75,51
SS6E/19	19		72,40	77,30	75,51
SS6E/20	20		72,40	77,30	75,51
SS6E/21	21		72,40	77,30	75,51
SS6E/22	22		72,40	77,30	75,51
SS6E/23	23		72,40	77,30	75,51
SS6E/24	24		72,40	77,30	75,51
SS6E/25	25		72,40	77,30	75,51
SS6E/26	26		72,40	77,30	75,51
SS6E/27	27		72,40	77,30	75,51
SS6E/28	28		72,40	77,30	75,51
SS6E/29	29		72,40	77,30	75,51
SS6E/30	30		72,40	77,30	75,51



# CONTROL PANELS

---

### ESC PLUS

Panel for protection and control of motor/single-phase/three-phase pump with direct start up.

Double set-up mode: automatic/manual

The motor/pump protection against dry running is assured by the major of the motor cos j, (level probes not required)

Casing made of shock-proof and self-extinguishing thermoplastic material with two antipull plugs.

Main switch.

Power supply: Single-phase 230 V +/- 5%, Three-phase 400 V +/-5%.

Digital display with status indications.

Four models available for powers from 0.5 HP to 15 HP.

Protection degree IP54. Starting

Capacitor for single phase version (to be order separately).

Optoisolated auxiliary contact for control by probes, pressure switch and float switch.

ON-OFF switch.

Functional features:

Overload protection.

Phase failure protection (threephase version).

Overvoltage protection.

Short circuit protection.

Protection against dry running.

	MODEL	VOLTAGE 50-60 Hz	RANGE HP	MAX CURRENT A	PANEL DIMENSIONS			WEIGHT Kg
					A	B	H	
	ESC PLUS 3M 220-240/50-60	1 x 230 V,	0,5 - 3	< 18	175	175	80	0,9
	ESC PLUS 4T 400/50-60	3 x 400 V,	0,5 - 4	< 9	245	195	95	1
	ESC PLUS 10T 400/50-60	3 x 400 V,	5,5 - 10	< 20	215	170	75	1,4
	ESC PLUS 15T 400/50-60	3 x 400 V,	12,5 - 15	< 30	215	170	75	1,6

### COMMANDER - SOFT-START CONTROL AND PROTECTION

Soft-start control microprocessor for protection, control and command of the motor / three-phase pump with direct starting. The soft-start Commander panel is used where a limitation of the starting current is required; in this case, the traditional starting systems (star-delta system or reactance) are no longer required. There are also several parameters that can be set for both the start-up and shutdown of the system. Characteristics: input voltage: 400 Vac +/-10%. power frequency: 50/60 Hz ambient temperature: 0-40° c. relative humidity: 50% at 40° c. IP55 Protection. Metal frame with epoxy paint.

Bypass contactor of the SCRs. Input signal from the pressure switch or float. Possibility to connect several motors /pumps. Measurement of power factor (cos). Programming of the following functions from external LCD keypad: programming in 6 languages, set up menu and displays the following parameters: voltage, current, active and apparent power, power factor, the list of events / actions.

Features: Overload protection, protection and control of the starting current, phase failure protection, surge protection under voltage protection and short-circuit protection.

	MODEL	VOLTAGE 50-60 Hz	RANGE	MAX CURRENT	PANEL DIMENSIONS	WEIGHT Kg
COMMANDER 2E	400V	35 HP - 60 HP	< 100	300x300x160	9,4	

# CONTROL PANELS

## SUBMERSIBLE PUMPS AND MOTORS

### ES 0,75 T - 1 T - 1,5 T - 3 T - 4 T - 7,5 T

Electric control unit for protecting three-phase electric borehole pumps from running without water (see table). The panel is protected and protects the electric pump from overloading and short circuits with a manually resettable device.

Can work with 1, 2 or 3 probes depending on the use to which it is put.

Protection level: IP55. Temperature application range: from -10°C to +40°C.

Supplied standard with an electric probe and wall bracket.

Cabinet for wall mounting in flame-proof, thermoplastic material.

	MODEL	VOLTAGE 50 HZ	POWER kW p2 MOT.	MAX RATED OPERATING POWER (kW)	MAX CURRENT A	PANEL DIMENSIONS			WEIGHT Kg
						A	B	H	
	ES 0,75 T	3 x 400V	0,37-0,55	0,88	1,6	270	300	190	5,6
	ES 1 T	3 x 400V	0,75	1,38	2,5	270	300	190	5,6
	ES 1,5 T	3 x 400V	1,1	2,2	4	270	300	190	5,6
	ES 3 T	3 x 400V	1,5 - 2,2	3,5	6,3	270	300	190	5,6
	ES 4 T	3 x 400V	3	5,5	10	270	300	190	5,6
	ES 7,5 T	3 x 400V	4-5,5	7,5	14	270	300	190	5,6

### COMMAND AND CONTROL SYSTEM - ES

Electrical panels for protection and automatic control using float/s for bore-hole three phase electric pumps, installed singularly. Available for direct and star-delta starting. Cabinet for wall mounting in flame-proof, thermoplastic material. The panel is self-protected and protects the electric pump from overloading and short circuits, power failure with a manually resettable device.

Supplied complete with:

- power line switch with pad lockable door handle;
- self-protected transformer for 24V powering of external commands;
- terminals for connecting electric pump/s and min. and max. control float/s;

- Probes module for the running without water control;
- terminals for connecting a remote acoustic or luminous alarm (without potential);
- switch on the front of the panel for man - 0 - out operation of the electric pump
- Operating temperature range: -10°C +40°C
- Level of protection: IP55
- The panels are built to EN 60204-1 and EN 60439-1
- Supplied with standard electric probe.

	MODEL	VOLTAGE 50-60 Hz	P2 NOMINAL kW	MAX CURRENT	WEIGHT Kg
	ES 7,5 T	3 x 400V	4 - 5,5	14	5,6
	ES 10 T	3 x 400V	7,5	18	5,6
	ES 12,5 T	3 x 400V	9,2	25	5,9
	ES 15 T	3 x 400V	11	25	8
	ES 20 T	3 x 400V	15	32	8,1
	ES 25 T	3 x 400V	18,5	40	8,3
	ES 30 T	3 x 400V	22	63	8,5
	ES 40 T	3 x 400V	30	80	8,2
	ES 50 T	3 x 400V	37	90	9
	ES 60 T	3 x 400V	45	100	9
	ES 10 T S/D	3 x 400V	7,5	18	5,6
	ES 12,5 T S/D	3 x 400V	9,2	25	5,9
	ES 15 T S/D	3 x 400V	11	25	8
	ES 20 T S/D	3 x 400V	15	32	8,1
	ES 25 T S/D	3 x 400V	18,5	40	8,3
	ES 30 T S/D	3 x 400V	22	63	8,5
	ES 40 T S/D	3 x 400V	30	80	8,2
	ES 50 T S/D	3 x 400V	37	90	9
	ES 60 T S/D	3 x 400V	45	100	9

# CONTROL PANELS

## SUBMERSIBLE PUMPS AND MOTORS

### ADAC - INVERTER

**ADAC** is the leading edge of the Dab Inverters family.

Are ideal for **HEAVY DUTY APPLICATIONS**

They can drive pumps of up to 15 kW. These units combine the simplicity with the robust design and power of an inverter drive. They can be installed in a control panel and must be supplied with external pressure.

The use of a flow sensor (OPTIONAL), allows a better pressure regulation.

The **ADAC** can easily be set up in booster sets, thanks to a standard wire cable connection.

Comfort, energy saving, protections and simplicity are the keywords of this professional series.

The ADAC units are air cooled. These extremely robust panel-mounting inverters feature a metal body and are suitable for heavy-duty applications. ADAC ensure the utmost practicality and increase the average working life of the system, permitting also significant savings in power consumption.



MODEL	NOMINAL MOTOR POWER KW	MAX NOMINAL MOTOR CURRENT A	MIN NOMINAL MOTOR CURRENT A	VOLTAGE 50 Hz	PUMP VOLTAGE 50 - 200 Hz
AD M/T 1.0 AC	1,0	6,5	1	1x230	3x230
AD M/T 1.5 AC	1,5	9,0	1	1x230	3x230
AD M/T 2.2 AC	2,2	11,5	1	1x230	3x230
AD T/T 3.0 AC	3,0	9,0	2	3x400	3x400
AD T/T 4.0 AC	4,0	11	2	3x400	3x400
AD T/T 5.5 AC	5,5	15	2	3x400	3x400
AD T/T 7.5 AC	7,5	22	2	3x400	3x400
AD T/T 11.0 AC	11	31	2	3x400	3x400
AD T/T 15.0 AC	15	41	2	3x400	3x400

# TECHNICAL APPENDIX

---

# TECHNICAL APPENDIX

## SUBMERSIBLE PUMPS AND MOTORS

### THREEPHASE 6" CANNED MOTORS (6GF)

CABLE SIZING ACCORDING WITH 3% VOLTAGE DROP - DIRECT STARTING

MOTOR TYPE	NOMINAL POWER		VOLTAGE V	MOTOR NOMINAL CURRENT In (A)	Cos φ	cable section: 4x ...mm <sup>2</sup>								
						mm <sup>2</sup>	4	6	10	16	25	35	50	70
	kW	HP				A max	41	53	74	99	131	162	202	250
						Max lenght (m)								
6"	4	5,5	3x230	18,3	0,75	46	69	113	178	272	371	511		
6"	5,5	7,5	3x230	24,3	0,75	35	52	85	134	205	279	385	514	
6"	7,5	10	3x230	31	0,78	26	39	64	102	155	212	293	393	
6"	9,3	12,5	3x230	37,3	0,8	21	32	52	82	126	173	239	322	
6"	11	15	3x230	44,2	0,82	-	26	43	68	104	143	198	267	
6"	15	20	3x230	56	0,8	-	-	35	55	84	115	159	214	
6"	18,5	25	3x230	71	0,8	-	-	27	43	66	91	126	169	
6"	22	30	3x230	81,4	0,84	-	-	-	36	56	76	106	143	
6"	4	5,5	3x400	10,6	0,75	138	206	340	535					
6"	5,5	7,5	3x400	14	0,75	105	156	257	405					
6"	7,5	10	3x400	18	0,78	78	117	193	304	465				
6"	9,3	12,5	3x400	22	0,8	62	93	154	243	372	510			
6"	11	15	3x400	25,5	0,82	53	79	130	205	315	432	598		
6"	15	20	3x400	33,4	0,8	41	61	101	160	245	336	465		
6"	18,5	25	3x400	41	0,8	34	50	83	130	200	274	379	509	
6"	22	30	3x400	47	0,84	-	42	69	109	167	230	319	431	
6"	30	40	3x400	61,5	0,85	-	-	52	82	127	174	242	327	
6"	37	50	3x400	79,3	0,8	-	-	-	67	103	141	196	263	

### THREEPHASE 6" CANNED MOTORS (6GF)

CABLE SIZING ACCORDING WITH 3% VOLTAGE DROP - STAR/DELTA STARTING

MOTOR TYPE	NOMINAL POWER		VOLTAGE V	MOTOR NOMINAL CURRENT In (A)	Cos φ	cable section: 4x ...mm <sup>2</sup>								
						mm <sup>2</sup>	4	6	10	16	25	35	50	70
	kW	HP				A max	41	53	74	99	131	162	202	250
						Max lenght (m)								
6"	4	5,5	3x230	18,3	0,75	80	119	196	308	470				
6"	5,5	7,5	3x230	24,3	0,75	60	89	147	232	354	483			
6"	7,5	10	3x230	31	0,78	45	67	111	176	269	367	507		
6"	9,3	12,5	3x230	37,3	0,8	37	55	90	143	218	299	414	556	
6"	11	15	3x230	44,2	0,82	-	45	75	118	181	248	343	463	
6"	15	20	3x230	56	0,8	-	-	60	95	146	199	276	371	
6"	18,5	25	3x230	71	0,8	-	-	47	75	115	157	218	292	
6"	22	30	3x230	81,4	0,84	-	-	-	63	96	132	183	248	
6"	4	5,5	3x400	10,6	0,75	239	356	588						
6"	5,5	7,5	3x400	14	0,75	181	270	445						
6"	7,5	10	3x400	18	0,78	135	202	334	526					
6"	9,3	12,5	3x400	22	0,8	108	161	266	421					
6"	11	15	3x400	25,5	0,82	91	136	225	355	544				
6"	15	20	3x400	33,4	0,8	71	106	176	277	424	581			
6"	18,5	25	3x400	41	0,8	58	87	143	226	346	473			
6"	22	30	3x400	47	0,84	-	72	119	188	289	397	552		
6"	30	40	3x400	61,5	0,85	-	-	90	143	219	301	419	566	
6"	37	50	3x400	79,3	0,8	-	-	-	117	179	245	339	455	



# TECHNICAL APPENDIX

## SUBMERSIBLE PUMPS AND MOTORS

### THREEPHASE 6“-10“ REWINDABLE MOTORS (TR6-TR10)

CABLE SIZING ACCORDING WITH 3% VOLTAGE DROP - DIRECT STARTING

MOTOR TYPE	NOMINAL POWER		VOLTAGE V	MOTOR NOMINAL CURRENT In (A)	Cos φ	cable section: 1x ...mm <sup>2</sup>															
						mm <sup>2</sup>	4	6	10	16	25	35	50	70	95	120	150	185	240	300	
	A max	41				53	74	99	131	162	202	250	301	352	404	461	547	633	Max lenght (m)		
6"	5,5	7,5	3x400	13	0,81	-	156	258	407	624	855										
6"	7,5	10	3x400	18	0,8	-	114	188	297	455	623	862									
6"	9,3	12,5	3x400	21	0,81	-	97	160	252	386	529	733	986								
6"	11	15	3x400	25	0,82	-	80	132	209	321	440	610	822								
6"	13	17,5	3x400	29	0,82	-	69	114	180	277	379	526	709	918							
6"	15	20	3x400	32	0,83	-	62	102	162	248	341	473	638	828							
6"	18,5	25	3x400	39	0,83	-	51	84	133	204	279	388	523	679	822	978					
6"	22	30	3x400	49	0,79	-	42	70	110	169	231	320	429	554	666	789	916				
6"	26	35	3x400	58	0,79	-	-	59	93	143	195	270	362	468	563	666	774	919			
6"	30	40	3x400	65	0,81	-	-	52	81	125	171	237	319	412	498	590	688	820	942		
6"	37	50	3x400	80	0,81	-	-	-	66	101	139	192	259	335	404	480	559	666	766		
8"	45	60	3x400	92	0,82	-	-	-	57	87	120	166	223	290	350	416	485	580	667		
8"	55	75	3x400	109	0,85	-	-	-	-	71	98	137	185	240	292	348	408	491	569		
8"	63	85	3x400	126	0,83	-	-	-	-	63	87	120	162	210	254	303	354	424	489		
8"	75	100	3x400	145	0,86	-	-	-	-	-	73	102	138	180	218	261	307	370	429		
8"	92	125	3x400	177	0,86	-	-	-	-	-	-	83	113	147	179	214	251	303	352		
8"	110	150	3x400	213	0,87	-	-	-	-	-	-	-	93	122	148	178	209	252	293		
10"	132	180	3x400	257	0,84	-	-	-	-	-	-	-	-	102	124	148	173	208	240		
10"	147	200	3x400	300	0,81	-	-	-	-	-	-	-	-	89	108	128	149	178	204		
10"	170	230	3x400	348	0,81	-	-	-	-	-	-	-	-	-	93	110	128	153	176		
10"	190	260	3x400	405	0,79	-	-	-	-	-	-	-	-	-	-	-	111	132	151		

# TECHNICAL APPENDIX

## SUBMERSIBLE PUMPS AND MOTORS

### THREEPHASE 6"-10" REWINDABLE MOTORS (TR6-TR10)

CABLE SIZING ACCORDING WITH 3% VOLTAGE DROP - STAR/DELTA STARTING

MOTOR TYPE	NOMINAL POWER		VOLTAGE V	MOTOR NOMINAL CURRENT In (A)	Cos $\varphi$	cable section: 1x ...mm <sup>2</sup>																						
						mm <sup>2</sup>	4	6	10	16	25	35	50	70	95	120	150	185	240	300								
	A max	41				53	74	99	131	162	202	250	301	352	404	461	547	633										
						Max lenght (m)																						
6"	5,5	7,5	3x400	13	0,81	-	270	446	704																			
6"	7,5	10	3x400	18	0,8	-	197	326	514	787																		
6"	9,3	12,5	3x400	21	0,81	-	167	276	436	668	915																	
6"	11	15	3x400	25	0,82	-	139	229	362	555	761																	
6"	13	17,5	3x400	29	0,82	-	120	198	312	479	656	910																
6"	15	20	3x400	32	0,83	-	107	177	280	429	589	818																
6"	18,5	25	3x400	39	0,83	-	88	145	230	352	484	671	905															
6"	22	30	3x400	49	0,79	-	73	121	191	292	400	553	742	958														
6"	26	35	3x400	58	0,79	-	-	102	161	247	338	467	627	809	974													
6"	30	40	3x400	65	0,81	-	-	89	141	216	296	410	551	713	861													
6"	37	50	3x400	80	0,81	-	-	-	114	175	240	333	448	579	699	830	966											
8"	45	60	3x400	92	0,82	-	-	-	98	151	207	287	386	501	605	719	839											
8"	55	75	3x400	109	0,85	-	-	-	-	124	170	236	319	416	505	602	706	849	984									
8"	63	85	3x400	126	0,83	-	-	-	-	109	150	208	280	364	440	524	612	733	845									
8"	75	100	3x400	145	0,86	-	-	-	-	-	127	176	239	311	378	452	530	640	742									
8"	92	125	3x400	177	0,86	-	-	-	-	-	-	144	195	255	310	370	435	524	608									
8"	110	150	3x400	213	0,87	-	-	-	-	-	-	-	161	211	256	307	361	436	508									
10"	132	180	3x400	257	0,84	-	-	-	-	-	-	-	-	177	215	256	300	360	416									
10"	147	200	3x400	300	0,81	-	-	-	-	-	-	-	-	-	155	186	221	258	307	353								
10"	170	230	3x400	348	0,81	-	-	-	-	-	-	-	-	-	-	161	191	222	265	305								
10"	190	260	3x400	405	0,79	-	-	-	-	-	-	-	-	-	-	-	-	192	228	261								



# DNA<sup>®</sup>

PUMPS SELECTOR



## On-line selection tool



**DAB PUMPS LTD.**

Unit 4 and 5, Stortford Hall Industrial Park,  
Dunmow Road,  
Bishops Stortford,  
Herts  
CM23 5GZ - UK  
salesuk@dwtgroup.com  
Tel. +44 1279 652 776  
Fax +44 1279 657 727



**DAB PUMPS IBERICA S.L.**

Avenida de Castilla nr.1 Local 14  
28830 - San Fernando De Henares - Madrid  
Spain  
info.spain@dwtgroup.com  
Tel. +34 91 6569545  
Fax: +34 91 6569676



**DAB PUMPS INC.**

3226 Benchmark Drive  
Ladson, SC 29456 - USA  
info.usa@dwtgroup.com  
Tel. 1-843-824-6332  
Toll Free 1-866-896-4DAB (4322)  
Fax 1-843-797-3366



**DAB PUMPS B.V.**

Brusselstraat 150  
B-1702 Groot-Bijgaarden - Belgium  
info.belgium@dwtgroup.com  
Tel. +32 2 4668353  
Fax +32 2 4669218



**DAB PRODUCTION HUNGARY KFT.**

H-8800  
Nagykanizsa, Buda Ernó u.5  
Hungary  
Tel. +36 93501700



**DWT SOUTH AFRICA**

Podium at Menlyn,  
3rd Floor, Unit 3001b, 43 Ingersol Road,  
C/O Lois and Atterbury street,  
Menlyn, Pretoria, 0181 - South-Africa  
info.sa@dwtgroup.com  
Tel. +27 12 361 3997  
Fax +27 12 361 3137



**DAB PUMPS POLAND Sp. z o.o.**

Mokotow Marynarska  
ul. Postępu 15C  
02-676 Warszawa - Poland  
Tel. +48 223 81 6085



**DAB PUMPS CHINA**

No.40 Kaituo Road, Qingdao Economic & Technological  
Development Zone  
Qingdao City, Shandong Province - China  
PC: 266500  
info.china@dwtgroup.com  
Tel. +8653286812030-6270  
Fax +8653286812210



**DAB PUMPS B.V.**

Albert Einsteinweg, 4  
5151 DL Drunen - Nederland  
info.netherlands@dwtgroup.com  
Tel. +31 416 387280  
Fax +31 416 387299



**DAB UKRAINE Representative Office**

Regus Horizon Park  
4 M. Hrinchenka St, suit 147  
03680 Kiev - Ukraine  
Tel. +38 044 391 59 43



**DAB PUMPEN DEUTSCHLAND GmbH**

Tackweg 11  
D - 47918 Tönisvorst - Germany  
info.germany@dwtgroup.com  
Tel. +49 2151 82136-0  
Fax +49 2151 82136-36



**OOO DWT GROUP**

Novgorodskaya str, 1, bld G, office 308  
127576 Moscow - Russia  
info.russia@dwtgroup.com  
Tel. +7 495 122 00 35  
Fax +7 495 122 00 36



**DAB PUMPS DE MÉXICO, S.A. DE C.V.**

Av Gral Álvaro Obregón 270, oficina 355  
Hipódromo, Cuauhtémoc 06100  
México, D.F.  
Tel. +52 55 6719 0493